

COMMONWEALTH OF MASSACHUSETTS



---

CONTRACT DOCUMENTS  
AND SPECIAL PROVISIONS

---

PROPOSAL NO.	613740-128923
P.V. =	\$1,816,000.00
PLANS	NO

FOR

**Scheduled and Emergency Structural Repairs at Various Locations**

**in**

**DISTRICT 2**

In accordance with the STANDARD SPECIFICATIONS  
for HIGHWAYS and BRIDGES dated 2024

This Proposal to be opened and read:

**TUESDAY, JANUARY 14, 2025 at 2:00 P.M.**

THIS PAGE IS INTENTIONALLY LEFT BLANK

DOCUMENT 00010

TABLE OF CONTENTS

DOCUMENT 00010  
TABLE OF CONTENTS ..... 00010-1 through 2

DOCUMENT 00102  
NOTICE TO CONTRACTORS ..... 00102- 1 through 2

DOCUMENT 00210  
REQUIREMENTS OF MASSACHUSETTS GENERAL  
LAWS CHAPTER 30 SECTION 39R; CHAPTER 30, SECTION 39O ..... 00210-1 through 4

DOCUMENT 00331  
LOCUS MAP ..... 00331-1 through 2

DOCUMENT 00439  
CONTRACTOR PROJECT EVALUATION FORM ..... 00439-1 through 2

DOCUMENT 00440  
SUBCONTRACTOR PROJECT EVALUATION FORM ..... 00440-1 through 2

DOCUMENT 00710  
GENERAL CONTRACT PROVISIONS..... 00710-1 through 2

DOCUMENT 00715  
SUPPLEMENTAL SPECIFICATIONS ..... 00715-1 through 24

DOCUMENT 00718  
SPECIAL PROVISION FOR PARTICIPATION BY MINORITY OR WOMEN'S  
BUSINESS ENTERPRISES AND SERVICE- DISABLED VETERAN- OWNED  
BUSINESS ENTERPRISES ..... 00718-1 through 10

DOCUMENT 00761  
SPECIAL PROVISIONS FOR CERTIFICATION REGARDING DEBARMENT,  
SUSPENSION, INELIGIBILITY AND VOLUNTARY EXCLUSION ..... 00761-1 through 4

DOCUMENT 00811  
MONTHLY PRICE ADJUSTMENT FOR HOT MIX ASPHALT  
(HMA) MIXTURES..... 00811-1 through 2

DOCUMENT 00812  
MONTHLY PRICE ADJUSTMENT FOR DIESEL FUEL AND GASOLINE ..... 00812-1 through 2

DOCUMENT 00813  
PRICE ADJUSTMENT FOR STRUCTURAL STEEL  
AND REINFORCING STEEL ..... 00813-1 through 4

DOCUMENT 00814  
PRICE ADJUSTMENT FOR PORTLAND CEMENT CONCRETE MIXES ..... 00814-1 through 2

DOCUMENT 00820  
THE COMMONWEALTH OF MASSACHUSETTS  
SUPPLEMENTAL EQUAL EMPLOYMENT OPPORTUNITY,  
NON-DISCRIMINATION AND AFFIRMATIVE ACTION PROGRAM ..... 00820-1 through 6

DOCUMENT 00821  
ELECTRONIC REPORTING REQUIREMENTS  
CIVIL RIGHTS PROGRAM AND CERTIFIED PAYROLL ..... 00821-1 through 2

DOCUMENT 00859  
CONTRACTOR/SUBCONTRACTOR CERTIFICATION FORM ..... 00859-1 through 2

TABLE OF CONTENTS (Continued)

DOCUMENT 00860  
COMMONWEALTH OF MASSACHUSETTS PUBLIC EMPLOYMENT LAWS ..... 00860-1 through 2

DOCUMENT 00861  
STATE PREVAILING WAGE RATES ..... 00861-1 through 42

DOCUMENT A00801  
SPECIAL PROVISIONS ..... A00801-1 through 90

DOCUMENT A00804  
DAILY FORCE ACCOUNT REPORT ..... A00804-1 through 4

DOCUMENT A00815  
WORK ZONE SAFETY  
TEMPORARY TRAFFIC CONTROL ..... A00815-1 through 86

DOCUMENT A00820  
REQUEST FOR RELEASE OF MASSDOT AUTOCAD FILES FORM..... A00820-1 through 2

DOCUMENT A00875  
POLICY DIRECTIVE P-22-001 AND POLICY DIRECTIVE P-22-002 ..... A00875-1 through 8

DOCUMENT B00420  
PROPOSAL.....B00420-1 through 6

DOCUMENT B00842  
SCHEDULE OF PARTICIPATION BY MINORITY OR WOMEN BUSINESS  
ENTERPRISE (M/WBE) .....B00842-1 through 2

DOCUMENT B00843  
MINORITY OR WOMENS BUSINESS ENTERPRISE PARTICIPATION  
LETTER OF INTENT.....B00843-1 through 2

DOCUMENT B00846  
M/WBE OR SDVOBE JOINT CHECK ARRANGEMENT APPROVAL FORM.....B00846-1 through 2

DOCUMENT B00847  
JOINT VENTURE AFFIDAVIT .....B00847-1 through 4

\*\*\* END OF DOCUMENT \*\*\*

DOCUMENT 00102

**NOTICE TO CONTRACTORS**

Electronic proposals for the following project will be received through the internet using [www.bidx.com](http://www.bidx.com) until the date and time stated below and will be posted on [www.bidx.com](http://www.bidx.com) forthwith after the bid submission deadline. No paper copies of bids will be accepted. All Bidders must have a valid vendor code issued by MassDOT in order to bid on projects. Bidders need to apply for a Digital ID at least 14 days prior to a scheduled bid opening date with [www.bidx.com](http://www.bidx.com).

**TUESDAY, JANUARY 14, 2025 at 2:00 P.M. \*\***

**DISTRICT 2**

**Scheduled and Emergency Structural Repairs at Various Locations**

**\*\*Date Subject to Change**

PROJECT VALUE = \$1,816,000.00

Bidders must be pre-qualified by the Department in the BRIDGE - CONSTRUCTION category to bid on the above project. An award will not be made to a Contractor who is not pre-qualified by the Department prior to the opening of Proposals.

All prospective Bidders who intend to bid on this project must obtain “Request Proposal Form (R109)”. The blank “Request Proposal Form (R109)” can be obtained at: <https://www.mass.gov/prequalification-of-horizontal-construction-firms>.

All prospective Bidders must complete and e-mail an electronic copy of “Request Proposal Form (R109)” to the MassDOT Director of Prequalification for approval: [prequal.r109@dot.state.ma.us](mailto:prequal.r109@dot.state.ma.us).

Proposal documents for official bidders are posted on [www.bidx.com](http://www.bidx.com). Other interested parties may receive informational Contract Documents containing the Plans and Special Provisions, free of charge.

Bids will be considered, and the contract awarded in accordance with statutes governing such contracts in accordance with Massachusetts General Laws Chapter 30 § 39M.

The Project Bids File Attachments folder for proposals at [www.bidx.com](http://www.bidx.com) shall be used for submitting at the time of bid required information such as the Bid Bond required document, and other documents that may be requested in the proposal.

**NOTICE TO CONTRACTORS** (Continued)

All parties who wish to have access to information plans and specification must send a “Request for Informational Documents” to [MassDOTBidDocuments@dot.state.ma.us](mailto:MassDOTBidDocuments@dot.state.ma.us).

A Proposal Guaranty in the amount of 5% of the value of the bid is required.

This project is subject to the schedule of prevailing wage rates as determined by the Commissioner of the Massachusetts Department of Labor and Workforce Development, and the Division of Occupational Safety.

**PRICE ADJUSTMENTS**

This Contract contains price adjustments for hot mix asphalt and Portland cement mixtures, diesel fuel, and gasoline. For reference the base prices are as follows: liquid asphalt \$560.00 per ton, Portland cement \$425.53 per ton, diesel fuel \$2.697 per gallon, and gasoline \$2.388 per gallon, and Steel Base Price Index 378.2. MassDOT posts the **Price Adjustments** on their Highway Division’s website at

<https://www.mass.gov/massdot-contract-price-adjustments>

This Contract contains Price Adjustments for steel. See Document 00813 - PRICE ADJUSTMENT FOR STRUCTURAL STEEL AND REINFORCING STEEL for their application and base prices.

MassDOT projects are subject to the rules and regulations of the Architectural Access Board (521 CMR 1.00 et seq.)

Prospective bidders and interested parties can access this information and more via the internet at [WWW.COMMBUYS.COM](http://WWW.COMMBUYS.COM).

BY: Monica G. Tibbits-Nutt, Secretary and CEO, MassDOT  
Jonathan L. Gulliver, Administrator, MassDOT Highway Division  
SATURDAY, DECEMBER 7, 2024

## DOCUMENT 00210

REQUIREMENTS OF MASSACHUSETTS GENERAL LAWS  
CHAPTER 30, SECTION 39R;  
CHAPTER 30, SECTION 39O

July 1, 1981, updated October 2016

**M.G.L. c. 30, § 39R. Award of Contracts; Accounting Statements; Annual Financial Statements; Definitions.**

(a) The words defined herein shall have the meaning stated below whenever they appear in this section:

- (1) "Contractor" means any person, corporation, partnership, joint venture, sole proprietorship, or other entity awarded a contract pursuant to sections thirty-eight A1/2 to thirty-eight O, inclusive, of chapter seven and any contract awarded or executed pursuant to section eleven C of chapter twenty-five A, section thirty-nine M of chapter thirty, or sections forty-four A to forty-four H, inclusive, of chapter one hundred and forty-nine, which is for an amount or estimated amount greater than one hundred thousand dollars.
- (2) "Contract" means any contract awarded or executed pursuant to sections thirty-eight A1/2 to thirty-eight O, inclusive, of chapter seven and any contract awarded or executed pursuant to section eleven C of chapter twenty-five A, section thirty-nine M of chapter thirty, or sections forty-four A through forty-four H, inclusive, of chapter one hundred and forty-nine, which is for amount or estimated amount greater than one hundred thousand dollars.
- (3) "Records" means books of original entry, accounts, checks, bank statements and all other banking documents, correspondence, memoranda, invoices, computer printouts, tapes, discs, papers and other documents or transcribed information of any type, whether expressed in ordinary or machine language.
- (4) "Independent Certified Public Accountant" means a person duly registered in good standing and entitled to practice as a certified public accountant under the laws of the place of his residence or principal office and who is in fact independent. In determining whether an accountant is independent with respect to a particular person, appropriate consideration should be given to all relationships between the accountant and that person or any affiliate thereof. Determination of an accountant's independence shall not be confined to the relationships existing in connection with the filing of reports with the awarding authority.
- (5) "Audit", when used in regard to financial statements, means an examination of records by an independent certified public accountant in accordance with generally accepted accounting principles and auditing standards for the purpose of expressing a certified opinion thereon, or, in the alternative, a qualified opinion or a declination to express an opinion for stated reasons.
- (6) "Accountant's Report", when used in regard to financial statements, means a document in which an independent certified public accountant indicates the scope of the audit which he has made and sets forth his opinion regarding the financial statements taken as a whole with a listing of noted exceptions and qualifications, or an assertion to the effect that an overall opinion cannot be expressed. When an overall opinion cannot be expressed the reason therefor shall be stated. An accountant's report shall include as a part thereof a signed statement by the responsible corporate officer attesting that management has fully disclosed all material facts to the independent certified public accountant, and that the audited financial statement is a true and complete statement of the financial condition of the contractor.
- (7) "Management", when used herein, means the chief executive officers, partners, principals or other person or persons primarily responsible for the financial and operational policies and practices of the contractor.
- (8) Accounting terms, unless otherwise defined herein, shall have a meaning in accordance with generally accepted accounting principles and auditing standards.

(b) Subsection (a)(2) hereof notwithstanding, every agreement or contract awarded or executed pursuant to sections thirty-eight A 1/2 to thirty-eight O, inclusive, of chapter seven, or eleven C of chapter twenty-five A, and pursuant to section thirty-nine M of chapter thirty or to section forty-four A through H, inclusive, of chapter one hundred and forty-nine, shall provide that:

- (1) The contractor shall make, and keep for at least six years after final payment, books, records, and accounts which in reasonable detail accurately and fairly reflect the transactions and dispositions of the contractor, and
- (2) Until the expiration of six years after final payment, the office of inspector general, and the commissioner of capital asset management and maintenance shall have the right to examine any books, documents, papers or records of the contractor or of his subcontractors that directly pertain to, and involve transactions relating to, the contractor or his subcontractors, and
- (3) If the agreement is a contract as defined herein, the contractor shall describe any change in the method of maintaining records or recording transactions which materially affect any statements filed with the awarding authority, including in his description the date of the change and reasons therefor, and shall accompany said description with a letter from the contractor's independent certified public accountant approving or otherwise commenting on the changes, and
- (4) If the agreement is a contract as defined herein, the contractor has filed a statement of management on internal accounting controls as set forth in paragraph (c) below prior to the execution of the contract, and
- (5) If the agreement is a contract as defined herein, the contractor has filed prior to the execution of the contracts and will continue to file annually, an audited financial statement for the most recent completed fiscal year as set forth in paragraph (d) below.

(c) Every contractor awarded a contract shall file with the awarding authority a statement of management as to whether the system of internal accounting controls of the contractor and its subsidiaries reasonably assures that:

- (1) transactions are executed in accordance with management's general and specific authorization;
- (2) transactions are recorded as necessary
  - i. to permit preparation of financial statements in conformity with generally accepted accounting principles, and
  - ii. to maintain accountability for assets;
- (3) access to assets is permitted only in accordance with management's general or specific authorization; and
- (4) the recorded accountability for assets is compared with the existing assets at reasonable intervals and appropriate action was taken with respect to any difference.

Every contractor awarded a contract shall also file with the awarding authority a statement prepared and signed by an independent certified public accountant, stating that he has examined the statement of management on internal accounting controls, and expressing an opinion as to:

- (1) whether the representations of management in response to this paragraph and paragraph (b) above are consistent with the result of management's evaluation of the system of internal accounting controls; and
- (2) whether such representations of management are, in addition, reasonable with respect to transactions and assets in amounts which would be material when measured in relation to the applicant's financial statements.





THIS PAGE INTENTIONALLY LEFT BLANK

DOCUMENT 00331

# LOCUS MAP

## DISTRICT 2 Scheduled and Emergency Structural Repairs at Various Locations

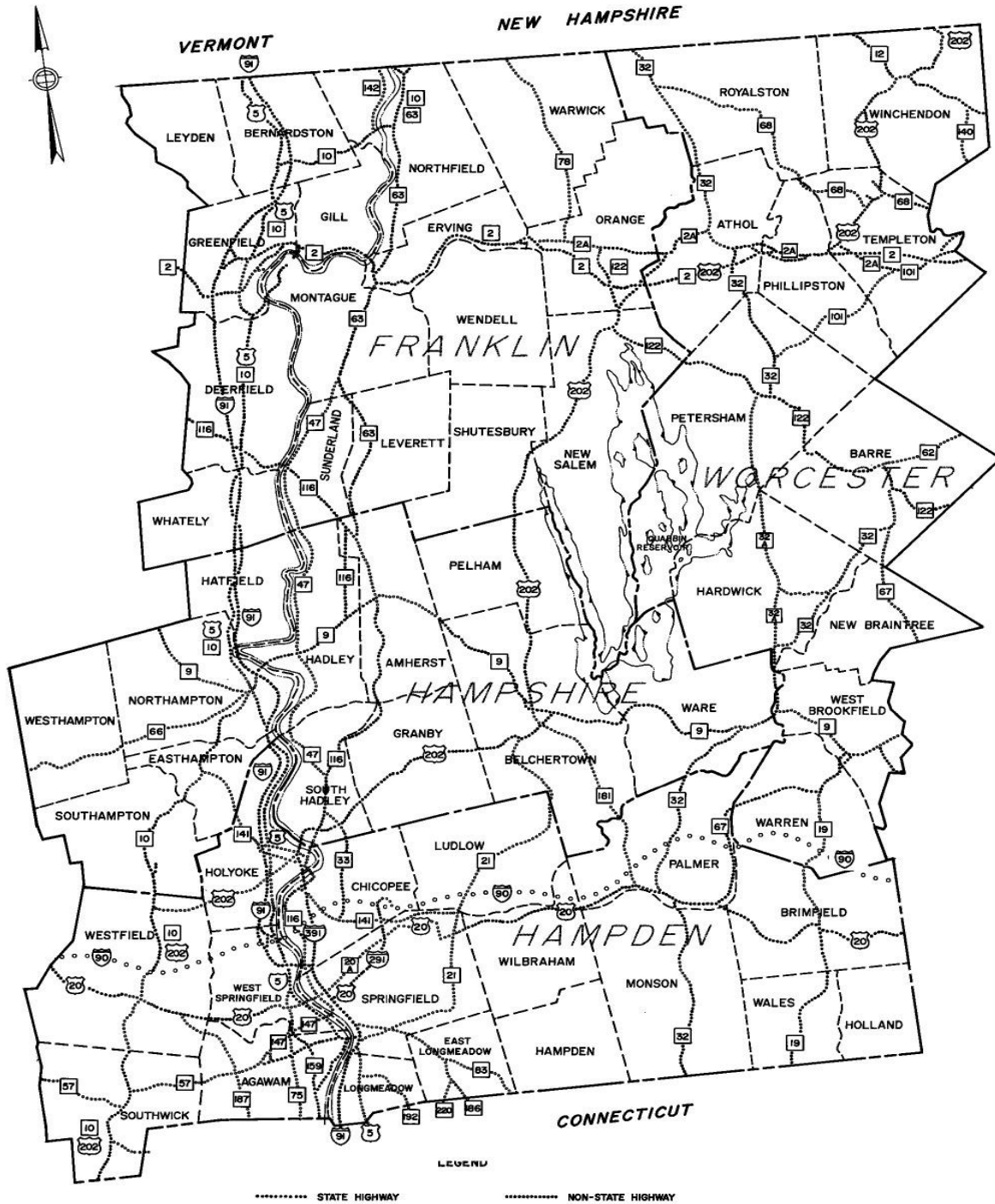

NOT TO SCALE

THIS PAGE IS INTENTIONALLY LEFT BLANK

DOCUMENT 00439



Final Report

Interim Report

### CONTRACTOR PROJECT EVALUATION FORM

*For instructions on using this form, see Engineering Directive E-10-002, Dated 4/20/2010*

Date: \_\_\_\_\_

City/Town: \_\_\_\_\_

Contractor: \_\_\_\_\_

Project: \_\_\_\_\_

Address: \_\_\_\_\_

F.A. No. \_\_\_\_\_

Contract Number: \_\_\_\_\_

Bid Price: \_\_\_\_\_

Notice to Proceed: \_\_\_\_\_

Funds: State: \_\_\_\_\_ Fed Aid: \_\_\_\_\_

Current Contract Completion Date: \_\_\_\_\_

Date Work Started: \_\_\_\_\_

Date Work Completed\*: \_\_\_\_\_

Contractor's Superintendent: \_\_\_\_\_

Division: (indicates class of work) Highway: \_\_\_\_\_ Bridge: \_\_\_\_\_ Maintenance: \_\_\_\_\_

\*If work was NOT completed within specified time (including extensions) give reasons on following page.

	Excellent 10	Very Good 9	Average 8	7	Fair 6	5	Poor 4	% Rating
<b>1. Workmanship</b>								x 2=
<b>2. Safety</b>								x 2=
<b>3. Schedule</b>								x 1.5=
<b>4. Home Office Support</b>								x 1=
<b>5. Subcontractors Performance</b>								x 1=
<b>6. Field Supervision/ Superintendent</b>								x 1=
<b>7. Contract Compliance</b>								x 0.5=
<b>8. Equipment</b>								x 0.5=
<b>9. Payment of Accounts</b>								x 0.5=
<b>(use back for additional comments)</b>							<b>Overall Rating:</b>	

*(Give explanation of items 1 through 9 on the following page in numerical order if overall rating is below 80%. Use additional sheets if necessary.)*

\_\_\_\_\_  
District Construction Engineer's Signature/Date

\_\_\_\_\_  
Resident Engineer's Signature/Date

\_\_\_\_\_  
Contractor's Signature Acknowledging Report/Date

Contractor Requests Meeting with the District: No  Yes  Date Meeting Held: \_\_\_\_\_

Contractor's Comments/Meeting Notes (extra sheets may be added to this form and noted here if needed): \_\_\_\_\_

\_\_\_\_\_  
\_\_\_\_\_

**CONTRACTOR PROJECT EVALUATION FORM (Continued)**

Date: \_\_\_\_\_ Contract Number: \_\_\_\_\_

**INFORMATION FOR DISTRICT HIGHWAY DIRECTORS RELATING TO PREQUALIFICATION**

A deduction shall be recommended for unsatisfactory performance if computed overall rating is under 80%.

A deduction may be recommended for this project being completed late due to the Contractor's fault.

**RECOMMENDATIONS FOR DEDUCTIONS FROM CONTRACTORS' ASSIGNED FACTOR**

*(Write Yes or No in space provided)*

I recommend a deduction for Contractor's unsatisfactory performance: \_\_\_\_\_

I recommend a deduction for project completed late: \_\_\_\_\_

Signed: \_\_\_\_\_

District Highway Director

EXPLANATION OF RATINGS 1 - 9: \_\_\_\_\_

---



---



---



---



---



---



---



---



---



---



---



---



---



---



---



---



---



---



---



---



---



---

WORK NOT COMPLETED WITHIN SPECIFIED TIME: \_\_\_\_\_

---



---



---



---



---



---



---



---



---



---



Final Report

Interim Report

## SUBCONTRACTOR PROJECT EVALUATION FORM

*For instructions on using this form, see Engineering Directive E-10-002, Dated 4/20/2010*

Date: \_\_\_\_\_

City/Town: \_\_\_\_\_

Subcontractor: \_\_\_\_\_

Project: \_\_\_\_\_

Address: \_\_\_\_\_

F.A. No.: \_\_\_\_\_

Contract Number: \_\_\_\_\_

Prime Contractor \_\_\_\_\_

Current Contract Completion Date: \_\_\_\_\_

Date Work Started: \_\_\_\_\_

Date Work Completed\*: \_\_\_\_\_

Subcontractor's Superintendent: \_\_\_\_\_

Type of Work Performed by Subcontractor: \_\_\_\_\_

\*If work was NOT completed within specified time (including extensions) give reasons on following page.

	Excellent 10	Very Good 9	Average 8	7	Fair 6	5	Poor 4	% Rating
<b>1. Workmanship</b>								x 2=
<b>2. Safety</b>								x 2=
<b>3. Schedule</b>								x 1.5=
<b>4. Home Office Support</b>								x 1.5=
<b>5. Field Supervision/ Superintendent</b>								x 1=
<b>6. Contract Compliance</b>								x 1=
<b>7. Equipment</b>								x 0.5=
<b>8. Payment of Accounts</b>								x 0.5=
<b>(use back for additional comments)</b>							<b>Overall Rating:</b>	

*(Give explanation of items 1 through 8 on the following page in numerical order if overall rating is below 80%. Use additional sheets if necessary.)*

\_\_\_\_\_  
District Construction Engineer's Signature/Date

\_\_\_\_\_  
Resident Engineer's Signature/Date

\_\_\_\_\_  
Contractor Signature Acknowledging Report/Date

\_\_\_\_\_  
Subcontractor Signature Acknowledging Report/Date

Subcontractor Requests Meeting with the District: No  Yes  Date Meeting Held: \_\_\_\_\_

Subcontractor's Comments / Meeting Notes (extra sheets may be added to this form and noted here if needed): \_\_\_\_\_

\_\_\_\_\_

Contractor's Comments: \_\_\_\_\_

\_\_\_\_\_

**SUBCONTRACTOR PROJECT EVALUATION FORM (Continued)**

Date: \_\_\_\_\_ Contract Number: \_\_\_\_\_

**INFORMATION FOR DISTRICT HIGHWAY DIRECTORS RELATING TO PREQUALIFICATION**

A deduction shall be recommended for unsatisfactory performance if computed overall rating is under 80%.  
A deduction may be recommended for this project being completed late due to the Contractor's fault.

**RECOMMENDATIONS FOR DEDUCTIONS FROM CONTRACTORS' ASSIGNED FACTOR**

*(Write Yes or No in space provided)*

I recommend a deduction for Contractor's unsatisfactory performance: \_\_\_\_\_

I recommend a deduction for project completed late: \_\_\_\_\_

Signed: \_\_\_\_\_  
District Highway Director

EXPLANATION OF RATINGS 1 – 8: \_\_\_\_\_

\_\_\_\_\_  
\_\_\_\_\_  
\_\_\_\_\_  
\_\_\_\_\_  
\_\_\_\_\_  
\_\_\_\_\_  
\_\_\_\_\_  
\_\_\_\_\_  
\_\_\_\_\_  
\_\_\_\_\_  
\_\_\_\_\_  
\_\_\_\_\_  
\_\_\_\_\_  
\_\_\_\_\_  
\_\_\_\_\_  
\_\_\_\_\_  
\_\_\_\_\_  
\_\_\_\_\_  
\_\_\_\_\_  
\_\_\_\_\_  
\_\_\_\_\_

WORK NOT COMPLETED WITHIN SPECIFIED TIME: \_\_\_\_\_

\_\_\_\_\_  
\_\_\_\_\_  
\_\_\_\_\_  
\_\_\_\_\_  
\_\_\_\_\_  
\_\_\_\_\_  
\_\_\_\_\_  
\_\_\_\_\_  
\_\_\_\_\_  
\_\_\_\_\_  
\_\_\_\_\_

Revised: 04/28/17

\*\*\* END OF DOCUMENT \*\*\*



DOCUMENT 00710  
GENERAL CONTRACT PROVISIONS  
Revised: 05/06/24

NOTICE OF AVAILABILITY

The STANDARD SPECIFICATIONS FOR HIGHWAYS AND BRIDGES dated 2024, the SUPPLEMENTAL SPECIFICATIONS, the 1996 METRIC CONSTRUCTION AND TRAFFIC STANDARD DETAILS, the 1990 STANDARD DRAWINGS FOR SIGNS AND SUPPORTS; the 1968 STANDARD DRAWINGS FOR TRAFFIC SIGNALS AND HIGHWAY LIGHTING and the 2017 CONSTRUCTION STANDARD DETAILS are available online at <https://www.mass.gov/massdot-highway-division-manuals-and-publications>

SPECIAL PROVISIONS FOR RIGHT-TO-KNOW ACT REQUIREMENTS

The Contractor's attention is directed to Massachusetts General Laws, Chapter 111F, commonly known as the Right-To-Know Act, and to the regulations promulgated pursuant thereto. Among the provisions of the Right-To-Know Act is a requirement that employers make available to employees Materials Safety Data Sheets (MSDS) for any substance on the Massachusetts Substance List (MSL) to which employees are, have been, or may be exposed.

To ensure prompt compliance with these regulations and legislation, the Contractor shall:

1. Deliver to the Department, prior to the start of any work under this contract, copies of MSDS for all MSL substances to be used, stored, processed or manufactured at the worksite by the Contractor.
2. Train employees of the Department, who may be exposed to MSL substances as a result of the Contractor's work under this contract, with regard to those specific substances in accordance with requirements of the Right-To-Know Act.
3. Observe all safety precautions recommended on the MSDS for any MSL substance to be used, stored, processed, or manufactured at the worksite by the Contractor.
4. Inform the Department in writing regarding specific protective equipment recommended in the MSDS for MSL substances to which employees of the Department may be exposed as a result of the Contractor's work under this contract.

The Department shall not be liable for any delay or suspension of work caused by the refusal of its employees to perform any work due to the Contractor's failure to comply with the Right-To-Know Act. The Contractor agrees to hold the Department or the Commissioner of the Department harmless and fully indemnified for any and all claims, demands, fines, actions, complaints, and causes of action resulting from or arising out of the Contractor's failure to comply with the requirements of the Right-To-Know Act.

ALTERNATIVE DISPUTE RESOLUTION

Forum, Choice of Law and Mediations:

Any actions arising out of a contract shall be governed by the laws of Massachusetts and shall be brought and maintained in a State or federal court in Massachusetts which shall have exclusive jurisdiction thereof. MassDOT and the Contractor may both agree to mediation of any claim and will share the costs of such mediation pro rata based on the number of parties involved.

\*\*\* END OF DOCUMENT \*\*\*

THIS PAGE IS INTENTIONALLY LEFT BLANK

DOCUMENT 00715



## SUPPLEMENTAL SPECIFICATIONS

SEPTEMBER 30, 2024

The 2024 *Standard Specifications for Highways and Bridges* are amended by the following modifications, additions and deletions. These Supplemental Specifications prevail over those published in the Standard Specifications.

The Specifications Committee has issued these Supplemental Specifications for inclusion into each proposal until such time as they are updated or incorporated into the next Standard Specifications.

Contractors are cautioned that these Supplemental Specifications are dated and will change as they are updated.

### DIVISION I

### GENERAL REQUIREMENTS AND COVENANTS

#### SECTION 1: DEFINITION OF TERMS

Subsection 1.03: Defined Terms

*Under Part of the First Part replace the words Chapter 90 of the General Laws with MGL Chapter 6C, Section 4[b].*

#### SECTION 2: PROPOSAL REQUIREMENTS AND CONDITIONS

Subsection 2.01: Proposal Forms and Plans

*Replace the first paragraph under A. Prequalification Prior to Requesting Proposal Forms with the following:*

Subject to the requirements of M.G.L. Chapter 81, Section 8B, each prospective Bidder proposing to bid on any work, excepting the construction, reconstruction, repair or alteration of buildings, to be awarded by the Department or by a municipality under the provisions of M.G.L. Chapter 6C, Section 4(b) must be prequalified in accordance with 700 CMR 14.00 Prequalification of contractors and subcontractors, if the amount of the proposal added to the value of the uncompleted work already under contract with the Department will aggregate \$50,000 or more.

*Replace the second paragraph under B. Issuance of Proposal Forms and Plans with the following:*

For projects to be awarded under the provisions of M.G.L. Chapter 6C, Section 4(b), bidders may obtain plans and specifications from the applicable municipality at the place specified in the Notice to Contractors.

#### SECTION 4: SCOPE OF WORK

Subsection 4.04: Changed Conditions

*Replace the last paragraph with the following.*

The provisions of Section 39N of Chapter 30 of the General Laws, as amended, do not apply to construction contracts entered into on behalf of a municipality under the provisions of M.G.L. Chapter 6C, Section 4(b).

Subsection 4.06: Increased or Decreased Contract Quantities

*Replace the second paragraph with the following.*

Where the actual quantity of a pay item varies by more than 25% above or below the estimated quantity stated in the Contract, an equitable adjustment in the Contract Price for that pay item shall be negotiated upon demand of either party regardless of the cause of the variation in quantity. A demand for an equitable adjustment must be submitted to the other party within 30 days after beginning the work of the affected item that is greater than 25% above the bid quantity or within 30 days after completing the work when the actual quantity is 25% less than the bid quantity.

## **SECTION 9: MEASUREMENT AND PAYMENT**

Subsection 9.03: Payment for Extra Work

*Replace paragraph B., (2) with the following.*

- (2) Plus 13 percent of direct labor, for the actual costs of Federal Insurance Contribution Act (FICA) including Medicare; Federal Unemployment Tax Act (FUTA); State Unemployment Tax Act (SUTA), which includes Unemployment Insurance, the Workforce Training Fund Program, ~~and~~ Employer Medical Assistance Contribution, and COVID-19 Recovery Assessment; Earned Sick Time (EST) Law (940 CMR 33.00); and Paid Family and Medical Leave (PFML) Act (458 CMR 2.00); or, as an alternative to the above 13 percent, the Contractor may elect to use actual rates for FICA, FUTA, SUTA, EST and PFML provided the actual rates are supported with verifiable documentation and shall be subject to review by MassDOT Audit Operations.

Subsection 9.04: Partial Payments

*Replace the last sentence of the first paragraph with the following;*

No such estimates or payment shall be required to be made when, in the Engineer's judgment, the work is not proceeding in accordance with the provisions of the Contract, or when in their judgment the total value of the work completed since the last estimate amounts to less than \$5,000.00.

## DIVISION II

### CONSTRUCTION DETAILS

#### DIVISION II: Construction Details

Replace M4.02.15 Cement Mortar with M4.04.0 Grout, Mortar, and Concrete Products where encountered, including in Subsections 230.40, 485.40, 501.40, 685.40, 940.40A and 983.40.

### SECTION 100: EARTHWORK, GRADING, DEMOLITION, RODENT CONTROL AND BORINGS

#### SUBSECTION 150: EMBANKMENT

##### Subsection 150.62: Embankment Construction with Materials Other Than Rock

Replace the fourth paragraph with the following.

The embankment materials shall be compacted to not less than 95% of the maximum dry density of the embankment material as determined by AASHTO T 99, Method C. If required, a correction for oversized particles shall be in accordance with Annex A of AASHTO T 99. If the material retained on the  $\frac{3}{4}$ -in. sieve is 30% or more of the total sample, this test shall not apply and the material shall be compacted to the target density. The target density shall be established by determining the number of passes of a roller required to produce a constant and uniform density, after conducting a series of tests using either AASHTO T 310, *In-Place Density and Moisture Content of Soil and Soil-Aggregate by Nuclear Methods (Shallow Depth)*, AASHTO T 191, *Density of Soil In-Place by the Sand-Cone Method*, or *ASTM D 8167 Standard Test Method for In-Place Bulk Density of Soil and Soil-Aggregate by a Low-Activity Nuclear Method (Shallow Depth)*. The Contractor shall, without additional compensation, employ whatever measures may be necessary to adjust the natural water content of the suitable embankment material to permit the placement and compaction as hereinbefore specified.

#### SUBSECTION 160: CONTROLLED LOW-STRENGTH MATERIAL

##### Subsection 160: Controlled Low-Strength Material

Add this new subsection.

##### DESCRIPTION

###### **160.20: General**

Controlled Low-Strength Material shall be installed in accordance with the relevant provisions of Subsection 150: Embankment, Section 901: Cement Concrete and in accordance with the procedures described herein.

Controlled Low Strength Materials (CLSM) shall be a self-compacting, self-leveling, flowable, excavatable or non-excavatable, low strength, rigid setting, and unshrinkable material, used as an alternative to compacted granular fills, including backfill, structural fill, utility fill, pavement base, subgrade, subbase, base course, conduit bedding, erosion control, and void filling.

##### MATERIALS

###### **160.40: General**

Material for controlled low-strength material shall meet the requirement specified of M4.08.0 Controlled Low-Strength Material. The material shall be specified by the Engineer as one of the following types;

- CLSM – Manual Excavatable ( $\leq 100$  psi)
- CLSM – Mechanical Excavatable (101-300 psi)
- CLSM – Structural Non Excavatable ( $> 300$  psi)

Permeability testing as specified in Table M4.08.0-2 shall be required when the material is placed outside of roadway areas or footings for concrete structures, or as directed by the Engineer.

### CONSTRUCTION METHODS

#### 160.60: General

The Contractor shall submit a placement plan for Controlled Low-Strength Material (CLSM). The plan shall include the type of CLSM, detailed descriptions of methods used for placing and containing the controlled density fill and the set time to strength.

The Contractor shall remove all debris prior to placing the fill. Fill shall not be placed against any structural elements or utilities unless approved by the Engineer.

CLSM shall be poured in lifts not exceeding 4 feet to insure stability under the fluid effects of the pour. Care shall be taken to ensure the integrity of the forms or other means of supporting the material until the material sets up.

### COMPENSATION

#### 160.80: Method of Measurement

Controlled Low-Strength Material shall be measured by the cubic yard in place to the neat lines established on the plans or specified by the Engineer. When backfilling pipes the horizontal neat lines shall be not greater than 3.0 ft. greater than the rated inside diameter of the pipe and vertically from the top of the crushed stone foundation material, if any, or 6 in. below the pipe invert whichever is less to the specified top elevation. A deduction shall be made for the volume of the pipe or conduit encased.

#### 160.81: Basis of Payment

Payment under this item shall constitute full compensation for the placement, testing, and all material, equipment and labor to complete the work.

#### 160.82: Payment Items

- 160.1      Controlled Low-Strength Material - ..... Cubic Yard  
                  Manual Excavatable ( $\leq 100$  PSI)
- 160.2      Controlled Low-Strength Material – ..... Cubic Yard  
                  Mechanical Excavatable (101-300 PSI)
- 160.3      Controlled Low-Strength Material ( $>300$  PSI) ..... Cubic Yard

## SECTION 200: DRAINAGE

### SUBSECTION 201: BASINS, MANHOLES AND INLETS

#### Subsection 201.40: General

Replace "Cement Mortar ..... M4.02.15" with "Mortar ..... M4.04.0".

---

## **SECTION 400: SUB-BASE, BASE COURSES, SHOULDERS, PAVEMENTS AND BERMS**

### **SUBSECTION 401: GRAVEL SUB-BASE**

#### Subsection 401.60: Gravel Sub-base

*Replace the last sentence of the first paragraph with the following.*

The specific density of the Gravel Sub-base shall be maintained by determining the number of passes of a roller required to produce a constant and uniform density, after conducting a series of tests using a nuclear device or the sand/volume method in accordance with AASHTO T310, AASHTO T 191, or ASTM D 8167.

### **SUBSECTION 402: DENSE GRADED CRUSHED STONE FOR SUB-BASE**

#### Subsection 402.61: Spreading and Compacting

*Replace the last sentence of the first paragraph with the following.*

The specified density of the Dense Graded Crushed Stone shall be maintained by determining the number of passes of a roller are required to produce a constant and uniform density, after conducting a series of tests using a nuclear device or the sand/volume method in accordance with AASHTO T310, AASHTO T 191, or ASTM D 8167.

### **SUBSECTION 403: RECLAIMED PAVEMENT FOR BASE COURSE AND/OR SUB-BASE**

#### Subsection 403.64: Compaction and Dust Control

*Replace the second paragraph with the following.*

The reclaimed base course shall be tested for compaction and smoothness and accuracy of grade in accordance with the applicable provisions of 401.60: Gravel Sub-base. The required density shall be measured by using a nuclear device or the sand/volume method in accordance with AASHTO T310, AASHTO T 191, or ASTM D 8167. If any portions are found to be unacceptable by the Engineer, such portions shall be reprocessed, regraded, and recompacted until the required smoothness and accuracy are obtained.

### **SUBSECTION 404: RECLAIMED PAVEMENT BORROW MATERIAL**

#### Subsection 404.60: General

*Replace the second sentence with the following.*

The specified density of the Reclaimed Pavement Borrow Material shall be maintained by determining the number of passes of a roller that are required to produce a constant and uniform density, after conducting a series of tests using a nuclear device or the sand/volume method in accordance with AASHTO T310, AASHTO T 191, or ASTM D 8167

### **SUBSECTION 450: HOT MIX ASPHALT PAVEMENT**

#### Subsection 450.40: General

*Add the following paragraph to the end of this subsection.*

Prior to placing hot mix asphalt the contractor shall provide notice to the Engineer at least 48 hours in advance of the work. The notice shall include the anticipated schedule, HMA tonnage, the type of mix, the mix provider and plant location.

### **SUBSECTION 460: HOT MIX ASPHALT PAVEMENT FOR LOCAL ROADS**

#### Subsection 460.40: General

*Add the following paragraph to the end of this subsection.*

Prior to placing hot mix asphalt the contractor shall provide notice to the Engineer at least 48 hours in advance of the work. The notice shall include the anticipated schedule, HMA tonnage, the type of mix, the mix provider and plant location.

## **SUBSECTION 466: STRESS ABSORBING MEMBRANE & STRESS ABSORBING MEMBRANE INTERLAYER**

### Subsection 466.40: General

*Replace this subsection with the following.*

Prior to placing stress absorbing membrane the contractor shall provide notice to the Engineer at least 48 hours in advance of the work. The notice shall include the anticipated schedule, tonnage, the type of mix, the mix provider and plant location. Stress absorbing membrane and stress absorbing membrane interlayer shall be constructed as specified herein.

## **SUBSECTION 470: HOT MIX ASPHALT PAVEMENT BERM**

### Subsection 470.40: General

*Replace this subsection with the following.*

Prior to placing hot mix asphalt the contractor shall provide notice to the Engineer at least 48 hours in advance of the work. The notice shall include the anticipated schedule, HMA tonnage, the type of mix, the mix provider and plant location. The Contractor shall obtain HMA berm material of the type specified.

## **SUBSECTION 472: TEMPORARY ASPHALT PATCHING**

### Subsection 472.40: General

*Add the following paragraph to the beginning of this subsection.*

Prior to placing hot mix asphalt the contractor shall provide notice to the Engineer at least 48 hours in advance of the work. The notice shall include the anticipated schedule, HMA tonnage, the type of mix, the mix provider and plant location.

## **SUBSECTION 486: ULTRATHIN BONDED OVERLAY**

### Subsection 486.40: General

*Add the following paragraph to the end of this subsection.*

Prior to placing ultrathin bonded overlay the contractor shall provide notice to the Engineer at least 48 hours in advance of the work. The notice shall include the anticipated schedule, tonnage, the type of mix, the mix provider and plant location.

## **SECTION 600: HIGHWAY GUARD, FENCES AND WALLS**

### **SUBSECTION 690: WALLS REMOVED AND RESET**

#### Subsection 690.40: General

*Replace the last sentence with the following.*

Mortar shall meet the requirement of M4.04.0: Grout, Mortar, and Concrete Products.

## **SECTION 700: INCIDENTAL WORK**

### **SUBSECTION 702: HOT MIX ASPHALT SIDEWALKS AND DRIVEWAYS**

#### Subsection 702.40: General

*Add the following paragraph to the end of this subsection.*

Prior to placing hot mix asphalt the contractor shall provide notice to the Engineer at least 48 hours in advance of the work. The notice shall include the anticipated schedule, HMA tonnage, the type of mix, the mix provider and plant location.



## SECTION 800: TRAFFIC CONTROL DEVICES

### SUBSECTION 825: RECTANGULAR RAPID FLASHING BEACONS

Subsection 825: Rectangular Rapid Flashing Beacons

*Add this new subsection.*

#### DESCRIPTION

##### **825.20: General**

This work shall consist of furnishing and installing a solar-powered, actuated, Rectangular Rapid Flashing Beacon (RRFB) system at the location(s) shown in the Plans.

#### MATERIALS

##### **825.40: General**

Rectangular Rapid-Flashing Beacons shall meet the requirements specified in the following Subsections of Division III, Materials:

Cement Concrete.....	M4.02.00
Signal Posts and Bases .....	M10.05.1
APS Pushbuttons.....	M10.09.1
RRFB Assemblies.....	M10.11.0

An RRFB system shall include the following items (quantities shown in the Major Items List found in the Plans):

- Cement Concrete Foundation
- Signal Post and Pedestal Base
- APS Pushbutton
- Light Bar
- Signage
- Enclosure for Controller, Activation Unit, and Battery System
- Solar Panel
- All mounting and supporting hardware and wiring necessary to complete a working system

The Contractor shall supply cement concrete foundations per the Plans.

The Contractor shall supply Schedule 80 aluminum signal posts with a brushed or spun finish and square, pedestal aluminum bases with a natural finish unless otherwise shown in the Plans or Special Provisions.

Each Light Bar shall have a pair of yellow beacons facing one or both directions of traffic, as shown in the Plans.

All sign designs shall conform to the MUTCD. Sign panel information, including dimensions, shall be per the Plans.

The warning signs (MUTCD code W11-2, W11-15, or S1-1 signs – see Plans for sign type), and the diagonal downward arrow sign (W16-7P) signs shall be on Type A substrate, conforming to 828.42: Panels. The sign sheeting shall be fluorescent yellow-green, conforming to ASTM D4956 Type IX.

An R10-25 sign, conforming to the MUTCD, shall be mounted above the APS Pushbutton on a Type A substrate or may be integral to the button assembly.

The solar panel and battery system may be integrated into a single unit or housed separately, per the manufacturer’s design. These may also be co-housed with the Light Bar and/or the Controller and Activation Unit.

The solar panel and battery system shall be sized appropriately to accommodate 300 actuations per day, 365 days a year, for the duration of the repeating flashing sequence shown in the Plans. The sizing calculations shall be based upon solar and temperature conditions for a typical December-January in Massachusetts. The system shall have a minimum autonomy of 5 days.

Each assembly shall be rated for wind speeds of up to 90 mph.

Any proprietary software required for the programming and/or operation of the system during its lifetime shall be included at no additional cost.

#### **825.41: Shop Drawings**

Within 30 days from the Notice to Proceed the Contractor shall submit shop drawings for the RRFB system, including cutsheets for all components to show conformance with M10.05, M10.09.1, and M10.11.0 and these specifications.

Shop drawings shall include all solar and battery sizing calculations. These calculations shall have Contractor- or manufacturer-supplied, site-specific shading factors applied.

#### **825.42: Material Warranties**

All RRFB components shall include a minimum 1-year manufacturer's replacement warranty for manufacturing or installation defects starting at the date of acceptance by the Engineer. A battery shall be considered defective should it not retain 80% of its original capacity within the warranty period.

### CONSTRUCTION METHODS

#### **825.60: General**

RRFBs shall be installed on new foundations at the locations as shown in the Plans. Bases shall be secured to the foundation in accordance with the manufacturer's specifications.

All systems shall be installed per the manufacturer's instructions.

The location and orientation of the system shall be per the Plans.

The arrow on each APS pushbutton shall be aligned parallel to the direction of travel of the crosswalk.

The Light Bar(s) shall be oriented towards the incoming lane(s).

Solar panels shall be oriented to maximize sunlight gain.

### SYSTEM OPERATION

#### **825.70: APS Pushbuttons**

APS Pushbuttons shall actuate the RRFB system. Upon actuation, an audible speech message shall be broadcast from each pushbutton in the system that says, "Warning lights are flashing," shall be stated twice. This message shall be repeated upon each actuation. No other messages shall be allowed.

While the system is in dark mode, the APS Pushbuttons shall broadcast a locator tone. The locator tone shall have a duration of 0.15 seconds or less and shall repeat at 1-second intervals at all times that the system is in dark mode. The locator tone shall be set 2 to 5 dBA above ambient sound, shall automatically adjust intensity, but cap at a maximum volume of 100 dBA.

APS Pushbuttons shall have all other vibrotactile and percussive indications disabled.

#### **825.71: Light Bar**

The Light Bar shall remain dark until actuated.

Upon actuation, all Light Bars in the system shall be activated simultaneously for a predetermined repeating flash sequence. The flashing rate shall be 75 flashing sequences per minute.

The left and right yellow beacons shall operate using the following sequence:

- A. The yellow beacon on the left-hand side shall be illuminated for approximately 50 milliseconds.
- B. Both yellow beacons shall be dark for approximately 50 milliseconds.
- C. The yellow beacon on the right-hand side shall be illuminated for approximately 50 milliseconds.
- D. Both yellow beacons shall be dark for approximately 50 milliseconds.
- E. The yellow beacon on the left-hand side shall be illuminated for approximately 50 milliseconds.
- F. Both yellow beacons shall be dark for approximately 50 milliseconds.
- G. The yellow beacon on the right-hand side shall be illuminated for approximately 50 milliseconds.
- H. Both yellow beacons shall be dark for approximately 50 milliseconds.
- I. Both yellow beacons shall be illuminated for approximately 50 milliseconds.
- J. Both yellow beacons shall be dark for approximately 50 milliseconds.
- K. Both yellow beacons shall be illuminated for approximately 50 milliseconds.
- L. Both yellow beacons shall be dark for approximately 250 milliseconds.

The flash rate of each individual RRFB indication, as applied over the full flashing sequence, shall not be more than 5 flashes per second, to avoid frequencies that might cause seizures.

The sequence shall then be repeated until the duration time has been met and then all yellow beacons shall return to dark mode simultaneously. The duration time shall be per the Plans.

The predetermined repeating flash sequence shall be immediately initiated every time a pushbutton detector is actuated. If the RRFBs are already flashing and an actuation is received, it shall restart the duration time. There shall be no delay time programmed between actuations.

COMPENSATION

**825.80: Method of Measurement**

RRFBs will be measured as a single system, 2-Post Assembly or 3-Post Assembly, furnished and installed.

**825.81: Basis of Payment**

The work will be paid for at the contract price each under the respective item for a 2-Post Assembly System or 3-Post Assembly System. Any additional wiring, mounting equipment, or other materials or labor required to for an operating system per the Plans and Specifications shall be considered as incidental to the construction and be included in the contract price.

**825.82: Payment Item**

825.2	RRFB (2-Post Assembly System) .....	Each
825.3	RRFB (3-Post Assembly System) .....	Each

**SECTION 900: STRUCTURES**

Subsection 922: Elastomeric Bearing Pads

*Add this new subsection.*

**SUBSECTION 922: ELASTOMERIC BEARING PADS**

DESCRIPTION

**922.20: General**

This specification consists of the construction requirements for elastomeric bearing pads. Elastomeric bearing pads shall consist of plain or laminated bearings consisting of layers of elastomers restrained at their interfaces by bonded steel laminates.

MATERIALS

**922.40: General**

Elastomeric bearing pads shall meet the following requirements:

Elastomeric Bearing Pads .....	M9.14.5
Anchor bolts .....	M8.01.5

CONSTRUCTION METHODS

**922.50: Submittals**

The Contractor shall submit the following to the Engineer for approval:

1. Prior to fabrication:
  - a. Written notification 30 days prior to the start of bearing production. The notification shall include the contract number, quantity, type, and size of bearing being produced, manufacturer’s name, and the name of the independent testing lab.
  - b. Shop drawings for approval in accordance with Subsection 5.02, 14 days prior to the start of bearing production.
2. At the time of bearing pad delivery:
  - a. A certificate of compliance (COC) certifying that the elastomeric bearing pads meet the requirements of the contract specifications. The COC shall be accompanied by:
    - A mill certificate for steel laminates used in bearings, where applicable.
    - Fabricator QC test reports.
  - b. Independent test results as required under Subsection 922.62.

**922.51: Fabricators**

Fabricators shall be in accordance with Subsection M9.14.5D.

**922.52: Fabrication**

Fabrication shall be in accordance with Subsection M9.14.5E.

In addition to the number of bearing pads required for the contract the Contractor shall order additional bearing pads as defined in Subsection M9.14.5G, in order to allow the Engineer to randomly select a bearing pad for testing in accordance with 922.72.

**922.53: Packaging, Handling, & Storage**

The bearing pads shall be packaged, handled, and stored in accordance with Subsection M9.14.5F.

All bearing devices and components shall be stored on the project in an area that provides protection from environmental and physical damage. When installed, bearings shall be clean and free of all foreign substances.

**922.54 Installation**

Bearing pads shall be installed only on concrete bridge seat bearing areas that have been prepared in accordance with Subsection 901.65A(3).

Bearing pads shall be installed by qualified personnel to the positions, elevations, and slopes shown on the plans and to the dimensions and offsets prescribed by the manufacturer. The bearing pads shall be adjusted, as necessary, to take into account the ambient temperature at installation and future movements of the bridge due to temperature changes, release of falsework, and shortening due to post-tensioning.

Elastomeric bearings shall be placed directly on the concrete surface provided that it is flat within the bearing area to within a tolerance of 0.005 times the smallest nominal dimension of the bearing as measured by a straight edge from peak to valley. Bearings shall be placed on surfaces that do not deviate from the specified bridge seat slope in any direction by more than 0.01 rad.

Any bearing areas that exceed these tolerances shall be brought into compliance by grouting or use of shims as directed by the Engineer before the weight of the structure acts on the bearing.

Bearings that have an internal tapered load plates shall be marked with an arrow that points up-station in order to properly align the slope of the internal tapered load plate with the centerline of the bridge.

Sole plates that sit on the bearing shall not be welded to the beam flange in the field unless at least 1.5 in. of the steel exists between the weld and the elastomer. In no case shall the elastomer or the bond be subjected to temperatures higher than 400°F.

No beams shall be erected until the bearings have been accepted by the Engineer.

#### CONTRACTOR QUALITY CONTROL

##### **922.60: General**

The Contractor shall provide a Quality Control System (QC System) to ensure that all materials and workmanship meet the required specifications.

##### **922.61: Quality Control Inspection**

The Contractor shall perform QC inspection of all work items addressed under this specification. Inspection activities during placement may be performed by qualified production personnel. The Contractor's QC personnel shall have overall responsibility for the QC inspection. The Contractor shall not rely on the results of the Engineer's Acceptance inspection for QC purposes. The Engineer shall be provided with the opportunity to monitor and witness all QC inspections.

QC inspection activities must address the following three primary components:

- a. Materials
- b. Environmental Conditions
- c. Workmanship

The minimum frequency of QC inspection activity shall be in accordance with the requirements below.

**Table 922.61-1 - Minimum QC Inspection of Elastomeric Bearing Pads**

<b>Inspection Component</b>	<b>Inspection Attribute</b>	<b>Minimum Inspection Frequency</b>	<b>Point of Inspection</b>	<b>Inspection Method</b>
Materials	Bearing Pad	Each Delivery	Bearing Pad	Check COC
	Geometry and Surface	Each Bearing Pad	Bearing Pad Surface	Visual Check & Check Measurement
Environmental Conditions	Temperature of Air	1 per Day	At Project Site	Check Measurement
Workmanship	Bridge Seat	Each Bearing Location	Bearing Pad Location	Visual Check
	Elevation	Each Bearing Pad	Bearing Pad Location	Check Measurement
	Orientation	Each Bearing Pad	Bearing Pad Location	Check Measurement

**922.62: Quality Control Sampling and Testing Requirements**

The Contractor shall have each Lot of bearing pads sampled and tested in accordance with Subsection M9.14.5G. This shall include both QC and compliant independent laboratory test results.

DEPARTMENT ACCEPTANCE

**922.70: General**

The Department shall sample and test bearing pads as part of its Acceptance activities. Independent testing shall also be used to supplement its testing.

**922.71: Acceptance Inspection**

The Engineer will perform Acceptance inspection to ensure that materials and completed work are in conformance with the contract requirements. Acceptance inspection is intended to visually assess the quality of each Lot produced and placed and will address only the inspection components of materials and workmanship in support of the Department’s final Acceptance determination. All Acceptance inspection activities by the Department will be performed independent of the Contractor’s QC inspection.

**Table 922.71-1 – Department Acceptance Inspection of Elastomeric Bearing Pads**

Inspection Component	Inspection Attribute	Minimum Inspection Frequency	Point of Inspection	Inspection Method
<b>Materials</b>	Bearing Pad	1 Per Bearing Pad	Bearing Pad Surface	Check COC
	Geometry and Surface	1 Per Bearing Pad	Bearing Pad Surface	Visual Check & Check Measurement
<b>Workmanship</b>	Elevation	1 per Bearing Pad	Bearing Pad Location	Check Measurement
	Orientation	1 per Bearing Pad	Bearing Pad Location	Check Measurement

**922.72: Acceptance Sampling and Testing Requirements**

For Acceptance samples taken by the Engineer at the project, the sampling rate shall be in accordance with Subsection M9.14.5G. Bearing pads shall be tested by the Department in accordance with Table M9.14.5-1.

**922.73: Lot Acceptance Determination Based on Inspection Results**

The Engineer’s Acceptance inspection results will be used in the final Acceptance determination for all Lots. Prior to final Acceptance of each Lot produced and placed, the Engineer will evaluate all Acceptance inspection information for the Lot. The materials and product workmanship for the completed work will be evaluated for conformance with the plans and the requirements specified in Subsections 922.60, 922.61, and 922.62.

When the Acceptance information identifies deficiencies in either material quality or product workmanship, the location will be isolated and further evaluated by the Engineer through additional Acceptance inspection. Depending upon the findings of the additional Acceptance inspection activity, the Engineer will determine the disposition of the nonconforming work in accordance with Division I, Subsection 5.03, Conformity with Plans and Specifications.

**922.74: Lot Acceptance Determination Based on Testing Data**

Prior to final Acceptance of each Lot, the Engineer will evaluate all available QC, independent, and Acceptance testing data for the Lot to determine conformance with the minimum requirements in Subsection M9.14.5G and Table M9.14.5-1.

If a test result does not meet the minimum requirement, the Contractor and Engineer will further assess the quality to determine whether the material can remain in place.

If the Engineer’s assessment determines that the material quality is not sufficient to permit the bearing pad to remain in place, the pad shall be removed and replaced. When a nonconforming bearing pad is corrected or replaced, the Engineer will perform Acceptance testing of the replacement bearing pad and evaluate the test results for conformance with the minimum requirements.

**922.75: Final Lot Acceptance Determination**

For each Lot produced and placed, the Engineer will evaluate all Acceptance inspection and testing data for the Lot. The final review and visual inspection shall be conducted jointly by the Contractor and Engineer. Any items that do not meet the requirements of the specifications and plans shall be addressed at this time, at no additional cost to the Department.

After each Lot is complete, including any corrective action, the Engineer will perform a final evaluation of all Acceptance data for the Lot. The Engineer will accept the Lot if the evaluation of all inspection and testing data for the Lot is in conformance with this specification and the contract documents.

When the above requirements have been met, the Engineer will accept all completed bearing pads.

COMPENSATION

**922.80: Method of Measurement**

Laminated Elastomeric Bearing Pads will be measured by each pad installed. Plain Elastomeric Bearing Pads will be measured by the square foot installed. The measured quantities do not include the additional bearings required for conformance and destructive testing.

**922.81: Basis of Payment**

Payment under this item shall be at the contract unit price. This price will include all materials, equipment, tools and labor, additional bearing pads for testing and all required testing necessary to complete the work.

**922.82: Payment Items**

- 921. Laminated Elastomeric Bearing Pad with Anchor Bolts ..... Each
- 922. Laminated Elastomeric Bearing Pad without Anchor Bolts ..... Each
- 923. Laminated Sliding Elastomeric Bearing Pad with Anchor Bolts ..... Each
- 933. Plain Elastomeric Bearing Pad ..... Square Foot

**SECTION 970: DAMP-PROOFING**

Subsection 970.30: General

*Add the following material to this subsection.*

Mortar..... M4.04.0

Subsection 970.40: General

*Replace the second sentence in the second paragraph with the following.*

All holes in concrete surfaces shall be satisfactorily filled with mortar before damp-proofing is applied.

**SUBSECTION 983: REVETMENT**

Subsection 983.64 Special Slope Paving Under Bridges

*Replace the last sentence under B. Quarry Stone or Precast Concrete Blocks. with the following.*

Mortar shall then be placed in the joints to the top of the paved surface.

Subsection 983.65 Channel Paving and Grouted Channel Paving

*Replace the last sentence with the following.*

The grout shall conform to M4.04.0: Grout, Mortar, and Concrete Products.



**DIVISION III**  
**MATERIALS SPECIFICATIONS**

**SECTION M4: CEMENT AND CEMENT CONCRETE MATERIALS**

Subsection M4.02.00 Cement Concrete

Add the following to the end of this subsection.

**Alkali Silica Reactivity - Resistant Portland Cement Concrete**

All cement concrete and precast/prestressed concrete products shall be alkali silica reactivity-resistant. Proportion Portland cement concrete mixes to include materials that meet either the aggregate requirement or Alkali-Silica Reactivity (ASR) mitigation criteria listed below. Provide cement mill test reports from certified laboratories that show the materials' source, composition and the cement alkali content expressed as sodium oxide equivalent(s) not to exceed 1.4%. Certified test reports according to test procedures as specified in Table A will be required to be submitted with the trial batch submission to RMS for approval every year or whenever the source of material is changed.

Select non-reactive aggregates that meet all the criteria of Table M4.02.00-2. Mitigate the mix as described below when nonreactive aggregates are unavailable. If non-reactive aggregates are used for portland cement concrete mix, 15% by weight of the cementitious content shall be fly ash meeting AASHTO M 295, Type F.

Select a material or a combination of materials that meet the criteria shown in Table M4.02.00-3 to mitigate ASR when concrete mixes must be proportioned with reactive aggregates. Perform verification test according to AASHTO T 303 and ASTM C295 to determine the effectiveness of the resulting mix design against ASR. Use the same proportion of cement and pozzolan for each test mixture as that proposed for the actual mix design. Provide the Department with certified documentation of the mixtures' effectiveness to control ASR.

**Table M4.02.00-2: Tests and Criteria for Proposed Aggregates**

Procedure	Description	Limits
AASHTO T 303: Accelerated Detection of Potentially Deleterious Expansion of Mortar Bars Due to Alkali-Silica Reaction	Mean mortar bar expansion at 14 days. Perform a polynomial fit <sup>(1)</sup> of 4, 7, 11, and 14 days to determine reliability of results	0.08% maximum metamorphic aggregate; 0.10% maximum all other aggregates. Repeat AASHTO T 303 if r <sup>2</sup> is less than 0.95.
ASTM C295: Petrographic Examination of Aggregates for Concrete	Optically strained, microfractured, or microcrystalline quartz	5.0% maximum <sup>(2)</sup>
	Chert or chalcedony	3.0% maximum <sup>(2)</sup>
	Tridymite or cristobolite	1.0% maximum <sup>(2)</sup>
	Opal	0.5% maximum <sup>(2)</sup>
	Natural volcanic glass	3.0% maximum <sup>(2)</sup>
<sup>(1)</sup> Use a second order polynomial of %Exp = A <sup>0</sup> + A <sup>1</sup> SQRT(t) + A <sup>2</sup> t. See publication SD92-04-F. <sup>(2)</sup> Based on the total aggregate sample.		

**Table M4.02.00-3: Mitigation Methods for ASR in Portland Cement Concrete**

Material	Specification	Cementitious Material Percentage <sup>(1)</sup>
Low alkali cement <sup>(2)</sup>	AASHTO M 85	100%
Fly ash - Class F	AASHTO M 295	15% minimum to 30% <sup>(4)</sup> maximum
Silica Fume <sup>(5)</sup>	AASHTO M 307	6% ± 1% <sup>(6)</sup>
Slag Grade 100 and 120	AASHTO M 302	25% minimum to 50% maximum

<sup>(1)</sup> Measure this minimum content of cementitious material as percent by weight of cement plus pozzolan.

<sup>(2)</sup> This single criterion is not effective in all cases in remediating ASR. Low alkali cement (0.60% maximum <sup>(3)</sup>) must be used in combination with other pozzolanic materials in Table B.

<sup>(3)</sup> Na<sub>2</sub>O equivalent = %Na<sub>2</sub>O + 0.658 (%K<sub>2</sub>O)

<sup>(4)</sup> Fly ash, Type F, shall replace 15% by weight of the design cement content, and any additional fly ash will be considered as fine aggregate.

<sup>(5)</sup> Silica fume shall only be used in silica fume cement concrete.

<sup>(6)</sup> The total amount of Type F fly ash and silica fume shall constitute 20% by weight of the design cement content, and any additional fly ash shall be considered as fine aggregate.

#### Subsection M4.02.15 Cement Mortar

Delete this subsection.

#### Subsection M4.04.0: Grout, Mortar and Concrete Products

Replace this subsection with the following.

#### **M4.04.0: Grout, Mortar, and Concrete Products**

Grout, cementitious mortar, and concrete products shall be packaged, dry, and preblended with preformulated constituent materials (excluding mixing water) to produce a material with acceptable quality characteristics and material properties, including time of set, compressive strength, flexural strength, slant shear bond strength, resistance to alkali silica reaction, freezing/thawing, and de-icing cycles, shrinkage, expansion, and sulfate reaction.

Mortar products shall be defined as products containing aggregate of which less than 5% by mass of the total mixture is retained on the 3/8 in. sieve. Mortar products for concrete repairs shall be used only on repair depths of 2 in. or less. Concrete products shall be defined as products containing aggregate of which 5% or more by mass of the total mixture is retained on the 3/8 in. sieve. Concrete products for concrete repairs shall be used only on repair depths greater than 2 in.

The aggregate sources included in the prepackaged product or extended into the product shall meet Section M4.02.02: Aggregates. Grout, cementitious mortar, and concrete products shall only be applied per the requirements provided on the product's technical data sheet. Grout, cementitious mortar, and concrete products shall maintain valid listing on the MassDOT Qualified Construction Materials List (QCML). Grout, cementitious mortar, and concrete products shall meet requirements specified herein.

##### **A. Technical Data Sheet.**

The Manufacturer shall submit the product's technical data sheet to the Department for review. At a minimum, the product's technical data sheets shall include:

- (a) Product Name
- (b) Manufacturer, including address and contact information
- (c) Packaging
- (d) Yield
- (e) Product Description, including an overview of the product and its intended application(s) and use(s).

- (f) Technical Data, including quality characteristics and corresponding performance criteria with the AASHTO and/or ASTM standard test methods identified.
- (g) Recommended Equipment
- (h) Instructions, including surface preparation, mixing, forming, placing, finishing, curing, and protection from adverse conditions, such as precipitation, cold conditions, and hot conditions.
- (i) Limitations
- (j) Storage and Shelf Life
- (k) Safety

**B. Mix Design Formulation.**

Products that are extended with aggregate not included in the original product packaging shall be formulated per the product's technical data sheet and evaluated through Department mix design evaluation and verification testing. Producers shall report and submit proposed mix design formulations onto the Department issued mix design sheet. The Producer shall select an AASHTO accredited independent laboratory to conduct verification testing. The sampling and testing conducted by the independent laboratory shall be witnessed by the Department.

**C. Product Verification Testing.**

Verification test results shall be within the limits specified herein.

**M4.04.1: Conventional Grout, Cementitious Mortar, and Concrete Products**

Conventional grout, cementitious mortar, and concrete products shall meet the requirements of Section M4: Cement and Cement Concrete Materials, performance criteria of the product's technical data sheet, and the requirements specified herein.

**M4.04.2: Rapid Hardening Cementitious Mortar and Concrete Products**

Rapid hardening cementitious mortar and concrete products shall meet the requirements and performance criteria of the product's technical data sheet, ASTM C928 Standard Specification for Packaged, Dry, Rapid-Hardening Cementitious Materials for Concrete Repairs, and Table M4.04.2-2.

***Table M4.04.2-1: Types of Rapid Hardening Cementitious Products for Concrete Repairs***

<b>Type</b>	<b>Description</b>	<b>Application</b>
R1	General Rapid Hardening	Vertical and Overhead Repairs
R2	Medium Rapid Hardening	Vertical and Overhead Repairs
R3	Very Rapid Hardening	Horizontal, Vertical, and Overhead Repairs

**Table M4.04.2-2: Verification Testing Requirements**

Property	Method	Quality Characteristic		Limits					
				R1		R2		R3	
				Min.	Max.	Min.	Max.	Min.	Max.
Setting	T 197	Initial Set (min.)		Technical Data Sheet					
		Final Set (min.)		Technical Data Sheet					
Strength	T 97 <sup>[1]</sup>	Flexural Strength (psi)	24 Hours	-	-	-	-	650	-
			7 Days	-	-	-	-	-	-
Durability	T 358	Surface Chloride Ion Penetration Resistance (kΩ-cm)	28 Days	21	-	21	-	21	-
			T 161 (A)	Relative Durability Factor		90	-	90	-
		Mass Loss (%)		-	6.0	-	6.0	-	6.0

[1] Not applicable to vertical and overhead repair applications.

**M4.04.3: Mortar Products for Unit Masonry**

Mortar products for unit masonry shall meet the requirements and performance criteria of the product’s technical data sheet and Type M specified in ASTM C270 Standard Specification for Mortar for Unit Masonry. Field proportioned cement mortar for laying brick and block shall be composed of 1 part Portland cement and 2 parts of fine aggregate by volume with a sufficient amount of water to form a workable mixture, while still achieving the properties specified herein.

**M4.04.4: Grout Products for Unit Masonry**

Grout products for unit masonry shall meet the requirements and performance criteria of the product’s technical data sheet and ASTM C476 Standard Specification for Grout for Masonry.

**M4.04.5: Non-Shrink Grout Products**

Non-shrink grout products are intended for use under applied load, including supporting a structure, transfer medium between load-bearing members, shear keys, and other non-shrink applications, where a change in height below initial placement height is to be avoided. Non-shrink grout products shall meet the requirements and performance criteria of the product’s technical data sheet and ASTM C1107 Standard Specification for Packaged Dry, Hydraulic-Cement Grout (Nonshrink).

**SECTION M5: PIPE, CULVERT SECTIONS AND CONDUIT**

Subsection M5.01.0: Joint Material for Pipe

Replace M4.02.15 Cement Mortar with M4.04.0 Grout, Mortar, and Concrete Products in paragraph B.

**SECTION M8: METALS AND RELATED MATERIALS**

Subsection M8.18.1: Traffic Signal Supports

Delete the heading Posts and the two paragraphs under it. Delete the heading Bases and the three paragraphs under it.

**SECTION M9: MISCELLANEOUS MATERIALS**

Subsection M9.14.5: Elastomeric Bridge Bearing Pads

Replace this subsection with the following:

---

**M9.14.5: Elastomeric Bearing Pads****A. General Requirements**

Elastomeric bearing pads shall be plain or laminated. They shall meet the applicable requirements of AASHTO M 251, the MassDOT Bridge Manual, and the AASHTO LRFD Bridge Design and Construction Specifications. The type of bearing will be specified on the plans.

Laminated elastomeric bearing pads consist of layers of elastomers restrained at their interfaces by bonded metal laminates.

**B. Material Requirements**

Plain elastomeric bearing pads shall consist of elastomer.

Laminated elastomeric bearing pad shall consist of:

- Elastomer
- Internal Steel Laminates
- Tapered Internal Load Plates (if used)

The components of the elastomeric bearing pad shall conform to AASHTO M 251 and the following:

- The elastomer compound shall be 100% virgin neoprene and classified as being of low-temperature grade 3.
- The steel laminates shall meet the requirements of ASTM A 1011 Grade 36 or higher

**C. Material Qualification**

Elastomeric bearing pads shall be approved on a project basis. The Contractor shall furnish to the Research and Materials Section certified independent test reports demonstrating conformance. All testing shall be performed by the same independent lab in accordance with Subsection M9.14.5G.

**D. Fabricators**

Bearing shall be fabricated by a fabricator listed on the MassDOT Qualified Construction Materials List (QCML).

**E. Fabrication**

Fabrication shall not begin until the shop drawings have been approved and the Department has an inspector at the fabricator's facility.

The shop drawings shall specify bearing dimensions as shown on the plans and, where applicable, shall include:

- Elastomer thickness and edge cover,
- Number and thickness of steel reinforcing laminates,
- Dimensions of load plates (if any),
- Design shear modulus of the elastomer shall be as shown on the Plans.

Plain elastomeric bearing pads shall be fabricated and tested in accordance with the "Method A" design outlined in the AASHTO LRFD Bridge Design Specifications.

Laminated elastomeric bearing pads shall be fabricated and tested in accordance with the "Method B" design outlined in the AASHTO LRFD Bridge Design Specifications.

The manufacturer shall designate the bearings in each Lot, as described in Subsection M9.14.5G, and certify that each bearing in the Lot was manufactured in a reasonably continuous manner from the same batch of elastomer and cured under the same conditions. In addition, the manufacturer shall certify that each bearing in the Lot satisfies the requirements of this specification, AASHTO M 251, the AASHTO LRFD Bridge Construction Specifications, and the contract plans and documents.

The tolerances on the overall dimensions for the bearings shall be according to Table 2 of AASHTO M 251, except that the tolerance on the overall vertical dimension shall be limited to 0, +1/8" regardless of the design thickness.

All steel included in the final bearing product must conform to Buy America Requirements.

#### **F. Packaging, Handling, & Storage**

The bearing pads shall be packaged, handled, and stored as specified below:

Prior to shipment from the point of manufacture, bearings shall be packaged in such a manner to ensure that during shipment and storage the bearings will be protected against damage from handling, weather, or any normal hazard. Each completed bearing shall have its components clearly identified, be securely bolted, strapped, or otherwise fastened to prevent any relative movement, and be marked on its top as to location and orientation in each structure in the project in conformity with the contract documents.

Each elastomeric bearing shall be marked in indelible ink or flexible paint. The marking shall consist of the order number, lot number, bearing identification number, and elastomer type and grade per AASHTO M 251. For bearing pads fabricated with a tapered internal load plate, a 1/32" deep direction arrow shall be inscribed into the bearing which will allow the bearing to be aligned with the up-station direction. All marks shall be permanent and be visible after the bearing is installed.

#### **G. Testing Requirements**

##### **Quality Control System**

Fabricators shall perform Quality Control (QC) testing in accordance with their quality system. QC test reports shall accompany the bearing pads when delivered to the project.

##### **Acceptance System**

MassDOT will evaluate the fabricator's quality system and QC test reports. It will also perform its own testing and verify the independent laboratory's test reports, if applicable.

##### **Lot Sizes**

Sampling of bearing pads for testing shall be random and performed on a Lot basis. A Lot of bearings shall be a group of 100 or fewer bearings that are:

- For a single contract,
- Cured under the same conditions,
- The same size and configuration,
- Manufactured in a reasonably continuous manner from the same batch of elastomer.

##### **Testing of Plain Bearings**

###### **Testing Laboratory**

Plain elastomeric bearing pads shall be tested by both an independent laboratory and MassDOT:

- Independent testing shall be performed by a nationally recognized third-party laboratory approved by the Research & Materials Section.
- Acceptance testing shall be performed by the Research and Materials.

###### **Sampling Frequency**

Each Lot of plain bearings shall be randomly sampled for testing. The Contractor shall ensure that the fabricator produces the additional bearings required for testing.

Samples for independent testing shall be selected by the fabricator. The sampling rate for the independent

testing shall be as follows:

- Lot sizes less than 10 bearings – One full-size bearing per Lot.
- Lot sizes greater than or equal to 10 bearings – Two full-size bearings per lot.

Samples for Acceptance testing shall be selected by the Engineer. The sampling rate for Acceptance testing shall be one bearing pad per lot.

### ***Testing Requirements***

The laboratory shall test the bearings in accordance with Sections 8 and 9 of AASHTO M 251 as specified below:

1. Dimensions per Section 8.4.
2. Elastomer per Section 8.6.
  - The hardness, tensile strength, and ultimate elongation shall be in accordance with Table 1 of AASHTO M 251.
3. Test procedures per Section 8.9.
  - Heat resistance per Section 8.9.3.

### **Testing of Laminated Bearings**

#### ***Testing Laboratory***

Laminated elastomeric bearing pads shall be tested by both an independent laboratory and MassDOT:

- Independent testing shall be performed by a nationally recognized third-party laboratory approved by the Research & Materials Section.
- Acceptance testing shall be performed by the Research and Materials.

#### ***Sampling Frequency***

Each Lot of laminated bearings shall be randomly sampled for testing. The Contractor shall ensure that the fabricator produces the additional bearings required for testing.

Samples for independent testing shall be selected by the fabricator. The sampling rate for the independent testing shall be as follows:

- Lot sizes less than 10 bearings – One full-size bearing per Lot.
- Lots sizes greater than or equal to 10 bearings:
  - One full-size bearing per every twenty per lot, or a minimum of two bearings.
  - The number of laminated bearings to sample shall be determined by taking the Lot size divided by 20. If the integer part of this calculation is 0 or 1, then two bearings shall be sampled. For example, if the lot size is 58 laminated bearings, two bearings shall be sampled; if the lot size is 65, three bearings shall be sampled; and if the lot size is 22, two bearings shall be sampled.

Samples for Acceptance testing shall be selected by the Engineer. The sampling rate for Acceptance testing shall be one bearing pad per lot.

### ***Testing Requirements***

Testing of the bearings shall be in accordance with Sections 8 and 9 of AASHTO M 251 as specified below:

1. Dimensions per Section 8.4.
2. Elastomer per Section 8.6.
  - The hardness, tensile strength, and ultimate elongation shall be in accordance with Table 1 of AASHTO M 251.
3. Compressive strain at the maximum design dead plus live service compressive load per Section 8.8.1.1.

- The compressive deflection, as determined per Section 9.1., between the two loadings for each bearing tested shall not exceed 10%.
- 4. Bond via Compressive Load per Section 8.8.2.2.
- 5. Shear Modulus of the elastomer per Section 8.8.3.
  - Shear modulus shall meet the requirements on the plans.
- 6. Test procedures per Section 8.9.
  - a. Additional Low Temperature Shear Modulus testing per Section 8.9.1.
  - b. Heat resistance per Section 8.9.3.
  - c. Compression set per Section 8.9.4.
  - d. Creep per Section 8.9.5.
    - The percent creep shall be less than 35%.
  - e. Long Term Compression per Section 8.9.6.

**Table M9.14.5-1: Department Acceptance Testing of Elastomeric Bearing Pads**

Quality Characteristic	Test Method	Requirement
Hardness	ASTM D2240	From Independent Test Results ± 5 Pts
Tensile Strength	ASTM D412	≥ 2250 psi
Ultimate Elongation	ASTM D412	Minimum Elongation Based on Durometer according to AASHTO M 251 Table 1
Shear Modulus (see Note 1)	ASTM D4014	Specified Value ± 15%
<b>After Heat Aging for 70 Hours at 100°C (Maximum Change from Unaged Testing)</b>		
Hardness	ASTM D573	Hardness + 15 Pts
Tensile Strength	ASTM D573	Tensile Strength - 15%
Ultimate Elongation	ASTM D573	Ultimate Elongation - 40%
Note 1: Test is only required for laminated elastomeric bearing pads.		

## SECTION M10: TRAFFIC CONTROL DEVICES

### Subsection M10.05.0: Traffic Signal Structures (General)

*Add this new subsection.*

#### **M10.05.0: Traffic Signal Structures (General)**

The bases of all Traffic Signal Structures shall be supplied with a bonding lug.

### Subsection M10.05.1: Signal Posts and Bases

*Add this new subsection.*

#### **M10.05.1: Signal Posts and Bases**

All Signal Posts shall be one-piece 4-in. diameter, Schedule 40 or Schedule 80, and machine-threaded.

Signal Posts may be fabricated from aluminum with a brushed or spun finish or from steel with a galvanized finish.

The interior of Signal Posts shall be coated as specified in Underwriters Laboratories UL-6 for enameled conduit, or aluminum conduit conforming to M5.07.1: Electrical Conduit-Rigid Metallic (Type RM), Paragraph C.

Signal Posts Bases shall be fabricated to accept the threads from the Signal Post and locked into place with set screws.





THIS PAGE IS INTENTIONALLY LEFT BLANK

## DOCUMENT 00718

SPECIAL PROVISION FOR PARTICIPATION BY MINORITY OR WOMEN'S BUSINESS ENTERPRISES  
AND SERVICE- DISABLED VETERAN- OWNED BUSINESS ENTERPRISES

(Implementing Chapter 102, Section 24 and  
Chapter 273, Section 124, of the Acts of 1994 and Chapter 56, Sections 1 to 5 of the Acts of 2010  
and subsequent Acts)

Revised: September 27, 2021

## I. PARTICIPATION

## M/WBE PARTICIPATION GOAL

On this Contract, the Massachusetts Department of Transportation (MassDOT) has established a goal for participation by Minority or Women Business Enterprise(s) (M/WBE). One half of the goal shall be met in the form of contractor activity. This goal shall remain in effect throughout the life of the Contract.

Design-Bid-Build Projects: M/WBE Participation Goal   5  %  
(One half of this goal shall be met in the form of Subcontractor construction activity)

Design-Build Projects: M/WBE Design Participation Goal   % and M/WBE  
Construction Participation Goal   %  
(One half of the Construction Goal shall be met in the form of Subcontractor  
construction activity)

## SDVOBE PARTICIPATION BENCHMARK

On this Contract, the Massachusetts Department of Transportation (MassDOT) has established a goal for participation by Service- Disabled Veteran- Owned Business Enterprise(s) (SDVOBE). This goal shall remain in effect throughout the life of the Contract.

Design-Bid-Build Projects: SDVOBE Participation Goal   %

Design-Build Projects: SDVOBE Design Participation Goal   % and SDVOBE  
Construction Participation Goal   %

## II. POLICY

It is the policy of the MassDOT that Minority, Women Business Enterprises (M/WBEs) and Service- Disabled Veteran- Owned Business Enterprises (SDVOBEs) have equal opportunity to receive and participate in the performance of its state funded Contracts.

## III. M/WBE and SDVOBE OBLIGATION

The Contractor agrees to take all necessary and reasonable steps to ensure that MBE, WBE, and SDVOBEs have the maximum opportunity to compete for, and to perform, Department Contracts.

## IV. FAILURE TO COMPLY WITH M/WBE OR SDVOBE REQUIREMENTS

All Contractors and Subcontractors are hereby advised that failure to carry out the requirements of these Provisions constitutes a breach of Contract which may result in termination of the Contract, a determination that the Contractor or Subcontractor be barred from bidding on Department Contracts for up to three (3) years, or any other remedy as the Department may impose under Section XIV of these Special Provisions.

## V. REQUIRED SUBCONTRACT PROVISIONS

The Prime Contractor shall include the Provisions of Sections II, III, and IV above in every subcontract making those provisions binding on each subcontractor, supplier, manufacturer, consultant or service provider.

## VI. DEFINITIONS

For the purpose of these Special Provisions, the terms listed below are defined as follows:

Minority Business Enterprise or MBE means any individual, business organization, or non-profit corporation certified as a MBE by the Supplier Diversity Office (SDO), formerly known as the State Office of Minority and Women Business Assistance (SOMWBA), or by the Department for the purposes of a particular bid or proposal to be submitted to the Department.

Women Business Enterprise or WBE means any individual, business or organization, or non-profit corporation certified as a WBE by SDO, or by the Department for the purposes of a particular bid or proposal to be submitted to the Department.

Service- Disabled Veterans- Owned Businesses or SDVOBE means a business not less than 51 percent of which is owned by one or more service- disabled veterans or, in the case of any publicly owned business, not less than 51 percent of the stock of which is owned by one or more service-disabled veterans; and the management and daily business operations of which are controlled by one or more service- disabled veterans or, in the case of a veteran with permanent and severe disability, the spouse or permanent caregiver of such veteran.

"Contractor activity" means any work, including but not limited to, construction, demolition, renovation, survey, test boring services, or maintenance work performed under the Contract.

"Approved Joint Venture" means a joint venture between M/WBEs and non-M/WBEs, or SDVOBEs and non-SDVOBEs, which has been established for the purpose of participation on a particular contract, where:

1. The M/WBE or SDVOBE partner(s) shares in the ownership, control, management responsibilities, risks and profits of the joint venture; and
2. The Joint Venture has been approved by the Department for M/WBE or SDVOBE participation on the particular contract.

"Equipment Rental Firm" means a firm that owns equipment and assumes actual and contractual responsibility to rent said equipment to perform a useful function of the work of the contract consistent with normal industry practice.

"Material Supplier" means a vendor engaged in sales to the highway construction industry from an established place of business or source of supply, which:

- (a) Manufactures goods from raw materials or substantially alters them before resale, or
- (b) Provides and maintains a storage facility for materials used in the work, consistent with normal industry practice.

"Department" means the Massachusetts Department of Transportation (MassDOT).

"SDO" means the Massachusetts Supplier Diversity Office.

---

## VII. ELIGIBILITY of M/WBEs

Only firms, *OTHER THAN THE PRIME CONTRACTOR*, which have been certified by SDO and/or the Department as eligible to participate on state funded contracts as MBEs or WBEs may be used on this contract for credit toward the toward the M/WBE participation goal.

1. SDO Directory of Certified M/WBEs: The Supplier Diversity Office publishes a Directory of certified MBE and WBEs. This Directory can be obtained from SDO at <https://www.sdo.osd.state.ma.us/>. This site lists those firms which have been certified as minority owned (MBEs) or women owned (WBEs) in accordance with the criteria of 425 CMR 2.00 et seq to participate as M/WBEs on state funded contracts. It also lists the kinds of work in which each firm engages but does not constitute an endorsement of the quality or performance of any business and does not represent Department subcontractor approval.
2. Application for Certification by the Department for a Particular Project: A firm which has (1) submitted a fully completed M/WBE application to SDO at least 30 days previously, (2) has provided in a timely manner, any additional information which may have been requested by SDO, and (3) can provide evidence, satisfactory to the Department, of a bidder's conditional commitment to subcontract with the firm, if certified, may apply directly to the MassDOT Office of Civil Rights to be certified for participation on the particular contract.
3. Joint Venture Approval: To obtain recognition as an approved joint venture between M/WBEs and non-M/WBEs, the Joint Venture must provide to the MassDOT Office of Civil Rights, at least 14 business days before the bid opening date, the Joint Venture Affidavit Document B00847, and a copy of the Joint Venture Agreement, which shall include a detailed breakdown of the following:
  - (a) Capital participation by the M/WBE,
  - (b) Specific equipment to be provided to the Joint Venture by the M/WBE,
  - (c) Specific responsibilities of the M/WBE in the management of the Joint Venture,
  - (d) Workforce and specific skills to be provided to the Joint Venture by the M/WBE, and
  - (e) Percentage distribution to the M/WBE of the projected profit or loss incurred by the Joint Venture.
  - (f) The Joint Venture shall provide all such additional information as may be requested by the Department for the purpose of determining joint venture eligibility.

## VIII. ELIGIBILITY of SDVOBEs

Only firms, *OTHER THAN THE PRIME CONTRACTOR*, which have demonstrated that they are listed as a service-disabled veteran- owned small businesses within the VetBiz database may be used on this contract for credit toward the SDVOBE participation goal.

1. VetBiz Database: The website, located at [www.VetBiz.gov](http://www.VetBiz.gov), listing verified service- disabled veteran- owned businesses.
2. Joint Venture Approval: To obtain recognition as an approved joint venture between SDVOBEs and non-SDVOBEs, the joint venture must provide to the MassDOT Office of Civil Rights, at least 14 business days before the bid opening date, an application for joint venture participation approval, and a copy of the Joint Venture Agreement, which shall include a detailed breakdown of the following:
  - (a) Capital participation by the SDVOBE,
  - (b) Specific equipment to be provided to the joint venture by the SDVOBE,
  - (c) Specific responsibilities of the SDVOBE in the management of the Joint Venture,
  - (d) Workforce and specific skills to be provided to the joint venture by the SDVOBE, and

- (e) Percentage distribution to the SDVOBE of the projected profit or loss incurred by the Joint Venture.
- (f) The Joint Venture shall provide all such additional information as may be requested by the Department for the purpose of determining joint venture eligibility.

#### IX. COUNTING M/WBE PARTICIPATION AND SDVOBE BENCHMARKS TOWARDS M/WBE AND SDVOBE GOALS

In order for M/WBE participation and SDVOBE benchmarks to count toward the Contract goal, the M/WBE and SDVOBE must have independently managed, supervised and performed the Contract work with its own workforce, equipment and resources. M/WBE and SDVOBE participation which fulfills these requirements shall be counted toward meeting the M/WBE and SDVOBE goals in accordance with the following rules:

1. If a firm has been determined to be an eligible MBE, WBE or SDVOBE, the total dollar value of the contract performed by the M/WBE or SDVOBE is counted toward the applicable goal as follows:
  - a. Except as provided below, in Section IX (1)(g), work performed by a M/WBE or a SDVOBE Prime Contractor shall not be counted toward the M/WBE or SDVOBE goal, and all Prime Contractors, including M/WBE or SDVOBE Prime Contractors, must comply with the M/WBE and SDVOBE requirements of this Contract.
  - b. For a M/WBE or SDVOBE material supplier, sixty percent (60%) of the amount to be paid for materials and supplies required under this Contract shall be credited toward the goal.
  - c. For a M/WBE or SDVOBE who provides a bonafide service such as professional, technical, consultant or managerial services and assistance in the procurement of essential personnel, facilities, equipment, materials, or supplies required for performance of the contract, reasonable fees or commissions charged for the service shall be listed, but the cost of items themselves shall not be credited.
  - d. For a M/WBE or SDVOBE hauler, trucker, or delivery service, which is not also the manufacturer of or a regular dealer in the materials and supplies, reasonable fees charged for delivery of materials and supplies required on the job site shall be credited; the cost of the materials and supplies themselves shall not be credited.
  - e. For a M/WBE or SDVOBE who provides any bonds or insurance specifically required for the performance of the contract, reasonable fees or commissions charged for such service shall be listed, but the face amount or actual premium paid for the bond or insurance shall not be credited.
  - f. The Department shall determine if the fees or commissions listed in accordance with paragraphs (c), (d), and (e) are not excessive as compared with fees or commissions customarily allowed for similar services.
  - g. That portion of the contract total dollar value equal to the percentage of ownership and control of the M/WBE partner(s) or SDVOBE partner(s) in an approved Joint Venture shall be counted toward the Contract goal, except that credit for M/WBE and SDVOBE participation in an approved Prime Joint Venture shall not exceed one half of the Contract goal.

#### X. JOINT CHECK POLICY

1. MassDOT recognizes that the use of joint checks may be a business practice required by material suppliers and vendors in the construction industry. A joint check is a two-party check issued by a/the Prime Contractor to a M/WBE or SDVOBE third party such as a regular dealer of material or supplies. The Prime Contractor issues the check as payor to the M/WBE or SDVOBE and the third party jointly as payees to guarantee payment to the third party for materials or supplies obtained or to be used by the M/WBE or SDVOBE. MassDOT has established criteria to ensure that M/WBEs or SDVOBEs are in fact performing a commercially useful function ("CUF") while using a joint check arrangement. Contractors and M/WBEs or SDVOBEs must meet and conform to these conditions and criteria governing the use of joint checks.

2. In the event that a Contractor, M/WBE or SDVOBE Subcontractor desires to use a joint check, MassDOT will require prior notice and will closely monitor the arrangement for compliance. MassDOT may allow a joint check arrangement and give credit to a Contractor for use of the M/WBE or SDVOBE where one or more of the following conditions exist:
  - The use of a joint check is in fact required by this type of vendor or supplier as a standard industry practice that applies to all Contractors (M/WBEs, SDVOBE and non-M/WBEs or non-SDVOBEs); or is required by a specific vendor or supplier;
  - Payment for supplies or materials would be delayed for an unreasonably extended period without the joint check arrangement;
  - The M/WBE or SDVOBE (or any of its Subcontractors) has a pattern or history of not paying a vendor or supplier within a reasonable time or has not established enough of a credit history with the supplier or vendor; and/or
  - The presence of severe adverse economic conditions, where credit resources may be limited and such practices may be necessary or required to effect timely payments.
3. Other factors MassDOT may consider:
  - Whether there is a requirement by the Prime Contractor that a M/WBE or SDVOBE should use a specific vendor or supplier to meet their Subcontractor specifications;
  - Whether there is a requirement that a M/WBE or SDVOBE use the Prime Contractor's negotiated price;
  - The independence of the M/WBE or SDVOBE;
  - Whether approval has been sought prior to use of a joint check arrangement; and
  - Whether any approved joint check arrangement has exceeded a reasonable period of use;
  - The operation of the joint check arrangement; and
  - Whether the M/WBE or SDVOBE has made an effort to establish alternate arrangements for following periods ( i.e., the M/WBE or SDVOBE must show it can, or has, or why it has not, established or increased a credit line with the vendor or supplier).

Even with the use of a Joint Check, both the Contractor and M/WBE or SDVOBE remain responsible for compliance with all other elements of the Special Provisions, and must still be able to prove that a commercially useful function is being performed for the Contractor.

#### XI. JOINT CHECK PROCEDURES

- The M/WBE or SDVOBE advises its General or Prime Contractor that it will have to use a Joint Check and provide proof of such requirement.
- The General or the Prime Contractor submits a request for approval to MassDOT, using MassDOT's approved Joint Check Request form (Document B00846) and by notification on the M/WBE Letter of Intent (Document B00843) or SDVOBE Letter of Intent (Document B00845), and any other relevant documents. Requests that are not initiated during the bid process should be made in writing and comply with the procedure.
- The Contractor and M/WBE or SDVOBE must have:
  - (a) a written agreement with the material supplier/vendor;
  - (b) applied for credit with the subject material supplier and has supplied the vendor's response;

- (c) shown that it will place all orders to the subject material supplier/vendor;
  - (d) made and retains all decision-making responsibilities concerning the materials; and
  - (e) provided a Joint Check Agreement that is acceptable to MassDOT;
- The MassDOT Office of Civil Rights will review the request and render a decision as part of the approval process for M/WBE or SDVOBE Schedules and Letters of Intent.
  - Review and Approval will be project specific and relevant documents will be made part of the Project Contract file.
  - Payments should be made in the name of both the M/WBE or SDVOBE and vendor or supplier. Payments should be issued and signed by the Contractor as only the guarantor for prompt payment of purchases to the vendor or supplier. The payment to the vendor or supplier should be handled by the M/WBE or SDVOBE (i.e. if possible, funds or the joint check should be processed by the M/WBE or SDVOBE and sent by the M/WBE or SDVOBE to the vendor or supplier).
  - MassDOT may request copies of cancelled checks (front and back) and transmittal information to verify any payments made to the M/WBE or SDVOBE and vendor or supplier.
  - MassDOT may request other information and documents, and may ask questions of the Contractor, Subcontractor and vendor or supplier prior to, during, and after the project performance to ascertain whether the Subcontractor is performing a commercially useful function and all parties are complying with M/WBE or SDVOBE Program policies and procedures as part of the Subcontractor approval process.

## XII. AWARD DOCUMENTATION AND PROCEDURES

1. The two lowest bidders/the two bidders with the lowest price per quality score point, including any M/WBE bidder or SDVOBE bidder, shall submit, by the close of business on the third business day after the bid opening, a completed Schedule of M/WBE and SDVOBE participation, in the form attached, which shall list:
  - a. The full company name, address and telephone number of each M/WBE or SDVOBE with whom the bidder intends to make a commitment;
  - b. The Contract item(s), by number(s) and quantity(ies), if applicable, or specific description of other business activity to be performed by each M/WBE or SDVOBE as set forth in the Letters of Intent. The bidder shall list only firms which have the capacity to perform, manage and supervise the work proposed in accordance with the requirements of Section XII of these Special Provisions.
  - c. The total dollar amount to be paid to each M/WBE or SDVOBE. (Bidders are cautioned that at least one half of the participation goal must be met with Contract work.)
  - d. The total dollar amount to be paid to each M/WBE or SDVOBE which is eligible for credit toward the M/WBE or SDVOBE goal under the crediting rules set out in Section IX.
  - e. The total creditable M/WBE or SDVOBE participation as a percentage of the total bid price.
2. All firms listed on the Schedule must be currently certified.
3. The two lowest bidders/the two bidders with the lowest price per quality score point shall submit with their Schedules of Participation, fully completed, signed Letters of Intent from each of the M/WBEs or SDVOBEs listed on the Schedule. The Letters of Intent shall be in the form attached and shall identify specifically the contract activity the M/WBE or SDVOBE proposes to perform, expressed as contract item number, if applicable, description of the activity, quantity, unit price and total price. In the event of discrepancy between the Schedule and the Letter of Intent, the Letter of Intent shall govern.



4. Evidence of good faith efforts will be evaluated by the Department in the selection of the lowest responsible bidder/best value bidder. All information requested by the Department for the purpose of evaluating the bidder's efforts to achieve the goal must be provided within three calendar days and must be accurate and complete in every detail. The apparent low bidder's/best value bidder's attainment of the M/WBE or SDVOBE goal or a satisfactory demonstration of good faith efforts is a prerequisite for Award of the Contract.
5. Failure to meet, or to demonstrate good faith efforts to meet, the requirements of these Special Provisions shall render a bid non-responsive. Therefore, in order to be eligible for award, the bidder (1) must list on the Schedule of Participation, and provide the required Letters of Intent for, M/WBE or SDVOBE participation which meets or exceeds the Contract goal in accordance with the terms of these Special Provisions or (2) must demonstrate, to the satisfaction of the Department, that good faith efforts were made to achieve the goal.
6. If the Department finds that the percentage of M/WBE or SDVOBE participation submitted by the bidder on its Schedule does not meet the Contract goal, or that the Letters of Intent were not timely filed, and that the bidder has not demonstrated good faith efforts to comply with these requirements, it shall propose that the bidder be declared ineligible for Award. In that case, the bidder may request administrative reconsideration. Such requests must be sent in writing within three calendar days of receiving notice of proposed ineligibility to: The Office of the General Counsel, Massachusetts Department of Transportation, 10 Park Plaza, Boston, MA, 02116.
7. If, after administrative reconsideration, the Department finds that the bidder has not shown that sufficient good faith efforts were made to comply with the requirements of these Special Provisions it shall reject the bidder's proposal and may retain the proposal guaranty.
8. Actions which constitute evidence of good faith efforts to meet the M/WBE or SDVOBE goals include, but are not limited to, all of the following examples:
  - a. Efforts made to select portions of the work proposed to be performed by M/WBEs or SDVOBEs in order to increase the likelihood of achieving the stated goal, including, where appropriate, but not limited to, breaking down contracts into economically feasible units to facilitate M/WBE and SDVOBE participation. The value of such work is required to at least equal the M/WBE and SDVOBE goal.
  - b. Reasonable written notification prior to the opening of bids soliciting individual M/WBEs or SDVOBEs interested in participation in the contract as subcontractors, regular dealers, manufacturers, consultants, or service providers and identifying the specific items or type of work being solicited.
  - c. Written notification to M/WBE or SDVOBE economic development assistance agencies and organizations which provide assistance in recruitment and placement of M/WBEs and SDVOBEs, describing the type of work, supplies or services being considered for M/WBE or SDVOBE subcontracting on this contract.
  - d. Efforts made to negotiate with M/WBEs or SDVOBEs for specific items of work including evidence of:
    - (1) The names, addresses, telephone numbers of M/WBEs or SDVOBEs who were contacted, the dates of initial contact and whether initial solicitations of interest were followed up by contacts with M/WBEs or SDVOBEs to determine with certainty whether the M/WBEs or SDVOBEs were interested. Personal or phone contacts are expected.
    - (2) A description of the information provided by the M/WBEs or SDVOBEs regarding the plans and specifications and estimated quantities for portions of the work to be performed.
    - (3) A statement of why additional agreements with M/WBEs or SDVOBEs were not reached.
    - (4) Documentation of each M/WBE or SDVOBE contacted but rejected and the reasons for the rejection.
  - e. Absence of any agreements between the Contractor and the M/WBE or SDVOBE in which M/WBE or SDVOBE promises not to provide subcontracting quotations to other bidders.
  - f. Efforts made to assist the M/WBEs or SDVOBEs that need assistance in obtaining bonding, insurance, or lines of credit required by the Contractor.

- g. Documentation that qualified M/WBEs or SDVOBEs are not available, or are not interested.
  - h. Attendance at any meeting scheduled by the Department to encourage better Contractor-M/WBE or Contractor- SDVOBE relationships and/or to inform M/WBEs or SDVOBEs of forthcoming M/WBE or SDVOBE utilization opportunities.
  - i. Advertisement, in general circulation media, in trade association publications and in disadvantaged business enterprise-focused media, of interest in utilizing M/WBEs or SDVOBEs and the area of interest.
  - j. Efforts to effectively use the services of available minority community organizations; women organizations, veteran organizations, minority, women disadvantaged and veteran contractor's groups; local, state and federal disadvantaged business assistance offices; and other organizations that provide assistance in recruitment and placement of M/WBEs or SDVOBEs.
9. The demonstration of good faith efforts must establish that the Contractor has actively and aggressively sought out M/WBEs or SDVOBEs to participate in the project and has taken all actions which could be reasonably expected to achieve the goal. Examples of circumstances or actions not acceptable as reasons for failure to meet the M/WBE or SDVOBE goal, include, but are not limited to:
- a. The M/WBE or SDVOBE was unable to provide performance and/or payment bonds.
  - b. The M/WBEs or SDVOBEs commercially reasonable bid was rejected based on price.
  - c. The M/WBE or SDVOBE would not agree to perform items of work at the unit bid price.
  - d. The Contractor does not want to subcontract a percentage of the work sufficient to meet the goal.
  - e. Solicitation by mail or fax only.

### XIII. COMPLIANCE

1. All activity performed by a M/WBE or SDVOBE for credit toward the Contract goal must be performed, managed and supervised by the M/WBE or SDVOBE. Prime Contractor shall not enter into, or condone, any other arrangement.
2. The Prime Contractor shall not perform with its own organization, or assign to any other business, any activity designated for the M/WBEs or SDVOBEs named on the Schedule submitted by the Prime Contractor under Section IX, or under Section XII(6), without the approval of the Department in accordance with the requirements of Sections XIII(6) and XIII(10).
3. The Department may suspend payment for any activity which was not performed by the M/WBE or SDVOBE to whom the activity was committed on the approved Schedule of Participation, or which was not performed in accordance with the requirements of Section XIII(1).
4. The Department retains the right to approve or disapprove all subcontractors. Requests by the Prime Contractor for approval of participation by a M/WBE or SDVOBE subcontractor for credit toward the Contract goal must include, in addition to any other requirements for subcontractor approval, the following:
  - a. A copy of the proposed subcontract. The subcontract must be for at least the dollar amount, and for the work described, in the Prime Contractor's Schedule of Participation.
  - b. A resume stating the qualifications and experience of the M/WBE or SDVOBE superintendent and/or foreperson who will supervise the on-site work. A new resume will be required for any change in supervisory personnel during the progress of the work.
  - c. A Schedule of Operations indicating when the M/WBE or SDVOBE is expected to perform the work.

- d. A list of (1) equipment owned by the M/WBE or SDVOBE to be used on the Project, and (2) equipment to be leased by the M/WBE or SDVOBE for use on the Project.
  - e. A list of: (1) all projects (public and private) which the M/WBE or SDVOBE is currently performing, (2) all projects (public and private) to which the M/WBE or SDVOBE is committed, (3) all projects (public and private) to which the M/WBE or SDVOBE intends to make a commitment. For each contract, list the contracting organization, the name and telephone number of a contact person for the contracting organization, the dollar value of the work, a description of the work, and the M/WBEs or SDVOBEs work schedule for each project.
5. If, pursuant to the subcontractor approval process, the Department finds that a M/WBE or SDVOBE subcontractor does not have sufficient experience or resources to perform, manage and supervise work of the kind proposed in accordance with the requirements of Section XIII(1), approval of the M/WBE or SDVOBE subcontractor may be denied. In the event of such denial, the Prime Contractor shall proceed in accordance with the requirements of Sections XIII(6) and XIII(10).
  6. If, for reasons beyond its control, the Prime Contractor cannot comply with its M/WBE or SDVOBE commitment in accordance with the Schedule of participation submitted under Section IX and the terms of these Special Provisions, the Prime Contractor shall submit to the Department the reasons for its inability to comply with its obligations under Section I and shall submit, and request approval for, a revised Schedule of Participation. If approved by the Department, the revised Schedule shall govern the Prime Contractor's performance in meeting its obligations under these special provisions.
  7. A Prime Contractor's compliance with the participation goal in Section I shall be determined by reference to the required percentage of the total Contract price, including any additions and modifications thereto, provided, however, that no decrease in the dollar amount of a bidder's commitment to any M/WBE or SDVOBE shall be allowed without the approval of the Department.
  8. If the Contract amount is increased, the Prime Contractor shall submit a revised Schedule of Participation in accordance with Sections XIII(6) and XIII(10).
  9. In the event of the decertification of a M/WBE or SDVOBE participating or scheduled to participate on the contract for credit toward the goal, the Contractor shall proceed in accordance with Sections XIII(6) and XIII(10).
  10. The Prime Contractor shall notify the Department immediately of any facts which come to its attention indicating that it may or will be unable to comply with any aspect of its M/WBE or SDVOBE obligation under this Contract.
  11. Any notice required by these Special Provisions shall be given in writing to the Resident Engineer and the district designated Compliance Officer with a copy to the Director of Compliance, Office of Diversity and Civil Rights, 10 Park Plaza, Room 3170, Boston MA 02116.
  12. The Prime Contractor and its subcontractors shall comply with the Department's Electronic Reporting System Requirements (Contract Document 00821) and submit all information required by the Department related to the M/WBE Special Provisions and SDVOBE Special Provisions through the Equitable Business Opportunity Solution (EBO). The Department reserves the right to request reports in the format it deems necessary anytime during the performance of the Contract.
  13. The Contractor shall pay each M/WBE or SDVOBE for satisfactory performance of its Contract no later than 10 days from receipt of payment for the work from the Department. Any delay or postponement of payment to the M/WBEs or SDVOBEs must be for good cause and only with the prior approval of the Department.
  14. The Department may withhold the Contractor's next periodic payment if each M/WBE or SDVOBE is not paid in accordance with Section XIII(13).
  15. The Department may require specific performance of the Prime Contractor's commitment under the Contract by requiring the Prime Contractor to subcontract with a M/WBE or SDVOBE for any contract or specialty item.

#### XIV. SANCTIONS

If the Prime Contractor does not comply with the terms of these Special Provisions and cannot demonstrate to the satisfaction of the Department that good faith efforts were made to achieve such compliance, the Department may, in addition to any other remedy provided for in the Contract, and notwithstanding any other provision in the Contract:

1. Retain, in connection with final acceptance and final payment, an amount determined by multiplying the total contract amount by the percentage in Section I, less the amount paid to approved M/WBEs or SDVOBEs for work performed under the Contract in accordance with the provisions of Section X. The Prime Contractor shall have the right to appeal such retention of funds in accordance with the provisions of M.G.L. c. 30A s.10.
2. Suspend, terminate or cancel this Contract, in whole or in part, and call upon the Prime Contractor's surety to perform all terms and conditions in the Contract.
3. In accordance with 720 CMR 5.05(1)(f), modify or revoke the Prime Contractor's Prequalification status or recommend that the Prime Contractor not receive award of a pending Contract. The Prime Contractor may appeal the determination of the Prequalification Committee in accordance with the provisions of 720 CMR 5.07.
4. Initiate debarment proceedings under M.G.L. c.29 §29F.

#### XV. FURTHER INFORMATION

Any proposed M/WBE, SDVOBE, bidder, Contractor or subcontractor shall provide such information as is necessary in the judgement of the Department to ascertain its compliance with the terms of this Special Provision.

#### XVI. LIST OF ADDITIONAL DOCUMENTS

1. The following documents shall be completed and signed by the bidder and designated M/WBEs or SDVOBEs in accordance with Section XII - Award Documentation and Procedures. These documents must be returned by the bidder to MassDOT's Bid Document Distribution Center:
  - Schedule of M/WBEs (Document B00842) or SDVOBE Participation (Document B00844)
  - Letter of Intent: M/WBEs (Document B00843) or SDVOBE (Document B00845)
  - M/WBEs or SDVOBE Joint Check Arrangement Approval Form (Document B00846), if Contractor and M/WBE or SDVOBE plan, or if M/WBE or SDVOBE is required to use a Joint Check (when applicable)
2. The following document shall be signed and returned by Contractor and Subcontractors/M/WBEs or SDVOBEs to the MassDOT District Office overseeing the Project, as applicable:
  - Contractor/Subcontractor Certification Form (Document No. 00859) (a checklist of other documents to be included with every subcontract (M/WBEs or SDVOBEs and non-M/WBEs or SDVOBEs alike)).
3. The following document shall be provided to MassDOT's Office of Civil Rights and Prequalification Office at least fourteen (14) business days before the bid opening date:
  - Joint Venture Affidavit of M/WBE or SDVOBE/Non-M/WBE or Non-SDVOBE (Document B00847)
4. The following document shall be provided to MassDOT's District Office of Civil Rights within 30 calendar days after the work of the DBE is completed, or no later than 30 calendar days after the work of the DBE is on a completed and processed CQE. This document shall be completed and submitted by the Prime Contractor:
  - Certificate of Completion by a Minority/Women or Disadvantaged Business Enterprise (M/W/DBE) (Form No. CSD-100)

\*\* END OF DOCUMENT \*\*

## DOCUMENT 00761

**SPECIAL PROVISIONS FOR CERTIFICATION REGARDING DEBARMENT,  
SUSPENSION, INELIGIBILITY AND VOLUNTARY EXCLUSION**

Revised: 02/09/16

**I. Instructions for Certification - Primary Covered Transactions:**

By signing and submitting this proposal, the prospective primary participant is providing the certification set out below.

1. The inability of a person to provide the certification set out below will not necessarily result in denial of participation in this covered transaction. The prospective participant shall submit an explanation of why it cannot provide the certification set out below. The certification or explanation will be considered in connection with the MassDOT's determination whether to enter into this transaction. However, failure of the prospective primary participant to furnish a certification or an explanation shall disqualify such a person from participation in this transaction.
2. The certification in this clause is a material representation of fact upon which reliance was placed when the MassDOT determined to enter into this transaction. If it is later determined that the prospective primary participant knowingly rendered an erroneous certification, in addition to other remedies available, the MassDOT may terminate this transaction for cause of default.
3. The prospective primary participant shall provide immediate written notice to the MassDOT if any time the prospective primary participant learns that its certification was erroneous when submitted or has become erroneous by reason of changed circumstances.
4. The terms "covered transaction," "debarred," "suspended," "ineligible," "lower tier covered transaction," "participant," "person," "primary covered transaction," "principal," "proposal," and "voluntarily excluded," as used in this clause, have the meanings set out in the Definitions and Coverage sections of rules implementing Executive Order 12549. You may contact the MassDOT for assistance in obtaining a copy of those regulations.
5. The prospective primary participant agrees by submitting this proposal that, should the proposed covered transaction be entered into, it shall not knowingly enter into any lower tier covered transaction with a person who is debarred, suspended, declared ineligible, or voluntarily excluded from participation in this covered transaction, unless authorized by the MassDOT.
6. The prospective primary participant further agrees by submitting this proposal that it will include the clause titled "Certification Regarding Debarment, Suspension, Ineligibility and Voluntary Exclusion-Lower Tier Covered Transaction," provided by the MassDOT, without modification, in all lower tier covered transactions and in all solicitations for lower tier covered transactions.
7. A participant in a covered transaction may rely upon a certification of a prospective participant in a lower tier covered transaction that is not debarred, suspended, ineligible, or voluntarily excluded from the covered transaction, unless it knows that the certification is erroneous. A participant may decide the method and frequency by which it determines the eligibility of its principals. Each participant may, but is not required to, check the nonprocurement portion of the "Lists of Parties Excluded From Federal Procurement or Nonprocurement Programs" (Nonprocurement List) which is compiled by the General Services Administration and the Debarment Lists compiled by both the Massachusetts Office of the Attorney General and the Department of Capital Asset Management and Maintenance (DCAMM) and published separately in the Central Register.
8. Nothing contained in the foregoing shall be construed to require establishment of a system of records in order to render in good faith the certification required by this clause. The knowledge and information of participant is not required to exceed that which is normally possessed by a prudent person in the ordinary course of business dealings.
9. Except for transactions authorized under paragraph 5 of these instructions, if a participant in a covered transaction knowingly enters into a lower tier covered transaction with a person who is suspended, debarred, ineligible, or voluntarily excluded from participation in this transaction, in addition to other remedies available, the MassDOT may terminate this transaction for cause or default.

\* \* \* \* \*

---

### **Certification Regarding Debarment, Suspension, Ineligibility and Voluntary Exclusion -- Primary Covered Transactions**

The prospective primary participant certifies to the best of its knowledge and belief, that it and its principals:

1. Are not presently debarred, suspended, proposed for debarment, declared ineligible, or voluntarily excluded from covered transactions by any Federal, State or local department or agency;
2. Have not within a 3-year period preceding this proposal been convicted of or had a civil judgement rendered against them for commission of fraud or a criminal offense in connection with obtaining, attempting to obtain, or performing a public (Federal, State or local) transaction or contract under a public transaction; violation of Federal or State antitrust statutes or commission of embezzlement, theft, forgery, bribery, falsification or destruction of records, making false statements, or receiving stolen property;
3. Are not presently indicted for or otherwise criminally or civilly charged by a governmental entity (Federal, State or local) with commission of any of the offenses enumerated in paragraph 2 of this certification; and
4. Have not within a 3-year period preceding this application/proposal had one or more public transactions (Federal, State or local) terminated for cause or default.

Where the prospective primary participant is unable to certify to any of the statements in this certification, such prospective participant shall attach an explanation to this proposal.

\* \* \* \* \*

### **II. Instructions for Certification - Lower Tier Covered Transactions:**

By signing and submitting this proposal, the prospective lower tier participant is providing the certification set out below.

1. The certification in this clause is a material representation of fact upon which reliance was placed when this transaction was entered into. If it is later determined that the prospective lower tier participant knowingly rendered an erroneous certification, in addition to other remedies available the MassDOT may pursue available remedies, including suspension and/or debarment.
2. The prospective lower tier participant shall provide immediate written notice to the person to which this proposal is submitted if at any time the prospective lower tier participant learns that its certification was erroneous by reason of changed circumstances.
3. The terms "covered transaction," "debarred," "suspended," "ineligible," "primary covered transaction," "participant," "person," "principal," "proposal," and "voluntarily excluded," as used in this clause, have the meanings set out in the Definitions and Coverage sections of rules implementing Executive Order 12549. You may contact the MassDOT for assistance in obtaining a copy of those regulations.
4. The prospective lower tier participant agrees by submitting this proposal that, should the proposed covered transaction be entered into, it shall not knowingly enter into any lower tier covered transaction with a person who is debarred, suspended, declared ineligible, or voluntarily excluded from participation in this covered transaction, unless authorized by the MassDOT.
5. The prospective lower tier participant further agrees by submitting this proposal that it will include this clause titled "Certification Regarding Debarment, Suspension, Ineligibility and Voluntary Exclusion-Lower Tier Covered Transaction," without modification, in all lower tier covered transactions and in all solicitations for lower tier covered transactions.
6. A participant in a covered transaction may rely upon a certification of a prospective participant in a lower tier covered transaction that is not debarred, suspended, ineligible, or voluntarily excluded from the covered transaction, unless it knows that the certification is erroneous. A participant may decide the method and frequency by which it determines the eligibility of its principals. Each participant may, but is not required to, check the Nonprocurement List and the Debarment Lists.

7. Nothing contained in the foregoing shall be construed to require establishment of a system of records in order to render in good faith the certification required by this clause. The knowledge and information of participant is not required to exceed that which is normally possessed by a prudent person in the ordinary course of business dealings.
8. Except for transactions authorized under paragraph 4 of these instructions, if a participant in a covered transaction knowingly enters into a lower tier covered transaction with a person who is suspended, debarred, ineligible, or voluntarily excluded from participation in this transaction, the MassDOT may pursue available remedies, including suspension and/or debarment.

\* \* \* \* \*

**Certification Regarding Debarment, Suspension, Ineligibility and Voluntary Exclusion - Lower Tier Covered Transactions**

The prospective lower tier participant certifies, by submission of this proposal, that neither it nor its principals is presently debarred, suspended, proposed for debarment, declared ineligible, or voluntarily excluded from participation in this transaction by any Federal, State or local department or agency.

Where the prospective lower tier participant is unable to certify to any of the statements in this certification, such prospective participant shall attach an explanation to this proposal.

\*\*\* END OF DOCUMENT \*\*\*

THIS PAGE INTENTIONALLY LEFT BLANK



DOCUMENT 00811

SPECIAL PROVISIONS  
MONTHLY PRICE ADJUSTMENT FOR HOT MIX ASPHALT (HMA) MIXTURES  
Revised: 02/03/2023

This provision applies to all projects using greater than 100 tons of hot mix asphalt (HMA) mixtures containing liquid asphalt cement as stipulated in the Notice to Contractors section of the bid documents.

Price Adjustments will be based on the variance in price, for the liquid asphalt component only, between the Base Price and the Period Price. They shall not include transportation or other charges. Price Adjustments will occur on a monthly basis.

**Base Price**

The Base Price of liquid asphalt on a project as listed in the Notice to Contractors section of the bid documents is a fixed price determined by the Department at the time of the bid using the same method as the determination of the Period Price detailed below. The Base Price shall be used in all bids.

**Period Price**

The Period Price is the price of liquid asphalt for each monthly period as determined by the Department using the average selling price per standard ton of PG64-28 paving grade (primary binder classification) asphalt, FOB manufacturer's terminal, as listed under the "East Coast Market - New England, Boston, Massachusetts area" section of the Poten & Partners, Inc. "Asphalt Weekly Monitor". This average selling price is listed in the issue having a publication date of the second Friday of the month and will be posted as the Period Price for that month. The Department will post this Period Price on its website at <https://www.mass.gov/service-details/massdot-current-contract-price-adjustments> following its receipt of the relevant issue of the "Asphalt Weekly Monitor". Poten and Partners has granted the Department the right to publish this specific asphalt price information sourced from the Asphalt Weekly Monitor.

**Price Adjustment Determination, Calculation and Payment**

The Contract Price of the HMA mixture will be paid under the respective item in the Contract. Price Adjustments, as herein provided, either upwards or downwards, will be made after the work has been performed using the monthly period price for the month during which the work was performed.

Price Adjustments will be paid only if the variance from the Base Price is 5% or more for a monthly period. The complete adjustment will be paid in all cases with no deduction of the 5% from either upward or downward adjustments.

The Price Adjustment applies only to the actual virgin liquid asphalt content in the mixture placed on the job in accordance with the approved Job Mix Formula.

Price Adjustments will be separate payment items. The pay item numbers are 999.401 for a positive price adjustment (a payment) and 999.402 for a negative price adjustment (a deduction). Price Adjustments will be calculated using the following equation:

Price Adjustment = Tons of HMA Placed X Liquid Asphalt Content % X RAP Factor X (Period Price - Base Price)

No Price Adjustment will be allowed beyond the Completion Date of this Contract, unless there is a Department-approved extension of time.

\*\*\*\*\* END OF DOCUMENT \*\*\*\*\*

THIS PAGE INTENTIONALLY LEFT BLANK

DOCUMENT 00812

SPECIAL PROVISIONS  
 MONTHLY PRICE ADJUSTMENT FOR DIESEL FUEL AND GASOLINE –  
 ENGLISH UNITS  
 Revised: 02/01/2021

This monthly fuel price adjustment is inserted in this contract because the national and worldwide energy situation has made the future cost of fuel unpredictable. This adjustment will provide for either additional compensation to the Contractor or repayment to the Commonwealth, depending on an increase or decrease in the average price of diesel fuel or gasoline.

This adjustment will be based on fuel usage factors for various items of work developed by the Highway Research Board in Circular 158, dated July 1974. These factors will be multiplied by the quantities of work done in each item during each monthly period and further multiplied by the variance in price from the Base Price to the Period Price.

The Base Price of Diesel Fuel and Gasoline will be the price as indicated in the Department’s web site <https://www.mass.gov/service-details/massdot-current-contract-price-adjustments> for the month in which the contract was bid, which includes State Tax.

The Period Price will be the average of prices charged to the State, including State Tax for the bulk purchases made during each month.

This adjustment will be effected only if the variance from the Base Price is 5% or more for a monthly period. The complete adjustment will be paid in all cases with no deduction of the 5% from either upward or downward adjustments.

No adjustment will be paid for work done beyond the extended completion date of any contract.

Any adjustment (increase or decrease) to estimated quantities made to each item at the time of final payment will have the fuel price adjustment figured at the average period price for the entire term of the project for the difference of quantity.

The fuel price adjustment will apply only to the following items of work at the fuel factors shown:

ITEMS COVERED	FUEL FACTORS	
	Diesel	Gasoline
Excavation: and Borrow Work: Items 120, 120.1, 121, 123, 124, 125, 127, 129.3, 140, 140.1, 141, 142, 143, 144, 150, 150.1, 151 and 151.1 (Both Factors used)	0.29 Gallons / CY.	0.15 Gallons / CY
Surfacing Work: All Items containing Hot Mix Asphalt	2.90 Gallons / Ton	Does Not Apply

\*\*\* END OF DOCUMENT \*\*\*

THIS PAGE INTENTIONALLY LEFT BLANK

## DOCUMENT 00813

## SPECIAL PROVISIONS

## PRICE ADJUSTMENTS FOR STRUCTURAL STEEL AND REINFORCING STEEL

December 12, 2024

This special provision applies to all projects containing the use of structural steel and/or reinforcing steel as specified elsewhere in the Contract work. It applies to all structural steel and all reinforcing steel, as defined below, on the project. Compliance with this provision is mandatory, i.e., there are no “opt-in” or “opt-out” clauses. Price adjustments will be handled as described below and shall only apply to unfabricated reinforcing steel bars and unfabricated structural steel material, consisting of rolled shapes, plate steel, sheet piling, pipe piles, steel castings and steel forgings.

Price adjustments will be variances between Base Prices and Period Prices. Base Prices and Period Prices are defined below.

Price adjustments will only be made if the variances between Base Prices and Period Prices are 5% or more. A variance can result in the Period Price being either higher or lower than the Base Price. Once the 5% threshold has been achieved, the adjustment will apply to the full variance between the Base Price and the Period Price.

Price adjustments will be calculated by multiplying the number of pounds of unfabricated structural steel material or unfabricated reinforcing steel bars on a project by the index factor calculated as shown below under Example of a Period Price Calculation.

Price adjustments will *not* include guardrail panels or the costs of shop drawing preparation, handling, fabrication, coatings, transportation, storage, installation, profit, overhead, fuel costs, fuel surcharges, or other such charges not related to the cost of the unfabricated structural steel and unfabricated reinforcing steel.

The weight of steel subject to a price adjustment shall not exceed the final shipping weight of the fabricated part by more than 10%.

Base Prices and Period Prices are defined as follows:

Base Prices of unfabricated structural steel and unfabricated reinforcing steel on a project are fixed prices determined by the Department and found in the table below. While it is the intention of the Department to make this table comprehensive, some of a project’s unfabricated structural steel and/or unfabricated reinforcing steel may be inadvertently omitted. Should this occur, the Contractor shall bring the omission to the Department’s attention so that a contract alteration may be processed that adds the missing steel to the table and its price adjustments to the Contract.

The Base Price Date is the month and year of the most recent finalized period price index at the time that MassDOT opened bids for the project. The Base Price Index for this contract is the Steel PPI listed in the Notice to Contractors.

Period Prices of unfabricated structural steel and unfabricated reinforcing steel on a project are variable prices that have been calculated using the Period Price Date and an index of steel prices to adjust the Base Price.

The Period Price Date is the date the steel was delivered to the fabricator as evidenced by an official bill of lading submitted to the Department containing a description of the shipped materials, weights of the shipped materials and the date of shipment. This date is used to select the Period Price Index.

The index used for the calculation of Period Prices is the U.S. Department of Labor Bureau of Labor Statistics Producer Price Index (PPI) Series ID WPU101702 (Not Seasonally Adjusted, Group: Metals and Metal Products, Item: Semi-finished Steel Mill Products.) As this index is subject to revision for a period of up to four (4) months after its original publication, no price adjustments will be made until the index for the period is finalized, i.e., the index is no longer suffixed with a “(P)”.

Period Prices are determined as follows:

Period Price = Base Price X Index Factor

Index Factor = Period Price Index / Base Price Index

Example of a Period Price Calculation:

Calculate the Period Price for December 2009 using a Base Price from March 2009 of \$0.82/Pound for 1,000 Pounds of ASTM A709 (AASHTO M270) Grade A36 Structural Steel Plate.

The Period Price Date is December 2009. From the PPI website\*, the Period Price Index = 218.0.

The Base Price Date is March 2009. From the PPI website\*, the Base Price Index = 229.4.

Index Factor = Period Price Index / Base Price Index = 218.0 / 229.4 = 0.950

Period Price = Base Price X Index Factor = \$0.82/Pound X 0.950 = \$0.78/Pound

Since \$0.82 - \$0.78 = \$0.04 is less than 5% of \$0.82, no price adjustment is required.

If the \$0.04 difference shown above was greater than 5% of the Base Price, then the price adjustment would be 1,000 Pounds X \$0.04/Pound = \$40.00. Since the Period Price of \$0.78/Pound is less than the Base Price of \$0.82/Pound, indicating a drop in the price of steel between the bid and the delivery of material, a credit of \$40.00 would be owed to MassDOT. When the Period Price is higher than the Base Price, the price adjustment is owed to the Contractor.

\* To access the PPI website and obtain a Base Price Index or a Period Price Index, go to

<http://data.bls.gov/cgi-bin/srgate>

End of example.

The Contractor will be paid for unfabricated structural steel and unfabricated reinforcing steel under the respective contract pay items for all components constructed of either structural steel or reinforced Portland cement concrete under their respective Contract Pay Items.

Price adjustments, as herein provided for, will be paid separately as follows:

Structural Steel

Pay Item Number 999.449 for positive (+) pay adjustments (payments to the Contractor)

Pay Item Number 999.457 for negative (-) pay adjustments (credits to MassDOT Highway Division)

Reinforcing Steel

Pay Item Number 999.466 for positive (+) pay adjustments (payments to the Contractor)

Pay Item Number 999.467 for negative (-) pay adjustments (credits to MassDOT Highway Division)

No price adjustment will be made for price changes after the Contract Completion Date, unless the MassDOT Highway Division has approved an extension of Contract Time for the Contract.

TABLE

Steel Type	Price per Pound	
1	ASTM A615/A615M Grade 60 (AASHTO M31 Grade 60 or 420) Reinforcing Steel	\$0.58
2	ASTM A27 (AASHTO M103) Steel Castings, H-Pile Points & Pipe Pile Shoes (See Note below.)	\$0.81
3	ASTM A668 / A668M (AASHTO M102) Steel Forgings	\$0.81
4	ASTM A108 (AASHTO M169) Steel Forgings for Shear Studs	\$0.84
5	ASTM A709/A709M Grade 36 / AASHTO M270M/M270 Grade 36 or 250 Structural Steel Plate	\$0.89
6	ASTM A709/A709M Grade 36 / AASHTO M270M/M270 Grade 36 or 250 Structural Steel Shapes	\$0.83
7	ASTM A709/A709M Grade 50 / AASHTO M270M/M270 Grade 50 or 345 Structural Steel Plate	\$0.89
8	ASTM A709/A709M Grade 50 / AASHTO M270M/M270 Grade 50 or 345 Structural Steel Shapes	\$0.83
9	ASTM A709/A709M Grade 50WT / AASHTO M270M/M270 Grade 50WT or 345WT Structural Steel Plate	\$0.92
10	ASTM A709/A709M Grade 50WT / AASHTO M270M/M270 Grade 50WT or 345WT Structural Steel Shapes	\$0.84
11	ASTM A709/A709M Grade 50W / AASHTO M270M/M270 Grade 50W 345W Structural Steel Plate	\$0.92
12	ASTM A709/A709M Grade 50W / AASHTO M270M/M270 Grade 50W or 345W Structural Steel Shapes	\$0.84
13	ASTM A709/A709M Grade HPS 50W / AASHTO M270M/M270 Grade HPS 50W or 345W Structural Steel Plate	\$0.96
14	ASTM A709/A709M Grade HPS 70W / AASHTO M270M/M270 Grade HPS 70W or 485W Structural Steel Plate	\$1.03
15	ASTM A514/A514M-05 Grade HPS 100W / AASHTO M270M/M270 Grade HPS 100W or 690W Structural Steel Plate	\$1.58
16	ASTM A992/A992M Grade 50S / AASHTO M270M/M270 Grade 50S or 345S Structural Steel Plate	\$0.92
17	ASTM A992/A992M Grade 50S / AASHTO M270M/M270 Grade 50S or 345S Structural Steel Shapes	\$0.84
18	ASTM A276 Type 316 Stainless Steel	\$4.71
19	ASTM A240 Type 316 Stainless Steel	\$4.71
20	ASTM A148 Grade 80/50 Steel Castings (See Note below.)	\$1.62
21	ASTM A53 Grade B Structural Steel Pipe	\$1.03
22	ASTM A500 Grades A, B, 36 & 50 Structural Steel Pipe	\$1.03
23	ASTM A252, Grades 240 (36 KSI) & 414 (60 KSI) Pipe Pile	\$0.82
24	ASTM 252, Grade 2 Permanent Steel Casing	\$0.82
25	ASTM A36 (AASHTO M183) for H-piles, steel supports and sign supports	\$0.87
26	ASTM A328 / A328M, Grade 50 (AASHTO M202) Steel Sheetpiling	\$1.55
27	ASTM A572 / A572M, Grade 50 Sheetpiling	\$1.55
28	ASTM A36/36M, Grade 50	\$0.89
29	ASTM A570, Grade 50	\$0.87
30	ASTM A572 (AASHTO M223), Grade 50 H-Piles	\$0.89
31	ASTM A1085 Grade A (50 KSI) Steel Hollow Structural Sections (HSS), heat-treated per ASTM A1085 Supplement S1	\$1.03
32	AREA 140 LB Rail and Track Accessories	\$0.53

**NOTE:** Steel Castings are generally used only on moveable bridges. Cast iron frames, grates and pipe are not "steel" castings and will not be considered for price adjustments.

END OF DOCUMENT

THIS PAGE IS INTENTIONALLY LEFT BLANK



DOCUMENT 00814

SPECIAL PROVISIONS  
PRICE ADJUSTMENT FOR PORTLAND CEMENT CONCRETE MIXES

January 12, 2009

This provision applies to all projects using greater than 100 Cubic Yards (76 Cubic Meters) of Portland cement concrete containing Portland cement as stipulated in the Notice to Contractors section of the Bid Documents. This Price Adjustment will occur on a monthly basis.

The Price Adjustment will be based on the variance in price for the Portland cement component only from the Base Price to the Period Price. It shall not include transportation or other charges.

The Base Price of Portland cement on a project is a fixed price determined at the time of bid by the Department by using the same method as for the determination of the Period Price (see below) and found in the Notice to Contractors.

The Period Price of Portland cement will be determined by using the latest published price, in dollars per ton (U.S.), for Portland cement (Type I) quoted for Boston, U.S.A. in the **Construction Economics** section of *ENR Engineering News-Record* magazine or at the ENR website <http://www.enr.com> under **Construction Economics**. The Period Price will be posted on the MassDOT website the Wednesday immediately following the publishing of the monthly price in ENR, which is normally the first week of the month.

The Contract Price of the Portland cement concrete mix will be paid under the respective item in the Contract. The price adjustment, as herein provided, upwards or downwards, will be made after the work has been performed, using the monthly period price for the month during which the work was performed.

The price adjustment applies only to the actual Portland cement content in the mix placed on the job in accordance with the Standard Specifications for Highways and Bridges, Division III, Section M4.02.01. No adjustments will be made for any cement replacement materials such as fly ash or ground granulated blast furnace slag.

The Price Adjustment will be a separate payment item. It will be determined by multiplying the number of cubic yards of Portland cement concrete placed during each monthly period times the Portland cement content percentage times the variance in price between the Base Price and Period Price of Portland cement.

This Price Adjustment will be paid only if the variance from the Base Price is 5% or more for a monthly period. The complete adjustment will be paid in all cases with no deduction of the 5% from either upward or downward adjustments.

No Price Adjustment will be allowed beyond the Completion Date of this Contract, unless there is a Department-approved extension of time.

\*\*\* END OF DOCUMENT \*\*\*

THIS PAGE INTENTIONALLY LEFT BLANK

DOCUMENT 00820

**THE COMMONWEALTH OF MASSACHUSETTS  
SUPPLEMENTAL EQUAL EMPLOYMENT OPPORTUNITY,  
NON-DISCRIMINATION AND AFFIRMATIVE ACTION PROGRAM**

I. Definitions

For purposes of this contract,

"Minority" means a person who meets one or more of the following definitions:

- (a) American Indian or Native American means: all persons having origins in any of the original peoples of North America and who are recognized as an Indian by a tribe or tribal organization.
- (b) Asian means: All persons having origins in any of the original peoples of the Far East, Southeast Asia, the Indian sub-continent, or the Pacific Islands, including, but Not limited to China, Japan, Korea, Samoa, India, and the Philippine Islands.
- (c) Black means: All persons having origins in any of the Black racial groups of Africa, including, but not limited to, African-Americans, and all persons having origins in any of the original peoples of the Cape Verdean Islands.
- (d) Eskimo or Aleut means: All persons having origins in any of the peoples of Northern Canada, Greenland, Alaska, and Eastern Siberia.
- (e) Hispanic means: All persons having their origins in any of the Spanish-speaking peoples of Mexico, Puerto Rico, Cuba, Central or South America, or the Caribbean Islands.

"State construction contract" means a contract for the construction, reconstruction, installation, demolition, maintenance or repair of a building or capital facility, or a contract for the construction, reconstruction, alteration, remodeling or repair of a public work undertaken by a department, agency, board, or commission of the commonwealth.

"State assisted construction contract" means a contract for the construction, reconstruction, installation, demolition, maintenance or repair of a building or capital facility undertaken by a political subdivision of the commonwealth, or two or more political subdivisions thereof, an authority, or other instrumentality and whose costs of the contract are paid for, reimbursed, grant funded, or otherwise supported, in whole or in part, by the commonwealth.

II. Equal Opportunity, Non-Discrimination and Affirmative Action

During the performance of this Contract, the Contractor and all subcontractors (hereinafter collectively referred to as "the Contractor") for a state construction contract or a state assisted construction contract, for him/herself, his/her assignees and successors in interest, agree to comply with all applicable equal employment opportunity, non-discrimination and affirmative action requirements, including but not limited to the following:

In connection with the performance of work under this contract, the Contractor shall not discriminate against any employee or applicant for employment because of race, color, religious creed, national origin, sex, sexual orientation, genetic information, military service, age, ancestry or disability, shall not discriminate in the selection or retention of subcontractors, and shall not discriminate in the procurement of materials and rentals of equipment.

The aforesaid provision shall include, but not be limited to, the following: employment upgrading, demotion, or transfer; recruitment advertising, layoff or termination; rates of pay or other forms of compensation; conditions or privileges of employment; and selection for apprenticeship or on-the-job training opportunity. The Contractor shall comply with the provisions of chapter 151B of the Massachusetts General Laws, as amended, and all other applicable anti-discrimination and equal opportunity laws, all of which are herein incorporated by reference and made a part of this Contract.

The Contractor shall post hereafter in conspicuous places, available for employees and applicants for employment, notices to be provided by the Massachusetts Commission Against Discrimination setting forth the provisions of the Fair Employment Practices Law of the Commonwealth (Massachusetts General Laws Chapter 151 B).

In connection with the performance of work under this contract, the Contractor shall undertake, in good faith, affirmative action measures to eliminate any discriminatory barriers in the terms and conditions of employment on the grounds of race, color, religious creed, national origin, sex, sexual orientation, genetic information, military service, age, ancestry or disability. Such affirmative action measures shall entail positive and aggressive measures to ensure nondiscrimination and to promote equal opportunity in the areas of hiring, upgrading, demotion or transfer, recruitment, layoff or termination, rate of compensation, apprenticeship and on-the-job training programs. A list of positive and aggressive measures shall include, but not be limited to, advertising employment opportunities in minority and other community news media; notifying minority, women and other community-based organizations of employment opportunities; validating all job specifications, selection requirements, and tests; maintaining a file of names and addresses of each worker referred to the Contractor and what action was taken concerning such worker; and notifying the administering agency in writing when a union with whom the Contractor has a collective bargaining agreement has failed to refer a minority or woman worker. These and other affirmative action measures shall include all actions required to guarantee equal employment opportunity for all persons, regardless of race, color, religious creed, national origin, sex, sexual orientation, genetic information, military service, age, ancestry or disability. One purpose of this provision is to ensure to the fullest extent possible an adequate supply of skilled tradesmen for this and future Commonwealth public construction projects.

### III. Minority and Women Workforce Participation

Pursuant to his/her obligations under the preceding section, the Contractor shall strive to achieve on this project the labor participation goals contained herein. Said participation goals shall apply in each job category on this project including but not limited to bricklayers, carpenters, cement masons, electricians, ironworkers, operating engineers and those classes of work enumerated in Section 44F of Chapter 149 of the Massachusetts General Laws. The participation goals for this project shall be 15.3% for minorities and 6.9% for women. The participation goals, as set forth herein, shall not be construed as quotas or set-asides; rather, such participation goals will be used to measure the progress of the Commonwealth's equal opportunity, non-discrimination and affirmative action program. Additionally, the participation goals contained herein should not be seen or treated as a floor or as a ceiling for the employment of particular individuals or group of individuals.

#### IV. Liaison Committee

At the discretion of the agency that administers the contract for the construction project there may be established for the life of the contract a body to be known as the Liaison Committee. The Liaison Committee shall be composed of one representative each from the agency or agencies administering the contract for the construction project, hereinafter called the administering agency, a representative from the Office of Affirmative action, and such other representatives as may be designated by the administering agency. The Contractor (or his/her agent, if any, designated by him/her as the on-site equal employment opportunity officer) shall recognize the Liaison Committee as an affirmative action body, and shall establish a continuing working relationship with the Liaison Committee, consulting with the Liaison Committee on all matters related to minority recruitment, referral, employment and training.

#### V. Reports and Records

The Contractor shall prepare projected workforce tables on a quarterly basis when required by the administering agency. These shall be broken down into projections, by week, of workers required in each trade. Copies shall be furnished one week in advance of the commencement of the period covered, and also, when updated, to the administering agency and the Liaison Committee when required.

The Contractor shall prepare weekly reports in a form approved by the administering agency, unless information required is required to be reported electronically by the administering agency, the number of hours worked in each trade by each employee, identified as woman, minority, or non-minority. Copies of these shall be provided at the end of each such week to the administering agency and the Liaison Committee.

Records of employment referral orders, prepared by the Contractor, shall be made available to the administering agency on request.

The Contractor will provide all information and reports required by the administering agency on instructions issued by the administering agency and will permit access to its facilities and any books, records, accounts and other sources of information which may be determined by the administering agency to effect the employment of personnel. This provision shall apply only to information pertinent to the Commonwealth's supplementary non-discrimination, equal opportunity and access and opportunity contract requirements. Where information required is in the exclusive possession of another who fails or refuses to furnish this information, the Contractor shall so certify to the administering agency and shall set forth what efforts he has made to obtain the information.

#### VI. Access to Work Site

A designee of the administering agency and a designee of the Liaison Committee shall each have a right to access the work site.

#### VII. Solicitations for Subcontracts, and for the Procurement of Materials and Equipment

In all solicitations either by competitive bidding or negotiation made by the Contractor either for work to be performed under a subcontract or for the procurement of materials or equipment, each potential subcontractor or supplier shall be notified in writing by the Contractor of the Contractor's obligations under this contract relative to non-discrimination and equal opportunity.

## VIII. Sanctions

Whenever the administering agency believes the General or Prime Contractor or any subcontractor may not be operating in compliance with the provisions of the Fair Employment Practices Law of the Commonwealth (Massachusetts General Laws Chapter 151B), the administering agency may refer the matter to the Massachusetts Commission Against Discrimination ("Commission") for investigation.

Following the referral of a matter by the administering agency to the Massachusetts Commission Against Discrimination, and while the matter is pending before the MCAD, the administering agency may withhold payments from contractors and subcontractors when it has documentation that the contractor or subcontractor has violated the Fair Employment Practices Law with respect to its activities on the Project, or if the administering agency determines that the contractor has materially failed to comply with its obligations and the requirements of this Section. The amount withheld shall not exceed a withhold of payment to the General or Prime Contractor of 1/100 or 1% of the contract award price or \$5,000, whichever sum is greater, or, if a subcontractor is in non-compliance, a withhold by the administering agency from the General Contractor, to be assessed by the General Contractor as a charge against the subcontractor, of 1/100 or 1% of the subcontractor price, or \$1,000 whichever sum is greater, for each violation of the applicable law or contract requirements. The total withheld from anyone General or Prime Contractor or subcontractor on a Project shall not exceed \$20,000 overall. No withhold of payments or investigation by the Commission or its agent shall be initiated without the administering agency providing prior notice to the Contractor.

If, after investigation, the Massachusetts Commission Against Discrimination finds that a General or Prime Contractor or subcontractor, in commission of a state construction contract or state-assisted construction contract, violated the provisions of the Fair Employment Practices Law, the administering agency may convert the amount withheld as set forth above into a permanent sanction, as a permanent deduct from payments to the General or Prime Contractor or subcontractor, which sanction will be in addition to any such sanctions, fines or penalties imposed by the Massachusetts Commission Against Discrimination.

No sanction enumerated under this Section shall be imposed by the administering agency except after notice to the General or Prime Contractor or subcontractor and an adjudicatory proceeding, as that term is used, under Massachusetts General Laws Chapter 30A, has been conducted.

## IX. Severability

The provisions of this section are severable, and if any of these provisions shall be held unconstitutional by any court of competent jurisdiction, the decision of such court shall not affect or impair any of the remaining provisions.

X. Contractor's Certification

After award and prior to the execution of any contract for a state construction contract or a state assisted construction contract, the Prime or General Contractor shall certify that it will comply with all provisions of this Document 00820 Supplemental Equal Employment Opportunity, Non-Discrimination and Affirmative Action Program, by executing Document 00859 Contractor/Subcontractor Certification Form.

XI. Subcontractor Requirements

Prior to the award of any subcontract for a state construction contract or a state assisted construction contract, the Prime or General Contractor shall provide all prospective subcontractors with a complete copy of this Document 00820 entitled "Supplemental Equal Employment Opportunity, Non-Discrimination and Affirmative Action Program" and will incorporate the provisions of this Document 00820 into any and all contracts or work orders for all subcontractors providing work on the Project. In order to ensure that the said subcontractor's certification becomes a part of all subcontracts under the prime contract, the Prime or General Contractor shall certify in writing to the administering agency that it has complied with the requirements as set forth in the preceding paragraph by executing Document 00859 Contractor/Subcontractor Certification Form.

*Rev'd 03/07/14*

\*\*\* END OF DOCUMENT \*\*\*

THIS PAGE INTENTIONALLY LEFT BLANK



## DOCUMENT 00821

ELECTRONIC REPORTING REQUIREMENTS  
CIVIL RIGHTS PROGRAMS AND CERTIFIED PAYROLL

Implemented on March 2, 2009

Revised June 04, 2019

The Massachusetts Department Of Transportation (MassDOT) has replaced the CHAMP reporting system with Equitable Business Opportunity Solution (EBO), a new web-based civil rights reporting software system. This system is capable of handling both civil rights reporting requirements and certified payrolls. The program's functions include the administration of Equal Employment Opportunity (EEO) requirements, On-The-Job Training requirements (OJT), Disadvantage Business Enterprise (DBE) and/or Minority / Women's Business Enterprise (M/WBE) subcontracting requirements, and the electronic collection of certified payrolls associated with MassDOT projects. In addition, this system is used to generate various data required as part of the American Recovery and Reinvestment Act (ARRA). Contractors are responsible for all coordination with all sub-contractors to ensure timely and accurate electronic submission of all required data.

## Contractor and Sub-Contractor EBO User Certification

All contractors and sub-contractors must use the EBO software system. The software vendor, Internet Government Solutions (IGS), has developed an online EBO Training Module that is available to contractors and sub-contractors. This module is a self-tutorial which allows all users in the company to access the training, complete the tutorial, and become certified as EBO users for a one time fee of \$75.00. This is the only cost to contractors and sub-contractors associated with the EBO software system. The online EBO Training Module can be accessed at [www.ebotraining.com](http://www.ebotraining.com). Click the "Register My Company" button on the login page to begin your training registration. Questions regarding EBO online training should be directed to Gerry Anguilano, IGS at (440) 238-1684.

MassDOT will track contractors and sub-contractors who have successfully completed the on-line training module. All persons performing civil rights program and/or certified payroll functions should be EBO certified.

## Vetting of Firms and Designated Firm Individuals

Contractors must authorize a Primary Log-In ID Holder who has completed EBO on-line training to have access to the EBO system by completing and submitting the "Request For EBO System Log-In/Password Form" located on the MassDOT website at: <https://www.mass.gov/how-to/how-to-get-an-ebo-login>. Contractors must also agree to comply with the EBO system user agreement located on the MassDOT website.

All subcontracts entered into on a project must include language that identifies the submission and training requirements that the sub-contractor must perform. Sub-contractors will be approved by the respective District Office of MassDOT through the existing approval process. When new sub-contractors, who have not previously worked for MassDOT, are initially selected by a general contractor, the new sub-contractor must be approved by the District before taking the EBO on-line training module.

## Interim Reporting Requirements

Until MassDOT is satisfied that the EBO system is fully operational and functioning as designed, contractors and sub-contractors will be required to submit certified payrolls manually. There will be a transition period where dual reporting, through manual and electronic submission, will be required. MassDOT, however, will notify contractors and sub-contractors when they may cease manual submission of certified payrolls.

\*\*\* END OF DOCUMENT \*\*\*

THIS PAGE INTENTIONALLY LEFT BLANK

DOCUMENT 00859

**CONTRACTOR/SUBCONTRACTOR CERTIFICATION FORM ‡**

*The contractor shall submit this completed document 00859 to MassDOT for each subcontract.*

\_\_\_\_\_ (Contractor) Date: \_\_\_\_\_

\_\_\_\_\_ (Subcontractor)  District Approved Subcontractor

Contract No: 128923 Project No. 613740 Federal Aid No.: NFA

Location: DISTRICT 2

Project Description: Scheduled and Emergency Structural Repairs at Various Locations

**PART 1 CONTRACTOR CERTIFICATION:** I hereby certify, as an authorized official of this company, that to the best of my knowledge, information and belief, the company is in compliance with all applicable federal and state laws, rules, and regulations governing fair labor and employment practices, that the company will not discriminate in their employment practices, that the company will make good faith efforts to comply with the minority employee and women employee workforce participation ratio goals and specific affirmative action steps contained in Contract Document 00820 The Commonwealth of Massachusetts Supplemental Equal Employment Opportunity, Non-Discrimination and Affirmative Action Program, and that the company will comply with the special provisions and documentation indicated below (as checked).

I further hereby certify, as an authorized official of this company, that the special provisions and documentation indicated below (as checked) have been or are included in, and made part of, the Subcontractor Agreement entered into with the firm named above.

**This is not a Federally-aided construction project**

**Document #**

- 00718 –Participation By Minority Or Women's Business Enterprises and SDVOBE†
- 00761 –Certification Regarding Debarment, Suspension, Ineligibility, and Voluntary Exclusion
- 00820 – MA Supplemental Equal Employment Opportunity, Non-Discrimination, and Affirmative Action Program
- 00821 – Electronic Reporting Requirements, Civil Rights Programs, and Certified Payroll
- 00859 – Contractor/Subcontractor Certification Form (this document)
- 00860 – MA Employment Laws
- 00861 – Applicable State Wage Rates in the Contract Proposal\*\*
- B00842 – MA Schedule of Participation By Minority or Women Business Enterprises (M/WBEs)†
- B00843 – MA Letter of Intent – M/WBEs†
  - \*\* Does not apply to Material Suppliers, unless performing work on-site
  - † Applies only if Subcontractor is a M/WBE; only include these forms for the particular M/WBE Entity
- B00844 - Schedule of Participation By SDVOBE
- B00845 - Letter of Intent – SDVOBE
- B00846 – M/WBE or SDVOBE Joint Check Arrangement Approval Form
- B00847 – Joint Venture Affidavit

**This is a Federally-aided construction project (Federal Aid Number is present)**

**Document #**

- 00719 – Special Provisions for Participation by Disadvantaged Business Enterprises†
- 00760 - Form FHWA 1273 - Required Contract Provisions for Federal-Aid Construction Contracts
- 00820 – MA Supplemental Equal Employment Opportunity, Non-Discrimination and Affirmative Action Program
- 00821 – Electronic Reporting Requirements, Civil Rights Programs and Certified Payroll
- 00859 – Contractor/Subcontractor Certification Form (this document)
- 00860 – MA Employment Laws
- 00870 – Standard Federal Equal Employment Opportunity Construction Contract Specifications Executive Order 11246, (41 CFR Parts 60-4.2 and 60-4.3 (Solicitations and Equal Opportunity Clauses)\*
- 00875 – Federal Trainee Special Provisions



- B00853 – Schedule of Participation by Disadvantaged Business Enterprise†
- B00854 – Letter of Intent – DBEs†
- B00855 – DBE Joint Check Arrangement Approval Form
- B00856 – Joint Venture Affidavit
- 00861/00880 - Applicable state and federal wage rates from Contract Proposal\*\*

\*Applicable only to Contracts or Subcontracts in excess of \$10,000

\*\*Does not apply to Material Suppliers, unless performing work on-site

† Applies only if Subcontractor is a DBE; only include these forms for the particular DBE Entity

Signed this \_\_\_\_\_ Day of \_\_\_\_\_, 20\_\_\_\_ Under The Pains And Penalties Of Perjury.

(Print Name and Title)

(Authorized Signature)

**PART 2**

**PART 2. SUBCONTRACTOR CERTIFICATION:** I hereby certify, as an authorized official of this company, that the required documents in Part 1 above were physically incorporated in our Agreement/Subcontract with the Contractor and give assurance that this company will fully comply or make every good faith effort to comply with the same. I further certify that:

1. This company recognizes that if this is a Federal-Aid Project, then this Contract is covered by the equal employment opportunity laws administered and enforced by the United States Department of Labor (“USDOL”), Office of Federal Contract Compliance Programs (“OFCCP”). By signing below, we acknowledge that this company has certain reporting obligations to the OFCCP, as specified by 41 CFR Part 60-4.2.
2. This company further acknowledges that any contractor with fifty (50) or more employees on a Federal-aid Contract with a value of fifty-thousand (\$50,000) dollars or more must annually file an EEO-1 Report (SF 100) to the EEOC, Joint Reporting Committee, on or before September 30th, each year, as specified by 41 CFR Part 60-1.7a.
3. For more information regarding the federal reporting requirements, please contact the USDOL, OFCCP Regional Office, at 1-646-264-3170 or EEO-1, Joint Reporting Committee at 1-866-286-6440. You may also find guidance at: <http://www.dol.gov/ofccp/TAGuides/consttag.pdf> or <http://www.wdol.gov/dba.aspx#0>.
4. This company  has,  has not, participated in a previous contract or subcontract subject to the Equal Opportunity clauses set forth in 41 CFR Part 60-4 and Executive Order 11246, and where required, has filed with the Joint Reporting Committee, the Director of the Office of Federal Contract Compliance Programs or the EEO Commission all reports due under the applicable filing requirements.
5. This company is in full compliance with applicable Federal and Commonwealth of Massachusetts laws, rules, and regulations and is not currently debarred or disqualified from bidding on or participating in construction contracts in any jurisdiction of the United States. See : <https://www.mass.gov/service-details/contractors-and-vendors-suspended-or-debarred-by-massdot>
6. This company is properly registered and in good standing with the Office of the Secretary of the Commonwealth.

Signed this \_\_\_\_\_ Day of \_\_\_\_\_, 20\_\_\_\_, Under The Pains And Penalties Of Perjury.

Firm: \_\_\_\_\_

Address: \_\_\_\_\_

(Print Name and Title)

Telephone Number: \_\_\_\_\_

Federal I.D. Number: \_\_\_\_\_

(Authorized Signature)

Estimated Start Date: \_\_\_\_\_

Estimated Completion Date: \_\_\_\_\_

Estimated Dollar Amount: \_\_\_\_\_

(Date)

DOCUMENT 00860

**COMMONWEALTH OF MASSACHUSETTS PUBLIC EMPLOYMENT LAWS**

Revised February 20, 2019

The Contractor's attention is directed to Massachusetts General Laws, Chapter 149, Sections 26 through 27H, and 150A. This contract is considered to fall within the ambit of that law, which provides that in general, the Prevailing Rate or Total Rate must be paid to employees working on projects funded by the Commonwealth of Massachusetts or any political subdivision including Massachusetts Department of Transportation (MassDOT).

A Federal Aid project is also subject to the Federal Minimum Wage Rate law for construction. When comparing a state minimum wage rate, monitored by the Massachusetts Attorney General, versus federal minimum wage rate, monitored by the U.S. Department of Labor Wage and Hour Division, for a particular job classification the higher wage is at all times to be paid to the affected employee.

Every contractor or subcontractor engaged in this contract to which sections twenty-seven and twenty-seven A apply will keep a true and accurate record of all mechanics and apprentices, teamsters, chauffeurs and laborers employed thereon, showing the name, address and occupational classification of each such employee on this contract, and the hours worked by, and the wages paid to, each such employee, and shall furnish to the MassDOT's Resident Engineer, on a weekly basis, a copy of said record, in a form approved by MassDOT and in accordance with M.G.L. c. 149, § 27B, signed by the employer or his/her authorized agent under the penalties of perjury.

Each such contractor or subcontractor shall preserve its payroll records for a period of three years from the date of completion of the contract.

The Prevailing Wage Rate generally includes the following:

Minimum Hourly Wage + Employer Contributions to Benefit Plans = Prevailing Wage Rate or Total Rate

Any employer who does not make contributions to Benefit Plans must pay the total Prevailing Wage Rate directly to the employee.

Any deduction from the Prevailing Wage Rate or Total Rate for contributions to benefit plans can only be for a Health & Welfare, Pension, or Supplementary Unemployment plan meeting the requirements of the Employee Retirement Income Security Act (ERISA) of 1974. The maximum allowable deduction for these benefits from the prevailing wage rate cannot be greater than the amount allowed by Executive Office of Labor (EOL) for the specified benefits. Any additional expense of providing benefits to the employees is to be borne by the employer and cannot be deducted from the Minimum Hourly Wage. If the employer's benefit expense is less than that so provided by EOL the difference will be paid directly to the employee. The rate established must be paid to all employees who perform work on the project.

When an employer makes deductions from the Minimum Hourly Wage for an employee's contribution to social security, state taxes, federal taxes, and/or other contribution programs, allowed by law, the employer shall furnish each employee a suitable pay slip, check stub or envelope notifying the employee of the amount of the deductions.

No contractor or subcontractor contracting for any part of the contract week shall require or permit any laborer or mechanic to be employed on such work in excess of forty hours in any workweek unless such laborer or mechanic receives compensation at a rate not less than one and one-half times his basic rate of pay for all hours worked in excess of forty hours in such workweek, whichever is the greater number of overtime hours.

Apprentice Rates are permitted only when there is an Apprentice Agreement registered with the Massachusetts Division of Apprentice Training in accordance with M.G.L. c. 23, § 11E-11L.

The Prevailing Wage Rates issued for each project shall be the rates paid for the entire project. The Prevailing Wage Rates must be posted on the job site at all times and be visible from a public way.

In addition, each such contractor and subcontractor shall furnish to the MassDOT's Resident Engineer, within fifteen days after completion of its portion of the work, a statement, executed by the contractor or subcontractor or by any authorized officer or employee of the contractor or subcontractor who supervises the payment of wages, in the following form:

STATEMENT OF COMPLIANCE

Date: \_\_\_\_\_

I, \_\_\_\_\_ do hereby state:  
(Name of signatory party) (Title)

That I pay or supervise the payment of the persons employed by:

\_\_\_\_\_  
(Contractor or Subcontractor)

on the \_\_\_\_\_  
(MassDOT Project Location and Contract Number)

and that all mechanics and apprentices, teamsters, chauffeurs and laborers employed on said project have been paid in accordance with wages determined under the provisions of sections twenty-six and twenty-seven of chapter one hundred and forty-nine of the General Laws.

Signature \_\_\_\_\_

Title \_\_\_\_\_

The above-mentioned copies of payroll records and statements of compliance shall be available for inspection by any interested party filing a written request to the MassDOT's Resident Engineer for such inspection and copying.

Massachusetts General Laws c. 149, §27, requires annual updates to prevailing wage schedules for all public construction contracts lasting longer than one year. MassDOT will request the required updates and furnish them to the Contractor. The Contractor is required to pay no less than the wage rates indicated on the annual updated wage schedules.

MassDOT will request the updates no later than two weeks before the anniversary of the Notice to Proceed date of the contract to allow for adequate processing by the Department of Labor Standards (DLS). The effective date for the new rates will be the anniversary date of the contract (i.e. the notice to proceed date), regardless of the date of issuance on the schedule from DLS.

All bidders are cautioned that the aforementioned laws require that employers pay to covered employees no less than the applicable minimum wages. In addition, the same laws require that the applicable prevailing wages become incorporated as part of this contract. The prevailing minimum wage law establishes serious civil and criminal penalties for violations, including imprisonment and exclusion from future public contracts. Bidders are cautioned to carefully read the relevant sections of the Massachusetts General Laws.

\*\*\* END OF DOCUMENT \*\*\*

DOCUMENT 00861

# **STATE PREVAILING WAGE RATES**

THIS PAGE INTENTIONALLY LEFT BLANK





MAURA HEALEY  
Governor

KIM DRISCOLL  
Lt. Governor

**THE COMMONWEALTH OF MASSACHUSETTS  
EXECUTIVE OFFICE OF LABOR AND WORKFORCE DEVELOPMENT  
DEPARTMENT OF LABOR STANDARDS**

**Prevailing Wage Rates**

**As determined by the Director under the provisions of the  
Massachusetts General Laws, Chapter 149, Sections 26 to 27H**

LAUREN JONES  
Secretary

MICHAEL FLANAGAN  
Director

**Awarding Authority:** MassDOT Highway  
**Contract Number:** 128923 **City/Town:** SPRINGFIELD  
**Description of Work:** DISTRICT 2: Scheduled and Emergency Structural Repairs at Various Locations  
**Job Location:** Distirict-wide

**Information about Prevailing Wage Schedules for Awarding Authorities and Contractors**

- The wage rates will remain in effect for the duration of the project, except in the case of multi-year public construction projects. For construction projects lasting longer than one year, awarding authorities must request an updated wage schedule no later than two weeks before the anniversary of the date the contract was executed by the awarding authority and the general contractor. For multi-year CM AT RISK projects, the awarding authority must request an annual update no later than two weeks before the anniversary date, determined as the earlier of: (a) the execution date of the GMP Amendment, or (b) the execution date of the first amendment to permit procurement of construction services. The updated wage schedule must be provided to all contractors, including general and sub-contractors, working on the construction project.
- This annual update requirement is generally not applicable to 27F "rental of equipment" contracts. For such contracts, the prevailing wage rates issued by DLS shall remain in effect for the duration of the contract term. However, if the prevailing wage rate sheet issued does not contain wage rates for each year covered by the contract term, the Awarding Authority must request updated rate sheets from DLS and provide them to the contractor to ensure the correct rates are being paid throughout the duration of the contract. Additionally, if an Awarding Authority exercises an option to renew or extend the contract term, they must request updated rate sheets form DLS and provide them to the contractor.
- This wage schedule applies only to the specific project referenced at the top of this page and uniquely identified by the "Wage Request Number" on all pages of this schedule.
- An Awarding Authority must request an updated wage schedule if it has not opened bids or selected a contractor within 90 days of the date of issuance of the wage schedule. For CM AT RISK projects (bid pursuant to G.L. c.149A), the earlier of: (a) the execution date of the GMP Amendment, or (b) the bid for the first construction scope of work must be within 90-days of the wage schedule issuance date.
- The wage schedule shall be incorporated in any advertisement or call for bids for the project as required by M.G.L. c. 149, § 27. The wage schedule shall be made a part of the contract awarded for the project. The wage schedule must be posted in a conspicuous place at the work site for the life of the project in accordance with M.G.L. c. 149 § 27. The wages listed on the wage schedule must be paid to employees performing construction work on the project whether they are employed by the prime contractor, a filed sub-bidder, or a sub-contractor.
- Apprentices working on the project are required to be registered with the Massachusetts Division of Apprentice Standards (DAS). Apprentices must keep their apprentice identification card on their persons during all work hours on the project. An apprentice registered with DAS may be paid the lower apprentice wage rate at the applicable step as provided on the prevailing wage schedule. **Any apprentice not registered with DAS regardless of whether they are registered with another federal, state, local, or private agency must be paid the journeyworker's rate.**
- Every contractor or subcontractor working on the construction project must submit weekly payroll reports and a Statement of Compliance directly to the awarding authority by mail or email and keep them on file for three years. Each weekly payroll report must contain: the employee's name, address, occupational classification, hours worked, and wages paid. Do not submit weekly payroll reports to DLS. For a sample payroll reporting form go to <http://www.mass.gov/dols/pw>.
- Contractors with questions about the wage rates or classifications included on the wage schedule have an affirmative obligation to inquire with DLS at (617) 626-6953.
- Contractors must obtain the wage schedules from awarding authorities. Failure of a contractor or subcontractor to pay the prevailing wage rates listed on the wage schedule to all employees who perform construction work on the project is a violation of the law and subjects the contractor or subcontractor to civil and criminal penalties.
- Employees not receiving the prevailing wage rate set forth on the wage schedule may file a complaint with the Fair Labor Division of the office of the Attorney General at (617) 727-3465.

Classification	Effective Date	Base Wage	Health	Pension	Supplemental Unemployment	Total Rate
<b>Construction</b>						
<b>(2 AXLE) DRIVER - EQUIPMENT</b> <i>TEAMSTERS JOINT COUNCIL NO. 10 ZONE B</i>	12/01/2024	\$39.95	\$15.07	\$20.17	\$0.00	\$75.19
	01/01/2025	\$39.95	\$15.57	\$20.17	\$0.00	\$75.69
	06/01/2025	\$40.95	\$15.57	\$20.17	\$0.00	\$76.69
	12/01/2025	\$40.95	\$15.57	\$21.78	\$0.00	\$78.30
	01/01/2026	\$40.95	\$16.17	\$21.78	\$0.00	\$78.90
	06/01/2026	\$41.95	\$16.17	\$21.78	\$0.00	\$79.90
	12/01/2026	\$41.95	\$16.17	\$23.52	\$0.00	\$81.64
	01/01/2027	\$41.95	\$16.77	\$23.52	\$0.00	\$82.24
<b>(3 AXLE) DRIVER - EQUIPMENT</b> <i>TEAMSTERS JOINT COUNCIL NO. 10 ZONE B</i>	12/01/2024	\$40.02	\$15.07	\$20.17	\$0.00	\$75.26
	01/01/2025	\$40.02	\$15.57	\$20.17	\$0.00	\$75.76
	06/01/2025	\$41.02	\$15.57	\$20.17	\$0.00	\$76.76
	12/01/2025	\$41.02	\$15.57	\$21.78	\$0.00	\$78.37
	01/01/2026	\$41.02	\$16.17	\$21.78	\$0.00	\$78.97
	06/01/2026	\$42.02	\$16.17	\$21.78	\$0.00	\$79.97
	12/01/2026	\$42.02	\$16.17	\$23.52	\$0.00	\$81.71
	01/01/2027	\$42.02	\$16.77	\$23.52	\$0.00	\$82.31
<b>(4 &amp; 5 AXLE) DRIVER - EQUIPMENT</b> <i>TEAMSTERS JOINT COUNCIL NO. 10 ZONE B</i>	12/01/2024	\$40.14	\$15.07	\$20.17	\$0.00	\$75.38
	01/01/2025	\$40.14	\$15.57	\$20.17	\$0.00	\$75.88
	06/01/2025	\$41.14	\$15.57	\$20.17	\$0.00	\$76.88
	12/01/2025	\$41.14	\$15.57	\$21.78	\$0.00	\$78.49
	01/01/2026	\$41.14	\$16.17	\$21.78	\$0.00	\$79.09
	06/01/2026	\$42.14	\$16.17	\$21.78	\$0.00	\$80.09
	12/01/2026	\$42.14	\$16.17	\$23.52	\$0.00	\$81.83
	01/01/2027	\$42.14	\$16.77	\$23.52	\$0.00	\$82.43
<b>ADS/SUBMERSIBLE PILOT</b> <i>PILE DRIVER LOCAL 56 (ZONE 3)</i>	08/01/2024	\$117.16	\$10.08	\$24.29	\$0.00	\$151.53
For apprentice rates see "Apprentice- PILE DRIVER"						
<b>AIR TRACK OPERATOR</b> <i>LABORERS - ZONE 3 (BUILDING &amp; SITE)</i>	12/02/2024	\$36.50	\$9.65	\$17.07	\$0.00	\$63.22
	06/02/2025	\$37.75	\$9.65	\$17.07	\$0.00	\$64.47
	12/01/2025	\$39.00	\$9.65	\$17.07	\$0.00	\$65.72
	06/01/2026	\$40.30	\$9.65	\$17.07	\$0.00	\$67.02
	12/07/2026	\$41.60	\$9.65	\$17.07	\$0.00	\$68.32
	06/07/2027	\$43.00	\$9.65	\$17.07	\$0.00	\$69.72
	12/06/2027	\$44.40	\$9.65	\$17.07	\$0.00	\$71.12
	06/05/2028	\$45.90	\$9.65	\$17.07	\$0.00	\$72.62
	12/04/2028	\$47.40	\$9.65	\$17.07	\$0.00	\$74.12
For apprentice rates see "Apprentice- LABORER"						
<b>AIR TRACK OPERATOR (HEAVY &amp; HIGHWAY)</b> <i>LABORERS - ZONE 3 (HEAVY &amp; HIGHWAY)</i>	12/01/2024	\$36.50	\$9.65	\$15.06	\$0.00	\$61.21
	06/01/2025	\$37.75	\$9.65	\$15.06	\$0.00	\$62.46
	12/01/2025	\$38.99	\$9.65	\$15.06	\$0.00	\$63.70
	06/01/2026	\$40.29	\$9.65	\$15.06	\$0.00	\$65.00
	12/01/2026	\$41.58	\$9.65	\$15.06	\$0.00	\$66.29
For apprentice rates see "Apprentice- LABORER (Heavy and Highway)"						

Classification	Effective Date	Base Wage	Health	Pension	Supplemental Unemployment	Total Rate
ASBESTOS WORKER (PIPES & TANKS) <i>HEAT &amp; FROST INSULATORS LOCAL 6 (SPRINGFIELD)</i>	12/01/2024	\$38.52	\$14.50	\$10.55	\$0.00	\$63.57
	06/01/2025	\$39.42	\$14.50	\$10.55	\$0.00	\$64.47
	12/01/2025	\$40.32	\$14.50	\$10.55	\$0.00	\$65.37
ASPHALT RAKER <i>LABORERS - ZONE 3 (BUILDING &amp; SITE)</i>	12/02/2024	\$36.00	\$9.65	\$17.07	\$0.00	\$62.72
	06/02/2025	\$37.25	\$9.65	\$17.07	\$0.00	\$63.97
	12/01/2025	\$38.50	\$9.65	\$17.07	\$0.00	\$65.22
	06/01/2026	\$39.80	\$9.65	\$17.07	\$0.00	\$66.52
	12/07/2026	\$41.10	\$9.65	\$17.07	\$0.00	\$67.82
	06/07/2027	\$42.50	\$9.65	\$17.07	\$0.00	\$69.22
	12/06/2027	\$43.90	\$9.65	\$17.07	\$0.00	\$70.62
	06/05/2028	\$45.40	\$9.65	\$17.07	\$0.00	\$72.12
12/04/2028	\$46.90	\$9.65	\$17.07	\$0.00	\$73.62	
For apprentice rates see "Apprentice- LABORER"						
ASPHALT RAKER (HEAVY & HIGHWAY) <i>LABORERS - ZONE 3 (HEAVY &amp; HIGHWAY)</i>	12/01/2024	\$36.00	\$9.65	\$15.06	\$0.00	\$60.71
	06/01/2025	\$37.25	\$9.65	\$15.06	\$0.00	\$61.96
	12/01/2025	\$38.49	\$9.65	\$15.06	\$0.00	\$63.20
	06/01/2026	\$39.79	\$9.65	\$15.06	\$0.00	\$64.50
	12/01/2026	\$41.08	\$9.65	\$15.06	\$0.00	\$65.79
For apprentice rates see "Apprentice- LABORER (Heavy and Highway)"						
AUTOMATIC GRADER-EXCAVATOR (RECLAIMER) <i>OPERATING ENGINEERS LOCAL 98</i>	12/01/2023	\$39.56	\$13.78	\$15.15	\$0.00	\$68.49
For apprentice rates see "Apprentice- OPERATING ENGINEERS"						
BACKHOE/FRONT-END LOADER OPERATOR <i>OPERATING ENGINEERS LOCAL 98</i>	12/01/2023	\$39.56	\$13.78	\$15.15	\$0.00	\$68.49
For apprentice rates see "Apprentice- OPERATING ENGINEERS"						
BARCO-TYPE JUMPING TAMPER <i>LABORERS - ZONE 3 (BUILDING &amp; SITE)</i>	12/02/2024	\$36.00	\$9.65	\$17.07	\$0.00	\$62.72
	06/02/2025	\$37.25	\$9.65	\$17.07	\$0.00	\$63.97
	12/01/2025	\$38.50	\$9.65	\$17.07	\$0.00	\$65.22
	06/01/2026	\$39.80	\$9.65	\$17.07	\$0.00	\$66.52
	12/07/2026	\$41.10	\$9.65	\$17.07	\$0.00	\$67.82
	06/07/2027	\$42.50	\$9.65	\$17.07	\$0.00	\$69.22
	12/06/2027	\$43.90	\$9.65	\$17.07	\$0.00	\$70.62
	06/05/2028	\$45.40	\$9.65	\$17.07	\$0.00	\$72.12
12/04/2028	\$46.90	\$9.65	\$17.07	\$0.00	\$73.62	
For apprentice rates see "Apprentice- LABORER"						
BATCH/CEMENT PLANT - ON SITE <i>OPERATING ENGINEERS LOCAL 98</i>	12/01/2023	\$39.03	\$13.78	\$15.15	\$0.00	\$67.96
For apprentice rates see "Apprentice- OPERATING ENGINEERS"						
BLOCK PAVER, RAMMER / CURB SETTER <i>LABORERS - ZONE 3 (BUILDING &amp; SITE)</i>	12/02/2024	\$36.50	\$9.65	\$17.07	\$0.00	\$63.22
	06/02/2025	\$37.75	\$9.65	\$17.07	\$0.00	\$64.47
	12/01/2025	\$39.00	\$9.65	\$17.07	\$0.00	\$65.72
	06/01/2026	\$40.30	\$9.65	\$17.07	\$0.00	\$67.02
	12/07/2026	\$41.60	\$9.65	\$17.07	\$0.00	\$68.32
	06/07/2027	\$43.00	\$9.65	\$17.07	\$0.00	\$69.72
	12/06/2027	\$44.40	\$9.65	\$17.07	\$0.00	\$71.12
	06/05/2028	\$45.90	\$9.65	\$17.07	\$0.00	\$72.62
12/04/2028	\$47.40	\$9.65	\$17.07	\$0.00	\$74.12	
For apprentice rates see "Apprentice- LABORER"						

Classification	Effective Date	Base Wage	Health	Pension	Supplemental Unemployment	Total Rate
BLOCK PAVER, RAMMER / CURB SETTER (HEAVY & HIGHWAY) <i>LABORERS - ZONE 3 (HEAVY &amp; HIGHWAY)</i>	12/01/2024	\$36.50	\$9.65	\$15.06	\$0.00	\$61.21
	06/01/2025	\$37.75	\$9.65	\$15.06	\$0.00	\$62.46
	12/01/2025	\$38.99	\$9.65	\$15.06	\$0.00	\$63.70
	06/01/2026	\$40.29	\$9.65	\$15.06	\$0.00	\$65.00
	12/01/2026	\$41.58	\$9.65	\$15.06	\$0.00	\$66.29
For apprentice rates see "Apprentice- LABORER (Heavy and Highway)						
BOILER MAKER <i>BOILERMAKERS LOCAL 29</i>	01/01/2024	\$48.12	\$7.07	\$20.60	\$0.00	\$75.79

**Apprentice - BOILERMAKER - Local 29**

**Effective Date - 01/01/2024**

Step	percent	Apprentice Base Wage	Health	Pension	Supplemental Unemployment	Total Rate
1	65	\$31.28	\$7.07	\$13.22	\$0.00	\$51.57
2	65	\$31.28	\$7.07	\$13.22	\$0.00	\$51.57
3	70	\$33.68	\$7.07	\$14.23	\$0.00	\$54.98
4	75	\$36.09	\$7.07	\$15.24	\$0.00	\$58.40
5	80	\$38.50	\$7.07	\$16.25	\$0.00	\$61.82
6	85	\$40.90	\$7.07	\$17.28	\$0.00	\$65.25
7	90	\$43.31	\$7.07	\$18.28	\$0.00	\$68.66
8	95	\$45.71	\$7.07	\$19.32	\$0.00	\$72.10

**Notes:**

**Apprentice to Journeyworker Ratio:1:4**

BRICK/STONE/ARTIFICIAL MASONRY (INCL. MASONRY WATERPROOFING) <i>BRICKLAYERS LOCAL 3 (SPRINGFIELD/PITTSFIELD)</i>	08/01/2024	\$52.06	\$11.49	\$21.46	\$0.00	\$85.01
	02/01/2025	\$53.36	\$11.49	\$21.46	\$0.00	\$86.31
	08/01/2025	\$55.51	\$11.49	\$21.46	\$0.00	\$88.46
	02/01/2026	\$56.86	\$11.49	\$21.46	\$0.00	\$89.81
	08/01/2026	\$59.06	\$11.49	\$21.46	\$0.00	\$92.01
	02/01/2027	\$60.46	\$11.49	\$21.46	\$0.00	\$93.41

<b>Classification</b>	<b>Effective Date</b>	<b>Base Wage</b>	<b>Health</b>	<b>Pension</b>	<b>Supplemental Unemployment</b>	<b>Total Rate</b>
-----------------------	-----------------------	------------------	---------------	----------------	----------------------------------	-------------------

**Apprentice - BRICK/PLASTER/CEMENT MASON - Local 3 Springfield/Pittsfield**

**Effective Date - 08/01/2024**

Step	percent	Apprentice Base Wage	Health	Pension	Supplemental Unemployment	Total Rate
1	50	\$26.03	\$11.49	\$21.46	\$0.00	\$58.98
2	60	\$31.24	\$11.49	\$21.46	\$0.00	\$64.19
3	70	\$36.44	\$11.49	\$21.46	\$0.00	\$69.39
4	80	\$41.65	\$11.49	\$21.46	\$0.00	\$74.60
5	90	\$46.85	\$11.49	\$21.46	\$0.00	\$79.80

**Effective Date - 02/01/2025**

Step	percent	Apprentice Base Wage	Health	Pension	Supplemental Unemployment	Total Rate
1	50	\$26.68	\$11.49	\$21.46	\$0.00	\$59.63
2	60	\$32.02	\$11.49	\$21.46	\$0.00	\$64.97
3	70	\$37.35	\$11.49	\$21.46	\$0.00	\$70.30
4	80	\$42.69	\$11.49	\$21.46	\$0.00	\$75.64
5	90	\$48.02	\$11.49	\$21.46	\$0.00	\$80.97

**Notes:**

**Apprentice to Journeyworker Ratio:1:5**

BULLDOZER/POWER SHOVEL/TREE SHREDDER /CLAM SHELL OPERATING	12/01/2023	\$39.56	\$13.78	\$15.15	\$0.00	\$68.49
---	------------	---------	---------	---------	--------	---------

*ENGINEERS LOCAL 98*

For apprentice rates see "Apprentice- OPERATING ENGINEERS"

CAISSON & UNDERPINNING BOTTOM MAN LABORERS - FOUNDATION AND MARINE	12/01/2024	\$48.10	\$9.65	\$18.22	\$0.00	\$75.97
	06/01/2025	\$49.60	\$9.65	\$18.22	\$0.00	\$77.47
	12/01/2025	\$51.10	\$9.65	\$18.22	\$0.00	\$78.97
	06/01/2026	\$52.65	\$9.65	\$18.22	\$0.00	\$80.52
	12/01/2026	\$54.15	\$9.65	\$18.22	\$0.00	\$82.02

For apprentice rates see "Apprentice- LABORER"

CAISSON & UNDERPINNING LABORER LABORERS - FOUNDATION AND MARINE	12/01/2024	\$46.95	\$9.65	\$18.22	\$0.00	\$74.82
	06/01/2025	\$48.45	\$9.65	\$18.22	\$0.00	\$76.32
	12/01/2025	\$49.95	\$9.65	\$18.22	\$0.00	\$77.82
	06/01/2026	\$51.50	\$9.65	\$18.22	\$0.00	\$79.37
	12/01/2026	\$53.00	\$9.65	\$18.22	\$0.00	\$80.87

For apprentice rates see "Apprentice- LABORER"

CAISSON & UNDERPINNING TOP MAN LABORERS - FOUNDATION AND MARINE	12/01/2024	\$47.28	\$9.65	\$18.22	\$0.00	\$75.15
	06/01/2025	\$48.78	\$9.65	\$18.22	\$0.00	\$76.65
	12/01/2025	\$50.28	\$9.65	\$18.22	\$0.00	\$78.15
	06/01/2026	\$51.83	\$9.65	\$18.22	\$0.00	\$79.70
	12/01/2026	\$53.33	\$9.65	\$18.22	\$0.00	\$81.20

For apprentice rates see "Apprentice- LABORER"

Classification	Effective Date	Base Wage	Health	Pension	Supplemental Unemployment	Total Rate
CARBIDE CORE DRILL OPERATOR <i>LABORERS - ZONE 3 (BUILDING &amp; SITE)</i>	12/02/2024	\$36.00	\$9.65	\$17.07	\$0.00	\$62.72
	06/02/2025	\$37.25	\$9.65	\$17.07	\$0.00	\$63.97
	12/01/2025	\$38.50	\$9.65	\$17.07	\$0.00	\$65.22
	06/01/2026	\$39.80	\$9.65	\$17.07	\$0.00	\$66.52
	12/07/2026	\$41.10	\$9.65	\$17.07	\$0.00	\$67.82
	06/07/2027	\$42.50	\$9.65	\$17.07	\$0.00	\$69.22
	12/06/2027	\$43.90	\$9.65	\$17.07	\$0.00	\$70.62
	06/05/2028	\$45.40	\$9.65	\$17.07	\$0.00	\$72.12
	12/04/2028	\$46.90	\$9.65	\$17.07	\$0.00	\$73.62

For apprentice rates see "Apprentice- LABORER"

CARPENTER <i>CARPENTERS LOCAL 336 - HAMPDEN HAMPSHIRE FRANKLIN</i>	09/01/2024	\$42.36	\$7.91	\$18.15	\$0.00	\$68.42
	03/01/2025	\$43.26	\$7.91	\$18.15	\$0.00	\$69.32
	09/01/2025	\$44.21	\$7.91	\$18.15	\$0.00	\$70.27
	03/01/2026	\$45.11	\$7.91	\$18.15	\$0.00	\$71.17
	09/01/2026	\$46.06	\$7.91	\$18.15	\$0.00	\$72.12
	03/01/2027	\$46.96	\$7.91	\$18.15	\$0.00	\$73.02

**Apprentice - CARPENTER - Local 336 Hampden Hampshire Franklin**

**Effective Date - 09/01/2024**

Step	percent	Apprentice Base Wage	Health	Pension	Supplemental Unemployment	Total Rate
1	45	\$19.06	\$7.91	\$1.40	\$0.00	\$28.37
2	45	\$19.06	\$7.91	\$1.40	\$0.00	\$28.37
3	55	\$23.30	\$7.91	\$2.76	\$0.00	\$33.97
4	55	\$23.30	\$7.91	\$2.76	\$0.00	\$33.97
5	70	\$29.65	\$7.91	\$15.39	\$0.00	\$52.95
6	70	\$29.65	\$7.91	\$15.39	\$0.00	\$52.95
7	80	\$33.89	\$7.91	\$16.77	\$0.00	\$58.57
8	80	\$33.89	\$7.91	\$16.77	\$0.00	\$58.57

**Effective Date - 03/01/2025**

Step	percent	Apprentice Base Wage	Health	Pension	Supplemental Unemployment	Total Rate
1	45	\$19.47	\$7.91	\$1.40	\$0.00	\$28.78
2	45	\$19.47	\$7.91	\$1.40	\$0.00	\$28.78
3	55	\$23.79	\$7.91	\$2.76	\$0.00	\$34.46
4	55	\$23.79	\$7.91	\$2.76	\$0.00	\$34.46
5	70	\$30.28	\$7.91	\$15.39	\$0.00	\$53.58
6	70	\$30.28	\$7.91	\$15.39	\$0.00	\$53.58
7	80	\$34.61	\$7.91	\$16.77	\$0.00	\$59.29
8	80	\$34.61	\$7.91	\$16.77	\$0.00	\$59.29

**Notes:**

**Apprentice to Journeyworker Ratio:1:5**

Classification	Effective Date	Base Wage	Health	Pension	Supplemental Unemployment	Total Rate
CARPENTER WOOD FRAME	10/01/2024	\$26.65	\$7.02	\$4.80	\$0.00	\$38.47
<i>CARPENTERS-ZONE 3 (Wood Frame)</i>	10/01/2025	\$27.75	\$7.02	\$4.80	\$0.00	\$39.57
	10/01/2026	\$28.85	\$7.02	\$4.80	\$0.00	\$40.67

All Aspects of New Wood Frame Work

**Apprentice - CARPENTER (Wood Frame) - Zone 3**

**Effective Date - 10/01/2024**

Step	percent	Apprentice Base Wage	Health	Pension	Supplemental Unemployment	Total Rate
1	60	\$15.99	\$7.02	\$0.00	\$0.00	\$23.01
2	60	\$15.99	\$7.02	\$0.00	\$0.00	\$23.01
3	65	\$17.32	\$7.02	\$1.00	\$0.00	\$25.34
4	70	\$18.66	\$7.02	\$1.00	\$0.00	\$26.68
5	75	\$19.99	\$7.02	\$4.80	\$0.00	\$31.81
6	80	\$21.32	\$7.02	\$4.80	\$0.00	\$33.14
7	85	\$22.65	\$7.02	\$4.80	\$0.00	\$34.47
8	90	\$23.99	\$7.02	\$4.80	\$0.00	\$35.81

**Effective Date - 10/01/2025**

Step	percent	Apprentice Base Wage	Health	Pension	Supplemental Unemployment	Total Rate
1	60	\$16.65	\$7.02	\$0.00	\$0.00	\$23.67
2	60	\$16.65	\$7.02	\$0.00	\$0.00	\$23.67
3	65	\$18.04	\$7.02	\$1.00	\$0.00	\$26.06
4	70	\$19.43	\$7.02	\$1.00	\$0.00	\$27.45
5	75	\$20.81	\$7.02	\$4.80	\$0.00	\$32.63
6	80	\$22.20	\$7.02	\$4.80	\$0.00	\$34.02
7	85	\$23.59	\$7.02	\$4.80	\$0.00	\$35.41
8	90	\$24.98	\$7.02	\$4.80	\$0.00	\$36.80

**Notes:**

---

**Apprentice to Journeyworker Ratio:1:5**

CEMENT MASONRY/PLASTERING	01/01/2024	\$44.68	\$12.90	\$18.66	\$1.25	\$77.49
<i>BRICKLAYERS LOCAL 3 (SPRINGFIELD/PITTSFIELD)</i>						

<b>Classification</b>	<b>Effective Date</b>	<b>Base Wage</b>	<b>Health</b>	<b>Pension</b>	<b>Supplemental Unemployment</b>	<b>Total Rate</b>
-----------------------	-----------------------	------------------	---------------	----------------	----------------------------------	-------------------

**Apprentice - CEMENT MASONRY/PLASTERING - Springfield/Pittsfield**

**Effective Date - 01/01/2024**

Step	percent	Apprentice Base Wage	Health	Pension	Supplemental Unemployment	Total Rate
1	50	\$22.34	\$12.90	\$15.86	\$0.00	\$51.10
2	60	\$26.81	\$12.90	\$18.66	\$1.25	\$59.62
3	65	\$29.04	\$12.90	\$18.66	\$1.25	\$61.85
4	70	\$31.28	\$12.90	\$18.66	\$1.25	\$64.09
5	75	\$33.51	\$12.90	\$18.66	\$1.25	\$66.32
6	80	\$35.74	\$12.90	\$18.66	\$1.25	\$68.55
7	90	\$40.21	\$12.90	\$18.66	\$1.25	\$73.02

**Notes:**  
Steps 3,4 are 500 hrs. All other steps are 1,000 hrs.

**Apprentice to Journeyworker Ratio:1:3**

<b>CHAIN SAW OPERATOR</b> <i>LABORERS - ZONE 3 (BUILDING &amp; SITE)</i>	12/02/2024	\$36.00	\$9.65	\$17.07	\$0.00	\$62.72
	06/02/2025	\$37.25	\$9.65	\$17.07	\$0.00	\$63.97
	12/01/2025	\$38.50	\$9.65	\$17.07	\$0.00	\$65.22
	06/01/2026	\$39.80	\$9.65	\$17.07	\$0.00	\$66.52
	12/07/2026	\$41.10	\$9.65	\$17.07	\$0.00	\$67.82
	06/07/2027	\$42.50	\$9.65	\$17.07	\$0.00	\$69.22
	12/06/2027	\$43.90	\$9.65	\$17.07	\$0.00	\$70.62
	06/05/2028	\$45.40	\$9.65	\$17.07	\$0.00	\$72.12
	12/04/2028	\$46.90	\$9.65	\$17.07	\$0.00	\$73.62

For apprentice rates see "Apprentice- LABORER"

<b>COMPRESSOR OPERATOR</b> <i>OPERATING ENGINEERS LOCAL 98</i>	12/01/2023	\$39.03	\$13.78	\$15.15	\$0.00	\$67.96
---	------------	---------	---------	---------	--------	---------

For apprentice rates see "Apprentice- OPERATING ENGINEERS"

<b>CRANE OPERATOR</b> <i>OPERATING ENGINEERS LOCAL 98</i>	12/01/2023	\$43.06	\$13.78	\$15.15	\$0.00	\$71.99
--	------------	---------	---------	---------	--------	---------

For apprentice rates see "Apprentice- OPERATING ENGINEERS"

<b>DELEADER (BRIDGE)</b> <i>PAINTERS LOCAL 35 - ZONE 3</i>	07/01/2024	\$57.26	\$9.95	\$23.95	\$0.00	\$91.16
	01/01/2025	\$58.46	\$9.95	\$23.95	\$0.00	\$92.36



**Classification**

**Effective Date    Base Wage    Health    Pension    Supplemental Unemployment    Total Rate**

**Apprentice - PAINTER Local 35 - BRIDGES/TANKS**

**Effective Date - 07/01/2024**

Step	percent	Apprentice Base Wage	Health	Pension	Supplemental Unemployment	Total Rate
1	50	\$28.63	\$9.95	\$0.00	\$0.00	\$38.58
2	55	\$31.49	\$9.95	\$6.66	\$0.00	\$48.10
3	60	\$34.36	\$9.95	\$7.26	\$0.00	\$51.57
4	65	\$37.22	\$9.95	\$7.87	\$0.00	\$55.04
5	70	\$40.08	\$9.95	\$20.32	\$0.00	\$70.35
6	75	\$42.95	\$9.95	\$20.93	\$0.00	\$73.83
7	80	\$45.81	\$9.95	\$21.53	\$0.00	\$77.29
8	90	\$51.53	\$9.95	\$22.74	\$0.00	\$84.22

**Effective Date - 01/01/2025**

Step	percent	Apprentice Base Wage	Health	Pension	Supplemental Unemployment	Total Rate
1	50	\$29.23	\$9.95	\$0.00	\$0.00	\$39.18
2	55	\$32.15	\$9.95	\$6.66	\$0.00	\$48.76
3	60	\$35.08	\$9.95	\$7.26	\$0.00	\$52.29
4	65	\$38.00	\$9.95	\$7.87	\$0.00	\$55.82
5	70	\$40.92	\$9.95	\$20.32	\$0.00	\$71.19
6	75	\$43.85	\$9.95	\$20.93	\$0.00	\$74.73
7	80	\$46.77	\$9.95	\$21.53	\$0.00	\$78.25
8	90	\$52.61	\$9.95	\$22.74	\$0.00	\$85.30

**Notes:**  
Steps are 750 hrs.

**Apprentice to Journeyworker Ratio:1:1**

DEMO: ADZEMAN	12/02/2024	\$47.00	\$9.65	\$18.40	\$0.00	\$75.05
LABORERS - ZONE 3 (BUILDING & SITE)	06/02/2025	\$48.50	\$9.65	\$18.40	\$0.00	\$76.55
	12/01/2025	\$50.00	\$9.65	\$18.40	\$0.00	\$78.05
	06/01/2026	\$51.55	\$9.65	\$18.40	\$0.00	\$79.60
	12/07/2026	\$53.05	\$9.65	\$18.40	\$0.00	\$81.10
	06/07/2027	\$54.65	\$9.65	\$18.40	\$0.00	\$82.70
	12/06/2027	\$56.25	\$9.65	\$18.40	\$0.00	\$84.30
	06/05/2028	\$57.93	\$9.65	\$18.40	\$0.00	\$85.98
	12/04/2028	\$59.60	\$9.65	\$18.40	\$0.00	\$87.65

For apprentice rates see "Apprentice- LABORER"

Classification	Effective Date	Base Wage	Health	Pension	Supplemental Unemployment	Total Rate
<b>DEMO: BACKHOE/LOADER/HAMMER OPERATOR</b> <i>LABORERS - ZONE 3 (BUILDING &amp; SITE)</i>	12/02/2024	\$48.00	\$9.65	\$18.40	\$0.00	\$76.05
	06/02/2025	\$49.50	\$9.65	\$18.40	\$0.00	\$77.55
	12/01/2025	\$51.00	\$9.65	\$18.40	\$0.00	\$79.05
	06/01/2026	\$52.55	\$9.65	\$18.40	\$0.00	\$80.60
	12/07/2026	\$54.05	\$9.65	\$18.40	\$0.00	\$82.10
	06/07/2027	\$55.65	\$9.65	\$18.40	\$0.00	\$83.70
	12/06/2027	\$57.25	\$9.65	\$18.40	\$0.00	\$85.30
	06/05/2028	\$58.93	\$9.65	\$18.40	\$0.00	\$86.98
	12/04/2028	\$60.60	\$9.65	\$18.40	\$0.00	\$88.65
For apprentice rates see "Apprentice- LABORER"						
<b>DEMO: BURNERS</b> <i>LABORERS - ZONE 3 (BUILDING &amp; SITE)</i>	12/02/2024	\$47.75	\$9.65	\$18.40	\$0.00	\$75.80
	06/02/2025	\$49.25	\$9.65	\$18.40	\$0.00	\$77.30
	12/01/2025	\$50.75	\$9.65	\$18.40	\$0.00	\$78.80
	06/01/2026	\$52.30	\$9.65	\$18.40	\$0.00	\$80.35
	12/07/2026	\$53.80	\$9.65	\$18.40	\$0.00	\$81.85
	06/07/2027	\$55.40	\$9.65	\$18.40	\$0.00	\$83.45
	12/06/2027	\$57.00	\$9.65	\$18.40	\$0.00	\$85.05
	06/05/2028	\$58.68	\$9.65	\$18.40	\$0.00	\$86.73
	12/04/2028	\$60.35	\$9.65	\$18.40	\$0.00	\$88.40
For apprentice rates see "Apprentice- LABORER"						
<b>DEMO: CONCRETE CUTTER/SAWYER</b> <i>LABORERS - ZONE 3 (BUILDING &amp; SITE)</i>	12/02/2024	\$48.00	\$9.65	\$18.40	\$0.00	\$76.05
	06/02/2025	\$49.50	\$9.65	\$18.40	\$0.00	\$77.55
	12/01/2025	\$51.00	\$9.65	\$18.40	\$0.00	\$79.05
	06/01/2026	\$52.55	\$9.65	\$18.40	\$0.00	\$80.60
	12/07/2026	\$54.05	\$9.65	\$18.40	\$0.00	\$82.10
	06/07/2027	\$55.65	\$9.65	\$18.40	\$0.00	\$83.70
	12/06/2027	\$57.25	\$9.65	\$18.40	\$0.00	\$85.30
	06/05/2028	\$58.93	\$9.65	\$18.40	\$0.00	\$86.98
	12/04/2028	\$60.60	\$9.65	\$18.40	\$0.00	\$88.65
For apprentice rates see "Apprentice- LABORER"						
<b>DEMO: JACKHAMMER OPERATOR</b> <i>LABORERS - ZONE 3 (BUILDING &amp; SITE)</i>	12/02/2024	\$47.75	\$9.65	\$18.40	\$0.00	\$75.80
	06/02/2025	\$49.25	\$9.65	\$18.40	\$0.00	\$77.30
	12/01/2025	\$50.75	\$9.65	\$18.40	\$0.00	\$78.80
	06/01/2026	\$52.30	\$9.65	\$18.40	\$0.00	\$80.35
	12/07/2026	\$53.80	\$9.65	\$18.40	\$0.00	\$81.85
	06/07/2027	\$55.40	\$9.65	\$18.40	\$0.00	\$83.45
	12/06/2027	\$57.00	\$9.65	\$18.40	\$0.00	\$85.05
	06/05/2028	\$58.68	\$9.65	\$18.40	\$0.00	\$86.73
	12/04/2028	\$60.35	\$9.65	\$18.40	\$0.00	\$88.40
For apprentice rates see "Apprentice- LABORER"						

Classification	Effective Date	Base Wage	Health	Pension	Supplemental Unemployment	Total Rate
<b>DEMO: WRECKING LABORER</b> <i>LABORERS - ZONE 3 (BUILDING &amp; SITE)</i>	12/02/2024	\$47.00	\$9.65	\$18.40	\$0.00	\$75.05
	06/02/2025	\$48.50	\$9.65	\$18.40	\$0.00	\$76.55
	12/01/2025	\$50.00	\$9.65	\$18.40	\$0.00	\$78.05
	06/01/2026	\$51.55	\$9.65	\$18.40	\$0.00	\$79.60
	12/07/2026	\$53.05	\$9.65	\$18.40	\$0.00	\$81.10
	06/07/2027	\$54.65	\$9.65	\$18.40	\$0.00	\$82.70
	12/06/2027	\$56.25	\$9.65	\$18.40	\$0.00	\$84.30
	06/05/2028	\$57.93	\$9.65	\$18.40	\$0.00	\$85.98
	12/04/2028	\$59.60	\$9.65	\$18.40	\$0.00	\$87.65
For apprentice rates see "Apprentice- LABORER"						
<b>DIVER</b> <i>PILE DRIVER LOCAL 56 (ZONE 3)</i>	08/01/2024	\$78.11	\$10.08	\$24.29	\$0.00	\$112.48
	as of 8-1-24, Apprentices with diving licenses begin at second year. % of Diver wage 70/80/90 2A \$69.83, 3A \$91.79,4A \$102.14 Total Rate					
<b>DIVER TENDER</b> <i>PILE DRIVER LOCAL 56 (ZONE 3)</i>	08/01/2024	\$49.19	\$10.08	\$24.29	\$0.00	\$83.56
	as of 8-1-24, Apprentices with diving licenses begin at second year. % of Piledriver wage 70/80/90 2A \$54.20, 3A \$73.93,4A \$82.05 Total Rate					
<b>DIVER TENDER (EFFLUENT)</b> <i>PILE DRIVER LOCAL 56 (ZONE 3)</i>	08/01/2024	\$83.69	\$10.08	\$24.29	\$0.00	\$118.06
	For apprentice rates see "Apprentice- PILE DRIVER"					
<b>DIVER/SLURRY (EFFLUENT)</b> <i>PILE DRIVER LOCAL 56 (ZONE 3)</i>	08/01/2024	\$117.16	\$10.08	\$24.29	\$0.00	\$151.53
	For apprentice rates see "Apprentice- PILE DRIVER"					
<b>DRAWBRIDGE OPERATOR (Construction)</b> <i>DRAWBRIDGE - SEIU LOCAL 888</i>	07/01/2020	\$26.77	\$6.67	\$3.93	\$0.16	\$37.53
<b>ELECTRICIAN (Including Core Drilling)</b> <i>ELECTRICIANS LOCAL 7</i>	06/30/2024	\$50.01	\$13.00	\$14.86	\$0.00	\$77.87
	12/29/2024	\$51.06	\$13.25	\$15.06	\$0.00	\$79.37
	06/29/2025	\$52.16	\$13.50	\$15.21	\$0.00	\$80.87
	12/28/2025	\$53.26	\$13.75	\$15.36	\$0.00	\$82.37
	06/28/2026	\$54.41	\$14.00	\$15.46	\$0.00	\$83.87
	01/03/2027	\$55.56	\$14.25	\$15.56	\$0.00	\$85.37

**Classification**

**Effective Date    Base Wage    Health    Pension    Supplemental Unemployment    Total Rate**

**Apprentice - ELECTRICIAN - Local 7**

**Effective Date - 06/30/2024**

Step	percent	Apprentice Base Wage	Health	Pension	Supplemental Unemployment	Total Rate
1	40	\$20.00	\$7.20	\$0.60	\$0.00	\$27.80
2	45	\$22.50	\$7.20	\$0.68	\$0.00	\$30.38
3	50	\$25.01	\$13.00	\$7.40	\$0.00	\$45.41
4	55	\$27.51	\$13.00	\$7.48	\$0.00	\$47.99
5	65	\$32.51	\$13.00	\$9.64	\$0.00	\$55.15
6	70	\$35.01	\$13.00	\$11.06	\$0.00	\$59.07

**Effective Date - 12/29/2024**

Step	percent	Apprentice Base Wage	Health	Pension	Supplemental Unemployment	Total Rate
1	40	\$20.42	\$7.35	\$0.61	\$0.00	\$28.38
2	45	\$22.98	\$7.35	\$0.69	\$0.00	\$31.02
3	50	\$25.53	\$13.25	\$7.47	\$0.00	\$46.25
4	55	\$28.08	\$13.25	\$7.54	\$0.00	\$48.87
5	65	\$33.19	\$13.25	\$9.74	\$0.00	\$56.18
6	70	\$35.74	\$13.25	\$11.19	\$0.00	\$60.18

**Notes:**

Steps 1-2 are 1000 hrs; Steps 3-6 are 1500 hrs.

**Apprentice to Journeyworker Ratio:2:3\*\*\*\***

ELEVATOR CONSTRUCTOR	01/01/2024	\$61.98	\$16.18	\$20.96	\$0.00	\$99.12
ELEVATOR CONSTRUCTORS LOCAL 41	01/01/2025	\$62.83	\$16.28	\$21.36	\$0.00	\$100.47
	01/01/2026	\$63.68	\$16.38	\$21.76	\$0.00	\$101.82
	01/01/2027	\$64.53	\$16.48	\$22.16	\$0.00	\$103.17

<b>Classification</b>	<b>Effective Date</b>	<b>Base Wage</b>	<b>Health</b>	<b>Pension</b>	<b>Supplemental Unemployment</b>	<b>Total Rate</b>
-----------------------	-----------------------	------------------	---------------	----------------	----------------------------------	-------------------

**Apprentice - ELEVATOR CONSTRUCTOR - Local 41**

**Effective Date - 01/01/2024**

Step	percent	Apprentice Base Wage	Health	Pension	Supplemental Unemployment	Total Rate
1	50	\$30.99	\$16.18	\$0.00	\$0.00	\$47.17
2	55	\$34.09	\$16.18	\$20.96	\$0.00	\$71.23
3	65	\$40.29	\$16.18	\$20.96	\$0.00	\$77.43
4	70	\$43.39	\$16.18	\$20.96	\$0.00	\$80.53
5	80	\$49.58	\$16.18	\$20.96	\$0.00	\$86.72

**Effective Date - 01/01/2025**

Step	percent	Apprentice Base Wage	Health	Pension	Supplemental Unemployment	Total Rate
1	50	\$31.42	\$16.28	\$0.00	\$0.00	\$47.70
2	55	\$34.56	\$16.28	\$21.36	\$0.00	\$72.20
3	65	\$40.84	\$16.28	\$21.36	\$0.00	\$78.48
4	70	\$43.98	\$16.28	\$21.36	\$0.00	\$81.62
5	80	\$50.26	\$16.28	\$21.36	\$0.00	\$87.90

**Notes:**

Steps 1-2 are 6 mos.; Steps 3-5 are 1 year

**Apprentice to Journeyworker Ratio:1:1**

ELEVATOR CONSTRUCTOR HELPER <i>ELEVATOR CONSTRUCTORS LOCAL 41</i>	01/01/2024	\$43.39	\$16.18	\$20.96	\$0.00	\$80.53
	01/01/2025	\$43.98	\$16.28	\$21.36	\$0.00	\$81.62
	01/01/2026	\$44.58	\$16.38	\$21.76	\$0.00	\$82.72
	01/01/2027	\$45.17	\$16.48	\$22.16	\$0.00	\$83.81

For apprentice rates see "Apprentice - ELEVATOR CONSTRUCTOR"

FENCE & GUARD RAIL ERECTOR (HEAVY & HIGHWAY) <i>LABORERS - ZONE 3 (HEAVY &amp; HIGHWAY)</i>	12/01/2024	\$36.00	\$9.65	\$15.06	\$0.00	\$60.71
	06/01/2025	\$37.25	\$9.65	\$15.06	\$0.00	\$61.96
	12/01/2025	\$38.49	\$9.65	\$15.06	\$0.00	\$63.20
	06/01/2026	\$39.79	\$9.65	\$15.06	\$0.00	\$64.50
	12/01/2026	\$41.08	\$9.65	\$15.06	\$0.00	\$65.79

For apprentice rates see "Apprentice- LABORER (Heavy and Highway)"

FIELD ENG.INST/ROD-BLDG,SITE,HVY/HWY <i>OPERATING ENGINEERS LOCAL 98</i>	06/01/1999	\$18.84	\$4.80	\$4.10	\$0.00	\$27.74
---	------------	---------	--------	--------	--------	---------

FIELD ENG.PARTY CHIEF:BLDG,SITE,HVY/HWY <i>OPERATING ENGINEERS LOCAL 98</i>	06/01/1999	\$21.33	\$4.80	\$4.10	\$0.00	\$30.23
--	------------	---------	--------	--------	--------	---------

FIELD ENG.SURVEY CHIEF-BLDG,SITE,HVY/HWY <i>OPERATING ENGINEERS LOCAL 98</i>	06/01/1999	\$22.33	\$4.80	\$4.10	\$0.00	\$31.23
---	------------	---------	--------	--------	--------	---------

FIRE ALARM INSTALLER <i>ELECTRICIANS LOCAL 7</i>	06/30/2024	\$50.01	\$13.00	\$14.86	\$0.00	\$77.87
	12/29/2024	\$51.06	\$13.25	\$15.06	\$0.00	\$79.37
	06/29/2025	\$52.16	\$13.50	\$15.21	\$0.00	\$80.87
	12/28/2025	\$53.26	\$13.75	\$15.36	\$0.00	\$82.37
	06/28/2026	\$54.41	\$14.00	\$15.46	\$0.00	\$83.87
	01/03/2027	\$55.56	\$14.25	\$15.56	\$0.00	\$85.37

For apprentice rates see "Apprentice- ELECTRICIAN"

Classification	Effective Date	Base Wage	Health	Pension	Supplemental Unemployment	Total Rate
FIRE ALARM REPAIR / MAINTENANCE / COMMISSIONING <i>ELECTRICIANS</i>	06/30/2024	\$50.01	\$13.00	\$14.86	\$0.00	\$77.87
<i>LOCAL 7</i>	12/29/2024	\$51.06	\$13.25	\$15.06	\$0.00	\$79.37
	06/29/2025	\$52.16	\$13.50	\$15.21	\$0.00	\$80.87
	12/28/2025	\$53.26	\$13.75	\$15.36	\$0.00	\$82.37
	06/28/2026	\$54.41	\$14.00	\$15.46	\$0.00	\$83.87
	01/03/2027	\$55.56	\$14.25	\$15.56	\$0.00	\$85.37
For apprentice rates see "Apprentice- TELECOMMUNICATIONS TECHNICIAN"						
FIREMAN <i>OPERATING ENGINEERS LOCAL 98</i>	12/01/2023	\$39.03	\$13.78	\$15.15	\$0.00	\$67.96

**Apprentice - OPERATING ENGINEERS - Local 98 Class 3**

**Effective Date - 12/01/2023**

Step	percent	Apprentice Base Wage	Health	Pension	Supplemental Unemployment	Total Rate
1	60	\$23.42	\$13.78	\$15.15	\$0.00	\$52.35
2	70	\$27.32	\$13.78	\$15.15	\$0.00	\$56.25
3	80	\$31.22	\$13.78	\$15.15	\$0.00	\$60.15
4	90	\$35.13	\$13.78	\$15.15	\$0.00	\$64.06

**Notes:**

Steps 1-2 are 1000 hrs.; Steps 3-4 are 2000 hrs.

**Apprentice to Journeyworker Ratio:1:6**

FLAGGER & SIGNALER (HEAVY & HIGHWAY) <i>LABORERS - ZONE 3 (HEAVY &amp; HIGHWAY)</i>	12/01/2024	\$27.01	\$9.65	\$15.06	\$0.00	\$51.72
	06/01/2025	\$28.09	\$9.65	\$15.06	\$0.00	\$52.80
	12/01/2025	\$28.09	\$9.65	\$15.06	\$0.00	\$52.80
	06/01/2026	\$29.21	\$9.65	\$15.06	\$0.00	\$53.92
	12/01/2026	\$29.21	\$9.65	\$15.06	\$0.00	\$53.92

For apprentice rates see "Apprentice- LABORER (Heavy and Highway)

FLOORCOVERER <i>FLOORCOVERERS LOCAL 2168 ZONE III</i>	09/01/2024	\$42.36	\$7.91	\$18.15	\$0.00	\$68.42
	03/01/2025	\$43.26	\$7.91	\$18.15	\$0.00	\$69.32
	09/01/2025	\$44.21	\$7.91	\$18.15	\$0.00	\$70.27
	03/01/2026	\$45.11	\$7.91	\$18.15	\$0.00	\$71.17
	09/01/2026	\$46.06	\$7.91	\$18.15	\$0.00	\$72.12
	03/01/2027	\$46.96	\$7.91	\$18.15	\$0.00	\$73.02

<b>Classification</b>	<b>Effective Date</b>	<b>Base Wage</b>	<b>Health</b>	<b>Pension</b>	<b>Supplemental Unemployment</b>	<b>Total Rate</b>
-----------------------	-----------------------	------------------	---------------	----------------	----------------------------------	-------------------

**Apprentice - FLOORCOVERER - Local 2168 Zone III**

**Effective Date - 09/01/2024**

Step	percent	Apprentice Base Wage	Health	Pension	Supplemental Unemployment	Total Rate
1	50	\$21.18	\$7.91	\$1.38	\$0.00	\$30.47
2	55	\$23.30	\$7.91	\$1.38	\$0.00	\$32.59
3	60	\$25.42	\$7.91	\$2.76	\$0.00	\$36.09
4	65	\$27.53	\$7.91	\$2.76	\$0.00	\$38.20
5	70	\$29.65	\$7.91	\$15.39	\$0.00	\$52.95
6	75	\$31.77	\$7.91	\$15.39	\$0.00	\$55.07
7	80	\$33.89	\$7.91	\$16.77	\$0.00	\$58.57
8	85	\$36.01	\$7.91	\$16.77	\$0.00	\$60.69

**Effective Date - 03/01/2025**

Step	percent	Apprentice Base Wage	Health	Pension	Supplemental Unemployment	Total Rate
1	50	\$21.63	\$7.91	\$1.38	\$0.00	\$30.92
2	55	\$23.79	\$7.91	\$1.38	\$0.00	\$33.08
3	60	\$25.96	\$7.91	\$2.76	\$0.00	\$36.63
4	65	\$28.12	\$7.91	\$2.76	\$0.00	\$38.79
5	70	\$30.28	\$7.91	\$15.39	\$0.00	\$53.58
6	75	\$32.45	\$7.91	\$15.39	\$0.00	\$55.75
7	80	\$34.61	\$7.91	\$16.77	\$0.00	\$59.29
8	85	\$36.77	\$7.91	\$16.77	\$0.00	\$61.45

**Notes:** Steps are 750 hrs.  
 % After 10/1/17; 45/45/55/55/70/70/80/80 (1500hr Steps)  
 Step 1&2 \$26.72.24/ 3&4 \$32.11/ 5&6 \$50.75/ 7&8 \$56.14

**Apprentice to Journeyworker Ratio:1:1**

<b>FORK LIFT</b> <i>OPERATING ENGINEERS LOCAL 98</i>	12/01/2023	\$39.25	\$13.78	\$15.15	\$0.00	\$68.18
---	------------	---------	---------	---------	--------	---------

For apprentice rates see "Apprentice- OPERATING ENGINEERS"

<b>GENERATORS/LIGHTING PLANTS</b> <i>OPERATING ENGINEERS LOCAL 98</i>	12/01/2023	\$35.80	\$13.78	\$15.15	\$0.00	\$64.73
--	------------	---------	---------	---------	--------	---------

For apprentice rates see "Apprentice- OPERATING ENGINEERS"

<b>GLAZIER (GLASS PLANK/AIR BARRIER/INTERIOR SYSTEMS)</b> <i>GLAZIERS LOCAL 1333</i>	06/01/2020	\$39.18	\$10.80	\$10.45	\$0.00	\$60.43
---	------------	---------	---------	---------	--------	---------

Classification	Effective Date	Base Wage	Health	Pension	Supplemental Unemployment	Total Rate
<b>Apprentice - GLAZIER - Local 1333</b>						
<b>Effective Date - 06/01/2020</b>						
Step	percent	Apprentice Base Wage	Health	Pension	Supplemental Unemployment	Total Rate
1	50	\$19.59	\$10.80	\$1.80	\$0.00	\$32.19
2	56	\$22.04	\$10.80	\$1.80	\$0.00	\$34.64
3	63	\$24.49	\$10.80	\$2.45	\$0.00	\$37.74
4	69	\$26.94	\$10.80	\$2.45	\$0.00	\$40.19
5	75	\$29.39	\$10.80	\$3.15	\$0.00	\$43.34
6	81	\$31.83	\$10.80	\$3.15	\$0.00	\$45.78
7	88	\$34.28	\$10.80	\$10.45	\$0.00	\$55.53
8	94	\$36.73	\$10.80	\$10.45	\$0.00	\$57.98

Notes:

**Apprentice to Journeyworker Ratio:1:3**

GRADER/TRENCHING MACHINE/DERRICK <i>OPERATING ENGINEERS LOCAL 98</i>	12/01/2023	\$39.56	\$13.78	\$15.15	\$0.00	\$68.49
For apprentice rates see "Apprentice- OPERATING ENGINEERS"						
HVAC (DUCTWORK) <i>SHEETMETAL WORKERS LOCAL 63</i>	07/01/2024	\$40.98	\$12.20	\$18.74	\$2.13	\$74.05
	01/01/2025	\$42.23	\$12.20	\$18.74	\$2.13	\$75.30
For apprentice rates see "Apprentice- SHEET METAL WORKER"						
HVAC (ELECTRICAL CONTROLS) <i>ELECTRICIANS LOCAL 7</i>	06/30/2024	\$50.01	\$13.00	\$14.86	\$0.00	\$77.87
	12/29/2024	\$51.06	\$13.25	\$15.06	\$0.00	\$79.37
	06/29/2025	\$52.16	\$13.50	\$15.21	\$0.00	\$80.87
	12/28/2025	\$53.26	\$13.75	\$15.36	\$0.00	\$82.37
	06/28/2026	\$54.41	\$14.00	\$15.46	\$0.00	\$83.87
	01/03/2027	\$55.56	\$14.25	\$15.56	\$0.00	\$85.37
For apprentice rates see "Apprentice- ELECTRICIAN"						
HVAC (TESTING AND BALANCING - AIR) <i>SHEETMETAL WORKERS LOCAL 63</i>	07/01/2024	\$40.98	\$12.20	\$18.74	\$2.13	\$74.05
	01/01/2025	\$42.23	\$12.20	\$18.74	\$2.13	\$75.30
For apprentice rates see "Apprentice- SHEET METAL WORKER"						
HVAC (TESTING AND BALANCING - WATER) <i>PLUMBERS &amp; PIPEFITTERS LOCAL 104</i>	03/17/2024	\$49.21	\$9.55	\$17.10	\$0.00	\$75.86
For apprentice rates see "Apprentice- PIPEFITTER" or "PLUMBER/PIPEFITTER"						
HVAC MECHANIC <i>PLUMBERS &amp; PIPEFITTERS LOCAL 104</i>	03/17/2024	\$49.21	\$9.55	\$17.10	\$0.00	\$75.86
For apprentice rates see "Apprentice- PIPEFITTER" or "PLUMBER/PIPEFITTER"						
HYDRAULIC DRILLS (HEAVY & HIGHWAY) <i>LABORERS - ZONE 3 (HEAVY &amp; HIGHWAY)</i>	12/01/2024	\$36.50	\$9.65	\$15.06	\$0.00	\$61.21
	06/01/2025	\$37.75	\$9.65	\$15.06	\$0.00	\$62.46
	12/01/2025	\$38.99	\$9.65	\$15.06	\$0.00	\$63.70
	06/01/2026	\$40.29	\$9.65	\$15.06	\$0.00	\$65.00
	12/01/2026	\$41.58	\$9.65	\$15.06	\$0.00	\$66.29
For apprentice rates see "Apprentice- LABORER (Heavy and Highway)"						



Classification	Effective Date	Base Wage	Health	Pension	Supplemental Unemployment	Total Rate
INSULATOR (PIPES & TANKS) <i>HEAT &amp; FROST INSULATORS LOCAL 6 (SPRINGFIELD)</i>	09/01/2024	\$45.54	\$14.75	\$19.61	\$0.00	\$79.90
	09/01/2025	\$48.27	\$14.75	\$19.61	\$0.00	\$82.63
	09/01/2026	\$51.01	\$14.75	\$19.61	\$0.00	\$85.37

**Apprentice - ASBESTOS INSULATOR (Pipes & Tanks) - Local 6 Springfield**

**Effective Date - 09/01/2024**

Step	percent	Apprentice Base Wage	Health	Pension	Supplemental Unemployment	Total Rate
1	50	\$22.77	\$14.75	\$14.32	\$0.00	\$51.84
2	60	\$27.32	\$14.75	\$15.37	\$0.00	\$57.44
3	70	\$31.88	\$14.75	\$16.43	\$0.00	\$63.06
4	80	\$36.43	\$14.75	\$17.49	\$0.00	\$68.67

**Effective Date - 09/01/2025**

Step	percent	Apprentice Base Wage	Health	Pension	Supplemental Unemployment	Total Rate
1	50	\$24.14	\$14.75	\$14.32	\$0.00	\$53.21
2	60	\$28.96	\$14.75	\$15.37	\$0.00	\$59.08
3	70	\$33.79	\$14.75	\$16.43	\$0.00	\$64.97
4	80	\$38.62	\$14.75	\$17.49	\$0.00	\$70.86

**Notes:**

Steps are 1 year

**Apprentice to Journeyworker Ratio:1:4**

IRONWORKER/WELDER <i>IRONWORKERS LOCAL 7 (SPRINGFIELD AREA)</i>	03/16/2024	\$40.66	\$8.25	\$22.70	\$0.00	\$71.61
--	------------	---------	--------	---------	--------	---------

**Apprentice - IRONWORKER - Local 7 Springfield**

**Effective Date - 03/16/2024**

Step	percent	Apprentice Base Wage	Health	Pension	Supplemental Unemployment	Total Rate
1	60	\$24.40	\$8.25	\$22.70	\$0.00	\$55.35
2	70	\$28.46	\$8.25	\$22.70	\$0.00	\$59.41
3	75	\$30.50	\$8.25	\$22.70	\$0.00	\$61.45
4	80	\$32.53	\$8.25	\$22.70	\$0.00	\$63.48
5	85	\$34.56	\$8.25	\$22.70	\$0.00	\$65.51
6	90	\$36.59	\$8.25	\$22.70	\$0.00	\$67.54

**Notes:**

**Apprentice to Journeyworker Ratio:1:4**

Classification	Effective Date	Base Wage	Health	Pension	Supplemental Unemployment	Total Rate
JACKHAMMER & PAVING BREAKER OPERATOR <i>LABORERS - ZONE 3 (BUILDING &amp; SITE)</i>	12/02/2024	\$36.00	\$9.65	\$17.07	\$0.00	\$62.72
	06/02/2025	\$37.25	\$9.65	\$17.07	\$0.00	\$63.97
	12/01/2025	\$38.50	\$9.65	\$17.07	\$0.00	\$65.22
	06/01/2026	\$39.80	\$9.65	\$17.07	\$0.00	\$66.52
	12/07/2026	\$41.10	\$9.65	\$17.07	\$0.00	\$67.82
	06/07/2027	\$42.50	\$9.65	\$17.07	\$0.00	\$69.22
	12/06/2027	\$43.90	\$9.65	\$17.07	\$0.00	\$70.62
	06/05/2028	\$45.40	\$9.65	\$17.07	\$0.00	\$72.12
	12/04/2028	\$46.90	\$9.65	\$17.07	\$0.00	\$73.62

For apprentice rates see "Apprentice- LABORER"

LABORER <i>LABORERS - ZONE 3 (BUILDING &amp; SITE)</i>	12/02/2024	\$35.75	\$9.65	\$17.07	\$0.00	\$62.47
	06/02/2025	\$37.00	\$9.65	\$17.07	\$0.00	\$63.72
	12/01/2025	\$38.25	\$9.65	\$17.07	\$0.00	\$64.97
	06/01/2026	\$39.55	\$9.65	\$17.07	\$0.00	\$66.27
	12/07/2026	\$40.85	\$9.65	\$17.07	\$0.00	\$67.57
	06/07/2027	\$42.25	\$9.65	\$17.07	\$0.00	\$68.97
	12/06/2027	\$43.65	\$9.65	\$17.07	\$0.00	\$70.37
	06/05/2028	\$45.15	\$9.65	\$17.07	\$0.00	\$71.87
	12/04/2028	\$46.65	\$9.65	\$17.07	\$0.00	\$73.37

**Apprentice - LABORER - Zone 3 Building & Site**

**Effective Date - 12/02/2024**

Step	percent	Apprentice Base Wage	Health	Pension	Supplemental Unemployment	Total Rate
1	60	\$21.45	\$9.65	\$17.07	\$0.00	\$48.17
2	70	\$25.03	\$9.65	\$17.07	\$0.00	\$51.75
3	80	\$28.60	\$9.65	\$17.07	\$0.00	\$55.32
4	90	\$32.18	\$9.65	\$17.07	\$0.00	\$58.90

**Effective Date - 06/02/2025**

Step	percent	Apprentice Base Wage	Health	Pension	Supplemental Unemployment	Total Rate
1	60	\$22.20	\$9.65	\$17.07	\$0.00	\$48.92
2	70	\$25.90	\$9.65	\$17.07	\$0.00	\$52.62
3	80	\$29.60	\$9.65	\$17.07	\$0.00	\$56.32
4	90	\$33.30	\$9.65	\$17.07	\$0.00	\$60.02

**Notes:**

**Apprentice to Journeyworker Ratio:1:5**

LABORER (HEAVY & HIGHWAY) <i>LABORERS - ZONE 3 (HEAVY &amp; HIGHWAY)</i>	12/01/2024	\$35.75	\$9.65	\$15.06	\$0.00	\$60.46
	06/01/2025	\$37.00	\$9.65	\$15.06	\$0.00	\$61.71
	12/01/2025	\$38.24	\$9.65	\$15.06	\$0.00	\$62.95
	06/01/2026	\$39.54	\$9.65	\$15.06	\$0.00	\$64.25
	12/01/2026	\$40.83	\$9.65	\$15.06	\$0.00	\$65.54

**Classification**

**Effective Date    Base Wage    Health    Pension    Supplemental Unemployment    Total Rate**

**Apprentice - LABORER (Heavy & Highway) - Zone 3**

**Effective Date - 12/01/2024**

Step	percent	Apprentice Base Wage	Health	Pension	Supplemental Unemployment	Total Rate
1	60	\$21.45	\$9.65	\$15.06	\$0.00	\$46.16
2	70	\$25.03	\$9.65	\$15.06	\$0.00	\$49.74
3	80	\$28.60	\$9.65	\$15.06	\$0.00	\$53.31
4	90	\$32.18	\$9.65	\$15.06	\$0.00	\$56.89

**Effective Date - 06/01/2025**

Step	percent	Apprentice Base Wage	Health	Pension	Supplemental Unemployment	Total Rate
1	60	\$22.20	\$9.65	\$15.06	\$0.00	\$46.91
2	70	\$25.90	\$9.65	\$15.06	\$0.00	\$50.61
3	80	\$29.60	\$9.65	\$15.06	\$0.00	\$54.31
4	90	\$33.30	\$9.65	\$15.06	\$0.00	\$58.01

**Notes:**

**Apprentice to Journeyworker Ratio:1:5**

LABORER: CARPENTER TENDER LABORERS - ZONE 3 (BUILDING & SITE)	12/02/2024	\$35.75	\$9.65	\$17.07	\$0.00	\$62.47
	06/02/2025	\$37.00	\$9.65	\$17.07	\$0.00	\$63.72
	12/01/2025	\$38.25	\$9.65	\$17.07	\$0.00	\$64.97
	06/01/2026	\$39.55	\$9.65	\$17.07	\$0.00	\$66.27
	12/07/2026	\$40.85	\$9.65	\$17.07	\$0.00	\$67.57
	06/07/2027	\$42.25	\$9.65	\$17.07	\$0.00	\$68.97
	12/06/2027	\$43.65	\$9.65	\$17.07	\$0.00	\$70.37
	06/05/2028	\$45.15	\$9.65	\$17.07	\$0.00	\$71.87
	12/04/2028	\$46.65	\$9.65	\$17.07	\$0.00	\$73.37

For apprentice rates see "Apprentice- LABORER"

LABORER: CEMENT FINISHER TENDER LABORERS - ZONE 3 (BUILDING & SITE)	12/02/2024	\$35.75	\$9.65	\$17.07	\$0.00	\$62.47
	06/02/2025	\$37.00	\$9.65	\$17.07	\$0.00	\$63.72
	12/01/2025	\$38.25	\$9.65	\$17.07	\$0.00	\$64.97
	06/01/2026	\$39.55	\$9.65	\$17.07	\$0.00	\$66.27
	12/07/2026	\$40.85	\$9.65	\$17.07	\$0.00	\$67.57
	06/07/2027	\$42.25	\$9.65	\$17.07	\$0.00	\$68.97
	12/06/2027	\$43.65	\$9.65	\$17.07	\$0.00	\$70.37
	06/05/2028	\$45.15	\$9.65	\$17.07	\$0.00	\$71.87
	12/04/2028	\$46.65	\$9.65	\$17.07	\$0.00	\$73.37

For apprentice rates see "Apprentice- LABORER"

Classification	Effective Date	Base Wage	Health	Pension	Supplemental Unemployment	Total Rate
LABORER: HAZARDOUS WASTE/ASBESTOS REMOVER <i>LABORERS - ZONE 3 (BUILDING &amp; SITE)</i>	12/02/2024	\$35.67	\$9.65	\$17.20	\$0.00	\$62.52
	06/02/2025	\$36.92	\$9.65	\$17.20	\$0.00	\$63.77
	12/01/2025	\$38.17	\$9.65	\$17.20	\$0.00	\$65.02
	06/01/2026	\$39.47	\$9.65	\$17.20	\$0.00	\$66.32
	12/07/2026	\$40.77	\$9.65	\$17.20	\$0.00	\$67.62
	06/07/2027	\$42.17	\$9.65	\$17.20	\$0.00	\$69.02
	12/06/2027	\$43.57	\$9.65	\$17.20	\$0.00	\$70.42
	06/05/2028	\$45.07	\$9.65	\$17.20	\$0.00	\$71.92
	12/04/2028	\$46.57	\$9.65	\$17.20	\$0.00	\$73.42
For apprentice rates see "Apprentice- LABORER"						
LABORER: MASON TENDER <i>LABORERS - ZONE 3 (BUILDING &amp; SITE)</i>	12/02/2024	\$38.75	\$9.65	\$17.07	\$0.00	\$65.47
	06/02/2025	\$40.00	\$9.65	\$17.07	\$0.00	\$66.72
	12/01/2025	\$41.25	\$9.65	\$17.07	\$0.00	\$67.97
	06/01/2026	\$42.55	\$9.65	\$17.07	\$0.00	\$69.27
	12/07/2026	\$43.85	\$9.65	\$17.07	\$0.00	\$70.57
	06/07/2027	\$45.25	\$9.65	\$17.07	\$0.00	\$71.97
	12/06/2027	\$46.65	\$9.65	\$17.07	\$0.00	\$73.37
	06/05/2028	\$48.15	\$9.65	\$17.07	\$0.00	\$74.87
	12/04/2028	\$49.65	\$9.65	\$17.07	\$0.00	\$76.37
For apprentice rates see "Apprentice- LABORER"						
LABORER: MASON TENDER (HEAVY & HIGHWAY) <i>LABORERS - ZONE 3 (HEAVY &amp; HIGHWAY)</i>	12/01/2024	\$36.00	\$9.65	\$15.06	\$0.00	\$60.71
	06/01/2025	\$37.25	\$9.65	\$15.06	\$0.00	\$61.96
	12/01/2025	\$38.49	\$9.65	\$15.06	\$0.00	\$63.20
	06/01/2026	\$39.79	\$9.65	\$15.06	\$0.00	\$64.50
	12/01/2026	\$41.08	\$9.65	\$15.06	\$0.00	\$65.79
For apprentice rates see "Apprentice- LABORER (Heavy and Highway)"						
LABORER: MULTI-TRADE TENDER <i>LABORERS - ZONE 3 (BUILDING &amp; SITE)</i>	12/02/2024	\$35.75	\$9.65	\$17.07	\$0.00	\$62.47
	06/02/2025	\$37.00	\$9.65	\$17.07	\$0.00	\$63.72
	12/01/2025	\$38.25	\$9.65	\$17.07	\$0.00	\$64.97
	06/01/2026	\$39.55	\$9.65	\$17.07	\$0.00	\$66.27
	12/07/2026	\$40.85	\$9.65	\$17.07	\$0.00	\$67.57
	06/07/2027	\$42.25	\$9.65	\$17.07	\$0.00	\$68.97
	12/06/2027	\$43.65	\$9.65	\$17.07	\$0.00	\$70.37
	06/05/2028	\$45.15	\$9.65	\$17.07	\$0.00	\$71.87
	12/04/2028	\$46.65	\$9.65	\$17.07	\$0.00	\$73.37
For apprentice rates see "Apprentice- LABORER"						
LABORER: TREE REMOVER <i>LABORERS - ZONE 3 (BUILDING &amp; SITE)</i>	12/02/2024	\$35.75	\$9.65	\$17.07	\$0.00	\$62.47
	06/02/2025	\$37.00	\$9.65	\$17.07	\$0.00	\$63.72
	12/01/2025	\$38.25	\$9.65	\$17.07	\$0.00	\$64.97
	06/01/2026	\$39.55	\$9.65	\$17.07	\$0.00	\$66.27
	12/07/2026	\$40.85	\$9.65	\$17.07	\$0.00	\$67.57
	06/07/2027	\$42.25	\$9.65	\$17.07	\$0.00	\$68.97
	12/06/2027	\$43.65	\$9.65	\$17.07	\$0.00	\$70.37
	06/05/2028	\$45.15	\$9.65	\$17.07	\$0.00	\$71.87
	12/04/2028	\$46.65	\$9.65	\$17.07	\$0.00	\$73.37

This classification applies to the removal of standing trees, and the trimming and removal of branches and limbs when related to public works construction or site clearance incidental to construction . For apprentice rates see "Apprentice- LABORER"

Classification	Effective Date	Base Wage	Health	Pension	Supplemental Unemployment	Total Rate
LASER BEAM OPERATOR <i>LABORERS - ZONE 3 (BUILDING &amp; SITE)</i>	12/02/2024	\$36.00	\$9.65	\$17.07	\$0.00	\$62.72
	06/02/2025	\$37.25	\$9.65	\$17.07	\$0.00	\$63.97
	12/01/2025	\$38.50	\$9.65	\$17.07	\$0.00	\$65.22
	06/01/2026	\$39.80	\$9.65	\$17.07	\$0.00	\$66.52
	12/07/2026	\$41.10	\$9.65	\$17.07	\$0.00	\$67.82
	06/07/2027	\$42.50	\$9.65	\$17.07	\$0.00	\$69.22
	12/06/2027	\$43.90	\$9.65	\$17.07	\$0.00	\$70.62
	06/05/2028	\$45.40	\$9.65	\$17.07	\$0.00	\$72.12
	12/04/2028	\$46.90	\$9.65	\$17.07	\$0.00	\$73.62

For apprentice rates see "Apprentice- LABORER"

LASER BEAM OPERATOR (HEAVY & HIGHWAY) <i>LABORERS - ZONE 3 (HEAVY &amp; HIGHWAY)</i>	12/01/2024	\$36.00	\$9.65	\$15.06	\$0.00	\$60.71
	06/01/2025	\$37.25	\$9.65	\$15.06	\$0.00	\$61.96
	12/01/2025	\$38.49	\$9.65	\$15.06	\$0.00	\$63.20
	06/01/2026	\$39.79	\$9.65	\$15.06	\$0.00	\$64.50
	12/01/2026	\$41.08	\$9.65	\$15.06	\$0.00	\$65.79

For apprentice rates see "Apprentice- LABORER (Heavy and Highway)"

MARBLE & TILE FINISHERS <i>BRICKLAYERS LOCAL 3 (SPR/PITT) - MARBLE &amp; TILE</i>	08/01/2024	\$43.05	\$11.49	\$20.53	\$0.00	\$75.07
	02/01/2025	\$44.90	\$11.49	\$20.53	\$0.00	\$76.92
	08/01/2025	\$45.81	\$11.49	\$20.53	\$0.00	\$77.83
	02/01/2026	\$46.89	\$11.49	\$20.53	\$0.00	\$78.91
	08/01/2026	\$48.65	\$11.49	\$20.53	\$0.00	\$80.67
	02/01/2027	\$49.77	\$11.49	\$20.53	\$0.00	\$81.79

**Apprentice - MARBLE-TILE FINISHER-Local 3 Marble/Tile (Spr/Pitt)**

**Effective Date - 08/01/2024**

Step	percent	Apprentice Base Wage	Health	Pension	Supplemental Unemployment	Total Rate
1	50	\$21.53	\$11.49	\$20.53	\$0.00	\$53.55
2	60	\$25.83	\$11.49	\$20.53	\$0.00	\$57.85
3	70	\$30.14	\$11.49	\$20.53	\$0.00	\$62.16
4	80	\$34.44	\$11.49	\$20.53	\$0.00	\$66.46
5	90	\$38.75	\$11.49	\$20.53	\$0.00	\$70.77

**Effective Date - 02/01/2025**

Step	percent	Apprentice Base Wage	Health	Pension	Supplemental Unemployment	Total Rate
1	50	\$22.45	\$11.49	\$20.53	\$0.00	\$54.47
2	60	\$26.94	\$11.49	\$20.53	\$0.00	\$58.96
3	70	\$31.43	\$11.49	\$20.53	\$0.00	\$63.45
4	80	\$35.92	\$11.49	\$20.53	\$0.00	\$67.94
5	90	\$40.41	\$11.49	\$20.53	\$0.00	\$72.43

**Notes:**

**Apprentice to Journeyworker Ratio:1:5**

MARBLE MASON/TILE LAYER(SP/PT)SeeBrick  
*BRICKLAYERS LOCAL 3 (SPR/PITT) - MARBLE & TILE*

Classification	Effective Date	Base Wage	Health	Pension	Supplemental Unemployment	Total Rate
See "BRICK/STONE/ARTIFICIAL MASONRY(INCL.MASONRY WATERPROOFING)						
MECH. SWEEPER OPERATOR (ON CONST. SITES) <i>OPERATING ENGINEERS LOCAL 98</i>	12/01/2023	\$39.56	\$13.78	\$15.15	\$0.00	\$68.49
For apprentice rates see "Apprentice- OPERATING ENGINEERS"						
MECHANIC/WELDER/BOOM TRUCK <i>OPERATING ENGINEERS LOCAL 98</i>	12/01/2023	\$39.03	\$13.78	\$15.15	\$0.00	\$67.96
For apprentice rates see "Apprentice- OPERATING ENGINEERS"						
MILLWRIGHT (Zone 3) <i>MILLWRIGHTS LOCAL 1121 - Zone 3</i>	01/01/2024	\$41.20	\$10.08	\$21.22	\$0.00	\$72.50
	01/06/2025	\$43.48	\$10.08	\$21.22	\$0.00	\$74.78
	01/05/2026	\$45.76	\$10.08	\$21.22	\$0.00	\$77.06

**Apprentice - MILLWRIGHT - Local 1121 Zone 3**

**Effective Date - 01/01/2024**

Step	percent	Apprentice Base Wage	Health	Pension	Supplemental Unemployment	Total Rate
1	55	\$22.66	\$10.08	\$5.36	\$0.00	\$38.10
2	65	\$26.78	\$10.08	\$6.34	\$0.00	\$43.20
3	75	\$30.90	\$10.08	\$18.78	\$0.00	\$59.76
4	85	\$35.02	\$10.08	\$19.76	\$0.00	\$64.86

**Effective Date - 01/06/2025**

Step	percent	Apprentice Base Wage	Health	Pension	Supplemental Unemployment	Total Rate
1	55	\$23.91	\$10.08	\$5.36	\$0.00	\$39.35
2	65	\$28.26	\$10.08	\$6.34	\$0.00	\$44.68
3	75	\$32.61	\$10.08	\$18.78	\$0.00	\$61.47
4	85	\$36.96	\$10.08	\$19.76	\$0.00	\$66.80

**Notes:** Step 1&2 Appr. indentured after 1/6/2020 receive no pension, but do receive annuity. (Step 1 \$5.72, Step 2 \$6.66)  
Steps are 2,000 hours

**Apprentice to Journeyworker Ratio:1:4**

MORTAR MIXER <i>LABORERS - ZONE 3 (BUILDING &amp; SITE)</i>	12/02/2024	\$36.00	\$9.65	\$17.07	\$0.00	\$62.72
	06/02/2025	\$37.25	\$9.65	\$17.07	\$0.00	\$63.97
	12/01/2025	\$38.50	\$9.65	\$17.07	\$0.00	\$65.22
	06/01/2026	\$39.80	\$9.65	\$17.07	\$0.00	\$66.52
	12/07/2026	\$41.10	\$9.65	\$17.07	\$0.00	\$67.82
	06/07/2027	\$42.50	\$9.65	\$17.07	\$0.00	\$69.22
	12/06/2027	\$43.90	\$9.65	\$17.07	\$0.00	\$70.62
	06/05/2028	\$45.40	\$9.65	\$17.07	\$0.00	\$72.12
	12/04/2028	\$46.90	\$9.65	\$17.07	\$0.00	\$73.62
For apprentice rates see "Apprentice- LABORER"						
OILER <i>OPERATING ENGINEERS LOCAL 98</i>	12/01/2023	\$35.02	\$13.78	\$15.15	\$0.00	\$63.95
For apprentice rates see "Apprentice- OPERATING ENGINEERS"						
OTHER POWER DRIVEN EQUIPMENT - CLASS VI <i>OPERATING ENGINEERS LOCAL 98</i>	12/01/2023	\$32.74	\$13.78	\$15.15	\$0.00	\$61.67
For apprentice rates see "Apprentice- OPERATING ENGINEERS"						
Painter (BRIDGES/TANKS) <i>PAINTERS LOCAL 35 - ZONE 3</i>	07/01/2024	\$57.26	\$9.95	\$23.95	\$0.00	\$91.16
	01/01/2025	\$58.46	\$9.95	\$23.95	\$0.00	\$92.36

**Classification**

**Effective Date    Base Wage    Health    Pension    Supplemental Unemployment    Total Rate**

**Apprentice - PAINTER Local 35 - BRIDGES/TANKS**

**Effective Date - 07/01/2024**

Step	percent	Apprentice Base Wage	Health	Pension	Supplemental Unemployment	Total Rate
1	50	\$28.63	\$9.95	\$0.00	\$0.00	\$38.58
2	55	\$31.49	\$9.95	\$6.66	\$0.00	\$48.10
3	60	\$34.36	\$9.95	\$7.26	\$0.00	\$51.57
4	65	\$37.22	\$9.95	\$7.87	\$0.00	\$55.04
5	70	\$40.08	\$9.95	\$20.32	\$0.00	\$70.35
6	75	\$42.95	\$9.95	\$20.93	\$0.00	\$73.83
7	80	\$45.81	\$9.95	\$21.53	\$0.00	\$77.29
8	90	\$51.53	\$9.95	\$22.74	\$0.00	\$84.22

**Effective Date - 01/01/2025**

Step	percent	Apprentice Base Wage	Health	Pension	Supplemental Unemployment	Total Rate
1	50	\$29.23	\$9.95	\$0.00	\$0.00	\$39.18
2	55	\$32.15	\$9.95	\$6.66	\$0.00	\$48.76
3	60	\$35.08	\$9.95	\$7.26	\$0.00	\$52.29
4	65	\$38.00	\$9.95	\$7.87	\$0.00	\$55.82
5	70	\$40.92	\$9.95	\$20.32	\$0.00	\$71.19
6	75	\$43.85	\$9.95	\$20.93	\$0.00	\$74.73
7	80	\$46.77	\$9.95	\$21.53	\$0.00	\$78.25
8	90	\$52.61	\$9.95	\$22.74	\$0.00	\$85.30

**Notes:**

Steps are 750 hrs.

**Apprentice to Journeyworker Ratio:1:1**

PAINTER (SPRAY OR SANDBLAST, NEW) *	07/01/2024	\$40.03	\$9.65	\$19.90	\$0.00	\$69.58
* If 30% or more of surfaces to be painted are new construction, NEW paint rate shall be used. PAINTERS LOCAL 35 - ZONE 3	01/01/2025	\$41.23	\$9.65	\$19.90	\$0.00	\$70.78

**Classification**

**Effective Date    Base Wage    Health    Pension    Supplemental Unemployment    Total Rate**

**Apprentice - PAINTER Local 35 Zone 3 - Spray/Sandblast - New**

**Effective Date - 07/01/2024**

Step	percent	Apprentice Base Wage	Health	Pension	Supplemental Unemployment	Total Rate
1	50	\$20.02	\$9.95	\$0.00	\$0.00	\$29.97
2	55	\$22.02	\$9.95	\$4.43	\$0.00	\$36.40
3	60	\$24.02	\$9.95	\$4.83	\$0.00	\$38.80
4	65	\$26.02	\$9.95	\$5.23	\$0.00	\$41.20
5	70	\$28.02	\$9.95	\$17.49	\$0.00	\$55.46
6	75	\$30.02	\$9.95	\$17.89	\$0.00	\$57.86
7	80	\$32.02	\$9.95	\$18.29	\$0.00	\$60.26
8	90	\$36.03	\$9.95	\$19.10	\$0.00	\$65.08

**Effective Date - 01/01/2025**

Step	percent	Apprentice Base Wage	Health	Pension	Supplemental Unemployment	Total Rate
1	50	\$20.62	\$9.95	\$0.00	\$0.00	\$30.57
2	55	\$22.68	\$9.95	\$4.43	\$0.00	\$37.06
3	60	\$24.74	\$9.95	\$4.83	\$0.00	\$39.52
4	65	\$26.80	\$9.95	\$5.23	\$0.00	\$41.98
5	70	\$28.86	\$9.95	\$17.49	\$0.00	\$56.30
6	75	\$30.92	\$9.95	\$17.89	\$0.00	\$58.76
7	80	\$32.98	\$9.95	\$18.29	\$0.00	\$61.22
8	90	\$37.11	\$9.95	\$19.10	\$0.00	\$66.16

**Notes:**  
Steps are 750 hrs.

**Apprentice to Journeyworker Ratio:1:1**

PAINTER (SPRAY OR SANDBLAST, REPAINT)	07/01/2024	\$37.35	\$9.95	\$19.90	\$0.00	\$67.20
PAINTERS LOCAL 35 - ZONE 3	01/01/2025	\$38.55	\$9.95	\$19.90	\$0.00	\$68.40



**Classification**

**Effective Date    Base Wage    Health    Pension    Supplemental Unemployment    Total Rate**

**Apprentice - PAINTER Local 35 Zone 3 - Spray/Sandblast - Repaint**

**Effective Date - 07/01/2024**

Step	percent	Apprentice Base Wage	Health	Pension	Supplemental Unemployment	Total Rate
1	50	\$18.68	\$9.95	\$0.00	\$0.00	\$28.63
2	55	\$20.54	\$9.95	\$4.43	\$0.00	\$34.92
3	60	\$22.41	\$9.95	\$4.83	\$0.00	\$37.19
4	65	\$24.28	\$9.95	\$5.23	\$0.00	\$39.46
5	70	\$26.15	\$9.95	\$17.49	\$0.00	\$53.59
6	75	\$28.01	\$9.95	\$17.89	\$0.00	\$55.85
7	80	\$29.88	\$9.95	\$18.29	\$0.00	\$58.12
8	90	\$33.62	\$9.95	\$19.10	\$0.00	\$62.67

**Effective Date - 01/01/2025**

Step	percent	Apprentice Base Wage	Health	Pension	Supplemental Unemployment	Total Rate
1	50	\$19.28	\$9.95	\$0.00	\$0.00	\$29.23
2	55	\$21.20	\$9.95	\$4.43	\$0.00	\$35.58
3	60	\$23.13	\$9.95	\$4.83	\$0.00	\$37.91
4	65	\$25.06	\$9.95	\$5.23	\$0.00	\$40.24
5	70	\$26.99	\$9.95	\$17.49	\$0.00	\$54.43
6	75	\$28.91	\$9.95	\$17.89	\$0.00	\$56.75
7	80	\$30.84	\$9.95	\$18.29	\$0.00	\$59.08
8	90	\$34.70	\$9.95	\$19.10	\$0.00	\$63.75

**Notes:**

Steps are 750 hrs.

**Apprentice to Journeyworker Ratio:1:1**

PAINTER / TAPER (BRUSH, NEW) *	07/01/2024	\$38.63	\$9.95	\$19.90	\$0.00	\$68.48
* If 30% or more of surfaces to be painted are new construction, NEW paint rate shall be used. PAINTERS LOCAL 35 - ZONE 3	01/01/2025	\$39.83	\$9.95	\$19.90	\$0.00	\$69.68

**Classification**

**Effective Date    Base Wage    Health    Pension    Supplemental Unemployment    Total Rate**

**Apprentice - PAINTER - Local 35 Zone 3 - BRUSH NEW**

**Effective Date - 07/01/2024**

Step	percent	Apprentice Base Wage	Health	Pension	Supplemental Unemployment	Total Rate
1	50	\$19.32	\$9.95	\$0.00	\$0.00	\$29.27
2	55	\$21.25	\$9.95	\$4.43	\$0.00	\$35.63
3	60	\$23.18	\$9.95	\$4.83	\$0.00	\$37.96
4	65	\$25.11	\$9.95	\$5.23	\$0.00	\$40.29
5	70	\$27.04	\$9.95	\$17.49	\$0.00	\$54.48
6	75	\$28.97	\$9.95	\$17.89	\$0.00	\$56.81
7	80	\$30.90	\$9.95	\$18.29	\$0.00	\$59.14
8	90	\$34.77	\$9.95	\$19.10	\$0.00	\$63.82

**Effective Date - 01/01/2025**

Step	percent	Apprentice Base Wage	Health	Pension	Supplemental Unemployment	Total Rate
1	50	\$19.92	\$9.95	\$0.00	\$0.00	\$29.87
2	55	\$21.91	\$9.95	\$4.43	\$0.00	\$36.29
3	60	\$23.90	\$9.95	\$4.83	\$0.00	\$38.68
4	65	\$25.89	\$9.95	\$5.23	\$0.00	\$41.07
5	70	\$27.88	\$9.95	\$17.49	\$0.00	\$55.32
6	75	\$29.87	\$9.95	\$17.89	\$0.00	\$57.71
7	80	\$31.86	\$9.95	\$18.29	\$0.00	\$60.10
8	90	\$35.85	\$9.95	\$19.10	\$0.00	\$64.90

**Notes:**

Steps are 750 hrs.

**Apprentice to Journeyworker Ratio:1:1**

PAINTER / TAPER (BRUSH, REPAINT)	07/01/2024	\$35.95	\$9.95	\$19.90	\$0.00	\$65.80
PAINTERS LOCAL 35 - ZONE 3	01/01/2025	\$37.15	\$9.95	\$19.90	\$0.00	\$67.00

**Classification**

**Effective Date    Base Wage    Health    Pension    Supplemental Unemployment    Total Rate**

**Apprentice - PAINTER Local 35 Zone 3 - BRUSH REPAINT**

**Effective Date - 07/01/2024**

Step	percent	Apprentice Base Wage	Health	Pension	Supplemental Unemployment	Total Rate
1	50	\$17.98	\$9.95	\$0.00	\$0.00	\$27.93
2	55	\$19.77	\$9.95	\$4.43	\$0.00	\$34.15
3	60	\$21.57	\$9.95	\$4.83	\$0.00	\$36.35
4	65	\$23.37	\$9.95	\$5.23	\$0.00	\$38.55
5	70	\$25.17	\$9.95	\$17.49	\$0.00	\$52.61
6	75	\$26.96	\$9.95	\$17.89	\$0.00	\$54.80
7	80	\$28.76	\$9.95	\$18.29	\$0.00	\$57.00
8	90	\$32.36	\$9.95	\$19.10	\$0.00	\$61.41

**Effective Date - 01/01/2025**

Step	percent	Apprentice Base Wage	Health	Pension	Supplemental Unemployment	Total Rate
1	50	\$18.58	\$9.95	\$0.00	\$0.00	\$28.53
2	55	\$20.43	\$9.95	\$4.43	\$0.00	\$34.81
3	60	\$22.29	\$9.95	\$4.83	\$0.00	\$37.07
4	65	\$24.15	\$9.95	\$5.23	\$0.00	\$39.33
5	70	\$26.01	\$9.95	\$17.49	\$0.00	\$53.45
6	75	\$27.86	\$9.95	\$17.89	\$0.00	\$55.70
7	80	\$29.72	\$9.95	\$18.29	\$0.00	\$57.96
8	90	\$33.44	\$9.95	\$19.10	\$0.00	\$62.49

**Notes:**

Steps are 750 hrs.

**Apprentice to Journeyworker Ratio:1:1**

PAINTER TRAFFIC MARKINGS (HEAVY/HIGHWAY) LABORERS - ZONE 3 (HEAVY & HIGHWAY)	12/01/2024	\$35.75	\$9.65	\$15.06	\$0.00	\$60.46
	06/01/2025	\$37.00	\$9.65	\$15.06	\$0.00	\$61.71
	12/01/2025	\$38.24	\$9.65	\$15.06	\$0.00	\$62.95
	06/01/2026	\$39.54	\$9.65	\$15.06	\$0.00	\$64.25
	12/01/2026	\$40.83	\$9.65	\$15.06	\$0.00	\$65.54

For apprentice rates see "Apprentice- LABORER (Heavy and Highway)

PANEL & PICKUP TRUCKS DRIVER TEAMSTERS JOINT COUNCIL NO. 10 ZONE B	12/01/2024	\$39.78	\$15.07	\$20.17	\$0.00	\$75.02
	01/01/2025	\$39.78	\$15.57	\$20.17	\$0.00	\$75.52
	06/01/2025	\$40.78	\$15.57	\$20.17	\$0.00	\$76.52
	12/01/2025	\$40.78	\$15.57	\$21.78	\$0.00	\$78.13
	01/01/2026	\$40.78	\$16.17	\$21.78	\$0.00	\$78.73
	06/01/2026	\$41.78	\$16.17	\$21.78	\$0.00	\$79.73
	12/01/2026	\$41.78	\$16.17	\$23.52	\$0.00	\$81.47
	01/01/2027	\$41.78	\$16.77	\$23.52	\$0.00	\$82.07

PIER AND DOCK CONSTRUCTOR (UNDERPINNING AND DECK) PILE DRIVER LOCAL 56 (ZONE 3)	08/01/2024	\$49.19	\$10.08	\$24.29	\$0.00	\$83.56
--	------------	---------	---------	---------	--------	---------

For apprentice rates see "Apprentice- PILE DRIVER"

Classification	Effective Date	Base Wage	Health	Pension	Supplemental Unemployment	Total Rate
PILE DRIVER <i>PILE DRIVER LOCAL 56 (ZONE 3)</i>	08/01/2024	\$49.19	\$10.08	\$24.29	\$0.00	\$83.56

**Apprentice - PILE DRIVER - Local 56 Zone 3**

**Effective Date - 08/01/2024**

Step	percent	Apprentice Base Wage	Health	Pension	Supplemental Unemployment	Total Rate
1	45	\$22.14	\$10.08	\$2.53	\$0.00	\$34.75
2	55	\$27.05	\$10.08	\$5.07	\$0.00	\$42.20
3	70	\$34.43	\$10.08	\$19.22	\$0.00	\$63.73
4	80	\$39.35	\$10.08	\$21.76	\$0.00	\$71.19

**Notes:**  
 % Indentured BEFORE 8/1/2020, 50/60/70/75/80/80/90/90  
 1\$58.97/2\$63.88/3\$68.80/4\$71.26/5&6 \$73.72/7&8 \$78.64

**Apprentice to Journeyworker Ratio:1:5**

PIPELAYER <i>LABORERS - ZONE 3 (BUILDING &amp; SITE)</i>	12/02/2024	\$36.00	\$9.65	\$17.07	\$0.00	\$62.72
	06/02/2025	\$37.25	\$9.65	\$17.07	\$0.00	\$63.97
	12/01/2025	\$38.50	\$9.65	\$17.07	\$0.00	\$65.22
	06/01/2026	\$39.80	\$9.65	\$17.07	\$0.00	\$66.52
	12/07/2026	\$41.10	\$9.65	\$17.07	\$0.00	\$67.82
	06/07/2027	\$42.50	\$9.65	\$17.07	\$0.00	\$69.22
	12/06/2027	\$43.90	\$9.65	\$17.07	\$0.00	\$70.62
	06/05/2028	\$45.40	\$9.65	\$17.07	\$0.00	\$72.12
	12/04/2028	\$46.90	\$9.65	\$17.07	\$0.00	\$73.62

For apprentice rates see "Apprentice- LABORER"

PIPELAYER (HEAVY & HIGHWAY) <i>LABORERS - ZONE 3 (HEAVY &amp; HIGHWAY)</i>	12/01/2024	\$36.00	\$9.65	\$15.06	\$0.00	\$60.71
	06/01/2025	\$37.25	\$9.65	\$15.06	\$0.00	\$61.96
	12/01/2025	\$38.49	\$9.65	\$15.06	\$0.00	\$63.20
	06/01/2026	\$39.79	\$9.65	\$15.06	\$0.00	\$64.50
	12/01/2026	\$41.08	\$9.65	\$15.06	\$0.00	\$65.79

For apprentice rates see "Apprentice- LABORER (Heavy and Highway)"

PLUMBER & PIPEFITTER <i>PLUMBERS &amp; PIPEFITTERS LOCAL 104</i>	03/17/2024	\$49.21	\$9.55	\$17.10	\$0.00	\$75.86
---	------------	---------	--------	---------	--------	---------

Classification	Effective Date	Base Wage	Health	Pension	Supplemental Unemployment	Total Rate
<b>Apprentice - PLUMBER/PIPEFITTER - Local 104</b>						
<b>Effective Date - 03/17/2024</b>						
Step	percent	Apprentice Base Wage	Health	Pension	Supplemental Unemployment	Total Rate
1	45	\$22.14	\$9.55	\$10.10	\$0.00	\$41.79
2	50	\$24.61	\$9.55	\$10.10	\$0.00	\$44.26
3	55	\$27.07	\$9.55	\$10.10	\$0.00	\$46.72
4	60	\$29.53	\$9.55	\$10.10	\$0.00	\$49.18
5	65	\$31.99	\$9.55	\$10.10	\$0.00	\$51.64
6	70	\$34.45	\$9.55	\$10.10	\$0.00	\$54.10
7	75	\$36.91	\$9.55	\$10.10	\$0.00	\$56.56
8	80	\$39.37	\$9.55	\$10.10	\$0.00	\$59.02
9	80	\$39.37	\$9.55	\$17.10	\$0.00	\$66.02
10	80	\$39.37	\$9.55	\$17.10	\$0.00	\$66.02

Notes: \*\*1:1,2:5,3:9,4:12

**Apprentice to Journeyworker Ratio:\*\***

PNEUMATIC CONTROLS (TEMP.) PLUMBERS & PIPEFITTERS LOCAL 104	03/17/2024	\$49.21	\$9.55	\$17.10	\$0.00	\$75.86
--	------------	---------	--------	---------	--------	---------

For apprentice rates see "Apprentice- PIPEFITTER" or "PLUMBER/PIPEFITTER"

PNEUMATIC DRILL/TOOL OPERATOR (HEAVY & HIGHWAY) LABORERS - ZONE 3 (HEAVY & HIGHWAY)	12/01/2024	\$36.00	\$9.65	\$15.06	\$0.00	\$60.71
	06/01/2025	\$37.25	\$9.65	\$15.06	\$0.00	\$61.96
	12/01/2025	\$38.49	\$9.65	\$15.06	\$0.00	\$63.20
	06/01/2026	\$39.79	\$9.65	\$15.06	\$0.00	\$64.50
	12/01/2026	\$41.08	\$9.65	\$15.06	\$0.00	\$65.79

For apprentice rates see "Apprentice- LABORER (Heavy and Highway)"

POWDERMAN & BLASTER LABORERS - ZONE 3 (BUILDING & SITE)	12/02/2024	\$36.75	\$9.65	\$17.07	\$0.00	\$63.47
	06/02/2025	\$38.00	\$9.65	\$17.07	\$0.00	\$64.72
	12/01/2025	\$39.25	\$9.65	\$17.07	\$0.00	\$65.97
	06/01/2026	\$40.55	\$9.65	\$17.07	\$0.00	\$67.27
	12/07/2026	\$41.85	\$9.65	\$17.07	\$0.00	\$68.57
	06/07/2027	\$43.25	\$9.65	\$17.07	\$0.00	\$69.97
	12/06/2027	\$44.65	\$9.65	\$17.07	\$0.00	\$71.37
	06/05/2028	\$46.15	\$9.65	\$17.07	\$0.00	\$72.87
12/04/2028	\$47.65	\$9.65	\$17.07	\$0.00	\$74.37	

For apprentice rates see "Apprentice- LABORER"

POWDERMAN & BLASTER (HEAVY & HIGHWAY) LABORERS - ZONE 3 (HEAVY & HIGHWAY)	12/01/2024	\$36.75	\$9.65	\$15.06	\$0.00	\$61.46
	06/01/2025	\$38.00	\$9.65	\$15.06	\$0.00	\$62.71
	12/01/2025	\$39.24	\$9.65	\$15.06	\$0.00	\$63.95
	06/01/2026	\$40.54	\$9.65	\$15.06	\$0.00	\$65.25
	12/01/2026	\$41.83	\$9.65	\$15.06	\$0.00	\$66.54

For apprentice rates see "Apprentice- LABORER (Heavy and Highway)"

PUMP OPERATOR (CONCRETE) OPERATING ENGINEERS LOCAL 98	12/01/2023	\$39.56	\$13.78	\$15.15	\$0.00	\$68.49
--	------------	---------	---------	---------	--------	---------

For apprentice rates see "Apprentice- OPERATING ENGINEERS"

Classification	Effective Date	Base Wage	Health	Pension	Supplemental Unemployment	Total Rate
PUMP OPERATOR (DEWATERING, OTHER) <i>OPERATING ENGINEERS LOCAL 98</i>	12/01/2023	\$39.03	\$13.78	\$15.15	\$0.00	\$67.96
For apprentice rates see "Apprentice- OPERATING ENGINEERS"						
READY-MIX CONCRETE DRIVER <i>TEAMSTERS 404 - Construction Service (Northampton)</i>	05/01/2024	\$26.14	\$11.82	\$7.25	\$0.00	\$45.21
RIDE-ON MOTORIZED BUGGY OPERATOR <i>LABORERS - ZONE 3 (BUILDING &amp; SITE)</i>	12/02/2024	\$36.00	\$9.65	\$17.07	\$0.00	\$62.72
	06/02/2025	\$37.25	\$9.65	\$17.07	\$0.00	\$63.97
	12/01/2025	\$38.50	\$9.65	\$17.07	\$0.00	\$65.22
	06/01/2026	\$39.80	\$9.65	\$17.07	\$0.00	\$66.52
	12/07/2026	\$41.10	\$9.65	\$17.07	\$0.00	\$67.82
	06/07/2027	\$42.50	\$9.65	\$17.07	\$0.00	\$69.22
	12/06/2027	\$43.90	\$9.65	\$17.07	\$0.00	\$70.62
	06/05/2028	\$45.40	\$9.65	\$17.07	\$0.00	\$72.12
	12/04/2028	\$46.90	\$9.65	\$17.07	\$0.00	\$73.62
For apprentice rates see "Apprentice- LABORER"						
ROLLER OPERATOR <i>OPERATING ENGINEERS LOCAL 98</i>	12/01/2023	\$38.42	\$13.78	\$15.15	\$0.00	\$67.35
For apprentice rates see "Apprentice- OPERATING ENGINEERS"						
ROOFER (Coal tar pitch) <i>ROOFERS LOCAL 248</i>	10/02/2024	\$42.38	\$10.35	\$18.00	\$0.00	\$70.73
	07/16/2025	\$43.88	\$10.35	\$18.00	\$0.00	\$72.23
	10/02/2025	\$44.88	\$10.35	\$18.00	\$0.00	\$73.23
	07/16/2026	\$46.88	\$10.35	\$18.00	\$0.00	\$75.23
For apprentice rates see "Apprentice- ROOFER"						
ROOFER (Inc.Roofer Waterproofing &Roofer Damproofg) <i>ROOFERS LOCAL 248</i>	10/02/2024	\$41.88	\$10.35	\$18.00	\$0.00	\$70.23
	07/16/2025	\$43.38	\$10.35	\$18.00	\$0.00	\$71.73
	10/02/2025	\$44.38	\$10.35	\$18.00	\$0.00	\$72.73
	07/16/2026	\$46.38	\$10.35	\$18.00	\$0.00	\$74.73

**Apprentice - ROOFER - Local 248**

**Effective Date - 10/02/2024**

Step	percent	Apprentice Base Wage	Health	Pension	Supplemental Unemployment	Total Rate
1	60	\$25.13	\$10.35	\$0.00	\$0.00	\$35.48
2	65	\$27.22	\$10.35	\$18.00	\$0.00	\$55.57
3	70	\$29.32	\$10.35	\$18.00	\$0.00	\$57.67
4	75	\$31.41	\$10.35	\$18.00	\$0.00	\$59.76
5	80	\$33.50	\$10.35	\$18.00	\$0.00	\$61.85
6	85	\$35.60	\$10.35	\$18.00	\$0.00	\$63.95
7	90	\$37.69	\$10.35	\$18.00	\$0.00	\$66.04
8	95	\$39.79	\$10.35	\$18.00	\$0.00	\$68.14

**Notes:**

Steps are 750 hrs.Roofer(Tear Off)1:1; Same as above

**Apprentice to Journeyworker Ratio:1:3**

<b>Classification</b>	<b>Effective Date</b>	<b>Base Wage</b>	<b>Health</b>	<b>Pension</b>	<b>Supplemental Unemployment</b>	<b>Total Rate</b>
ROOFER SLATE / TILE / PRECAST CONCRETE <i>ROOFERS LOCAL 248</i>	10/02/2024	\$42.38	\$10.35	\$18.00	\$0.00	\$70.73
	07/16/2025	\$43.88	\$10.35	\$18.00	\$0.00	\$72.23
	10/02/2025	\$44.88	\$10.35	\$18.00	\$0.00	\$73.23
	07/16/2026	\$46.88	\$10.35	\$18.00	\$0.00	\$75.23
For apprentice rates see "Apprentice- ROOFER"						
SCRAPER <i>OPERATING ENGINEERS LOCAL 98</i>	12/01/2023	\$39.03	\$13.78	\$15.15	\$0.00	\$67.96
For apprentice rates see "Apprentice- OPERATING ENGINEERS"						
SELF-POWERED ROLLERS AND COMPACTORS (TAMPERS) <i>OPERATING ENGINEERS LOCAL 98</i>	12/01/2023	\$38.42	\$13.78	\$15.15	\$0.00	\$67.35
For apprentice rates see "Apprentice- OPERATING ENGINEERS"						
SELF-PROPELLED POWER BROOM <i>OPERATING ENGINEERS LOCAL 98</i>	12/01/2023	\$35.80	\$13.78	\$15.15	\$0.00	\$64.73
For apprentice rates see "Apprentice- OPERATING ENGINEERS"						
SHEETMETAL WORKER <i>SHEETMETAL WORKERS LOCAL 63</i>	07/01/2024	\$40.98	\$12.20	\$18.74	\$2.13	\$74.05
	01/01/2025	\$42.23	\$12.20	\$18.74	\$2.13	\$75.30

**Classification**

**Effective Date    Base Wage    Health    Pension    Supplemental Unemployment    Total Rate**

**Apprentice - SHEET METAL WORKER - Local 63**

**Effective Date - 07/01/2024**

Step	percent	Apprentice Base Wage	Health	Pension	Supplemental Unemployment	Total Rate
1	45	\$18.44	\$5.49	\$4.86	\$0.85	\$29.64
2	50	\$20.49	\$6.10	\$5.40	\$0.94	\$32.93
3	55	\$22.54	\$6.71	\$9.71	\$1.15	\$40.11
4	60	\$24.59	\$7.32	\$9.71	\$1.23	\$42.85
5	65	\$26.64	\$7.93	\$9.71	\$1.31	\$45.59
6	70	\$28.69	\$8.54	\$9.71	\$1.39	\$48.33
7	75	\$30.74	\$9.15	\$9.71	\$1.47	\$51.07
8	80	\$32.78	\$9.76	\$17.66	\$1.78	\$61.98
9	85	\$34.83	\$10.37	\$17.66	\$1.86	\$64.72
10	90	\$36.88	\$10.98	\$17.66	\$1.94	\$67.46

**Effective Date - 01/01/2025**

Step	percent	Apprentice Base Wage	Health	Pension	Supplemental Unemployment	Total Rate
1	45	\$19.00	\$5.49	\$4.86	\$0.85	\$30.20
2	50	\$21.12	\$6.10	\$5.40	\$0.94	\$33.56
3	55	\$23.23	\$6.71	\$9.71	\$1.15	\$40.80
4	60	\$25.34	\$7.32	\$9.71	\$1.23	\$43.60
5	65	\$27.45	\$7.93	\$9.71	\$1.31	\$46.40
6	70	\$29.56	\$8.54	\$9.71	\$1.39	\$49.20
7	75	\$31.67	\$9.15	\$9.71	\$1.47	\$52.00
8	80	\$33.78	\$9.76	\$17.66	\$1.78	\$62.98
9	85	\$35.90	\$10.37	\$17.66	\$1.86	\$65.79
10	90	\$38.01	\$10.98	\$17.66	\$1.94	\$68.59

**Notes:**

**Apprentice to Journeyworker Ratio:1:3**

SPECIALIZED EARTH MOVING EQUIP < 35 TONS TEAMSTERS JOINT COUNCIL NO. 10 ZONE B	12/01/2024	\$40.24	\$15.07	\$20.17	\$0.00	\$75.48
	01/01/2025	\$40.24	\$15.57	\$20.17	\$0.00	\$75.98
	06/01/2025	\$41.24	\$15.57	\$20.17	\$0.00	\$76.98
	12/01/2025	\$41.24	\$15.57	\$21.78	\$0.00	\$78.59
	01/01/2026	\$41.24	\$16.17	\$21.78	\$0.00	\$79.19
	06/01/2026	\$42.24	\$16.17	\$21.78	\$0.00	\$80.19
	12/01/2026	\$42.24	\$16.17	\$23.52	\$0.00	\$81.93
	01/01/2027	\$42.24	\$16.77	\$23.52	\$0.00	\$82.53



Classification	Effective Date	Base Wage	Health	Pension	Supplemental Unemployment	Total Rate
SPECIALIZED EARTH MOVING EQUIP > 35 TONS <i>TEAMSTERS JOINT COUNCIL NO. 10 ZONE B</i>	12/01/2024	\$40.53	\$15.07	\$20.17	\$0.00	\$75.77
	01/01/2025	\$40.53	\$15.57	\$20.17	\$0.00	\$76.27
	06/01/2025	\$41.53	\$15.57	\$20.17	\$0.00	\$77.27
	12/01/2025	\$41.53	\$15.57	\$21.78	\$0.00	\$78.88
	01/01/2026	\$41.53	\$16.17	\$21.78	\$0.00	\$79.48
	06/01/2026	\$42.53	\$16.17	\$21.78	\$0.00	\$80.48
	12/01/2026	\$42.53	\$16.17	\$23.52	\$0.00	\$82.22
	01/01/2027	\$42.53	\$16.77	\$23.52	\$0.00	\$82.82
SPRINKLER FITTER <i>SPRINKLER FITTERS LOCAL 669</i>	04/01/2023	\$47.43	\$11.45	\$16.61	\$0.00	\$75.49

**Apprentice - SPRINKLER FITTER - Local 669**

**Effective Date - 04/01/2023**

Step	percent	Apprentice Base Wage	Health	Pension	Supplemental Unemployment	Total Rate
1	45	\$21.34	\$8.22	\$0.00	\$0.00	\$29.56
2	50	\$23.72	\$8.22	\$0.00	\$0.00	\$31.94
3	55	\$26.09	\$11.45	\$7.20	\$0.00	\$44.74
4	60	\$28.46	\$11.45	\$8.35	\$0.00	\$48.26
5	65	\$30.83	\$11.45	\$8.35	\$0.00	\$50.63
6	70	\$33.20	\$11.45	\$8.60	\$0.00	\$53.25
7	75	\$35.57	\$11.45	\$8.60	\$0.00	\$55.62
8	80	\$37.94	\$11.45	\$8.60	\$0.00	\$57.99
9	85	\$40.32	\$11.45	\$8.60	\$0.00	\$60.37
10	90	\$42.69	\$11.45	\$8.60	\$0.00	\$62.74

**Notes:**

**Apprentice to Journeyworker Ratio:1:1**

TELECOMMUNICATION TECHNICIAN <i>ELECTRICIANS LOCAL 7</i>	06/30/2024	\$50.01	\$13.00	\$14.86	\$0.00	\$77.87
	12/29/2024	\$51.06	\$13.25	\$15.06	\$0.00	\$79.37
	06/29/2025	\$52.16	\$13.50	\$15.21	\$0.00	\$80.87
	12/28/2025	\$53.26	\$13.75	\$15.36	\$0.00	\$82.37
	06/28/2026	\$54.41	\$14.00	\$15.46	\$0.00	\$83.87
	01/03/2027	\$55.56	\$14.25	\$15.56	\$0.00	\$85.37

**Classification**

**Effective Date    Base Wage    Health    Pension    Supplemental Unemployment    Total Rate**

**Apprentice - TELECOMMUNICATION TECHNICIAN - Local 7**

**Effective Date - 06/30/2024**

Step	percent	Apprentice Base Wage	Health	Pension	Supplemental Unemployment	Total Rate
1	40	\$20.00	\$7.20	\$0.60	\$0.00	\$27.80
2	45	\$22.50	\$7.20	\$0.68	\$0.00	\$30.38
3	50	\$25.01	\$13.00	\$7.40	\$0.00	\$45.41
4	55	\$27.51	\$13.00	\$7.48	\$0.00	\$47.99
5	65	\$32.51	\$13.00	\$9.64	\$0.00	\$55.15
6	70	\$35.01	\$13.00	\$11.06	\$0.00	\$59.07

**Effective Date - 12/29/2024**

Step	percent	Apprentice Base Wage	Health	Pension	Supplemental Unemployment	Total Rate
1	40	\$20.42	\$7.35	\$0.61	\$0.00	\$28.38
2	45	\$22.98	\$7.35	\$0.69	\$0.00	\$31.02
3	50	\$25.53	\$13.25	\$7.47	\$0.00	\$46.25
4	55	\$28.08	\$13.25	\$7.54	\$0.00	\$48.87
5	65	\$33.19	\$13.25	\$9.74	\$0.00	\$56.18
6	70	\$35.74	\$13.25	\$11.19	\$0.00	\$60.18

**Notes:**

Steps are 800 hours

**Apprentice to Journeyworker Ratio:1:1**

TERRAZZO FINISHERS	08/01/2024	\$63.44	\$11.49	\$23.59	\$0.00	\$98.52
BRICKLAYERS LOCAL 3 (SPR/PITT) - MARBLE & TILE	02/01/2025	\$64.74	\$11.49	\$23.59	\$0.00	\$99.82
	08/01/2025	\$66.89	\$11.49	\$23.59	\$0.00	\$101.97
	02/10/2026	\$68.24	\$11.49	\$23.59	\$0.00	\$103.32
	08/01/2026	\$70.44	\$11.49	\$23.59	\$0.00	\$105.52
	02/01/2027	\$71.84	\$11.49	\$23.59	\$0.00	\$106.92

**Classification**

**Effective Date    Base Wage    Health    Pension    Supplemental Unemployment    Total Rate**

**Apprentice - TERRAZZO FINISHER-Local 3 Marble/Tile (Spr/Ptt)**

**Effective Date - 08/01/2024**

Step	percent	Apprentice Base Wage	Health	Pension	Supplemental Unemployment	Total Rate
1	50	\$31.72	\$11.49	\$23.59	\$0.00	\$66.80
2	60	\$38.06	\$11.49	\$23.59	\$0.00	\$73.14
3	70	\$44.41	\$11.49	\$23.59	\$0.00	\$79.49
4	80	\$50.75	\$11.49	\$23.59	\$0.00	\$85.83
5	90	\$57.10	\$11.49	\$23.59	\$0.00	\$92.18

**Effective Date - 02/01/2025**

Step	percent	Apprentice Base Wage	Health	Pension	Supplemental Unemployment	Total Rate
1	50	\$32.37	\$11.49	\$23.59	\$0.00	\$67.45
2	60	\$38.84	\$11.49	\$23.59	\$0.00	\$73.92
3	70	\$45.32	\$11.49	\$23.59	\$0.00	\$80.40
4	80	\$51.79	\$11.49	\$23.59	\$0.00	\$86.87
5	90	\$58.27	\$11.49	\$23.59	\$0.00	\$93.35

**Notes:**

---

**Apprentice to Journeyworker Ratio:1:5**

TERRAZZO MECHANIC	08/01/2024	\$64.52	\$11.49	\$23.56	\$0.00	\$99.57
BRICKLAYERS LOCAL 3 (SPR/PITT) - MARBLE & TILE	02/01/2025	\$65.82	\$11.49	\$23.56	\$0.00	\$100.87
	08/01/2025	\$67.97	\$11.49	\$23.56	\$0.00	\$103.02
	02/01/2026	\$69.32	\$11.49	\$23.56	\$0.00	\$104.37
	08/01/2026	\$71.52	\$11.49	\$23.56	\$0.00	\$106.57
	02/01/2027	\$72.92	\$11.49	\$23.56	\$0.00	\$107.97

<b>Classification</b>	<b>Effective Date</b>	<b>Base Wage</b>	<b>Health</b>	<b>Pension</b>	<b>Supplemental Unemployment</b>	<b>Total Rate</b>
-----------------------	-----------------------	------------------	---------------	----------------	----------------------------------	-------------------

**Apprentice - TERRAZZO MECH - Local 3 Marble/Tile (Spr/Pitt)**

**Effective Date - 08/01/2024**

Step	percent	Apprentice Base Wage	Health	Pension	Supplemental Unemployment	Total Rate
1	50	\$32.26	\$11.49	\$23.56	\$0.00	\$67.31
2	60	\$38.71	\$11.49	\$23.56	\$0.00	\$73.76
3	70	\$45.16	\$11.49	\$23.56	\$0.00	\$80.21
4	80	\$51.62	\$11.49	\$23.56	\$0.00	\$86.67
5	90	\$58.07	\$11.49	\$23.56	\$0.00	\$93.12

**Effective Date - 02/01/2025**

Step	percent	Apprentice Base Wage	Health	Pension	Supplemental Unemployment	Total Rate
1	50	\$32.91	\$11.49	\$23.56	\$0.00	\$67.96
2	60	\$39.49	\$11.49	\$23.56	\$0.00	\$74.54
3	70	\$46.07	\$11.49	\$23.56	\$0.00	\$81.12
4	80	\$52.66	\$11.49	\$23.56	\$0.00	\$87.71
5	90	\$59.24	\$11.49	\$23.56	\$0.00	\$94.29

**Notes:**

**Apprentice to Journeyworker Ratio:1:5**

<b>TEST BORING DRILLER</b> <i>LABORERS - FOUNDATION AND MARINE</i>	12/01/2024	\$51.28	\$9.65	\$18.22	\$0.00	\$79.15
	06/01/2025	\$52.78	\$9.65	\$18.22	\$0.00	\$80.65
	12/01/2025	\$54.28	\$9.65	\$18.22	\$0.00	\$82.15
	06/01/2026	\$55.83	\$9.65	\$18.22	\$0.00	\$83.70
	12/01/2026	\$57.33	\$9.65	\$18.22	\$0.00	\$85.20

For apprentice rates see "Apprentice- LABORER"

<b>TEST BORING DRILLER HELPER</b> <i>LABORERS - FOUNDATION AND MARINE</i>	12/01/2024	\$47.07	\$9.65	\$18.22	\$0.00	\$74.94
	06/01/2025	\$48.57	\$9.65	\$18.22	\$0.00	\$76.44
	12/01/2025	\$50.07	\$9.65	\$18.22	\$0.00	\$77.94
	06/01/2026	\$51.62	\$9.65	\$18.22	\$0.00	\$79.49
	12/01/2026	\$53.12	\$9.65	\$18.22	\$0.00	\$80.99

For apprentice rates see "Apprentice- LABORER"

<b>TEST BORING LABORER</b> <i>LABORERS - FOUNDATION AND MARINE</i>	12/01/2024	\$46.95	\$9.65	\$18.22	\$0.00	\$74.82
	06/01/2025	\$48.45	\$9.65	\$18.22	\$0.00	\$76.32
	12/01/2025	\$49.95	\$9.65	\$18.22	\$0.00	\$77.82
	06/01/2026	\$51.50	\$9.65	\$18.22	\$0.00	\$79.37
	12/01/2026	\$53.00	\$9.65	\$18.22	\$0.00	\$80.87

For apprentice rates see "Apprentice- LABORER"

<b>TRACTORS</b> <i>OPERATING ENGINEERS LOCAL 98</i>	12/01/2023	\$38.42	\$13.78	\$15.15	\$0.00	\$67.35
--	------------	---------	---------	---------	--------	---------

For apprentice rates see "Apprentice- OPERATING ENGINEERS"

Classification	Effective Date	Base Wage	Health	Pension	Supplemental Unemployment	Total Rate
TRAILERS FOR EARTH MOVING EQUIPMENT <i>TEAMSTERS JOINT COUNCIL NO. 10 ZONE B</i>	12/01/2024	\$40.82	\$15.07	\$20.17	\$0.00	\$76.06
	01/01/2025	\$40.82	\$15.57	\$20.17	\$0.00	\$76.56
	06/01/2025	\$41.82	\$15.57	\$20.17	\$0.00	\$77.56
	12/01/2025	\$41.82	\$15.57	\$21.78	\$0.00	\$79.17
	01/01/2026	\$41.82	\$16.17	\$21.78	\$0.00	\$79.77
	06/01/2026	\$42.82	\$16.17	\$21.78	\$0.00	\$80.77
	12/01/2026	\$42.82	\$16.17	\$23.52	\$0.00	\$82.51
	01/01/2027	\$42.82	\$16.77	\$23.52	\$0.00	\$83.11
TUNNEL WORK - COMPRESSED AIR <i>LABORERS (COMPRESSED AIR)</i>	12/01/2024	\$59.18	\$9.65	\$19.00	\$0.00	\$87.83
	06/01/2025	\$60.68	\$9.65	\$19.00	\$0.00	\$89.33
	12/01/2025	\$62.18	\$9.65	\$19.00	\$0.00	\$90.83
	06/01/2026	\$63.73	\$9.65	\$19.00	\$0.00	\$92.38
	12/01/2026	\$65.23	\$9.65	\$19.00	\$0.00	\$93.88
For apprentice rates see "Apprentice- LABORER"						
TUNNEL WORK - COMPRESSED AIR (HAZ. WASTE) <i>LABORERS (COMPRESSED AIR)</i>	12/01/2024	\$61.18	\$9.65	\$19.00	\$0.00	\$89.83
	06/01/2025	\$62.68	\$9.65	\$19.00	\$0.00	\$91.33
	12/01/2025	\$64.18	\$9.65	\$19.00	\$0.00	\$92.83
	06/01/2026	\$65.73	\$9.65	\$19.00	\$0.00	\$94.38
	12/01/2026	\$67.23	\$9.65	\$19.00	\$0.00	\$95.88
For apprentice rates see "Apprentice- LABORER"						
TUNNEL WORK - FREE AIR <i>LABORERS (FREE AIR TUNNEL)</i>	12/01/2024	\$51.25	\$9.65	\$19.00	\$0.00	\$79.90
	06/01/2025	\$52.75	\$9.65	\$19.00	\$0.00	\$81.40
	12/01/2025	\$54.25	\$9.65	\$19.00	\$0.00	\$82.90
	06/01/2026	\$55.80	\$9.65	\$19.00	\$0.00	\$84.45
	12/01/2026	\$57.30	\$9.65	\$19.00	\$0.00	\$85.95
For apprentice rates see "Apprentice- LABORER"						
TUNNEL WORK - FREE AIR (HAZ. WASTE) <i>LABORERS (FREE AIR TUNNEL)</i>	12/01/2024	\$53.25	\$9.65	\$19.00	\$0.00	\$81.90
	06/01/2025	\$54.75	\$9.65	\$19.00	\$0.00	\$83.40
	12/01/2025	\$56.25	\$9.65	\$19.00	\$0.00	\$84.90
	06/01/2026	\$57.80	\$9.65	\$19.00	\$0.00	\$86.45
	12/01/2026	\$59.30	\$9.65	\$19.00	\$0.00	\$87.95
For apprentice rates see "Apprentice- LABORER"						
VAC-HAUL <i>TEAMSTERS JOINT COUNCIL NO. 10 ZONE B</i>	12/01/2024	\$40.24	\$15.07	\$20.17	\$0.00	\$75.48
	01/01/2025	\$40.24	\$15.57	\$20.17	\$0.00	\$75.98
	06/01/2025	\$41.24	\$15.57	\$20.17	\$0.00	\$76.98
	12/01/2025	\$41.24	\$15.57	\$21.78	\$0.00	\$78.59
	01/01/2026	\$41.24	\$16.17	\$21.78	\$0.00	\$79.19
	06/01/2026	\$42.24	\$16.17	\$21.78	\$0.00	\$80.19
	12/01/2026	\$42.24	\$16.17	\$23.52	\$0.00	\$81.93
	01/01/2027	\$42.24	\$16.77	\$23.52	\$0.00	\$82.53

Classification	Effective Date	Base Wage	Health	Pension	Supplemental Unemployment	Total Rate
WAGON DRILL OPERATOR <i>LABORERS - ZONE 3 (BUILDING &amp; SITE)</i>	12/02/2024	\$36.00	\$9.65	\$17.07	\$0.00	\$62.72
	06/02/2025	\$37.25	\$9.65	\$17.07	\$0.00	\$63.97
	12/01/2025	\$38.50	\$9.65	\$17.07	\$0.00	\$65.22
	06/01/2026	\$39.80	\$9.65	\$17.07	\$0.00	\$66.52
	12/07/2026	\$41.10	\$9.65	\$17.07	\$0.00	\$67.82
	06/07/2027	\$42.50	\$9.65	\$17.07	\$0.00	\$69.22
	12/06/2027	\$43.90	\$9.65	\$17.07	\$0.00	\$70.62
	06/05/2028	\$45.40	\$9.65	\$17.07	\$0.00	\$72.12
	12/04/2028	\$46.90	\$9.65	\$17.07	\$0.00	\$73.62
For apprentice rates see "Apprentice- LABORER"						
WAGON DRILL OPERATOR (HEAVY & HIGHWAY) <i>LABORERS - ZONE 3 (HEAVY &amp; HIGHWAY)</i>	12/01/2024	\$36.00	\$9.65	\$15.06	\$0.00	\$60.71
	06/01/2025	\$37.25	\$9.65	\$15.06	\$0.00	\$61.96
	12/01/2025	\$38.49	\$9.65	\$15.06	\$0.00	\$63.20
	06/01/2026	\$39.79	\$9.65	\$15.06	\$0.00	\$64.50
	12/01/2026	\$41.08	\$9.65	\$15.06	\$0.00	\$65.79
For apprentice rates see "Apprentice- LABORER (Heavy and Highway)"						
WATER METER INSTALLER <i>PLUMBERS &amp; PIPEFITTERS LOCAL 104</i>	03/17/2024	\$49.21	\$9.55	\$17.10	\$0.00	\$75.86
For apprentice rates see "Apprentice- PLUMBER/PIPEFITTER" or "PLUMBER/GASFITTER"						
<b>Marine Drilling</b>						
BLASTER <i>MARINE DRILLING</i>	01/01/2018	\$41.82	\$7.63	\$3.60	\$0.00	\$53.05
BOAT CAPTAIN <i>MARINE DRILLING</i>	01/01/2018	\$33.87	\$7.63	\$3.30	\$0.00	\$44.80
BOAT CAPTAIN / Over 1,000 hp <i>MARINE DRILLING</i>	01/01/2018	\$38.06	\$7.63	\$3.60	\$0.00	\$49.29
CORE DRILLER <i>MARINE DRILLING</i>	01/01/2018	\$31.43	\$7.63	\$2.90	\$0.00	\$41.96
CORE DRILLER HELPER <i>MARINE DRILLING</i>	01/01/2018	\$28.47	\$7.63	\$3.00	\$0.00	\$39.10
DRILLER <i>MARINE DRILLING</i>	01/01/2018	\$39.70	\$7.63	\$3.60	\$0.00	\$50.93
ENGINEER <i>MARINE DRILLING</i>	01/01/2018	\$39.69	\$7.63	\$3.50	\$0.00	\$50.82
HELPER <i>MARINE DRILLING</i>	01/01/2018	\$34.24	\$7.63	\$3.00	\$0.00	\$44.87
MACHINIST <i>MARINE DRILLING</i>	01/01/2018	\$38.88	\$7.63	\$3.30	\$0.00	\$49.81
OILER - MARINE DRILLING <i>MARINE DRILLING</i>	01/01/2018	\$34.24	\$7.63	\$3.00	\$0.00	\$44.87
TUG DECKHAND <i>MARINE DRILLING</i>	01/01/2018	\$27.61	\$7.63	\$3.00	\$0.00	\$38.24
WELDER <i>MARINE DRILLING</i>	01/01/2018	\$38.88	\$7.63	\$3.30	\$0.00	\$49.81
<b>Op Eng Marine (Dredging Work)</b>						
BOAT OPERATOR <i>OPERATING ENGINEERS - MARINE DIVISION</i>	10/01/2017	\$29.26	\$7.63	\$3.30	\$0.00	\$40.19
CERTIFIED WELDER <i>OPERATING ENGINEERS - MARINE DIVISION</i>	10/01/2017	\$31.09	\$7.63	\$3.60	\$0.00	\$42.32

<b>Classification</b>	<b>Effective Date</b>	<b>Base Wage</b>	<b>Health</b>	<b>Pension</b>	<b>Supplemental Unemployment</b>	<b>Total Rate</b>
CHIEF WELDER/ CHIEF MATE <i>OPERATING ENGINEERS - MARINE DIVISION</i>	10/01/2017	\$33.02	\$7.63	\$3.60	\$0.00	\$44.25
DERRICK / SPIDER / SPILLBARGE OPERATOR <i>OPERATING ENGINEERS - MARINE DIVISION</i>	10/01/2017	\$33.02	\$7.63	\$3.60	\$0.00	\$44.25
DRAG BARGE OPERATOR / WELDER / MATE <i>OPERATING ENGINEERS - MARINE DIVISION</i>	10/01/2017	\$30.24	\$7.63	\$3.30	\$0.00	\$41.17
ENGINEER / ELECTRICIAN <i>OPERATING ENGINEERS - MARINE DIVISION</i>	10/01/2017	\$33.02	\$7.63	\$3.60	\$0.00	\$44.25
LICENSED BOAT OPERATOR <i>OPERATING ENGINEERS - MARINE DIVISION</i>	10/01/2017	\$33.02	\$7.63	\$3.60	\$0.00	\$44.25
LICENSED TUG OPERATOR OVER 1000HP <i>OPERATING ENGINEERS - MARINE DIVISION</i>	10/01/2017	\$38.18	\$7.63	\$3.60	\$0.00	\$49.41
MAINTENANCE ENGINEER <i>OPERATING ENGINEERS - MARINE DIVISION</i>	10/01/2017	\$33.03	\$7.63	\$3.60	\$0.00	\$44.26
OILER - MARINE DIVISION <i>OPERATING ENGINEERS - MARINE DIVISION</i>	10/01/2017	\$24.30	\$7.63	\$3.00	\$0.00	\$34.93
OPERATOR / LEVERMAN <i>OPERATING ENGINEERS - MARINE DIVISION</i>	10/01/2017	\$38.18	\$7.63	\$3.60	\$0.00	\$49.41
RODMAN / SCOWMAN <i>OPERATING ENGINEERS - MARINE DIVISION</i>	10/01/2017	\$24.30	\$7.63	\$3.00	\$0.00	\$34.93
SHOREMAN / DECKHAND <i>OPERATING ENGINEERS - MARINE DIVISION</i>	10/01/2017	\$24.30	\$7.63	\$3.00	\$0.00	\$34.93

**Additional Apprentices Information:**

All apprentices must be registered with the Division of Apprenticeship Training (DAS) in accordance with M.G.L. c. 23, §§ 11E-11L. Minimum wage rates for apprentices employed on public works projects are listed above as a percentage of the hourly prevailing wage rate established by the Commissioner under the provisions of M.G.L. c. 149, §§ 26-27D. Apprentice ratios are established by DAS pursuant to M.G.L. c. 23, §§ 11E-11L. Ratios are expressed as the allowable number of apprentices to journeymen or fraction thereof, unless otherwise specified. The ratios listed herein have been taken from relevant private collective bargaining agreements (CBAs) and are provided for illustrative purposes only. They have not been independently verified as being accurate or continuing to be accurate. Parties having questions regarding what ratio to use should contact DAS.

THIS PAGE INTENTIONALLY LEFT BLANK



DOCUMENT A00801

**SPECIAL PROVISIONS****DISTRICT 2****Scheduled and Emergency Structural Repairs at Various Locations**

Labor participation goals for this Project shall be 15.3% for minorities and 6.9% for women for each job category. The goals are applicable to both Contractor's and Subcontractor's on-site construction workforce. Refer to Document 00820 for details.

**SCOPE OF WORK**

All work under this Contract shall be done in conformance with the *2024 Standard Specifications for Highways and Bridges*, the *Supplemental Specifications* contained in this book, the *2017 Construction Standard Details*, the *Traffic Management Plans and Detail Drawings*, *MassDOT Work Zone Safety Temporary Traffic Control*, the *1990 Standard Drawings for Signs and Supports*; the *2015 Overhead Signal Structure and Foundation Standard Drawings*, the *2009 Manual on Uniform Traffic Control Devices (MUTCD) with Revisions 1, 2, and 3* and the *November 2022 Massachusetts Amendments to the MUTCD*; the *1968 Standard Drawings for Traffic Signals and Highway Lighting*; *The American Standard for Nursery Stock*; the Plans and these Special Provisions.

The work to be done under this Contract consists of scheduled and emergency structural repairs and related work performed on bridges under the control of District 2 at various locations. The Contractor will be notified of the scheduled repairs by work order per each location. The Work will include, but not be limited to, extending deck drainpipes, replacing bleeders, repairing deteriorated steel beam ends, structural steel bracing, utility supports, bearings and cleaning (full removal) and painting of existing structural steel.

The work to be performed shall consist of furnishing all material, equipment, labor, and traffic control required to perform the necessary repair work, according to the respective Contract bid Items. All materials and equipment shall be approved by the Engineer prior to work commencing.

All work is to be performed within the existing State, City or Town roadway layouts. No rights to enter on, or occupy, private property have been acquired for this project.

The work to be done under this Contract also includes engineering services for the design of structural repairs, furnishing various artisans, materials, and special equipment as specified in Item 100.1 "Base Labor Rate". Where work items ordered by the Engineer are not in the list of bid items, the work will be paid for as Time and Material (Non-Bid Items).

---

## **SUBSECTION 7.05 INSURANCE REQUIREMENTS**

### **B. Public Liability Insurance**

The insurance requirements set forth in this subsection are in addition to the requirements of the Standard Specifications and supersede all other requirements.

#### **Paragraphs 1 and 2**

The Massachusetts Department of Transportation and applicable railroads shall be named as additional insureds.

## **RAILROAD INSURANCE REQUIREMENTS**

*(Supplementing Subsection 7.05)*

Railroad insurance will be in accordance with Subsection 7.05 of the Standard Specifications and the following:

The insurance requirements set forth in this section are in addition to the requirements of the Standard Specifications and supersede all other requirements.

Since the locations of bridges involving railroads are unknown, the Contractor will not be required to submit railroad insurance prior to execution of the Contract.

Upon assignment of a work order which requires railroad insurance, the Contractor shall submit to the Engineer all statements/estimates from a licensed insurer, which will meet the insurance requirements of the affected railroad. The Contractor should be aware that each railroad has its own specified minimum insurance requirements.

After determination of the necessity and amount of the proposed insurance required by the affected railroad, the Contractor will be given a written notice to proceed with the acquisition of the insurance.

After acquisition of insurance, the Contractor shall submit the railroad insurance information to the MassDOT in accordance with Subsection 7.05 of the Standard Specifications. The Contractor shall submit the railroad insurance amount as well as railroad license and review fees to the Department for reimbursement. The Contractor will be reimbursed for the insurance premium upon submittal of paid receipts.

If the Contractor is unable to secure said railroad insurance or is uninsurable, the Engineer may decide to cancel all future obligations and terminate the contract.

Following is the list (but not limited) of the railroad companies that operate railroad in the District at various locations:

**RAILROAD CONTACT INFORMATION FOR DISTRICT TWO**

CSX  
1 Bell Crossing Road  
Selkirk, NY 12158  
Attn: John Heigel  
(518) 767 – 6373

CSX –Flagger  
4 Neshaminy Interplex  
Suite 205  
Trevose, PA 19053  
Derek S. Mihaly  
Office: 215-218-3391  
[derek\\_mihaly@csx.com](mailto:derek_mihaly@csx.com)  
NECRR Flagging  
Deb.Bocash@GWRR.com  
(802) - 527 - 3444  
Timothy.Lesniak@GWRR.com  
Roadmaster  
(860) – 817 – 5847

New England Central Railroad  
2 Federal Street – Suite 201  
St. Albans, VT 05478  
Attn: Donna Killingworth  
(585) 785 – 6400

Genesee & Wyoming Railroad Flagging

Genesee & Wyoming Railroad  
Charles Hunter  
AVP Government Affairs  
G&W RR Services, Inc.  
802-309-8831

Mass. Central Railroad  
P.O. Box 250  
South Barre, MA 01074  
Attn: Robert Bentley  
(978) 355-5900

Mass Central Railroad Flagging

Pioneer Valley Railroad  
P.O. Box 995 – 1 Depot Street  
Westfield, MA 01085

Pioneer Valley Railroad Flagging  
Attn: Justin Tilton  
(413) – 568 - 3331 (office)  
(413) – 458 - 8266 (cell)

AMTRAK, Contractor Safety \*\*  
30th & Market Street  
Philadelphia, PA 1904  
Attn: Dawn Bey  
(215) 349-1553

AMTRAK Flagging

\*\*Note: Prior to the start of the Contract, the Contractor is required to obtain AMTRAK safety and security certificates for respective personnel that will work on bridges involving AMTRAK rail lines. The cost of the training shall be borne by the Contractor. A copy of the certificates shall be provided to the Engineer. The Contractor shall abide by all AMTRAK and Federal Regulations and requirements when working on AMTRAK property. It should be noted that all workers are required to wear Orange reflectorized vests when working on or near AMTRAK property. No other color safety vest shall be used.

## **CONTRACTOR QUESTIONS AND ADDENDUM ACKNOWLEDGEMENTS**

Prospective bidders are required to submit all questions to the Construction Contracts Engineer by 3:00 P.M. on the Tuesday of the previous week before the scheduled bid opening date. Any questions received after this time will not be considered for review by the Department.

Contractors should email questions and addendum acknowledgements to the following email address [massdotSpecifications@dot.state.ma.us](mailto:massdotSpecifications@dot.state.ma.us). The MassDOT project file number and municipality is to be placed in the subject line.

## **LOCATION OF WORK**

Work under this contract may include any bridges, viaducts, tunnels, and approach ramps within District 2 as assigned by the Engineer. The following web link provides the cities and towns under the jurisdiction of District 2:

<https://www.mass.gov/service-details/find-your-highway-district-office>

Select the district and click “Submit” button.

Locations are unknown during the bidding process. The District will provide written or verbal work orders for each unknown bridge location to be repaired. The District reserves the right to add and remove locations as needed.

No work shall be performed under this contract until specifically authorized and directed by the Department. Furthermore, this contract does not assign to the Contractor complete maintenance of the bridges owned by the Department. The Department reserves the right to perform such work as it deems best with its own forces, and/or to enter into special contracts for the maintenance of specific items.

## **SCHEDULE OF WORK**

All proposed work hours shall conform to Subsection 7.09 and be subject to the written approval of the Engineer.

Work on this project is scheduled for either a day work schedule based on a normal 8-hour day, 5-day week (M-F) from 7:00 AM to 3:30 PM, or with approval from the Engineer, a night work schedule based on a normal 10-hour day, 4 day week (M-Th) from 7:00 PM to 5:30 AM, with the Contractor and all Subcontractors working the same shift, unless otherwise approved by the Engineer.

For specific locations, allowable work hours will be determined by the District Highway Director or designated representative. On high volume and/or high-speed roadways, work may be restricted to non-peak hours or night work as required by the Engineer to avoid peak traffic volumes in order to maintain safety and productivity.

## **SCHEDULE OF WORK** (Continued)

### **Night Time Work**

All work locations requiring night hours, as approved by the Engineer, are restricted as follows:

Monday: 7:00 PM to 5:30 AM Tuesday  
Tuesday: 7:00 PM to 5:30 AM Wednesday  
Wednesday: 7:00 PM to 5:30 AM Thursday  
Thursday: 7:00 PM to 5:30 AM Friday

Work may not proceed beyond the normal 8-hour day for the day work schedule or beyond the normal 10-hours for night work unless prior approval is obtained from the Engineer for that day. Approval to work beyond the scheduled work will only be given when special conditions exist that warrant working beyond the scheduled work, as determined by the Engineer.

These time periods include the "set-up" and "breakdown" of the traffic pattern employed. No operations, personnel, or equipment will be allowed on the roadways except during working hours.

No entrance or exit ramp shall be closed to traffic except between the hours of 8:00 PM and 5:00 AM the following day or as directed. The Contractor shall be required to schedule the work activities such that not more than one ramp shall be closed during any given work period.

The work hour restrictions do not apply to emergency conditions, as determined by the Engineer.

No additional compensation will be made for work scheduled during night time hours.

## **CONTRACTOR ACCESS**

Contractors shall be aware that there are multi-span bridges with piers located away from the road and or near rivers and streams. No compensation will be made for access roads to get equipment or personnel to the work site. In addition, no compensation will be made for staging to access repair areas, etc.

## **HOLIDAY WORK RESTRICTIONS**

(Supplementing Subsection 7.09)

The District Highway Director (DHD) may authorize work to continue during these specified time periods if it is determined by the District that the work will not negatively impact the traveling public. DHD may allow work in those areas on a case by case basis and where work is behind barrier and will not impact traffic

Below are the holiday work restrictions:

### New Years Day (Federal Holiday)

No work on major arterial roadways from 5:00 AM on the day before until the normal start of business on the next subsequent business day. No work on local roadways on the holiday without permission by the DHD and the local police chief.

### Martin Luther King's Birthday (Federal Holiday)

No work restrictions due to traffic concerns, however work on local roadways requires permission by the DHD and local police chief.

### President's Day (Federal Holiday)

No work restrictions due to traffic concerns, however work on local roadways requires permission by the DHD and local police chief.

### Evacuation Day (Suffolk County State Holiday)

No work restrictions due to traffic concerns.

### Patriot's Day (State Holiday)

Work restrictions will be in place for Districts 3 and 6 along the entire Boston Marathon route and any other locations that the DHD in those districts determine are warranted so as to not to impact the marathon. All other districts work restrictions will be as per DHD.

### Mother's Day

No work on Western Turnpike and Metropolitan Highway System from 5:00 AM on the Friday before, until the normal start of business on the following day.

---

**HOLIDAY WORK RESTRICTIONS** (Continued)**Memorial Day (Federal Holiday)**

No work on major arterial roadways from 5:00 AM on the Friday before, until the normal start of business on the following day.

**Bunker Hill Day (Suffolk County State Holiday)**

No work restrictions due to traffic concerns.

**Juneteenth**

No work restrictions due to traffic concerns, however work on local roadways requires permission by the DHD and local police chief.

**Independence Day (Federal Holiday)**

No work on major arterial roadways from 5:00 AM on the day before until the normal start of business on the next subsequent business day. No work on local roadways on the holiday without permission by the DHD and the local police chief.

**Labor Day (Federal Holiday)**

No work on major arterial roadways from 5:00 AM on the Friday before, until the normal start of business on the following day.

**Columbus Day (Federal Holiday)**

No work on major arterials from 5:00 AM on the Friday before, until the normal start of business on the following day

**Veterans' Day (Federal Holiday)**

No work restrictions due to traffic concerns.

**Thanksgiving Day (Federal Holiday)**

No work on major arterials from 5:00 AM two days before until the normal start of business on the following Monday.

**Christmas Day (Federal Holiday)**

No work on major arterial roadways from 5:00 AM on the day before until the normal start of business on the next subsequent business day.

**SUBSECTION 8.02 SCHEDULE OF OPERATIONS**

Replace this subsection with the following:

An integrated cost and schedule controls program shall be implemented by the Contractor to track and document the progress of the Work from Notice to Proceed (NTP) through the Contractor Field Completion (CFC) Milestone. The Contractor's schedules will be used by the Engineer to monitor project progress, plan the level-of-effort required by the Department's work force and consultants and as a critical decision-making tool. Accordingly, the Contractor shall ensure that it complies fully with the requirements specified herein and that its schedules are both accurate and updated as required by the specification throughout the life of the project. Detailed requirements are provided in Division II, Section 722 Construction Scheduling.

---

## **SUBSECTION 8.14 UTILITY COORDINATION, DOCUMENTATION, AND MONITORING RESPONSIBILITIES**

### A. GENERAL

In accordance with the provisions of Section 8.00 Prosecution and Progress, utility coordination is a critical aspect to this Contract. This section defines the responsibility of the Contractor and MassDOT, with regard to the initial utility relocation plan and changes that occur as the prosecution of the Work progresses. The Engineer, with assistance from the Contractor shall coordinate with Utility companies that are impacted by the Contractor's operations. To support this effort, the Contractor shall provide routine and accurate schedule updates, provide notification of delays, and provide documentation of the steps taken to resolve any conflicts for the temporary and/or permanent relocations of the impacted utilities. The Contractor shall provide copies to the Engineer of the Contractor communication with the Utility companies, including but not limited to:

- Providing advanced notice, for all utility-related meetings initiated by the Contractor.
- Providing meeting minutes for all utility-related meetings that the Contractor attends.
- Providing all test pit records.
- Request for Early Utility work requirements of this section (see below).
- Notification letters for any proposed changes to Utility start dates and/or sequencing.
- Written notification to the Engineer of all apparent utility delays within seven (7) Calendar Days after a recognized delay to actual work in the field – either caused by a Utility or the Contractor.
- Any communication, initiated by the Contractor, associated with additional Right-of-Way needs in support of utility work.
- Submission of completed Utility Completion Forms.

### B. PROJECT UTILITY COORDINATION (PUC) FORM

The utility schedule and sequence information provided in the Project Utility Coordination Form (if applicable) is the best available information at the time of the bid and has been considered in setting the contract duration. The Contractor shall use all of this information in developing the bid price and the Baseline Schedule Submission, inclusive of the individual utility durations sequencing requirements, and any work that has been noted as potentially concurrent utility installations.

### C. INITIATION OF UTILITY WORK

The Engineer will issue all initial notice-to-proceed dates to each Utility company based on either the:

- 1) Contractor's accepted Baseline Schedule
- 2) An approved Early Utility Request in the form of an Early Utility sub-net schedule (in accordance with the requirements of this Subsection)
- 3) An approved Proposal Schedule

#### C.1 - BASELINE SCHEDULE – UTILITY BASIS

The Contractor shall provide a Baseline Schedule submission in accordance with the requirements of Subsection 8.02 and inclusive of all of the information provided in the PUC Form that has been issued in the Contract documents. This is to include the utility durations, sequencing of work, allowable concurrent work, and all applicable considerations that have been depicted on the PUC Form.



---

**SUBSECTION 8.14** (Continued)**C.2 – EARLY UTILITY REQUEST – (aka SUBNET SCHEDULE) PRIOR TO THE BASELINE**

All early utility work is defined as any anticipated/required utility relocations that need to occur prior to the Baseline Schedule acceptance. In all cases of proposed early utility relocation, the Contractor shall present all known information at the pre-construction conference in the form of a ‘sub-net’ schedule showing when each early utility activity needs to be issued a notice-to-proceed. The Contractor shall provide advance notification of this intent to request early utility work in writing at or prior to the Pre-Construction meeting. Prior to officially requesting approval for early utility work, the Contractor shall also coordinate with MassDOT and all utility companies (private, state or municipal) which may be impacted by the Contract. If this request is acceptable to the Utilities and to MassDOT, the Engineer will issue a notice-to-proceed to the affected Utilities, based on these accepted dates.

**C.3 – PROPOSAL SCHEDULE - CHANGES TO THE PUC FORM**

If the Contractor intends to submit a schedule (in accordance with MassDOT Standard Specifications, Division I, Subsection 8.02) that contains durations or sequencing that vary from those provided in the Project Utility Coordination (PUC) Form, the Contractor must submit this as an intended change, in the form of a Proposal Schedule and in accordance with MassDOT Standard Specifications, Division I, Subsection 8.02. These proposed changes are subject to the approval of the Engineer and the impacted utilities, in the form of this Proposal Schedule and a proposed revision to the PUC form. The Contractor shall not proceed with any changes of this type without written authorization from the Engineer, that references the approved Proposal Schedule and PUC form changes. The submission of the Baseline Schedule should not include any of these types of proposed utility changes and should not delay the submission of the Baseline Schedule. As a prerequisite to the Proposal Schedule submission, and in advance of the utility notification(s) period, the Contractor shall coordinate the proposed utility changes with the Engineer and the utility companies, to develop a mutually agreed upon schedule, prior to the start of construction.

**D. UTILITY DELAYS**

The Contractor shall notify the Engineer upon becoming aware that a Utility owner is not advancing the work in accordance with the approved utility schedule. Such notice shall be provided to the Engineer no later than seven (7) calendar days after the occurrence of the event that the Contractor believes to be a utility delay. After such notice, the Engineer and the Contractor shall continue to diligently seek the Utility Owner’s cooperation in performing their scope of Work.

In order to demonstrate that a critical path delay has been caused by a third-party Utility, the Contractor must demonstrate, through the requirements of the monthly Progress Schedule submissions and the supporting contract records associated with Subsection 8.02, 8.10 and 8.14, that the delays were beyond the control of the Contractor.

## **SUBSECTION 8.14** (Continued)

All documentation provided in this section is subject to the review and verification of the Engineer and, if required, the Utility Owner. In accordance with MassDOT Specifications, Division I, Subsection 8.10, a Time Extension will be granted for a delay caused by a Utility, only if the actual duration of the utility work is in excess of that shown on the Project Utility Coordination Form, and only if;

- 1) proper Notification of Delay was provided to MassDOT in accordance with the time requirements that are specified in this Section
- 2) the utility delay is a critical path impact to the Baseline Schedule (or most recently approved Progress Schedule)

### **E. LOCATION OF UTILITIES**

The locations of existing utilities are shown on the Contract drawings as an approximation only. The Contractor shall perform a pre-construction utility survey, including any required test pits, to determine the location of all known utilities no later than thirty (30) calendar days before commencing physical site work in the affected area.

### **F. POST UTILITY SURVEY – NOTIFICATION**

Following completion of a utility survey of existing locations, the Contractor will be responsible to notify the Engineer of any known conflicts associated with the actual location of utilities prior to the start of the work. The Engineer and the Contractor will coordinate with any utility whose assets are to be affected by the Work of this Contract. A partial list of utility contact information is provided in the Project Utility Coordination Form.

### **G. MEETINGS AND COOPERATION WITH UTILITY OWNERS**

The Contractor shall notify the Engineer in advance of any meeting they initiate with a Utility Owner's representative to allow MassDOT to participate in the meeting if needed.

Prior to the Pre-Construction Meeting, the Contractor should meet with all Utility Owners who will be required to perform utility relocations within the first 6 months of the project, to update the affected utilities of the Project Utility Coordination Form and all other applicable Contract requirements that impact the Utilities. The Contractor shall copy the Engineer on any correspondence between the Utility Owner and the Contractor.

### **H. FORCE ACCOUNT / UTILITY MONITORING REQUIREMENTS**

The Engineer will be responsible for recording daily Utility work force reports. The start, suspension, re-start, and completion dates of each of the Utilities, within each phase of the utility relocation work, will be monitored and agreed to by the Engineer and the Contractor as the work progresses.

### **I. ACCESS AND INSPECTION**

The Contractor shall be responsible for allowing Utility owners access to their own utilities to perform the relocations and/or inspections. The Contractor shall schedule their work accordingly so as not to delay or prevent each utility from maintaining their relocation schedule.

## **COMPLIANCE WITH THE NATIONAL DEFENSE AUTHORIZATION ACT**

(Supplementing Subsection 7.01)

On all projects, the “Prohibition on Certain Telecommunications and Video Surveillance Services or Equipment” Regulation (2 CFR 200.216) prohibits the Contractor from using or furnishing the following telecommunications equipment or services:

- Telecommunications equipment produced by Huawei Technologies Company or ZTE Corporation (or any subsidiary or affiliate of such entities).
- For the purpose of public safety, security of government facilities, physical security surveillance of critical infrastructure, and other national security purposes, video surveillance and telecommunications equipment produced by Hytera Communications Corporation, Hangzhou Hikvision Digital Technology Company, or Dahua Technology Company (or any subsidiary or affiliate of such entities).
- Telecommunications or video surveillance services provided by such entities or using such equipment.
- Telecommunications or video surveillance equipment or services produced or provided by an entity that the Secretary of Defense, in consultation with the Director of the National Intelligence or the Director of the Federal Bureau of Investigation, reasonably believes to be an entity owned or controlled by, or otherwise connected to, the government of a covered foreign country.

This prohibition applies to all products manufactured by the aforementioned companies, including any individual components or parts.

By submitting a bid on a project, the Contractor certifies that all work will be in compliance with the terms of 2 CFR 200.216. The Contractor shall submit a COC indicating compliance with the above provisions for all telecommunications equipment or services included in the Contract.

Payment for the item in which the materials are incorporated may be withheld until these COCs are received. Any cost involved in furnishing the certificate(s) shall be borne by the Contractor.

**TRAFFIC ACCOMMODATION***(Supplementing Subsection 7.17)*

Traffic Control along I-90 shall be scheduled and setup through MassDOT I-90 personnel. All other locations shall be setup through relevant traffic Items through this Contract. Along I-90 MassDOT I-90 personnel will provide Traffic Setups under this Contract unless unavailable or unable to provide the setups to meet the required construction schedule. Traffic Control will be provided based on the following:

- For scheduled work personnel shall allow two (2) days to determine crew availability. Personnel shall be notified no less than two (2) weeks before work is to commence with the date and time that traffic control will be needed.
- For emergency work personnel shall allow thirty (30) minutes to determine crew availability. Personnel shall be notified no less than two (2) hours before work is to commence with the date and time that traffic control will be needed.
- Scheduled or emergency work that will require more than one consecutive day or night will be reviewed on a case-by-case basis to determine MassDOT I-90 personnel coverage. If needed coverage may be split rotation between MassDOT personnel and Contractors provided setup.
- Resident Engineer must call MassDOT Area Supervisors (HMS) for the respective areas to request traffic setups. Contacts are as follows:

Area 2B: Westfield at Montgomery Line to Chicopee  
HMS Dennis Olisky at 413-530-4524

Area 2C: Ludlow to Brimfield at Sturbridge Line  
HMS Dave Pierce at 413-325-4680

The Resident Engineer shall fill out and submit a I-90 Traffic Control Work Order Form for each requested traffic setup. The assigned I-90 Traffic Setup Work Order number will be created and shown in the upper right corner of the I-90 Traffic Setup Work Order Form. The Form will then be checked and signed by the HMS as appropriate (“Unable to meet priority deadline” or “performing work in house”). If the HMS is unable to provide the requested setup to meet the Contractors repair schedule than the Contractor shall provide the necessary, Traffic Setup.

In an Emergency situation, the HMS shall provide immediate e-mail communication indicating whether they can or cannot assist with the traffic setup to the Resident Engineer. Each Department Head should be copied on the communication.

Traffic control devices shall comply with the relevant provisions of Subsection 850, the applicable sections of the 2009 Manual on Uniform Traffic Control Devices (MUTCD) with Revisions 1, 2, and 3, and the November 2022 Massachusetts Amendments to the MUTCD; the Manual for Assessing Safety Hardware, and the following:

---

## **TRAFFIC ACCOMODATIONS** (Continued)

The order of precedence for the document that governs the positioning, sizing, color(s), shape, design, and operation of temporary traffic control devices shall be as set forth below:

1. Details for a specific location that have been designed by the Contractor and approved by the Engineer.
2. Details included in this contract.
3. MassDOT's Work Zone Safety Temporary Traffic Control (Document A00815 on this Contract), Typical Details and Massachusetts Guidelines for MassDOT, Municipalities, Utilities, and Contractors.
4. MassDOT's Standard Details and Drawings for the Development of Temporary Traffic Control Plans (<https://www.mass.gov/files/documents/2017/10/24/tcp.pdf>).
5. 2022 Massachusetts Amendments to the MUTCD (<https://www.mass.gov/doc/massachusetts-amendments-to-the-mutcd-2022/download>)
6. 2009 Manual on Uniform Traffic Control Devices (MUTCD) with Revisions 1, 2, and 3 (<https://mutcd.fhwa.dot.gov/>).

During construction, the Contractor shall contact the Engineer for the most recent copy of the *Work Zone Safety Temporary Traffic Control, Typical Details and Massachusetts Guidelines for MassDOT, Municipalities, Utilities, and Contractors*.

Truck Mounted Attenuators (TMAs), when shown in any details, are mandatory. Truck Mounted Attenuators shall shadow Temporary Traffic Control service vehicles during setup and breakdown of all temporary traffic control setups on roadways with speeds greater than 45 mph.

Traffic police, when required, shall be located at a sufficient distance in advance of the work area, so that they can warn oncoming motorists of the work.

MassDOT reserves the right to provide certified Roadway Flaggers, who are MassDOT employees, at the discretion of the Engineer. The Contractor shall not be charged nor compensated for the use of MassDOT employee flaggers.

## **TRAFFIC OFFICERS AND RAILROAD FLAGGING SERVICE**

(Supplementing Subsection 7.11)

Under the provisions of Chapter 634 of the Acts of 1971, the railroad shall furnish, without cost, the necessary flag protection on the railroad right-of-way which may be required for the performance of the work.

For non-Chapter 634 bridges MassDOT will pay the Contractor for flagging costs in accordance with the procedure described in Subsection 7.11.

The Contractor, however, is responsible for all costs incurred in restoring tracks that have been disturbed by the Contractor's operations. Contractor shall comply with the requirements of the Railroad Special Provisions.

---

## **ENVIRONMENTAL REQUIREMENTS**

This heading identifies procedures that shall be followed for bridges over or adjacent to waterways, wetlands, or other bodies of water. Some repairs may be needed in emergency situations where work needs to be performed prior to final permitting.

Work on bridges below the Ordinary High Water line over non-tidal waterways will usually require Section 404 approval from the Army Corps of Engineers and Section 401 Water Quality Certification from the Department of Environmental Protection.

Repairs to bridges in tidal areas and/or navigable waters may require a Coast Guard Bridge Permit, and consistency review by Coastal Zone Management. Time frames for these bridges typically require 4 months for non-tidal bridge repairs and possibly longer for tidal bridge repairs. For permitting purposes, all proposed construction methods that may be required in, on or above water resources shall be identified by the Contractor. The proposed methods shall be reviewed with the District Environmental Engineer who will coordinate with the Environmental Division the appropriate review of permit applicability.

For emergency repairs, the District Environmental Engineer and/or Environmental Division shall be notified immediately for further guidance on obtaining appropriate approvals.

If any locations are located within rare species habitat as designated by the Massachusetts Natural Heritage and Endangered Species Program (NHESP), coordination will be undertaken by the MassDOT District Environmental Engineer. MassDOT Environmental Services Unit is available to provide support. The contractor must notify the District Highway Director and Resident Engineer in writing at least 60 days prior to desired commencement of the proposed activity, however coordination with the MassDOT District Environmental Engineer should occur as early as possible. The contractor shall be responsible for complying with any permit/restrictions/stipulations regarding work in rare species habitat.

Where repairs or reconstruction will not involve work in any waterways, wetlands or other bodies of water, erosion and siltation controls shall be implemented to ensure that construction activity does not result in siltation of the adjacent water resources. This work, when needed, will be paid under Non-Bid Items and Item 100.1 (Base Labor Rate) as required by the Engineer. Regardless of exemptions from regulations, Enforcement Actions and/or Cease and Desist Orders due to resource damages resulting from construction activity may be invoked at any time.

## **ENVIRONMENTAL PERMITTING**

No environmental permits have been obtained at this time. If Contractor erection, demolition, storage, or other procedures require work to occur in or otherwise impact water or wetland resource areas or their buffer zones, the Contractor is advised that no associated work can occur until all required environmental permits have been obtained allowing such work. The Contractor must notify the District Highway Director and the Engineer in writing at least 60 days prior to desired commencement of the proposed activity. All environmental submittals, including any contact with Local, State, or Federal environmental agencies, must be coordinated through the District Environmental Engineer. The Contractor shall fully cooperate with requests for information and provide same in a timely manner. The Contractor is further advised that the Department will not entertain a delay claim due to the time required to obtain the environmental permits. The Contractor is responsible for preventing no debris of any type to enter waterways or wetland resource areas.

After Notice to Proceed, the Contractor is responsible for complying with any and all environmental permits issued for the work covered under this Contract. The Contractor will not receive additional compensation for work required to achieve compliance with any issued environmental permits as payment for the work will be included in the various bid items.

## **DISPOSAL OF TREATED WOOD PRODUCTS**

The presence of potential treated wood products is unknown at this time, but in the event that an assignment calls for the disposal of portions of treated timber, the Contractor must dispose of the materials in accordance with all applicable state and federal regulations at a licensed facility. The Contractor will be required to submit manifests and/or certificates of disposal to the Engineer prior to the completion of the contract. All work in conjunction with the proper testing, loading, transportation, and all incidental costs required for legal disposal of treated wood products shall be covered and paid under Non-Bid Items and Item 100.1 Base Labor Rate when needed and as required by the Engineer.

## **EMERALD ASH BORER ADVISORY**

To the extent possible, all trees and brush shall be disposed on site, typically chipped and spread in place. When trees or brush must be removed, such as in urban, or otherwise populated areas, Contractor shall identify proposed location for disposal, and provide written notification to the Engineer for approval. Disposal shall be in city or town of project, or at minimum, within county, of construction operations.

## **CONTAMINATED SOIL**

Soil to be removed from the project area shall not be assumed to be uncontaminated and must be evaluated prior to off-site management for potential contamination with hazardous materials. No soil may be disposed of off-site without proper assessment by the contractor and approval from the Resident Engineer (RE), District Environmental Engineer (DEE), or the project designee.

## **SOIL STOCKPILING DIRECTIVE P-22-001**

Any stockpiling of soil must be performed in compliance with Policy Directive P-22-001, Off-Site Stockpiling of Soil from MassDOT Construction Projects. This directive limits the allowable locations for off-site stockpiling of soil generated during MassDOT projects and includes various requirements that must be satisfied by the contractor prior to off-site stockpiling.

## **PIGEON WASTE**

The Contractor shall remove and dispose of the pigeon waste and any other debris accumulated on the steel members and bridge seats in areas where work is being performed. Pigeon waste and debris material contaminants will require special handling and disposal in accordance with all Federal, state, and local requirements. No separate payment will be made for removal and disposal of pigeon waste. Cost shall be incidental to the contract pay items.



---

## **GENERAL REQUIREMENTS FOR DEMOLITION AND WORK INVOLVING PAINTED STEEL**

(02/06/2020)

Demolition and work involving painted steel shall conform to the requirements of Subsection 961 of the Standard Specifications.

### **Work Involving Painted Steel.**

Hazardous materials shall be removed in the immediate area of any intended welding, heating, saw cutting or burning of steel. Hazardous material removal is required to allow the demolition of structural steel, railings, drainage systems, utility supports, steel lamp posts, etc.

The contractor shall assume that the coatings on the steel contain lead (Pb), unless otherwise determined by testing. The contractor shall certify in writing to the Engineer the results of all testing, and shall also certify that any lead (Pb) coated steel removed from the project was not reused or buried, but was sent to a scrap metal recycling facility.

Implement and maintain programs and procedures, which comply with the requirements of this specification and all applicable standards and regulations. Comply with all applicable regulations even if the regulation is not specifically referenced herein. If a state or local regulation is more restrictive than the regulation of this specification, follow the more restrictive requirements.

This requirement is intended only for the demolition and preparation prior to repair and does not include provisions for recoating of steel.

### **Environmental**

All applicable portions of Subsections 961.65 “Worker Protection” and 961.66 “Environmental Protection and Monitoring” shall be followed when performing this work.

During chemical stripping a hand washing facility may be used in lieu of a decontamination/changing facility.

Hazardous material shall be collected during the disassembly and disposed of as outlined in Subsection 961.68 “Handling of Hazardous Waste and Reporting Release Programs”.

The applicable submittals shall be according to Subsection 961.69 “Submittals”.

---

**GENERAL REQUIREMENTS FOR DEMOLITION AND  
WORK INVOLVING PAINTED STEEL** (Continued)**Cleaning/Removal****Cutting Or Burning Of Steel**

All surfaces to be welded, heated, saw cut or burned shall be cleaned so as to remove all contaminants and/or hazardous materials, which could be discharged to the environment as a function of the subsequent operations.

Lead paint shall be removed in its entirety in an area prescribed by a 6 inch (15 cm) minimum offset from the required work. The paint removal operation may be dry abrasive blasting, wet abrasive blasting or chemical stripping.

Proper level of containment shall be used when performing this work in accordance with Subsection 961.67 "Containment". Full containment is not required during chemical stripping operation however; the Contractor shall install proper shielding and/or tarpaulins under the chemical stripping operations in order to catch all debris generated during this procedure. A cleaned area must be inspected and approved before the demolition operations are started.

During cleaning operations the Contractor shall be required to furnish and erect temporary floodlights illuminating the steel surface at a minimum of 30-foot candles. This lighting shall be used in areas where there is insufficient lighting for proper cleaning operations and inspection. The Contractor shall supply electrical power.

The Contractor shall provide support for interim and final inspection of the bridge during cleaning operations. This support shall include the necessary traffic controls and safe access to the work.

**Mechanical Disassembly Of Steel**

All surfaces to be mechanically disassembled by shear cutting or removing bolts or rivets shall not require deleading. When shear cutting or removing bolts or rivets, the Contractor shall not use any method that will cause dust and/or particles to be emitted and/or dispersed into the environment to an extent that would expose the workers above the Action Levels of  $30\mu\text{g}/\text{m}^3$ .

For purposes of limiting the lead (Pb) dust, the Contractor will be required to dampen the lead paint work areas.

The contractor shall install a proper shielding and/or tarpaulins under all lead-paint-coated surfaces to be shear cut or bolts or rivets ordered removed in order to catch any loose lead paint chips, dust or particles.

---

## **NOTICE TO OWNERS OF UTILITIES**

District 2 Utility/Constructability Engineer  
Paul Kelly 857-368-2066  
[Paul.Kelly@dot.state.ma.us](mailto:Paul.Kelly@dot.state.ma.us)

If available, existing bridge plans indicate the location of the existing known utilities in the vicinity of the work. As the accuracy and completeness of the plans are not guaranteed in any manner, it is the Contractor's responsibility to make their own investigation to assure that no damage to existing structures, drainage lines, traffic signal conduits, etc., will occur.

Written notice shall be given by the Contractor to all public service corporations or officials owning or having charge of publicly or privately owned utilities of his/her intention to commence operations affecting such utilities at least one week in advance of the commencement of such operations and the Contractor shall at that time file a copy of such notice with the Engineer.

Along the I-91 corridor, where equipment and conduit related to Intelligent Transportation Systems (ITS) and other utilities are located, the Contractor shall survey and record the location of existing conduits, pull boxes and all equipment to be removed and replaced and/or adjusted to the lines and grades of the proposed resurfacing work. The Contractor shall take all due precaution not to damage the ITS and all existing equipment. Work of any nature that is to take place shall not begin until positive location of the various conduit runs in the vicinity of the proposed work has been confirmed.

A list of public and private utilities can be found on the MassDOT website at:  
<https://www.mass.gov/info-details/utility-contacts-by-district-and-municipality>

Select District 2 on the webpage,  
Select the City/Town, and then locate the utility.

The utility contact list is for guidance only and is not guaranteed to be complete or up to date.

## **NATIONAL GRID EMERGENCY TELEPHONE NUMBERS**

### GAS:

Emergency: 1-800-233-5325

New Service: 1- 877-696-4743

Customer Support: 1-800-732-3400

### ELECTRIC:

Outage/ Emergency: 1-800-465-1212

New Service: 1-800-375-7405

Customer Support: 1-800-322-3223

## **EVERSOURCE EMERGENCY TELEPHONE NUMBERS**

### **GAS:**

Outage/ Emergency: 800-592-2000

New Service: 866-678-2744

Customer Support: 800-592-2000

### **ELECTRIC:**

Outage/ Emergency: 800-592-2000 or 844-726-7562

New Service: 1-888-633-3797 (1-888-need pwr)

Customer Support: 1-800-340-9822

## **BERKSHIRE GAS EMERGENCY TELEPHONE NUMBERS**

### **GAS:**

Outage/Emergency: 1-800-292-5012 or 413-499-1680

New Service: 1- 800-297-7144

Customer Support: 1-800-292-5012

## **NOTIFICATION OF PUBLIC OFFICIALS**

Town officials are shown at website <https://www.mass.gov/lists/massachusetts-cities-and-towns> and select the required City/Town website.

State Police are shown at website <https://www.mass.gov/info-details/massachusetts-state-police-troop-boundaries>. Select the area of jurisdiction to find the local station.

The Contractor shall inform the following officials in each area that he is assigned to work in:

Superintendent, Department of Public Works, or Town Engineer. Superintendent, Water Department, Superintendent, Sewer Departments. Police Department, Fire Department, Electric Company, Railroads.

---

## **SUPPLEMENTAL REQUIREMENTS FOR NON-BID ITEMS**

(Supplementing Subsection 3.04)

The Contractor will be paid for additional artisans, equipment rental, materials, engineering services and specialty services required to perform the work plus (10%) percent, plus actual increased bond premium.

The Contractor shall be required to furnish certified paid receipts for additional artisans, equipment rental, materials, engineering services and specialty services that are required to perform the work prior to payment by the Department. Increased bond premium for additional artisans, equipment rental, materials, engineering services and specialty services will be paid after a certified paid receipt is submitted showing payment of the increased bond.

### **NON-BID ITEMS**

For work not covered by the various bid items in this Contract, it is the intent to pay for such related work on a time and materials basis, as required by the Engineer. The payment for such work is outlined in the following sections: Payment for Materials, Payment for Rental Equipment, Payment for Engineering Services, Payment for Specialty Services/Additional Artisans.

#### **A. PAYMENT FOR MATERIALS**

The Contractor will be paid the actual cost for materials that are required to maintain or repair a bridge but are not covered under the Contract bid Items plus ten (10) percent. Any arrangements for the purchase of materials will be considered incidental. Delivery charges will be incidental to the material charges. State and Federal taxes if billed will not be reimbursed by MassDOT. No materials shall be ordered until approved by the Engineer and competitive prices may be required if the Engineer directs.

The District may have surplus materials on hand that could be included into the work. The transportation of materials and/or parts supplied by MassDOT will be included for payment under Item 100.1.

Payments for the installation of materials and/or parts will be made under Item 100.1. All materials which are necessary to perform the work under the various contract bid items shall be incidental to those Items at no additional compensation.

#### **B. PAYMENT FOR RENTAL EQUIPMENT**

The Contractor will be paid the actual rental cost for the equipment, which may be required to perform certain repair work that has not been included in the contract bid items, plus ten (10) percent. No equipment shall be rented until approved by the Engineer. The rental equipment shall not be part of the tradesman basic toolbox as specified under Item 100.1 Base Labor Rate.

---

**NON-BID ITEMS** (Continued)

Contractor-owned equipment required under this contract, (with the exception of equipment listed under the various artisans' descriptions in Item 100.1 Base Labor Rate will be reimbursed in the format outlined under Subsection 9.03 "Payment for extra Work" Section C of the Standard Specifications. Rental Equipment will not carry any overtime premium rate after being in full operation for more than 8 hours in a day.

Unless the rented equipment cost includes the operator, the Contractor will receive compensation for the operator of the "Rental Equipment" used for "Related Work" as specified in Item 100.1 Base Labor Rate.

The Contractor must get the authorization of the Resident Engineer before any equipment is rented and competitive prices may be required if the Engineer directs.

All rental equipment and tools shall be in excellent working condition. The Contractor shall not be paid for the time that the equipment is broken down.

The actual cost for rental equipment including equipment that is required when working from water below (i.e., barge equipped with 60' or higher boom lift, boat, operator, and other safety equipment) shall be judged in accordance with the rate specified in the Rental Blue Book and it is the Contractor's responsibility to provide a copy of this Blue Book to the Department. The rental compensation shall also include the cost of a boat captain/tender crew. The rental for equipment will be paid on an hourly basis and will not carry any overtime rate after eight hours of operation.

All rental equipment and tools which are necessary to prosecute the work under the various contract bid items shall be incidental to those Items at no additional compensation.

**C. PAYMENT FOR ENGINEERING SERVICES**

Each non-routine structural repair for which there is no Contract bid Item to cover the work, the Contractor shall submit a design by a Professional Engineer of the appropriate discipline registered in Massachusetts (who shall be from the Department's approved consultant list) within one week of notification (seven (7) calendar days after receipt of formal Work Order).

This design shall address all structural defects itemized in the Work Order. It shall be submitted to the Engineer and the proper railroad authority (i.e., Amtrak, MBTA. etc.) when applicable. The Contractor must get the proposed design approved by both the Engineer and proper railroad authority (when applicable) prior to commencing any work.

The Contractor will be paid the actual cost for the Engineering Services for the structural design by a Professional Engineer of the appropriate discipline registered in Massachusetts, plus ten (10) percent when any Engineering Services are required for work done on a time and materials basis for which there is no bid Item. The Engineer shall approve all engineering costs prior to any design work being undertaken.

**NON-BID ITEMS** (Continued)

All engineering services which are necessary to prosecute the work under the various Contract bid items shall be incidental to those Items at no additional compensation.

**Engineering Services Cost Estimate**

When engineering designs or other consulting services are deemed necessary by the Engineer, the design firm will submit a cost estimate of the proposed work. This estimate will include the classification, estimated hours needed, and actual hourly rate for each individual anticipated to be used in developing the finished product. The billable rates shall include overhead and profit. Overhead shall be as approved by MassDOT Audit Section or in absence of approved audited rates a maximum 155% shall apply for overhead. The profit fee is 10%. The billable rate shall be calculated using  $1.10 * (\text{Base Hourly Rate} + \text{Base Hourly} * \text{Overhead Rate } \%)$ .

**D. PAYMENT FOR SPECIALTY SERVICES/ ADDITIONAL ARTISANS**

The Contractor will be paid for any artisans that are not categorized under Item 100.1 “Base Labor Rate” (Regardless of whether the additional artisans are hired by the Contractor as a specialty sub-contractor crew, or as an individual artisan) required to repair or maintain the bridges or any work that has not been included as incidental to any Contract Bid Item plus ten (10) percent. However, no artisans shall be hired until approved by the Engineer and competitive prices may be required if the Engineer so directs. The Contractor will not bid this item. If the Engineer has knowledge of source of additional artisans, which are competitive with the Contractor's choice, then the Contractor may be required to investigate and use an alternative choice.

**COST ESTIMATES**

Where the scope of a repair task can be adequately determined and described, the Contractor, when required by the Engineer, shall be required to submit a Cost Estimate for the repair task.

Each Cost Estimate, submitted in writing, shall include an itemized scope of work, a working schedule (including the number of working days and hours worked each day by each category of artisan), work procedures and a NOT-TO-EXCEED cost breakdown itemized by the following: the number and type of workers, the number and type of equipment, barges, materials, specialty contractors, engineering services, traffic controls and police, etc. The Cost Estimate submittal must also state if roadway closures and waterway and/or bridge closures will be required.

The Engineer will approve each Cost Estimate submittal in writing. A submittal does not guarantee the Contractor will be assigned the work. Payment will be based on actual hours worked at the contractual rates for various items as previously described up to the maximum task amount. Completion of the task is the sole responsibility of the Contractor once the not-to-exceed amount has been reached. Should unforeseen problems develop during the task completion, the Contractor will submit to the Engineer a revised scope of work with a comparison to the original scope of work along with a breakdown of the additional costs for approval by the Engineer. Approval for any increases to the agreed upon not-to-exceed cost will be dependent upon the justification of the additional work.

---

**NON-BID ITEMS** (Continued)

If the Contractor performs work which is not provided for in this Contract, or which was not authorized in writing by the Engineer, said Contractor shall receive no compensation for such work.

The management of the project and generating Cost Estimates, including such items as the planning of repair details, hiring of subcontractors, meetings with affected parties, scheduling of required artisans, purchasing of the necessary materials and the arrangement of equipment rentals, etc., will be considered incidental to the work and as such, no additional compensation will be provided.

**RATES OF PAYMENT**

Payment for Non-Bid Items and Item 100.1 Base Labor Rate will be made for time spent on the project doing actual work on the Department's bridges and shall NOT include travel time to and from the Contractor's place of business and it shall also not include time for investigative field trips to find out how much material, equipment, tools, etc., may be needed for the work.

All equipment, materials, engineering costs and artisans' compensation which are necessary to prosecute the work under the various contract bid items shall be incidental to those bid Items at no additional compensation.

Note: For work covered by bid items in this contract and those not covered, there may be situations where the Department has pertinent materials or equipment stockpiled. The Department reserves the right to utilize these materials or equipment as seen fit in the prosecution of the work.

The Contractor will be reimbursed for the total actual cost (plus a percentage markup as indicated) for materials, equipment rental, additional artisans and engineering services required for related work required by the Engineer. Artisans will be compensated as specified in Item 100.1 "Base Labor Rate". The Contractor will not bid the materials, equipment rental, additional artisan, and engineering services Items.

Payment for Non-Bid Items will be based on bills submitted, covering all charges for labor, materials, and equipment according to the respective terms of the contract. Bills covering the total charges incurred in any given month are to be submitted by the fifteenth of the following month for processing.

The Contractor is encouraged to submit bills/invoices of all charges to the Engineer by the 15th of the following month. It shall be required that the Contractor furnish certified copies of any or all payrolls for the Contract, showing the name, address, and occupational classification of each employee on said works, the hours worked by, and the wages paid to such employee.



## **CONTRACTOR DESIGN REQUIREMENTS**

All design drawings and calculation submittals that are prepared and stamped by a Professional Engineer shall be checked by a second Professional Engineer. Both Professional Engineers shall be registered in the Commonwealth of Massachusetts, and be of the appropriate engineering discipline. All drawings calculation sheets shall contain the “calculated by” or “drawn by”, and “checked by” sections with the initials of both Professional Engineers.

### **GUNITE - ASBESTOS**

Gunite is a sprayed concrete material that may contain asbestos. The following bridges in District Two are believed to contain gunite:

A-15-013	H-21-008	H-21-020	N-19-045	S-24-018
H-21-014	H-21-013	H-21-067	O-03-011	W-25-002

The list of bridges and locations to be included in this Contract are unknown, the awarded Contractor will be notified per work location by work order during construction. Upon assignment of a work order, Concrete on these above bridge structures should be investigated for potential ACM content prior to disturbance. However, unidentified gunite may be present in other bridge structures in District Two as well.

### **ASBESTOS**

Asbestos may be present on bridges in forms including but not limited to asbestos cement utility conduit, pipe insulation, pipe wrap, and/or gunite/shotcrete. The contractor shall identify potential asbestos-containing material (ACM) that may be impacted as part of the contract work. If ACM or potential ACM will be physically impacted, the contractor shall communicate this information to the Engineer, District Environmental Engineer (DEE), receive approval prior to beginning work, and conduct all work in accordance with applicable federal, state, and local regulations. The work will be paid under Non-Bid items and Item 100.1 as required by the Engineer. No Assignment of work will be allowed without the approval of the Engineer.

---

## **NORTHERN LONG-EARED BAT AND TRICOLORED BAT PROTECTION**

The northern long-eared bat (*Myotis septentrionalis*; NLEB) and tricolored bat (*Perimyotis subflavus*; TCB) are listed as federally endangered or proposed endangered, respectfully, under the Endangered Species Act (ESA). The U.S. Fish and Wildlife Service (USFWS) developed this guidance to address ESA compliance and promote conservation of NLEB and TCB. As there is no Federal nexus (Federal funding or permits) for this project, Section 7 consultation was not required or conducted. However, Section 9 of the ESA prohibits anyone from “taking” or harming an endangered species, and the below language shall be adhered to in order to maintain compliance with the ESA.

If any of the project locations require work within U.S. Army Corps of Engineers (ACOE) jurisdictional wetlands, the ACOE will be the lead federal agency for ESA consultation with the U.S. Fish & Wildlife Service (USFWS). Most consultations for the NLEB take 30 days.

The following Avoidance and Minimization Measures (AMMs) must be strictly adhered to in order to protect NLEB and TCB and to be in compliance with the ESA. Contact MassDOT Environmental Services - Wildlife & Endangered Species Unit Supervisor (David Paulson, [david.j.paulson@dot.state.ma.us](mailto:david.j.paulson@dot.state.ma.us), 857-262-3378) for questions about project limits, restrictions, or conservation measures.

**The Resident Engineer can check on the status of AMM applicability by sending a locus map of the proposed work to MassDOT Highway Division’s Environmental Services Section - Wildlife & Endangered Species Unit Supervisor for review and a determination if some of the AMMs and TOY restriction can be waived.**

### **Required AMM for all projects:**

- The Contractor shall ensure all personnel working in on the project site are aware of all environmental commitments related to NLEB and TCB, including all applicable AMMs. NLEB Bat information (<https://www.fws.gov/midwest/endangered/mammals/nleb/> and <https://www.fws.gov/species/tricolored-bat-perimyotis-subflavus>) shall be made available to all personnel.

**If temporary lighting is proposed within the project scope, the following AMM is applicable:**

### **Lighting AMM:**

- Direct temporary lighting away from suitable habitat during the active season: **April 1 to October 31.**

**If the Removal of Trees and/or Woody Vegetation >3-inch in diameter is proposed within the project scope, the following AMMs are applicable:**

### **Tree AMMs:**

- If additional cutting is proposed by the Contractor that is outside the scope of this contract, additional review is required by the MassDOT Highway Division’s Environmental Services Section, and additional review and restrictions may be required by the USFWS.
- Ensure tree removal is limited to that specified in project plans and ensure that contractors understand clearing limits and how they are marked in the field (e.g., install bright colored flagging/fencing prior to any tree clearing to ensure contractors stay within clearing limits).

**NORTHERN LONG-EARED BAT PROTECTION** (Continued)

- In order to protect northern long-eared bats and their young during their active season, **no tree cutting shall be conducted during the Time of Year (TOY) restriction of April 1 to October 31**.
- Do not remove **documented** or NLEB roosts that are still suitable for roosting, or trees within 0.25 miles of roosts, or **documented** foraging habitat any time of year (<http://www.mass.gov/eea/agencies/dfg/dfw/natural-heritage/species-information-and-conservation/rare-mammals/northern-long-eared-bat.html>).
- The Contractor shall ensure all personnel working in on the project site are aware of all environmental commitments related to NLEB and TCB, including the **TOY** restriction.

**If the Bridge Work is proposed within the project scope, the following AMMs are applicable:**

**Bridge AMMs:**

- **Bridge AMM 1** - To completely avoid direct effects to roosting bats, perform any bridge removal, replacement, and/or maintenance work during the winter hibernation period unless a hibernating colony of bats is present (contact your local USFWS Field Office for exact dates). Also, follow Bridge AMM 4.

- **Note:** Bridge AMM 1 is an avoidance measure for direct effects; the full implementation of which may

not always be practicable. **If bridge removal, replacement, and/or maintenance work must be performed outside of the winter hibernation period, then follow Bridge AMMs 2-4.**

- **Bridge AMM 2 - Colony or Assuming Presence of Bats**
  - If assuming presence of bats or if bridge assessment or P/A surveys suggest presence of a colony of bats, and work is conducted during the active season, ensure activity will not disturb bats. The following types of bridge work can generally be conducted with the presence of bats:
    - above deck work where construction equipment or materials do not extend to the underside of deck where bats may be located (e.g., materials that may drip down to underside of deck), or does not include percussives (vibration) or noise levels above general traffic (e.g., road line painting, wing-wall work).
    - below deck work that is conducted away from roosting bats and does not involve percussives or noise level above general traffic (e.g., wing-wall work, some abutment, beam end, scour, or pier repair).
- **Bridge AMM 3 - Small Number of Bats**
  - If bridge assessment or P/A surveys suggest presence of a small number of bats (<5 – not a colony), and work is conducted during the active season, the following types of bridge work can generally be conducted with the presence of bats:
    - above deck work where construction equipment or materials do not extend to the underside of deck where bats may be located (e.g., materials that may drip down to underside of deck), or does not include percussives (vibration) or noise levels above general traffic (e.g., road line painting, wing-wall work).
    - below deck work that is conducted away from roosting bats and does not involve percussives or noise level above general traffic (e.g., wing-wall work, some abutment, beam end, scour, or pier repair).

---

**NORTHERN LONG-EARED BAT PROTECTION** (Continued)

- any other bridge removal, replacement, and/or maintenance work (which may include activities with percussives) conducted in the evening while the bats are feeding, starting one hour after sunset, and ending one hour before daylight excluding the hours between 10 p.m. and midnight and keep the light localized.
- **Bridge AMM 4** - If assuming presence of bats, or if bridge assessment or P/A surveys suggest presence of bats, ensure suitable roosting habitat is maintained. Suitable roosting sites may be incorporated into the design of a new bridge.

**RESTRICTED MATERIALS**

All treated wood supplied by the Contractor shall meet the requirements of M9.05.1 for treated timber including the most recent versions of AWWA U1 & M4 which are incorporated by reference. No new wood shall be treated with inorganic arsenic [including chromated copper arsenate (CCA), ammoniacal copper arsenate (ACA), and ammoniacal copper zinc arsenate (ACZA)], creosote or pentachlorophenol in all project construction.

In the case the existing treated wood products are encountered in this project, the disposal of the treated existing wood product will be handled under the Non – Bid Items and Item 100.1 (Base Labor Rate) on this contract as required by the Engineer. All aspects of the required work are to be completed in accordance with all pertinent state and federal regulations.

All new construction materials shall be asbestos-free including any roofing felt, waterproofing materials, grout, sealer, or adhesives that may be used unless asbestos is specifically required. If any existing material is a possible ACM (asbestos containing material), all required works including Inspecting and Testing for Asbestos Containing Material, and Removal and Disposal of Asbestos will be handled and covered under Non-Bid Items and Item 100.1 (Base Labor Rate) on this contract. The Contractor must perform all asbestos handling and testing in accordance with the required regulations and as required by the Engineer and Asbestos Liability Insurance shall be obtained. The Contractor and the Massachusetts Department of Transportation shall be named as additional insureds.

---

## **CONTRACTOR NOTIFICATION**

Contractor notification and response will be classified into three categories as follows:

### 1. EMERGENCY REPAIR:

An Emergency Repair is defined as the work required to repair failed bridge elements, which is of an EMERGENCY NATURE and requires IMMEDIATE ATTENTION. The Contractor will be required to commence an Emergency Repair within four (4) hours after notification by the Department, unless otherwise directed. The nature of the Emergency work will require the Contractor to be available 24 hours per day. In addition to required construction Items, payment for any Emergency Repair Work performed will be paid under Item 748.1 Emergency Response. Emergency Repairs may be initiated verbally due to the need for immediate action but will be followed up by a Work Order assignment in the work order management system soon after.

### 2. PRIORITY REPAIR:

A Priority Repair is defined as work required to repair failed bridge elements, which is not of an Emergency nature; however, needs to be completed in a timely manner to prevent further deterioration or to meet the need of other constraints. The Contractor will be required to commence a Priority Repair within seven (7) calendar days after notification by the Department, unless otherwise directed. Priority Repairs will be initiated, and Work Orders assigned using the work order management system.

### 3. SCHEDULED REPAIR:

A Scheduled Repair is not considered to be of an Emergency nature and has no priority over other repairs. The Contractor will be required to commence scheduled work within thirty (30) calendar days after notification by the Department, unless otherwise directed. The Contractor shall immediately notify the Engineer if unable to begin physical work within thirty (30) calendar days and provide an explanation for the delay. Scheduled repairs will be initiated and Work Orders assigned using the work order management system.

The Contractor will be notified of all Work Orders through the work order management system except for Emergency repairs which may first be assigned verbally with a follow up assignment through the work order management system. The Work Order will identify the location of the work, the category of work (Emergency, Scheduled or Priority), and identify the major items required for the work. The date from which potential non-response damages will be assessed for each work order will be based on the date the work order is assigned in the work order management system to the date the Contractor begins Physical Work.

For a Priority or Scheduled Repair, the Contractor must submit a work schedule and estimate for the Engineer's review and approval within seven (7) calendar days of issuance of the work order. The Contractor's schedule and estimate shall provide information relating to equipment, materials, anticipated work hours, labor availability, itemized estimated value of the repairs, a breakdown of major components of the work (i.e. staging installation, concrete work, etc.) and estimated start and completion dates.

**CONTRACTOR NOTIFICATION** (Continued)

“Physical Work” shall be defined as “physical implementation of the required repair at the bridge site”. In no case will Physical Work include any of the following: ordering materials, fabrication of materials, organizing labor forces, coordinating with subcontractors, installing means of access and/or traffic control to implement the required repairs, installing temporary works, or other operations needed to be performed in advance of the required repairs.

This Contract contains both Emergency response mobilization payment items for Emergency Repair work, and Non-Response damages to ensure prompt action by the Contractor.

The ability to assign Emergency Repair work, if required, shall take effect as soon as this Contract is executed.

The Contractor shall have the appropriate communication capabilities that will allow the Department to notify the Contractor of an Emergency Repair on a twenty-four hour (24) per day basis.

The Contractor shall supply the District 2 Highway Director with a list of telephone numbers for personnel who can be contacted twenty-four (24) hours a day in case of an emergency.

**WORK ORDER SCHEDULE MILESTONES**

Work Orders may include complexities which will have separate milestones as indicated below. All timeframes shown below are in calendar days.

<i>Complexity</i>	<i>Milestone</i>
Engineering Design	Approved Design within 60 days of assignment
Fabricated Materials	Approved Shop Drawings within 30 Days of Work Order or approved engineering design if engineering design required. Fabrication shall begin within 14 Days of Approved Shop Drawings.
Utility Coordination	Engagement with utilities shall occur within two weeks of issuing the work order. Final approval from the utility of the proposed work or utility protection shall be within 60 days of work order issuance or 60 days of approved engineering design if engineering design required.
Railroad Coordination	Engagement with Railroads shall occur within 14 days of issuing the work order. Access agreement to railroad property shall be in place within 60 days of work order assignment. If engineering is required for a repair, the engineering design shall be provided to the railroad for approval within 30 days. Railroad flaggers shall be requested within two weeks of railroad access agreement.
Physical Work	<p>“Physical Work” shall refer to physical implementation of the required repair at the bridge site. For repairs with no additional complexities as identified in this chart time to start of Physical Work will be measured from the issuance of the work order. In no case will Physical Work include any of the following: ordering materials, fabrication of materials, organizing labor forces, coordinating with subcontractors, installing means of access and/or traffic control to implement the required repairs, installing temporary works, or other operations needed to be performed in advance of the required repairs.</p> <p>For work orders with complexities as outlined in this chart, “Physical Work” will be measured from the receipt of approval for all the necessary complexities.</p> <p>Examples:</p> <p>Work order requiring engineering design and fabrication shall measure time to beginning of Physical Work from the time of approval of the shop drawings.</p> <p>Work order requiring engineering design, fabrication, and utility coordination shall measure time to beginning of Physical Work from the approval of the shop drawings or approval of utility agreement whichever is later.</p> <p>Work order requiring engineering design, fabrication, and railroad coordination shall begin immediately upon flagger availability.</p>

All complexities and components of work orders shall be identified with milestones in the work order bar chart schedule.

---

## **NON-RESPONSE DAMAGES**

It is the intent of this provision to ensure prompt response to Work Orders based on priority. These Non-Response Damages may be waived by MassDOT when, in the opinion of the Engineer, it is in the best interest of MassDOT to do so.

If the Contractor has not met the complexity milestones as outlined in the Work Order and above, a notification will be sent to the Contractor regarding Non-Responses Damages that will be assessed. The Engineer shall assess damages in the amount of \$1,000 per day (or portion thereof) for each day beyond the milestone due date that the milestone is not met.

### **Emergency Repairs:**

If the Contractor has not started Physical Work on an assigned Emergency Repair within four (4) hours from the receipt of the notification, no payment under Item 748.1 will be made. Furthermore, the Contractor will be assessed damages in the amount of \$1,000 per hour for each hour Physical Work is delayed.

### **Priority Repairs (assuming 7 days)**

The Contractor shall commence priority work within 7 days after an assignment is issued by the Department, unless otherwise directed. If the Contractor has not started Physical Work on an assignment within 7 days, the Department will notify the Contractor in writing of the intent to issue damages. Damages will begin five (5) days after written notification to the Contractor. The Engineer will assess damages in the amount of \$1,000 per day for each day (or portion thereof) that the Work is delayed.

### **Scheduled Repairs (assuming 30 days)**

The Contractor shall commence scheduled work within 30 days after an assignment is issued by the Department, unless otherwise directed. If the Contractor has not started Physical Work on an assignment within 30 days, the Department will notify the Contractor in writing of the intent to issue damages. Damages will begin five (5) days after written notification to the Contractor. The Engineer will assess damages in the amount of \$1,000 per day for each day (or portion thereof) that the Work is delayed.

“Physical Work” shall refer to physical implementation of the required repair at the bridge site. For repairs with no additional complexities as identified in this chart time to start of Physical Work will be measured from the issuance of the work order. In no case will Physical Work include any of the following: ordering materials, fabrication of materials, organizing labor forces, coordinating with subcontractors, installing means of access and/or traffic control to implement the required repairs, installing temporary works, or other operations needed to be performed in advance of the required repairs.

If the Contractor has not submitted a work schedule or estimate for the Engineer’s review and approval on a Priority or Scheduled Repair within seven (7) calendar days after issuance of the Work Order, the Contractor will be subject to non-response damages in the amount \$500 per day.

In addition, the Engineer shall consider such delays in evaluating the Contractor’s performance.



---

**SECTION 722**  
**CONSTRUCTION SCHEDULING**  
**DESCRIPTION**

**722.20 General**

The Contractor's approach to prosecution of the Work shall be disclosed to the Department by submission of a Critical Path Method (CPM) schedule and a cost/resource loaded Construction Schedule as defined by the schedule type set forth below. These requirements are in addition to any requirements imposed in other sections.

This section establishes the requirement for scheduling submissions. There are four schedule types identified as types A, B, C and D. The schedule type applicable to this project is established in the project special provisions.

All schedules shall be prepared and submitted in accordance with this specification and the instructions contained in the Construction Schedule Toolkit located on the MassDOT-Highway Division website at <https://www.mass.gov/info-details/massdot-highway-contractors-schedule-toolkit>.

**Type A –**

- Schedule Planning Session
- Baseline CPM Schedule
- Monthly Update CPM Schedule
- Short-term Construction Schedule
- Contract Schedule Update Meeting
- Cost-loaded & Resource Loaded CPM
- Resources Graphic Reporting
- Cash Flow Projections from the CPM
- Cash Flow Charts
- Monthly Projected Spending Report (PSR)
- Contractor-furnished CPM software and computer

**Type B –**

- Schedule Planning Session
- Baseline CPM Schedule
- Monthly Update CPM Schedule
- Short-term Construction Schedule
- Contract Schedule Update Meeting
- Cost-loaded & Resource Loaded CPM
- Monthly Projected Spending Report (PSR)
- Contractor-furnished CPM software and computer

**Type C –**

- Schedule Planning Session
- Baseline CPM Schedule
- Monthly Update CPM Schedule
- Short-term Construction Schedule
- Contract Schedule Update Meeting
- Monthly Projected Spending Report (PSR)
- Contractor-furnished CPM software and computer

**SECTION 722** (Continued)**Type D -**

- Bar chart schedule updated monthly or at the request of the Engineer
- Short-term Construction Schedule
- Monthly Projected Spending Report (PSR)

**EQUIPMENT, PERSONNEL****722.40 General****A. Software Requirements**

The Contractor shall use Primavera P6 computer scheduling software.

In addition to the requirements of Section 740 – Engineer’s Field Office and Equipment, the Contractor shall provide to the Department one (1) copy of the scheduling software, one (1) software license and one (1) computer capable of running the scheduling software for the duration of the Contract. This computer and software shall be installed in the Engineer’s Field Office. The computer and software shall be maintained and serviced at no additional cost to the Department.

**B. Scheduler Requirements**

The Scheduler shall be approved by the Engineer.

For Type A, B and C Schedules the name of the Contractor’s Project Scheduler together with his/her qualifications shall be submitted to the Department for approval by the Engineer within seven (7) Calendar Days after NTP. The Project Scheduler shall have a minimum of five (5) years of project CPM scheduling experience, three (3) years of which shall be on projects of similar scope and value as the project for which the Project Scheduler is being proposed. References shall be provided from past projects that can attest to the capabilities of the Project Scheduler.

**SCHEDULING METHODS****722.60 General****A. Schedule Planning Session**

The Contractor shall conduct a schedule planning session prior to submission of the Baseline Schedule. This session will be attended by the Department and its consultants. During this session, the Contractor shall present its planned approach to the project including, but not limited to:

1. the Work to be performed by the Contractor and its subcontractors;
2. the planned construction sequence and phasing; planned crew sizes;
3. summary of equipment types, sizes, and numbers to be used for each work activity;
4. all early work related to third party utilities;
5. identification of the most critical submittals and projected submission timelines;
6. estimated durations of major work activities;
7. the anticipated Critical Path of the project and a summary of the activities on that Critical Path;
8. a summary of the most difficult schedule challenges the Contractor is anticipating and how it plans to manage and control those challenges;

**SECTION 722** (Continued)

9. a summary of the anticipated quarterly cash flow over the life of the project.

This will be an interactive session and the Contractor shall answer all questions that the Department and its consultants may have. The Contractor shall provide a written summary of the information presented and discussed during the session to the Engineer. The Contractor's Baseline Schedule and accompanying Schedule Narrative shall incorporate the information discussed at this Schedule Planning Session.

**B. Schedule Reviews by the Department****1. Baseline Schedule Reviews**

The Engineer will respond to the Baseline Schedule Submission within thirty (30) Calendar Days of receipt providing comments, questions and/or disposition that either accepts the schedule or requires revision and resubmittal. Rejected Baseline Schedules shall be resubmitted within fifteen (15) Calendar Days after receipt of the Engineer's comments.

**2. Contract Progress Schedule / Monthly Update Reviews / Recovery Schedules**

The Engineer will respond to each submittal within twenty-one (21) Calendar Days. Rejected schedules shall be resubmitted by the Contractor within five (5) Calendar Days after receipt of the Engineer's comments.

The Engineer's review comments shall not be construed as direction to change the Contractor's means and methods. The review and acceptance of the CPM schedule does not relieve the Contractor of the responsibility for accomplishing the work within the contract required completion dates. Omissions and errors in the accepted CPM schedule shall not excuse performance less than that required by the Contract.

**722.61 Schedule Content and Preparation Requirements**

All schedules shall be prepared and submitted in accordance with the instructions contained in the Construction Schedule Toolkit located on the MassDOT-Highway Division website at:

<https://www.mass.gov/info-details/massdot-highway-contractors-schedule-toolkit>

and the following:

**A. LOGIC**

The schedules shall divide the Work into activities with appropriate logic ties to show:

1. conformance with the requirements of this Section and Division I, Subsection 8.02 - Schedule of Operations
2. the Contractor's overall approach to the planning, scheduling, and execution of the Work
3. conformance with any additional sequences of Work required by the Contract Documents, including, but not limited to, Subsection 8.03 - Prosecution of Work and Subsection 8.06 – Limitations of Operations.

**SECTION 722** (Continued)**B. ACTIVITIES**

The schedule shall clearly define the progression of the Work from the Notice to Proceed (NTP) to Contractor Field Completion (CFC) by using separate activities, or including attributes within appropriate activities, to address each of the following:

1. Notice to Proceed
2. Work Breakdown Structure
3. The Critical Path is clearly defined and organized.
4. Float shall be clearly identified.
5. Detailed activities to satisfy permit requirements.
6. Subcontractor approvals at fifteen (15) Calendar Days from submittal to response
7. The preparation and submission of shop drawings, procedures, and other required submittals, with a planned duration that is to be demonstrated to the Engineer as reasonable.
8. The review and return of shop drawings, procedures, and other required submittals, approved or with comments, the duration of which shall be thirty (30) Calendar Days, unless otherwise specified or as approved by the Engineer.
9. Procurement of fabricated materials and equipment with long lead times, including time for review and approval of submittals required before procuring and fabricating.
10. Each component of the Work defined by specific activities.
11. Right-of-Way (ROW) takings that have been identified in the Contract.
12. Early Utility Relocation (by others) that has been identified in the Contract.
13. Interfaces with adjacent work, utility companies, other public agencies, sensitive abutters, and/or any other third-party work affecting the Contract.
14. Utility work to be performed in accordance with the Project Utility Coordination (PUC) Form as provided in Section 8.14 - Utilities Coordination, Documentation and Monitoring Responsibilities
15. Access Restraints – restrictions on access to areas of the Work that are defined by the Department in the bid package, in Subsection 8.06 – Limitations of Operations or elsewhere in the Contract
16. Limitations of Work – time of year restrictions and any other limitations identified in the contract
17. Traffic work zone set-up and removal, night work and phasing
18. Material Certifications
19. Milestones listed in Subsection 8.03 - Prosecution of Work or elsewhere in the Contract Documents
20. For Type A and B Contracts only: All items to be paid for, including all Unit Price and Lump Sum pay items, shall be identified by activity. This shall include all non-construction activities such as engineering work; purchase of permanent materials and equipment, purchase of structural steel stock, equipment procurement, equipment delivery to the site or storage location and the representative amount of overhead/indirect costs that was included in the Contractor's Bid Prices.

**SECTION 722** (Continued)

21. Contractor's request for validation of FBU (ready to open to traffic)
22. Full Beneficial Use (FBU) Contract Milestone per the following requirements:  
The majority of contract Work has been completed and the asset(s) has been opened for full multi-modal transportation use, except for limited contract work items that do not materially impair or hinder the intended public use of the transportation facility. All anticipated lane takings have been completed, except for minor, short term work items and as defined in Subsection 8.03 - Prosecution of Work
23. The Department's confirmation of completed work to allow for FBU.
24. Contractor's request for validation of Substantial Completion
25. Department generated punch list of twenty-one (21) Calendar Days
26. Substantial Completion Contract Milestone as defined in the standard specifications.
27. Punch list Completion Period of at least thirty (30) Calendar Days per the requirements of Subsections 5.11 - Final Acceptance, 7.15 - Claims Against Contractors for Payment of Labor, Materials and Other Purposes
28. Contractor confirmation that all punchlist work and documentation has been completed.
29. Physical Completion of the Work Contract Milestone per the requirements of Subsections 5.11 - Final Acceptance and 8.03 - Prosecution of Work
30. Documentation Completion per the requirements of Subsections 5.11 - Final Acceptance and 8.03 - Prosecution of Work
31. Contractor Field Completion Contract Milestone (which can also be considered the completion date) per the following requirements: All physical contract Work is complete including punchlist. The Contractor has fully de-mobilized from field operations and as defined in Subsection 5.11

**C. EARLY AND LATE DATES**

Early Dates shall be based on proceeding with the Work or a designated part of the Work exactly on the date when the corresponding Contract Time commences. Late Dates shall be based on completing the Work or a designated part of the Work exactly on the corresponding Contract Time, even if the Contractor anticipates early completion.

**D. DURATIONS**

Activity durations shall be in Work Days. Planned Original Durations shall be established with consideration of resources and production rates that correspond to the Contractor's Bid Price. Within all of the Department-required schedules, the Contractor shall plan the Work using durations for all physical construction activities of no less than one (1) Work Day and no greater than fourteen (14) Work Days, unless approved by the Engineer as part of the Baseline Schedule Review.

---

**SECTION 722** (Continued)

Should there be an activity with a duration that is determined by the Engineer to be unreasonable, the Contractor will be asked to provide a basis of the duration using bid documents, historic production rates for similar work, or other form of validation that is acceptable to the Engineer. Should the Contractor and the Engineer be unable to agree on reasonable activity durations, the Engineer will, at a minimum, note the disagreement in the Baseline Schedule Review along with a duration the Engineer considers reasonable and the basis for that duration. A schedule that contains a substantial number of activities with durations that are deemed unreasonable by the Engineer will not be accepted.

**E. MATERIALS ON HAND**

The Contractor shall identify in the Baseline Schedule all items of permanent materials (Materials On Hand) for which the Contractor intends to request payment prior to the incorporation of such items into the Work.

**F. ACTIVITY DESCRIPTIONS**

The Contractor shall use activity descriptions in all schedules that clearly describe the work to be performed using a combination of words, structure numbers, station numbers, bid item numbers, work breakdown structure (WBS) and/or elevations in a concise and compact label.

**G. ACTIVITY IDENTIFICATION NUMBERS**

The Contractor shall use the activity identification numbering system specified in the MassDOT Highway Division Contractor Construction Schedule Toolkit.

**H. ACTIVITY CODES**

The Contractor shall use the activity codes specified in the MassDOT Highway Division Contractor Construction Schedule Toolkit.

**I. CALENDARS**

Different calendars may be created and assigned to all activities or to individual activities. Calendars define the available hours of work in each Calendar Day, holidays and general or project-specific non-Work Days such as Fish Migration Periods, time-of-year (TOY) restrictions and/or area roadway restrictions. All calendars shall extend two years beyond the current project completion date.

Project Special Provisions identify specific calendar restrictions some examples of special calendars include, but are not limited to:

- Winter Shutdown Period, specific work is required by separate special provision to be performed during the winter. See Special Provision 8.03 (if applicable)
- Peak traffic hours on heavily traveled roadways. This shall be from 6:30 am to 9:30 am and from 3:30 pm to 7:00 pm, unless specified differently elsewhere in the Contract.
- Special requirements by sensitive abutters, railroads, utilities and/or other state agencies as defined in the Contract.
- Planting seasons for trees, shrubs and grasses and wetlands mitigation work.

**SECTION 722** (Continued)

- Cape Cod and the Islands Summer Roadway Work Restrictions: A general restriction against highway and bridge construction is enforced between Memorial Day and Labor Day, unless otherwise directed by the Engineer. Cape Ann Summer Roadway Work Restrictions: While there are no general restrictions for Cape Ann as there are for Cape Cod and the Islands, project-specific restrictions may be enforced.
- Turtle and/or Fish Migration Periods and/or other in-water work restrictions: Refer to the Project Special Provisions for specific restrictions.
- Working over Waterways Restricted Periods.
- Night-time paving and striping operations, traffic, and temperature restrictions.
- Utility Restrictions shall be as specified within the Contract.

**J. FLOAT**

For the calculation of float in the CPM schedule, the setting for *Retained Logic* is required for all schedule submissions, starting with the Baseline Schedule Submission. Should the Contractor have a reason to propose that an alternative calculation setting such as *Progress Override* be used, the Contractor shall obtain the Engineer's approval prior to modifying to this setting.

**K. COST AND RESOURCE LOADING (Types A and B only)**

For all Type A and B Schedules, the Contractor shall provide a cost and resource-loaded schedule with an accurate allocation of the costs and resources necessary to complete the Work. The costs and resources shall be assigned to all schedule activities in order to enable the Contractor to efficiently execute the Contract requirements and the Engineer to validate the original plan, monitor progress, provide cash flow projections, and analyze delays.

1. Each schedule activity shall have an assigned cost that accurately represents the value of the Work. Each schedule activity shall have its resources assigned to it by craft and the anticipated hours to accomplish the work. Each schedule activity's equipment resources shall be assigned to it by equipment type and hours operated. Front-loading or other unbalancing of the cost distribution will not be permitted.
2. The sum of the cost of all schedule activities shall be equal to the Contractor's Bid Price.
3. Indicating the labor hours per individual, per day, by craft and equipment hours/day will be acceptable.
4. The Engineer reserves the right to use the cost-loading as a means to resolve changes, disputes, time entitlement evaluations, increases or decreases in the scope of Work, unit price renegotiations and/or claims.
5. For all Type A and B Schedules, all subnets, fragnets, Proposal Schedules, and Recovery Schedules shall be cost and resource-loaded to help to quickly validate and monitor the duration of the Work to be performed.
6. For Type A Schedules, cost-loading of the schedule will also be used for cash flow projection purposes.
7. The cost-loading of each activity shall indicate the portion of the cost for that activity that is applicable to a specific bid item (cost account.) The total cost for each cost account must equal the bid item price.

**SECTION 722** (Continued)**L. NOT TO BE USED IN THE CONTRACTOR'S CPM SCHEDULE**

1. Milestones or constraint dates not specified in the Contract.
2. Scheduled work not required for the accomplishment of a Contract Milestone
3. Use of activity durations, logic ties and/or sequences deemed unreasonable by the Engineer.
4. Delayed starts of follow-on trades.
5. Float suppression techniques.
6. Leads such as leads, lags, SS, SF, & FF relationships without the expressed permission of the Department.

**722.62 Submittal Requirements**

All schedules shall be prepared and submitted in accordance with the requirements listed below.

Each monthly Contract Progress Schedule submittal shall be uniquely identified.

Each Submission shall, at a minimum, include the following:

- a. Narrative
- b. Schedule submittals shall be signed by the Scheduler
- c. Schedule Printout - All Activities
- d. Schedule Printout - Critical Path Layout
- e. Schedule Printout - Remaining Work
- f. Schedule Printout - Top 3 Float Path
- g. Work Breakdown Structure (WBS) Summary
- h. Project Spending Report (PSR) in Portable Document Format (.PDF)
- i. Project Spending Report (PSR) in Microsoft Excel spreadsheet (.XLS)
- j. Oracle Primavera P6 Schedule File (.XER)

All digital file submittals will be labeled with the following information.

- Contract Number
- Project Number
- Project locations (i.e., town(s))
- Brief description
- Submittal description (i.e., UP07)
- Data Date (MM-DD-YY)
- File Description (i.e., Critical Path)

Example: C110464 (P606309) - Orange Route 2 over 202 – UP23 (07-15-22) - Critical Path

**A. Narratives**

A written narrative shall be submitted with every schedule submittal. The narrative shall:

1. itemize and describe the flow of work for all activities on the Critical Path in a format that includes any changes made to the schedule since the previous Contract Progress Schedule / Monthly Update or the Baseline Schedule, whichever is most recent.
2. provide a description of any specification requirements that are not being followed. Identify those that are improvements and those that are not considered to be meeting the requirements.



**SECTION 722** (Continued)

3. provide all references to any Notice of Delay that has been issued, within the time period of the Contract Progress Schedule Update, by letter to the Engineer. Note that any Notice of Delay that is not issued by letter will not be recognized by the Engineer. See Subsection 722.64.A – Notice of Delay.
4. provide a description of each third-party utility's planned vs. actual progress and note any that are trending late or are late per the durations and commitments as provided in the PUC Form; provide a description of the five (5) most important responses needed from the Department and the need date for the responses in order to maintain the current Schedule of Record.
5. provide a description of all critical issues that are not within the control of the Contractor or the Department (third party) and any impact they had or may have on the Critical Path.
6. provide a description of any possible considerations to improve the probability of completing the project early or on time.
7. compare Early and Late Dates for activities on the Critical Path and describe reasons for changes in the top three (3) most critical paths.
8. describe the Contractor's plan, approach, methodologies, and resources to be employed for completing the various operations and elements of the Work for the top three (3) most critical paths. For update schedules, describe and propose changes to those plans and verify that a Proposal Schedule is not required.
9. describe, in general, the need for shifts that are not 5 days/week, 8 hours/day, the holidays that are inserted into each calendar and a tabulation of each calendar that has been used in the schedule.
10. describe any out-of-sequence logic and provide an explanation of why each out-of-sequence activity does not require a correction, if one has not been provided, and an adequate demonstration that these changes represent the basis of how these activities will be built, including considerations for resources, dependencies, and previously approved production rates.
11. identify any possible duration increases resulting from actual or anticipated unit price item quantity overruns as compared to the baseline duration, with a corresponding suggestion to mitigate any possible delays to the Critical Path. If the delay is anticipated to impact the Critical Path, refer to Subsections 4.06 – Increased or Decreased Contract Quantities and 8.10 – Determination and Extension of Contract Time for Completion and submit a letter to the Engineer notifying of a potential delay.
12. include a schedule log consisting of the name of the schedule, the data date and the date submitted.
13. include and describe any notifications, communications and coordination meetings with third-parties such as utility companies that occurred from the last update including personnel names, job titles and contact information, date of meeting(s)/correspondence(s), topics discussed, and reasons the third party provided for deviations from the PUC form.

---

**SECTION 722** (Continued)**B. CPM Bar Charts**

One (1) timescaled bar chart containing all activities shall be prepared and submitted using a scale that yields readable plots and that meets the requirements of Subsection 722.61 – Schedule Content and Preparation Requirements. Activities shall be linked by logic ties and shown on their Early Dates. Critical Paths shall be highlighted, and Total Float shall be shown for all activities.

A second timescaled bar chart shall also be prepared containing only the Critical Path or, if the Critical Path is not the longest path, the Longest Path using a scale that yields readable plots and that meets the requirements of Subsection 722.61 – Schedule Content and Preparation Requirements. Activities shall be linked by logic ties and shown on their Early Dates. Total Float shall be shown for all activities.

**C. Detailed Activity Schedule Comparisons**

A Detailed Activity Schedule Comparison (DASC) is a simple reporting tool in the format of a graphical report that will provide Resident Engineers with immediate, timely and up-to-date information. The DASC consists of an updated bar chart that overlays the current time period's bar chart onto the previous time period's bar chart for an easily read comparison of progress during the present and previous reporting periods.

**D. Activity Cost Report and Monthly Cash Flow Projections (Type A only)**

With each Contractor Quantity Estimate (CQE), the Contractor shall submit an Activity Cost Report and Cash Flow Projection that includes all activities grouped by Contract Bid Item.

The Activity Cost Report shall be generated from the Schedule of Record and shall be the basis of the Monthly Cash Flow Projection. Within each contract Bid Item, activities shall be sequenced by ascending activity identification number and shall show:

1. activity ID and description,
2. forecast start and finish dates for each activity and,
3. when submitted as a revised schedule, actual start, and finish dates for each completed activity.
4. any variance to the estimated contract quantity shall be shown.

**E. Resource Graphs (Type A only)**

Monthly and cumulative resource graphs for the remaining Contract period using the Early Dates and Late Dates in the Contract Progress Schedule shall be included as part of each schedule submittal.

**SECTION 722** (Continued)**F. Projected Spending Reports**

A Projected Spending Report (PSR) shall be prepared and submitted monthly. The PSR shall indicate the monthly spending (cash flow) projection for each month from NTP to Contractor Field Completion (CFC). Each month's actual spending shall be calculated using all CQEs paid during that month. The Projected Spending Report (PSR) shall be depicted in a tabular format and provided in both an .XLS and .PDF.

**722.63. Progress Schedule Requirements****A. Baseline Schedule**

The Baseline Schedule shall be due thirty (30) Calendar Days after Notice to Proceed (NTP). The Baseline Schedule shall only reflect the Work awarded to the Contractor and shall not include any additional work involving Extra Work Orders or any other type of alleged delay. The Baseline Schedule shall be prepared and submitted in accordance with Subsections 722.61 - Schedule Content and Preparation Requirements and 722.62 - Submittal Requirements. Once the Baseline Schedule has been accepted by the Engineer, with or without comments, it shall represent the as-planned schedule for the Work and become the Contract Progress Schedule of Record until such time as the schedule is updated or revised under Subsections 722.63.C - Contract Progress Schedules / Monthly Updates, 722.64.C - Recovery Schedules and 722.64.D - Proposal Schedules.

The Cost and Resource-Loading information (Types A and B only) shall be provided by the Contractor within forty-five (45) Calendar Days after NTP.

The Engineer's review comments on the Baseline Schedule and the Contractor's responses to them will be maintained for the duration of the Contract and will be used by the Engineer to monitor the Contractor's work progress by comparing it to the Contract Progress Schedule / Monthly Update.

**B. Interim Progress-Only Schedule Submissions**

The first monthly update of the Contract Progress Schedule/Monthly Update is due within seventy (70) Calendar Days after Notice to Proceed (NTP.) The Baseline Schedule review period ends at sixty (60) Calendar Days after NTP, see Subsection 722.60.B - Schedule Reviews by the Department. If the Baseline Schedule has not been accepted within sixty (60) Calendar Days after NTP, an Interim Progress-Only Schedule shall be due within seventy (70) Calendar Days after NTP. The purpose of the Interim Progress-Only Schedule is to document the actual progress of all activities, including non-construction activities, from NTP until the Baseline Schedule is accepted.

**SECTION 722** (Continued)**C. Contract Progress Schedules / Monthly Updates**

The first Contract Progress Schedule shall be submitted by the Contractor no later than seventy (70) Calendar Days after NTP. The data date for this first Progress Schedule shall be two months (approximately sixty (60) Calendar Days) after NTP. Subsequent Progress Schedules shall be submitted monthly.

Each Contract Progress Schedule shall reflect progress up to the data date. Updated progress shall be limited to asbuilt sequencing and asbuilt dates for completed and inprogress activities. Asbuilt data shall include actual start dates, remaining Work Days and actual finish dates for each activity, but shall not change any activity descriptions, the Original Durations, or the Original Resources (as planned at the time of bid), without the acceptance of the Engineer. If any activities have been completed out-of-sequence, the Contractor shall propose new logic ties for affected in-progress and future activities that accurately reflect the previously approved sequencing. Alternatively, the Contractor may submit to the Engineer for approval an explanation of why an out-of-sequence activity does not require a correction and an adequate demonstration that the changes accurately represent how the activities will be built, including considerations for resources, dependencies, and previously approved production rates. Once approved by the Engineer, the Contractor may incorporate the changes in the next Contract Progress Schedule/Monthly Update with the affected activities clearly identified and explained in the Schedule Narrative.

No revisions to logic ties, sequence, description, or duration of future activities; or planned resource costs shall be made without prior approval by the Engineer.

Any proposed logic changes for in-progress or future activities shall be submitted to the Engineer for approval before being incorporated into a Contract Progress Schedule. The logic changes must be submitted using a Proposal Schedule or a schedule fragnet submission. Once approved by the Engineer, the Contractor may incorporate the logic in the next Contract Progress Schedule/Monthly Update with the affected activities clearly identified and explained in the Schedule Narrative.

For any proposed changes to the original sequence, description or duration of future activities, the Contractor shall submit to the Engineer for approval an explanation of how the proposed description or duration change reflects how the activity will be progressed, including considerations for resources and previously approved production rates. Any description or duration change that does not accurately reflect how the activity will be progressed will not be approved by the Engineer. Once approved by the Engineer, the Contractor may incorporate the changes in the next Contract Progress Schedule/Monthly Update with the affected activities clearly identified and explained in the Schedule Narrative.

Contract Progress Schedules that extend performance beyond the Contract Time or beyond any Contract Milestone shall not be approved by the Engineer. The Contractor shall submit a Recovery Schedule, or a Time Entitlement Analysis, if any Contract Progress Schedule/Monthly Update indicates a failure to meet the Contract Dates.

**SECTION 722** (Continued)**D. Short-Term Construction Schedule**

The Contractor shall provide a Short-Term Construction Schedule that details daily work activities, including any multiple shift work that the Contractor intends to conduct, in a spreadsheet format. The daily activities shall directly correspond to the Contract Progress Schedule activities, with a matching reference to the activity identification number in the Contract Progress Schedule and may be at a greater level of detail. The Short-Term Construction Schedule shall be submitted every two weeks. It shall display all work for a thirty-five (35) Calendar Day period consisting of completed work for the two (2) week period prior and all planned work for the following three (3) week period. The initial submission shall be provided no later than thirty (30) Calendar Days after NTP or as required by the Engineer.

The Contractor shall be prepared to discuss the Short-Term Construction Schedule, in detail, with the Engineer in order to coordinate field inspection staff requirements, the schedule of work affecting abutters and any corresponding work with affected utilities. Short-Term Construction Schedules shall be prepared and submitted in accordance with Subsections 722.61 - Schedule Content and Preparation Requirements and 722.62 - Submittal Requirements.

**722.64 Impacted Schedule Requirements****A. Notice of Delay**

The Contractor shall notify the Engineer in writing, with copies to the District and State Construction Engineers, within fifteen (15) of the start of any delays to the Critical Path that are caused by actions or inactions that were not within the control of the Contractor. Delay notifications that are not provided in a letter to the Engineer, such as a delay notification in the schedule narrative, will not be recognized as contractual notice in the determination of any Time Extension related to the impacts to the work associated with this specific alleged delay. Should such a delay continue for more than one (1) week, the Contractor shall note it in the Schedule Narrative until the delay is no longer impacting the Critical Path for the completion of the Contract Milestones. The Engineer will evaluate the alleged delay and its impact and will respond to the Contractor within ten (10) Calendar Days after receipt of a notice of delay.

**B. Time Entitlement Analysis**

A Time Entitlement Analysis (TEA) shall consist of a descriptive narrative, prepared in accordance with Subsection 722.62.A - Narratives, and an as-built CPM schedule, which may be in the form of a schedule fragnet that has been developed from the project's Contract Progress Schedule of Record, and illustrates the impact of a delay to the Critical Path, Contract Milestones and/or Contract Completion Date as required in Subsection 8.10 - Determination and Extension of Contract Time for Completion. TEAs shall also be used to determine the schedule impact of proposed Extra Work Orders (EWO) as also required in Subsection 8.10.

TEAs shall be prepared and submitted in accordance with the requirements of Subsections 722.61 - Schedule Content and Preparation Requirements and 722.62 - Submittal Requirements and shall be based on the Contract Progress Schedule of Record applicable at the start of the delay or impact from an EWO. A TEA fragnet must start with a specific new activity describing the work contained in either a Notice of Delay previously submitted to the Department per Subsection 722.64.A - Notice of Delay or an EWO.

**SECTION 722** (Continued)

TEAs shall be submitted:

1. as part of any Extra Work Order that may impact Contract Time,
2. with a request for a Time Extension,
3. within fifteen (15) Calendar Days after a request for a TEA by the Engineer for any other reason.

A TEA shall be submitted to the Engineer before any Time Extension is granted to the Contractor. Time Extensions will not be granted unless the TEA accurately reflects an evaluation of all past delays and the actual events that occurred that impacted the Critical Path. The TEA must also demonstrate a plan for the efficient completion of all of the remaining work through an optimized CPM Schedule. The analysis shall include all delays, including Contractor-caused delays, and shall be subdivided into timeframes and causes of delays.

TEAs shall incorporate any proposed activities, logic ties, resource considerations, and activity costs required to demonstrate the schedule impacts most efficiently in addition to detailing all impacts to existing activities, logic ties, the Critical Path, Contract Milestones, and the Contract Completion Date. In addition, TEAs shall accurately reflect any changes made to activities, logic ties, restraints, and activity costs, necessitated by an Extra Work Order or other schedule impact, for the completion of the remaining work. The Contractor shall provide TEAs that demonstrate that all delays have been mitigated to the fullest extent possible without requiring an Equitable Adjustment to the original bid basis.

All TEAs shall clearly indicate any overtime hours, additional shifts and the resources that are proposed to be incorporated in the schedule. The Engineer shall have final discretion over the use of overtime hours and additional shifts. The Engineer shall have the right to require that overtime hours and/or additional shifts be used to minimize the duration of Time Extensions if it is determined to be in the best interest of the Department to do so.

When accepted, the changes included in a TEA shall be incorporated into the next Contract Progress Schedule per the requirements of Subsection 722.63.C - Contract Progress Schedules / Monthly Updates. During the review of any TEA, all Contract Progress Schedules shall continue to be submitted as required.

The Engineer may request that the Contractor prepare a Proposal Schedule or a Recovery Schedule to further mitigate any delays that are shown in the accepted TEA or Contract Progress Schedule.

**C. Recovery Schedules**

The Contractor shall promptly report to the Engineer all schedule delays during the prosecution of the Work. Contract Progress Schedules that predict performance extended beyond the Contract Time or beyond any Contract Milestone shall not be approved as the schedule of record. This requirement is critical to the Department's ability to make informed decisions regarding Contract Time and costs.

The Contractor shall submit a Recovery Schedule within fifteen (15) Calendar Days of a Contract Progress Schedule submission that shows failure to meet the Contract Dates unless a recovery schedule is waived by the Department. Waiving the recovery schedule does not relieve the contractor of the responsibility for the delay. The Department may revoke the waiver of a Recovery Schedule, at which time a Recovery Schedule shall be submitted within fifteen (15) Calendar Days of the Contractor being notified.

Changes represented in accepted Recovery Schedules shall be incorporated into the next Contract Progress Schedule.

---

**SECTION 722** (Continued)**D. Proposal Schedules**

A Proposal Schedule is an alternative schedule used to evaluate proposed changes to the Contract scope or significant alternatives to previously approved approaches to complete the Work, which may include changes to activity durations, logic, and sequence. For Types A and B Schedules, the Proposal Schedule shall be cost and resource loaded.

A Proposal Schedule may be requested by the Department at any time or may be offered by the Contractor. The Engineer may request that the Contractor prepare a Proposal Schedule to further mitigate any delays that are shown in an accepted TEA or Contract Progress Schedule.

The Contractor shall submit the Proposal Schedule within thirty (30) Calendar Days of a request from the Department.

The Proposal Schedule shall not be considered a Schedule of Record until the logic, durations, narrative, and basis of the Proposal Schedule have been accepted by the Engineer. If the Proposal Schedule took the form of a fragnet, it must be incorporated into the Contract Progress Schedule of Record showing the current progress of all other activities and the impacts/results of the changes made by the Proposal Schedule before the Proposal Schedule is accepted by the Department.

Proposal Schedules shall clearly indicate any proposed acceleration including overtime hours, additional shifts, and the resources that are proposed to be incorporated in the schedule. The Engineer shall have final discretion over the use of overtime hours and additional shifts. Proposal Schedules that contain a cost element shall be submitted with a separate Cost Proposal.

Changes represented in the accepted Proposal Schedules shall be incorporated into the next Contract Progress Schedule. During the review of any Proposal Schedule, all Contract Progress Schedules shall continue to be required every month.

**E. Disputes**

All schedules shall be submitted, reviewed, dispositioned, and accepted in the timely manner specified herein so as to provide the greatest possible benefit to the execution of this Contract.

The Contractor may dispute a decision by the Engineer by filing a claim notice within seven (7) days after the Contractor's request for additional time has been denied or if the Contractor does not accept the number of days granted in a time extension. The Contractor's claim notice shall include a revised time entitlement analysis that sufficiently explains the basis of the time-related claim. Failure to submit the required time entitlement analysis with the claim notice shall result in denial of the Contractor's claim. A determination on the Contractor's claim shall be in accordance with Subsection 7.16 Claims of Contractor for Compensation. Pending resolution of any dispute, the last schedule accepted by the Engineer will remain the Contract Schedule of Record.

---

**SECTION 722** (Continued)**722.65 Schedule Type D Requirements**

This section is to detail the requirements for Type D Schedules and is separate from the requirements listed above. These schedules are intended for a project in which a more formal schedule would not be practical.

Schedules for Type D projects shall be submitted for each work assignment. The Schedule Type D shall be submitted electronically in .XLS and .PDF format and meet the following requirements.

The schedule requirements for work assignments that are anticipated to last three weeks or less shall conform to the requirements for Short-term Construction Schedules below.

Work assignments that are anticipated to last longer than three weeks shall submit a bar chart baseline and provided update schedules upon request of the engineer as required under Bar Chart Schedule below in addition to meeting the Short-term Construction schedule requirements.

**A. Bar Chart Schedule**

A Bar Chart that shall include the following:

- Work Assignment start date.
- Activities to identify.
  - Major work operations broken down to be no longer than 14 days.
  - Procurement of fabricated materials and equipment with long lead times, including time for review and approval of submittals required before procuring and fabricating.
  - The preparation and submission of shop drawings, procedures, and other required submittals, with a planned duration that is to be demonstrated to the Engineer as reasonable.
  - The review and return of shop drawings, procedures, and other required submittals, approved or with comments, the duration of which shall be shown as thirty (30) Calendar Days,
  - Detailed activities to satisfy permit requirements.
  - Subcontractor approvals at fifteen (15) Calendar Days from submittal to response
  - Project Close out activities including a 21-calendar day creation of a punchlist activity and 30 calendar day minimum completion of punchlist activity.
- Interfaces with adjacent work, utility companies, other public agencies, sensitive abutters, and/or any other third-party work affecting the Contract.
- Access Restraints – restrictions on access to areas of the Work
- Traffic work zone set-up and removal, night work and phasing
- Contract Milestones including Full beneficial Use, Substantial Completion and Contractor Field Completion

The Bar Char Schedule shall be provided at the beginning of the project and updated with each work order created for the project.



**SECTION 722** (Continued)**B. Short-Term Construction Schedule**

The Contractor shall provide a Short-Term Construction Schedule that details daily work activities, including any multiple shift work that the Contractor intends to conduct, in a spreadsheet format. The daily activities shall directly correspond to the Contract Progress Schedule activities, with a matching reference to the activity identification number in the Contract Progress Schedule and may be at a greater level of detail. See schedule toolkit for suggested format.

The Short-Term Construction Schedule shall be submitted every two weeks. It shall display all work for a thirty-five (35) Calendar Day period consisting of completed work on the assignment for the two week period prior and all planned work for the following three week period. The initial submission shall be provided no later than thirty (30) Calendar Days after NTP or as required by the Engineer.

The Contractor shall be prepared to discuss the Short-Term Construction Schedule, in detail, with the Engineer in order to coordinate field inspection staff requirements, the schedule of work affecting abutters and any corresponding work with affected utilities.

**C. Project Spending Report (PSR)**

A Projected Spending Report (PSR) shall be prepared and submitted monthly. The PSR shall be for all active work assignments, broken down by work assignment. The PSR shall indicate the monthly spending (cash flow) projection for each month from NTP to Contractor Field Completion (CFC). Each month's actual spending shall be calculated using all CQEs paid during that month. The Projected Spending Report (PSR) shall be depicted in a tabular format and provided in both an .XLS and .PDF

**SECTION 722** (Continued)**COMPENSATION****722.80 Method of Measurement****Schedule of Operations (Type A, B and C)**

The project bid documents specify the fixed-price amounts to be paid to the Contractor for the Project Schedule requirements contained herein. Each bidder shall include this fixed price bid item amounts in their bid. Failure to do so may be grounds for the rejection of the bid.

This fixed price amount is for payment purposes only and is separate from what the Department considers to be the Contractor's General Condition costs. If the Contractor deems it necessary to include additional costs to provide all of the requirements of this section, these additional costs shall be included in the Contractor's overall bid price.

All required schedule-related work, including, but not limited to computers, computer software, the planning and coordination with utilities, training, schedule preparation and schedule submittals will be paid for under the fixed price amount.

Twenty percent (20%) of this pay item will be paid upon the Engineer's acceptance of the Contractor's Baseline Schedule, prepared and submitted in accordance with Subsection 722.63.A.

The remaining eighty percent (80%) of this pay item will be paid in equal monthly installments distributed across the Contract Duration from Notice to Proceed (NTP) to Contractor Field Completion (CFC), less the 2 months required for the submittal and review of the Baseline Schedule in accordance with the following formula:

$$\text{Monthly Payment} = \frac{\text{Remaining Fixed Price amount (80\% of the Item Cost.)}}{\text{Contract Duration in whole months} - 2 \text{ months}}$$

The Schedule of Operations pay item will be adjusted to pay for only the actual quantity of schedules that have been submitted in accordance with this section.

Should there be a Time Extension granted to the Contractor, the Engineer may provide an Equitable Adjustment for additional Contract Progress Schedule Updates at intervals directed by the Engineer. The monthly payment will be the basis for this Equitable Adjustment.

**Schedule of Operations (Type D)**

For projects assigned with Type D schedule requirements, all scheduling work shall be considered incidental to the project with no separate payment under this section.

**SECTION 722** (Continued)

**722.81 Basis of Payment**

The timely and accurate submission of the Baseline Schedule is critical to the Contract and the Department’s ability to make informed decisions. Only payments under Item 740 - Engineer’s Field Office and Item 748 – Mobilization will be made until the Baseline Schedule is accepted by the Engineer.

All required schedule-related work, including, but not limited to computers, computer software, the planning and coordination with utilities, training, schedule preparation and schedule submittals (including monthly progress schedules, short-term schedules, project spending reports, TEAs, recovery schedules or impacted schedules) shall be included in this work.

No payment for any other pay item will be processed beyond seventy-five (75) Calendar Days from Notice to Proceed (NTP) until the Baseline Schedule is accepted by the Engineer. Until the Engineer’s acceptance of the Baseline Schedule, the combined total of all payments made to the Contractor will be limited to an amount no greater than the total price for Item 748 - Mobilization or 3% of the contract price, whichever is less.

All Contract Progress Schedule Updates submitted later than ten (10) Calendar Days after the CQE (Contract Quantity Estimate) completion date, or greater than forty (40) Calendar Days from the Data Date of the previous submission, will be deemed to be no longer useful and will not qualify for payment. The late submission of Impacted schedules, including TEAs, recovery schedules and proposal schedules will result in the forfeiture of the monthly payment for the month in which they were due and subsequent months until the submission is made. Late submission of missed submittals will not result in recovery of the previously forfeited portion of the Schedule of Operations Fixed Price Payment Item.

Failure to submit schedules as and when required may result in the forfeiture of that portion of the Schedule of Operations Fixed Price Payment and/or the withholding of the full or partial CQE payments by the Engineer.

Failure to submit schedules that are acceptable to the Engineer may result in the forfeiture of that portion of the Schedule of Operations Fixed Price Payment and/or the withholding of the full or partial CQE payments by the Engineer.

The Schedule of Operations pay item will be adjusted to pay for only the actual quantity of schedules that have been submitted in accordance with this section.

The Contractor's failure or refusal to comply with the requirements of this Section shall be reasonable evidence that the Contractor is not prosecuting the Work with due diligence and may result in the Engineer withholding of full or partial payments of all work performed.

**722.82 Payment Items**

- 722.1 SCHEDULE OF OPERATIONS (TYPE A) - FIXED PRICE \$ \_\_\_\_\_ LUMP SUM
- 722.2 SCHEDULE OF OPERATIONS (TYPE B) - FIXED PRICE \$ \_\_\_\_\_ LUMP SUM
- 722.3 SCHEDULE OF OPERATIONS (TYPE C) - FIXED PRICE \$ \_\_\_\_\_ LUMP SUM

**SCHEDULE OF OPERATIONS - SCHEDULE TYPE**

The applicable schedule type for this project is Type D.

**ITEM 100.1****BASE LABOR RATE****HOUR**

The Contractor will furnish competent artisans, possessing all pertinent licenses and/or certifications, as required by the Engineer, to maintain and repair various components of the bridges as they relate to the work that has not been included in any other Contract bid Items. The Contractor shall submit to the Engineer all pertinent licenses and/or certifications for each artisan prior to the commencement of any work.

The payment under this Item will only be for the time spent by artisans only on the project.

Payment will be based upon time spent on the project doing actual work assigned by the Engineer and shall NOT include travel time to and from the Contractor's place of business and it shall also not include time for investigative field trips.

Payment for equipment (other than the usual artisan toolbox) will be made under payment for equipment rental as stated elsewhere in these special provisions.

This Item shall only be used to compensate the Contractor for the time that their in-house workforce spends on work orders assigned by the Engineer.

Incidental to this item, vehicles are to be supplied for each artisan. If more than one artisan of a certain type (for example, carpenter) are working at a work site, the Contractor need only supply the minimum vehicles required to transport the artisans, their equipment, laborers, materials, and supplies. The artisan vehicle(s) shall be capable of transporting materials consistent with the trade. It is the intent under this item for material deliveries to be reimbursable only for bulk items or materials of sufficient quantity as determined by the Engineer. The Contractor shall make his bid with the understanding that ownership and operating costs do not apply and are not reimbursable for the vehicles utilized under the artisan items.

Described below, and included in this item, will be a tool kit for each trade with all incidental tools, special apparel, and any required personal safety equipment and a vehicle for each trade with no additional charge to the Department.

All tools and equipment in artisans' toolboxes shall be in excellent working condition.

If a separate tool truck is utilized, such vehicle shall also be considered incidental to this item.

Any Additional vehicles the Engineer deems necessary will be paid for under the rental equipment item. If it is the Contractor's policy for the artisan to use their personal vehicles for the above purposes, no additional vehicles are required.

Artisans and toolboxes are described below:

---

**ITEM 100.1** (Continued)**Laborer**

Small hand tools, hand held power tools, chipping hammer, eye shields, gloves, protective clothing, generators as necessary to run the equipment and equipment that is normally used in the trade.

**Carpenter**

Hammer, framing square, tape measure, pouch, levels, hand saws, power saws, all electric power tools, air tools and generators and compressors as necessary to run the equipment. Saw blades and drill bits are also included.

**Cement Mason**

All trowels, floats, chipping hammers, wire brushes, trowels, floats, reinforcing tie wires, mortar boards, jointing tools and buckets, mortar board and mixing tub/buckets, and other hand tools as necessary to complete masonry patching work.

**Ironworker / Welder**

Spud wrench, dowels, alignment pins, tape measure, pouch, levels, eye shields, gloves, protective clothing, rivet buster, air hammer, jackhammer, reamers, chipping hammer, wire brushes AC/DC-300 amp-100% duty cycle (minimum size) welding machine, torches for cutting, burning, or preheating steel, including fuel tanks & fuel / oxygen, grinders, heating oven for all welding consumables and other equipment that is normally used in the trade.

**Equipment Operator Backhoe/Front-End Loader**

Operator shall have all the licenses and certifications required by the Commonwealth of Massachusetts for the equipment he/she will be operating. Operators shall be in possession of their licenses at all times and show it to the Engineer when requested. Equipment included but not limited to a backhoe and front-end loader.

Equipment which does not require a special licenses or certification for its operation shall be considered incidental to the artisan using it.

**DAILY FORCE ACCOUNT REPORT - (Form CSD-123)**

The Contractor will be required to submit a signed "Daily Force Account Report" or similar acceptable form, for each day he is performing work under this pay Item.

The form should contain number and type of workmen, actual hours on jobsite for each, hours identified as regular or overtime, work location, a significant description of work accomplished including square feet or linear feet of material applied and Sub-Contractor men and accomplishments.

**ITEM 100.1** (Continued)

**METHOD OF MEASUREMENT**

Item 100.1 will be measured for payment by the Hour.

The Engineer will calculate total Base Labor Rate hours spent on the project by artisans.

Overtime hours will be paid for work exceeding eight (8) consecutive hours per day or forty (40) hours per week and shall be compensated as specified in this Item.

To calculate the total Base Labor Rate hours, the Engineer will modify hours spent by various artisans on the project using adjustment factor(s) described below:

<b><u>COMPENSATION FACTORS</u></b>		
<b><u>ARTISAN</u></b>	<b><u>REGULAR</u></b>	<b><u>OVERTIME</u></b>
LABORER	1.00	1.30
CARPENTER	1.11	1.44
CEMENT MASON	1.24	1.61
IRON WORKER / WELDER	1.15	1.50
EQUIPMENT OPERATOR	1.10	1.43

If an artisan has an apprentice, then that apprentice’s compensation factor shall be 80 percent of the artisan’s.

The Compensation Factors above will be used to adjust the number of hours a specific artisan will be paid for, per one (1) hour of work.

**Example:**

If the time spent on this project by various artisans is:

- Laborer                8 hrs.
- Carpenter            4 hrs
- Cement Mason       6 hrs

then the total hours for “Base Labor Rate” will be calculated as follows:

$$\begin{aligned}
 & \text{“Artisan A(hrs.)”} \times \text{“Compensation Factor A”} + \\
 & \text{“Artisan B(hrs)”} \times \text{“Compensation Factor B”} + \\
 & \text{“Artisan C(hrs)”} \times \text{“Compensation Factor C”}
 \end{aligned}$$

$$\begin{aligned}
 & 8(\text{hr}) \times 1.00 + 4(\text{hr}) \times 1.11 + 6(\text{hr}) \times 1.24 = \\
 & 8.00(\text{hr}) + 4.44(\text{hr}) + 7.44(\text{hr}) = 19.88 (\text{hr})
 \end{aligned}$$

In the above example, the total hours for “Base Labor Rate” is 19.88 hours (billable hours).

**ITEM 100.1** (Continued)

**BASIS OF PAYMENT**

Item 100.1, Base Labor Rate, will be paid for at the Contract unit bid price per Hour, which price shall include all equipment and tools required to perform the normal artisans work. All clothing or safety equipment normally associated with the artisans work is also considered incidental to this item.

Any transportation required for an artisan and their toolbox to travel to and from a job site will be incidental to the work. Ownership and operating costs, fuel and maintenance are not reimbursable for the vehicles and tools utilized under the artisan items.

**ITEM 102.21**                      **SELECTIVE CLEARING AND GRUBBING**                      **SQUARE YARD**

The work under this Item shall conform to the relevant provisions of Subsections 101 and 170 of the Standard Specifications supplemented with the following:

The work to be done under this item consists of clearing trees and shrubs outside the proposed parapet face of the wingwall and other selected areas required by the Engineer to provide access for repair, repainting, and inspection work.

All debris shall be removed and properly disposed from the site. This work shall include any required grading of the loamed areas and seeding in order to provide a stand of grass in the disturbed areas.

Trees and shrubs that interfere with the clear view of safety signs and existing signs within the limits of work shall be trimmed, as required by the Engineer. Trees and shrubs growing adjacent to or within the revetment under the bridges shall be removed, as required by the Engineer.

**METHOD OF MEASUREMENT**

Item 102.21 will be measured for payment by the Square Yard of selective clearing and grubbing of area where trimming or removal of trees and shrubs is to be performed.

**BASIS OF PAYMENT**

Item 102.21 will be paid for at Contract unit bid price per Square Yard, which price shall include all clearing, grubbing, trimming, grading, loam, seed, removal and disposal of debris, labor, materials, equipment, disposal and all incidental costs required to complete the work.



**ITEM 106.15****BLEEDER (BRIDGE DECK) PVC****EACH**

The work to be done under this item shall conform to the relevant provisions of Subsections 450 and 901 of the Standard Specifications, and the following.

The work to be done under this item consists of removal of the existing bridge deck weep drains and installing three new 3/4" inside diameter PVC deck bleeders at each location as required by the Engineer. The work shall be in accordance with the LRFD Bridge Manual, Drawing 7.9.1, dated April 2024.

This work includes excavating bituminous concrete pavement, removal of old deck bleeders and concrete around the old weep drain deck bleeders, installing new deck weep drains and concrete, furnishing and installing liquid membrane, hot mix asphalt for patching and galvanized screen at all bleeder locations on hot mix asphalt surfaced bridges.

Hot mix asphalt surfaces shall be excavated full-depth for an area measuring 1'-6" wide x 4'-0" length (minimum), or as required by the Engineer. Prior to excavation, the Contractor shall saw cut the hot mix asphalt full depth at the perimeter of the area with a concrete saw.

An area one foot wide and three-foot-long (minimum), or as required by the Engineer, shall be marked out around the existing weep drains, and a 1 inch deep saw cut made around the perimeter of the area to be removed. The concrete area shall be chipped out, full depth, in order to remove the old weep drains and any unsound or deteriorated concrete. The Contractor shall prevent any damage to any existing steel reinforcement, curbing, or structural steel during the concrete removal operation. All damage to the existing concrete which is to remain shall be repaired to a condition equal to that existing (prior to concrete removal) at the Contractor's expense.

The Contractor shall create a template and install the new PVC weep drains. It is preferred to have all straight pipe sections for the new weep drains. No bends shall be allowed greater than 22-1/2 degrees and no more than 2 bends shall be allowed per weep drain. It should be clarified that there are three separate weep drains included in the "per unit Each" Item at each location. The new weep drains shall be tied to the existing steel reinforcement on both the upper and lower steel reinforcement mats. Additional steel reinforcement may be installed in order to facilitate this requirement and be paid for under Item 910.1.

The Contractor shall coat the surface of the new concrete and sides of the hot mix asphalt excavation thoroughly with tar mastic. The concrete shall have cured and dried sufficiently prior to starting this operation. After placing the mastic, the Contractor shall place the galvanized screen over the bleeder hole and then dust the placed membrane with Portland cement. When the membrane has cooled, he shall fill the hot mix asphalt excavation to the existing (prior to excavating) line and grade. Placing and compacting of the hot mix asphalt for patching shall conform to the relevant provisions of Subsection 450. After compaction, hot poured rubberized joint sealer shall be placed along the gutter line for a minimum distance of five feet or as required by the Engineer, to seal along the curb line.

**ITEM 106.15** (Continued)

**METHOD OF MEASUREMENT**

Item 106.15 will be measured for payment by the Each location installation of three separate weep drains, complete in place.

**BASIS OF PAYMENT**

Item 106.15 will be paid for at the Contract unit price per Each, which price shall include all labor, materials, equipment, sawcutting, excavation, removal of old deck bleeders, installation of new deck weep drains and concrete, furnishing and installation of liquid membrane, hot mix asphalt for patching, tar mastic, galvanized mesh, and all incidental costs required to complete the work.

Additional steel reinforcement will be paid for under Item 910.1 Steel Reinforcement for Structures – Epoxy Coated.

**ITEM 106.151**

**PVC DRAINPIPE EXTENSIONS**

**EACH**

The work to be done under this item shall conform to the relevant provisions of Subsections 230 and 901 of the Standard Specifications and the following.

Work under this item consists of reinstalling the missing PVC drain pipe extensions with new PVC drain pipe extensions and in accordance with Section M5.03.7 of Standard Specifications as required by the Engineer.

The work shall include clamps, grouting, vertical adjustments, and bends as required by the Engineer.

The intent is for the drains to extend below the bottom of the bridge beams and direct water away from any portion of the bridge.

**METHOD OF MEASUREMENT**

Item 106.151 will be measured for payment per Each PVC drain pipe extension installed.

**BASIS OF PAYMENT**

Item 106.151 will be paid at the contract unit price per Each, which price shall include all materials, labor, equipment, and all incidental costs required to complete the work.

**ITEM 106.88****JACKING AND SHORING****EACH**

The work under this item consists of jacking and supporting existing beams/girders as required by the the Engineer.

Shoring materials may be new or second hand. The Contractor shall submit a plan of the proposed work showing the details and indicating the materials to be used. The submittal shall include the jacking load calculations and shoring design computations, based on the bridge configurations and the working stresses of the materials used, sequence of operations, and all details incidental thereto. Unless otherwise required by the Engineer, the proposed jacking and shoring system shall be designed to apply force in increments to the existing beam/girder to relieve load from the existing substructure. The jack(s) shall have a locking mechanism preventing the beam/girder from lowering in the event of loss of hydraulic pressure. All components of the system shall have load capacity greater than the total calculated load carried by the existing beam/girder during normal traffic operation, which includes but not limited to, dead load, live load, and impact load.

Bridge Loads: The Contractor shall be responsible for calculating loads (live and impact loads, dead loads...etc.) necessary to design shoring paid under this Item. All materials (except jacks) shall be designed by working stress design (ASD). Type of jacks used, and factor of safety shall be per industry standards.

Approval of this submission shall be obtained prior to the commencement of any work under this item. The above plan and computations shall bear the seal and signature of a Professional Engineer of the appropriate discipline registered in Massachusetts.

Materials shall meet the following:

Wood Products:	M9.05.1
Anchor Bolts, Nuts and Washers:	M8.01.5
Structural Steel:	M8.05.0

The Contractor shall remove and retain ownership of all materials and items furnished by him and that are not part of the permanent structure, unless other prior arrangements are made with the Engineer for MassDOT to purchase all or some of the shoring elements.

All treated wood supplied by the Contractor shall meet the requirements of M9.05.1 for Wood Products, including the most recent versions of AWPA U1 and M4 which are incorporated by reference. No new wood shall be treated with inorganic arsenic (including chromated copper arsenate (CCA), ammoniacal copper arsenate (ACA), and ammoniacal copper zinc arsenate (ACZA)), creosote or pentachlorophenol in all project construction.

The Contractor is alerted that some of the beams/girders may have been temporarily shored by MassDOT personnel or by others. At such locations, the Contractor shall install a jacking support system before removing any temporary supports. The cost of removing and stacking of the temporary supports at an on-site location, as required by the Engineer, shall be considered incidental work hereunder with no additional compensation.

**ITEM 106.88** (Continued)

When required by the Engineer extensive repairs require temporarily supporting some of the beams/girders on one or both sides of a pier cap(s), or abutment(s) those beams/girders shall be jacked/shored all at once as one unit for the length of time required.

The work shall be performed as follows:

Erect supports under each beam/girder as required by the Engineer. When possible, all supports shall be located 4'-0" from the centerline of each corresponding pier or centerline of bearing at each corresponding abutment. The cribbing for the support footings shall be of a sufficient size so as to prevent any settlement or damage to the footings while the superstructure is being adequately supported as required by the Engineer.

The successful prosecution, safety, and completion of the work in an acceptable manner are the responsibility of the Contractor. In the event of any damage to the structure due to inadequate supports, or Contractor's operations, the Contractor shall repair or replace any such damaged components at no cost to the department. The support of the beams/girders shall remain in place until all work is completed as required by the Engineer.

When the repairs are completed and the supports are no longer needed as determined by the Engineer, all supporting materials shall be removed and become the property of the Contractor, unless other prior arrangements were previously made with MassDOT.

Each bridge will be kept open to traffic while the beams/girders are supported. The Contractor's attention is directed to the fact that the expressways and some other roads are heavily traveled high-speed roads with high volumes of truck traffic.

Some of the bridges in District 2 are over water and may require a shoring plan that is beyond typical. In those cases, any equipment required, and approved by the Engineer prior to use, that is needed to place the shoring, or any additional time needed during set-up or attachment of shoring will be compensated under the non-bid items.

Bid pricing for this Item should be predicated on a typical shoring design. Additional costs associated with designing and placing shoring in water will be allowed under the appropriate non-bid allowances at the discretion of the Engineer.

**METHOD OF MEASUREMENT**

Item 106.88 will be measured for payment by the Each steel or concrete beam/girder end jacked and shored as required by the Engineer. Multiple jacking of the same end for the same repair will not be measured separately.

**BASIS OF PAYMENT**

Item 106.88 will be paid for at the Contract unit price per Each, which price shall include all labor, materials, tools, equipment, engineering services, and all incidental costs required to complete the work.

Placement of shoring that is required to support a pier cap during the repair of a pier column will also be compensated under this Item.

**ITEM 106.881**      **JACKING AND SHORING REMOVED AND RESET**      **EACH**

When an assigned work location requires more than one shoring tower and one or more of those towers can be reset at a subsequent repair within the same work location after the initial repair has been completed, those tower(s) shall be removed and reset to the new location as required by the Engineer. It is not intended for this item to be used when shoring towers are to be transported to a different work location. Bridges adjacent to each other will not be considered as different work locations.

**METHOD OF MEASUREMENT**

Item 106.881 will be measured for payment by the Each, jacking and shoring removed and reset.

**BASIS OF PAYMENT**

Item 106.881 will be paid for at the Contract unit price per Each, which price shall include all labor, materials, tools, equipment, disassembling the shoring unit, preparation of the bedding on which the tower will be reset, re-assembly of the shoring unit and placement of jack or shims as required, and all incidental costs required to complete the work.

**ITEM 107.97****STRUCTURAL STEEL REPAIRS****POUND**

The work under this Item shall conform to relevant provisions of Subsections 960 and 961 of the Standard Specifications and the following:

The work shall include designing, furnishing, fabricating, transporting, and erecting structural steel for repairing the deterioration of the structural steel beams as required by the Engineer. It shall also include replacing structural steel bracing, utility support, diaphragms, and engineering services.

The Contractor shall take all precautions necessary not to damage those portions of the superstructure that are to remain. Structural steel components damaged by the Contractor's operation shall be repaired in conformance with these specifications. The costs of such repairs shall be borne by the Contractor.

Structural steel repairs will include repairing deteriorated beam ends at locations as required by the Engineer; also, the in-kind replacement of deteriorated bracing and/or utility supports when deemed required by the Engineer. The final limits for each of the repairs and additional in-kind replacement will be provided by the Engineer, after cleaning and priming of the steel.

The Contractor shall submit to the Engineer a plan of the proposed repairs showing the details and indicating the materials he intends to use. The submittal shall include design computations based on all applicable loads (i.e., dead load, live load + impact, etc.), working stresses of the materials used, sequence of operations, and all details incidental thereto. All loads shall be calculated by the Contractor. Approval of this submission shall be obtained prior to the commencement of any work under this item. The above plan and computations shall bear the seal and signature of a Professional Engineer of the appropriate discipline registered in Massachusetts.

All work shall be done as required and approved by the Engineer and in accordance with the details and sequence of construction supplied by the Contractor and approved by the Engineer.

Conditions may also vary such that the repairs at each location will require some field measurements and fabrication to ensure proper fit. The Contractor shall satisfy their own investigation and research, regarding all conditions and materials affecting the work to be done. No additional compensation, other than the unit price bid for this item, will be made if the materials or work prove to be different than that inferred or described herein.

All costs for permits, dump fees, taxes, special handling of hazardous materials, etc., shall be included in the bid price for this item.

The Contractor shall note that certain repair locations are known to have obstacles that are in conflict with the work that is to be performed. Work required to move, remove, replace, protect, work around, or modify any obstacles interfering with the structural steel repair work, such as utilities, drainpipes, existing shielding, cables, and diaphragms, shall be included in this item and be performed with no additional compensation, and shall be deemed incidental to the unit price bid for this item.

**ITEM 107.97** (Continued)

The limits of the repairs are to be determined by the Contractor's Engineer after the repair area has been cleaned of all materials, including all rust, such that the base metal areas can be visually examined and allow the use of an ultrasonic thickness gauge. After inspection, the Engineer may adjust the repair limits as conditions warrant.

**MATERIALS**

All new structural steel and new high strength bolts shall conform to the requirements of Sections M8.05.0 and M8.04.3 of the Standard Specifications, respectively.

All structural steel shall be AASHTO M270, Grade 36 or Grade 50 steel.

The repair steel shall be considered main member and conform to the Charpy V - notch impact test requirements for AASHTO Temperature Zone T2.

All high strength bolts for bolted connections shall be slip critical and conform to the requirements of AASHTO M164 (ASTM A325) and installed in accordance with the Standard Specifications. All proposed nuts shall conform to AASHTO M291. Washers shall conform to AASHTO M293 specifications for hardened steel washers. All bolts, nuts and washers shall be mechanically galvanized in accordance with requirements of AASHTO M298, Class 50. Galvanized bolts shall be retested after galvanizing as required by AASHTO M164.

Prior to installing steel repair components, an epoxy-based metal filler compound shall be applied to existing deteriorated steel web surfaces and flanges in a manner which restores deteriorated sections to their original thicknesses to prevent voids between the filler surface and proposed repair plates. Filler material shall be applied as shown in the plans and as required by the Engineer. Epoxy filler compound shall be "ITW Philadelphia Resin Repair Compound (RRC)" (web site: <http://chockfast.com/products/repair-and-accessory-products/itw-repair-compound/>), or Sikadur 31, Hi-Mod Gel (web site: <http://usa.sika.com>), or Adhesives Technology Ultrabond 2100, Class C (web site: <http://atcepoxy.com/medium-viscosity-bonding-agent-ultrabond-2100/>), or an approved equal. The filler compound shall be applied in strict accordance with the manufacturer's specifications.

The Contractor shall apply silicone caulking at all locations where the existing steel and the proposed steel meet after the top coat of paint has fully cured. Silicone caulking shall be recommended, applied, and be compatible with the paint system manufacturers requirements. At locations where the gap between the existing steel and proposed steel is 1/8" or greater, the silicone caulk shall be tooled into gaps. The silicone caulk and its installation shall be considered incidental to this Item.

The Contractor is alerted that the existing paint maybe lead-based. Any removal and disposal of paint for the operations described herein shall be performed in strict conformance with all State and Federal health and environmental regulations, as stipulated in these specifications.



**ITEM 107.97** (Continued)**CONSTRUCTION METHODS**

All work shall be done as accepted by the Engineer in accordance with the details approved by the Engineer.

The Contractor shall submit for review an engineering submittal for each repair location. The submittal shall include, but is not limited to, a repair procedure and drawings detailing the repairs. The engineering submittal shall bear the seal and signature of a Professional Engineer of the appropriate discipline registered in Massachusetts. The methods of procedures, materials, equipment, or anchorage proposed by the Contractor shall be submitted on a standard shop drawing for approval by the Engineer prior to beginning of work for each location. Approval shall not relieve the Contractor of responsibility for the successful completion of the work.

All steel repair dimensions shall be field verified by the Contractor prior to developing shop drawings and fabrication of steel repair components. The limits of steel repairs shall be verified via Non-destructive testing (PT, MT, UT) at locations as required by the Engineer. Testing shall be performed by a certified testing agency and shall meet the requirements of Subsection 960.61, Inspection paragraphs of the Standard Specifications. The cost associated with the Non-destructive testing will be compensated under the T&M provisions of this Contract. The Contractor shall submit shop drawings using field measurements. The Engineer will verify the proposed repair limits shown on the shop drawings. Fabrication of repair components shall not start prior to acceptance of shop drawings by the Engineer.

All steel superstructure members shall be cleaned to meet the requirements of SSPC SP-10, Near-White Blast Cleaning and receive a prime coat prior to beginning steel repairs, in accordance with Subsection 961, "Maintenance Painting of Steel Bridges". The Engineer shall verify the deterioration extents prior to fabrication of repair components. Subsequent to successful steel repairs at each span and primer touch up of repair areas the superstructure steel shall be painted with the intermediate and final coats. All costs of cleaning and painting shall be paid for under Item 961.211.

**Welding**

All welding shall conform to the latest edition of the Bridge Welding Code AASHTO/AWS D1.5 and shall meet the following requirements unless specified otherwise:

All welding required to complete the repairs will be considered as incidental to the repair and no separate compensation will be allowed. All welders shall be certified. Welders' qualifications certificates must be submitted to the Engineer for approval. Electroslag and electro gas welding will not be permitted. Welding will not be permitted when the air temperature is below 35 F or when the surfaces to be welded are wet from condensation, rain, snow or ice. When the temperature is between 35 F and 45 F, the surface within 3" of the point where the weld is to be started shall be heated to a temperature of approximately 100 F, and this temperature shall be maintained as a minimum within this distance until the bead is completed.

**ITEM 107.97** (Continued)

The Contractor shall submit for approval by the Engineer a welding procedure for each of the repair areas that will require welding.

**Inspection and Non-Destructive Weld Testing**

All welds are to be inspected and tested (non-destructively) in accordance with AASHTO/AWS D1.5M/D1.5 and the applicable provisions of the Standard Specifications Subsection 960, and the specifications stipulated in these special provisions.

Inspection shall consist of checking the type, location, size, length, returns and profile of field welds and shop welds. Welds will be evaluated by their surface appearance, completeness for penetration and fusion, avoidance of undercutting, freedom from slag, inclusions, porosity, cracks and general appearance.

All welds that are found to be defective shall be corrected in accordance with the AWS procedures and to the approval of the Engineer and shall then be re-inspected as outlined above. The expense of such corrective work shall be borne by the Contractor.

The Contractor shall be responsible for Quality Control Inspection and Non-Destructive Weld Testing of all shop welding and field welding of non-fracture-critical members in accordance with the requirements here specified. These costs shall be considered incidental to the various steel repair pay Items.

**Cutting of Steel**

Existing steel components that are required for replacement by the Engineer shall be carefully removed by dismantling existing connections and by machine cutting. Cutting of existing steel shall be performed with care to avoid undercutting, overheating, notching or other damage of material which is to remain. The Contractor shall use temperature-indicating crayons which meet the approval of the Engineer for 275 degrees Fahrenheit and 300 degrees Fahrenheit. These indicator crayons shall be used on surfaces of the web and beam adjacent to the area being cut or ground as ordered by the Engineer.

Cutting or grinding shall be discontinued temporarily, to allow cooling, if the temperature of the base steel in the girder web or flange exceeds 275 degrees Fahrenheit.

If the Contractor damages materials to remain during cutting operations, he shall replace, repair, or reinforce the damaged area as may be needed to restore the damage to existing condition prior to damage. This work shall be performed by the Contractor as required and approved by the Engineer at no additional cost to MassDOT.

---

**ITEM 107.97** (Continued)**Environmental**

All applicable portions of Subsections 961.65 "Worker Protection" and 961.66 "Environmental Protection and Monitoring" shall be followed when performing this work.

During chemical stripping, a hand washing facility may be used in lieu of a decontamination/changing facility. Hazardous material shall be collected during the disassembly and disposed of as outlined in Subsection 961.68 "Handling of Hazardous Waste and Reporting Release Programs". Submittals shall be according to Subsection 961.69 "Submittals".

**Additional Requirements**

The edges of the existing steel to be repaired, as well as the faces that will meet the new steel, shall be ground smooth and primed prior to the installation of the new plates or shapes. Holes in steel shall be drilled, not punched or burned. Rust holes +/- 3" in diameters shall be drilled prior to installation of repair plates. Isolated rust holes in the girder web panel shall be drilled or coped to a consistent web thickness of 1/8". Edges of the holes or copes are to be ground smooth to the approval of the Engineer.

The Contractor is responsible for the accuracy and fit of the work and thus shall determine what measurements are required and shall allow adequate time and resources for obtaining field measurements in developing his fabrication and construction.

The Contractor shall submit shop drawings utilizing the field measurements of the replacement/repair areas to confirm bridge components and all other repair dimensions. Fabrication shall not start prior to acceptance of shop drawings.

The Contractor shall provide support for interim and final inspection of the bridge during cleaning operations. This support shall include the necessary traffic controls (if required) and safe access to the work.

When it is necessary to temporarily support utility lines/pipes during steel repairs, the Contractor shall consult with the affected utility owners on the proposed Means and Methods of this work item. Any damage to the utilities caused by the Contractor's operations shall be repaired by the Contractor to the approval of the Engineer and the affected utilities, at the Contractor's own expense.

Adequate measures shall be taken by the Contractor to prevent work generated debris, tools, and/or materials from entering adjacent roadway lanes or dropping to the ground or waterway below the structure. All debris and any materials which, accidentally fall into such areas shall be removed immediately at the Contractor's expense. Any damage from falling debris shall be repaired by the Contractor to the approval of the Engineer at the Contractor's own expense.

Except as otherwise specified, all removed steel and appurtenances shall become the property of the Contractor who shall remove and dispose of this material.

**ITEM 107.97** (Continued)

The Contractor shall take the necessary precautions such as flaggers, warning signs and/or temporary protective structures for the safety of vehicles or pedestrians using any area adjacent to or under the work areas. Any such structure shall be adequate for the purpose and shall be approved by the Engineer.

**METHOD OF MEASUREMENT**

Item 107.97 will be measured for payment by the Pound of new structural steel (including bolts for steel repairs) installed, complete in place, and accepted by the Engineer.

**BASIS OF PAYMENT**

Item 107.97 will be paid for at the Contract unit price per Pound, which price shall include all engineering services, materials, labor, submittal preparation, equipment, scaffolding, welding, tools, field inspection, utility support, nuts, bolts heads and permanent washers, furnishing, transporting and erecting structural steel for repairs, and all other incidental costs required to complete the work.

The weight of bolts, nuts, washers and welding material is incidental to the steel and is not included in the calculated weight for payment.

**ITEM 127.1****REINFORCED CONCRETE EXCAVATION****CUBIC YARD**

The work under this Item shall conform to the relevant provisions of Subsections 120 and 482 of the Standard Specifications and the following:

The work shall consist of the removal and disposal of all disintegrated or otherwise unsatisfactory reinforced concrete, as required by the Engineer.

**Note:** Some of the bridges, due to their height (vertical clearance), will require special lifting equipment to place shielding for the assigned bridge repair work. Any equipment required to erect forms will be incidental to this item.

Prior to excavation, the Contractor shall cover all drainage structures that may be affected by the work. The structures shall remain covered until the new concrete has set and the area has been cleaned.

The Contractor shall take all precautions necessary not to damage that portion of the structure, including reinforcing steel, which is to remain. This includes determining the concrete cover to the steel bars at the edge of each patch prior to excavating concrete.

The edges of all areas where concrete is removed under Item 127.1 shall be cut to neat lines by saw cutting or by methods approved by the Engineer, to a depth of 1 inch, and all costs in connection with such work shall be incidental to this item. Patch areas shall be made rectangular in shape [as much as possible], with horizontal and vertical edges and square corners.

In case the reinforcing bars are exposed, the minimum depth of all cement concrete areas to be excavated shall be one (1) inch below the bottom of the top layer of longitudinal reinforcing steel throughout the entire excavated area. No concrete shall be placed until approval of the Engineer is given.

Surface preparation and concrete removal equipment shall be of the following types:

**Pneumatic and Power-Driven Chipping Hammers:** In no event shall any pneumatic or power hammer weighing in excess of twenty-five (25) pounds be used for the removal of concrete. The Contractor will be restricted to fifteen (15) pound chipping hammers when work involves repairs to slabs of prestressed concrete adjacent deck or box beams, or when removing concrete from below any reinforcing bar.

**Abrasive Blasting Equipment:** Abrasive blasting equipment shall be capable of removing rust and old concrete from exposed reinforcing steel when required by the Engineer.

During the prosecution of this work, the Engineer may reject the use of any method or equipment which causes undue vibration or possible damage to the structure or any part thereof.

Bobcats/Skid Steers will be allowed only to collect debris from the deck surface and will not be allowed to remove concrete from the patch area. All concrete debris shall be removed by hand or by using hand tools. The smaller pieces may be blown out using an oil free compressed air after first being wetted with water to control airborne particulates.

**ITEM 127.1** (Continued)

Also, included under this Item are all costs in connection with the cleaning, cutting, and bending of the existing reinforcing steel designated to be retained in the proposed construction. Any existing reinforcing steel damaged or otherwise made unsatisfactory for continued use as a result of the Contractor's operations shall be replaced at the Contractor's expense. All reinforcing steel with active rusting encountered in the excavation shall be thoroughly cleaned by abrasive blasting and coated with a zinc-rich primer conforming to MassDOT Spec. No. M7.04.11 or as required by the Engineer. Any reinforcing steel that is unsuitable for further use through no fault of the Contractor shall be replaced under Item 910.1. All reinforcing steel that is loose shall be tied tightly together using wire ties. Ties are required at every other intersection of transverse and longitudinal reinforcing.

Temporary Protective Shielding must be used on bridges over the roadway, railroad, or waterway during full depth excavation and when, in the opinion of the Engineer, there is the possibility of dislodging concrete from the bottom of the deck.

The Contractor shall take all measures necessary to protect pedestrian, vehicular traffic, waterway, or railroad below from the construction operations. No debris, tools or incidental equipment of any kind will be permitted to fall into areas where vehicular or pedestrian traffic exists. Any material that accidentally falls into such areas shall be removed immediately.

All excavated materials shall become the property of the Contractor and shall be removed from the job site.

**METHOD OF MEASUREMENT**

Item 127.1 shall be measured for payment by the Cubic Yard of reinforced concrete excavated, removed and disposed of.

**BASIS OF PAYMENT**

Item 127.1 will be paid at the Contract unit price per Cubic Yard. The quantity paid for this Item shall be the actual volume excavated to be removed and properly disposed according to all city, town, State and Federal rules, regulations, and requirements and as required by the Engineer. The Contract unit price shall include all labor, tools and equipment, sawcutting, and all incidental costs required to complete the work.

New reinforcing steel will be paid under Item 910.1

Payment for temporary protective shielding shall be made under Item 994.1.

**ITEM 748.1**

**EMERGENCY RESPONSE**

**EACH**

The work under this Item shall conform to the relevant provisions of Subsection 748 of the Standard Specifications and the following:

This Item shall consist of preparatory work and operations for emergency response after notification from the Engineer. It shall include preparations necessary for the movement of personnel, equipment, and incidentals to the project site for the establishment of an effective response under the work assignment.

**Note:** The Contractor is required to commence emergency work within (4) four hours of notification.

**METHOD OF MEASUREMENT**

Item 748.1 will be measured for payment by the Each notified emergency Work Order when the Contractor commences work within (4) four hours of notification.

In the event that another emergency occurs during the period that the Contractor's forces have been notified and are mobilizing or working, all additional responses performed by a different emergency response crew at a different work site during that period will be considered an additional emergency response in accordance to the requirements specified herein.

The Engineer will determine if conditions required another crew to be mobilized as a separate emergency response.

The Emergency Response item is not applicable if the emergency occurs during scheduled working hours.

**BASIS OF PAYMENT**

Item 748.1 will be paid for at the Contract unit price per Each, which price shall be full compensation for all costs associated with ensuring prompt response to emergency situations and to get equipment to a deemed emergency location in time.

In the event that the Contractor does not satisfy the (4) four hours response time, payment for Emergency Response will be made only at the discretion of the Engineer.

A non-response damages will be assessed in the amount specified under NON-RESPONSE DAMAGES for each assignment the Contractor fails to report as required.

All labor, material and equipment to perform the emergency work will be paid for under the appropriate pay items.

**ITEM 853.8**

**TEMPORARY ILLUMINATION FOR WORK ZONE**

**DAY**

The work under this Item shall conform to the relevant provisions of Subsection 850 of the Standard Specification and the following:

The work under this Item shall include the deployment and maintaining in proper operating condition a LED balloon diffuser lighting system. These portable light towers shall be used throughout the project area for temporary work zone lighting. The use of unshielded high wattage flood lights shall not be permitted.

These towers shall be used, relocated and adjusted to meet the criteria in Subsection 850 of the Standard Specifications and the following:

The Contractor shall illuminate the following work zone areas:

- Change in direction (i.e., work zone entrances and exits, crossovers, etc.)
- Tapered areas
- Actual area where the construction is being performed

Light measurement shall be based on the illuminance method and the lighting levels shall be based on the classification of construction activity that is taking place. At no time shall the light level be below 5 fc and the uniformity shall not exceed 6:1. Task Classifications and recommended illumination levels is shown in Table 1.



**ITEM 853.8** (Continued)

<b>Task Classifications</b>	<b>Illumination Level</b>	<b>Average Minimum Maintained Illuminance</b>
All work operations areas, setup of lane or road closures, lane closure tapers, and flagging stations, such as: Excavation (all types), Embankment Fill and Compaction, Reworking Shoulders, Asphalt Pavement Rolling, Subgrade, Stabilization and Construction, Base Course Rolling, Sweeping, Cleaning and Landscaping.	Level I	5 foot-candles
Areas on or around construction equipment; asphalt paving, milling, and concrete placement and/or removal, such as, Milling, Removal of Pavement, Asphalt Paving and Resurfacing, Concrete Pavement, Waterproofing and Sealing, Sidewalk Construction, Base Course Grading and Shaping, Surface Treatment, Bridge Decks, Drainage Structures and Drainage Piping, Other Concrete Structures, Barrier Wall and Traffic Separators, Guardrails and Fencing, Striping and Pavement Markings, Repair of Concrete Pavement, Highway Signs, Hole Filling and Repair of Guardrails and Fencing.	Level II	10 foot-candles
Pavement or structural crack/ pothole filling; joint repair, pavement patching and/or repairs, installation of signal/electrical/mechanical equipment, such as, Traffic Signals, Highway Lighting Systems and Crack Filling	Level III	20 foot-candles

TABLE 1  
TASK CLASSIFICATIONS AND ILLUMINATION LEVELS

Prior to commencement of work the Contractor shall submit to MassDOT for approval a description of illumination equipment that is proposed to be used on this project, and shall include photometrics that detail the light levels that are to be provided for the particular operation for the type of equipment, level of luminance and height to be installed.

Any potential glare from the lighting system should be considered from each direction and on all approaching roadways and opposing lanes of traffic. Glare from the illumination system should be minimized as much as possible for both workers and motorists in adjacent active travel lanes.

If necessary, the Contractor shall provide supplemental hardware, such as, visors, louvers, shields, glare screen and barrier to reduce glare in adjacent active travel lanes.

Equipment mounted lighting may be used to supplement light towers to achieve the required lighting levels for the activity involved per Table 1.

**ITEM 853.8** (Continued)

**METHOD OF MEASUREMENT**

Item 853.8 will be measured for payment according to Subsection 850.80 of the Standard Specifications.

**BASIS OF PAYMENT**

Item 853.8 will be paid for according to Subsection 850.81 of the Standard Specifications.

**ITEM 854.6****TEMPORARY PORTABLE RUMBLE STRIP****DAY**

The work under this Item shall conform the relevant provisions of Subsection 850 of the Standard Specifications and the following:

The work under this item consists of furnishing, deploying, maintaining in proper operating conditions, and removing temporary portable rumble strips (TPRS) for temporary lane closures of 24 hours or less.

**MATERIALS**

The TPRS shall be 10' to 11' wide, measured perpendicular to the path of travel, 12" to 16" long, measured parallel to the path of travel, and 0.5" to 0.75" tall. All edges shall be beveled. The surfaces shall be grooved to limit potential hydroplaning.

The TPRS shall lay flat on the road surface without the use of nails, anchors, or adhesives, and shall be flexible so as to conform to the surface profile.

The TPRS shall be able to withstand vehicle weights of up to 80,000 lbs. and operate in temperatures between 0° to 120° F.

The manufacturer shall certify the TPRS to be safe for use on roads with speed limits of at least 70 mph.

TPRS that appear damaged or functioning in an unsafe manner may be ordered removed by the Engineer and replaced at no additional cost.

**CONSTRUCTION METHODS**

The TPRS shall be installed per the plans or at the discretion of the Engineer.

The Contractor shall conform to the manufacturer's specifications for installation and the following:

- A. The road surface shall be cleared of all gravel, sand, and debris.
- B. If RoadQuake 2™ model is used, the modular pieces shall be assembled into 11-foot strips per the manufacturer's instructions in advance of deployment. The interconnected segments shall form a smooth and flat, continuous section.
- C. A Truck-Mounted Attenuator, conforming to Subsection 850, shall be used as shadow vehicle protection during the deployment and removal of TPRS on any roadway with speeds of 45 mph or greater.
- D. TPRS shall be deployed in conjunction with all other temporary traffic control devices. MA-W28-1 (Rumble Strips Ahead) sign(s) shall be installed per the Temporary Traffic Control Plan.

**ITEM 854.6** (Continued)

## E. TPRS deployment:

1. TPRS shall be placed perpendicular to the direction of travel, centered in the lane.
2. Three (3) individual strips are required for a single array.
3. Refer to the Temporary Traffic Control Plan for the location of the array respective to the lane closure.
4. The spacing of the individual strips within the array shall conform to the following table:

<b>Speed Limit</b>	<b>Distance Between Rumble Strips (measured center-to-center)</b>
>55 mph	20 feet
40 mph to 55 mph	15 feet
<40 mph	10 feet

5. The TPRS shall be placed without the use of nails, adhesives, or other methods of affixing them to the road surface.
- F. All TPRS shall be maintained in proper condition, alignment, spacing, and location throughout the duration of the lane closure, at no additional cost.
- G. The TPRS shall be removed prior to the removal of the traffic control devices used to close the travel lane.
- H. TPRS shall not be used during snow events.

**METHOD OF MEASUREMENT**

Item 854.6 will be measured by the Day which shall include an array of three (3) temporary portable rumble strips. Each period of up to 24 hours during which this unit is in use will be measured as one day regardless of the number of times the array is deployed, repositioned, or removed.

**BASIS OF PAYMENT**

Item 854.6 will be paid for at the Contract unit price per Day, which shall include full compensation for furnishing, deploying, repositioning, and removing the array of three (3) individual strips as required by the Engineer.

---

**ITEM 859.1**      **REFLECTORIZED DRUMS WITH SEQUENTIAL**      **DAY**  
**FLASHING WARNING LIGHTS**

The work under this Item shall conform the relevant provisions of Subsection 850 of the Standard Specifications and the following:

The work under this Item consists of furnishing, installing, maintaining in proper operating conditions, and removing reflectorized drums, and any necessary ballast, equipped with sequential flashing warning lights.

**MATERIALS**

Reflectorized drums shall be listed on the MassDOT Qualified Traffic Control Equipment List. Reflective sheeting on drums shall meet or exceed ASTM D4956 Type VIII. All drums shall be maintained in a satisfactory manner including the removal of oils, dirt, and debris that may cause reduced retroreflectivity.

The Contractor shall use one of the following sequential flashing warning light systems unless otherwise approved by the Engineer:

1. Empco-Lite LWCS.
2. pi-Lit® Sequential Barricade-Style Lamp; or
3. Unipart Dorman SynchroGUIDE.

Sequential flashing warning lights shall be secured to reflectorized drums per the light manufacturer's specifications.

**CONSTRUCTION METHODS**

The first ten (10) drums in any merging or shifting taper as designated in the Temporary Traffic Control Plan shall be equipped with sequential flashing warning lights. These lights shall be operating, at a minimum, between dusk and dawn when the taper is deployed.

The successive flashing of the sequential warning lights shall occur from the upstream end of the merging or shifting taper to the downstream end of the taper in order to identify the desired vehicle path. Each warning light in the sequence shall be flashed at a rate of not less than 55, nor more than 75 times per minute.

Warning lights shall be powered off when drums are not deployed in a taper.

**METHOD OF MEASUREMENT**

Item 859.1 will be measured per day with a group of ten (10) reflectorized drums with sequential flashing warning lights considered one (1) unit. Each period of up to 24 hours during which this unit is in use will be measured as one day regardless of the number of times that the drums are positioned, repositioned, removed, or returned to service.

**BASIS OF PAYMENT**

Item 859.1 will be paid for at the Contract unit price per Day, which shall include full compensation for furnishing, positioning, repositioning, and removing the group of ten (10) drums as required by the Engineer.

---

<b><u>ITEM 866.206</u></b>	<b><u>6 INCH REFLECTORIZED WHITE LINE (POLYUREA) (RECESSED)</u></b>	<b><u>FOOT</u></b>
<b><u>ITEM 867.206</u></b>	<b><u>6 INCH REFLECTORIZED YELLOW LINE (POLYUREA) (RECESSED)</u></b>	<b><u>FOOT</u></b>

Work to be completed under these items shall conform to the relevant provisions of Subsection 860 of the Standard Specifications and the following:

Work shall consist of grooving a slot in the pavement surface and the furnishing and installation of wet reflective polyurea pavement markings.

Work under these items shall consist of the furnishing and installation of white and lead-free yellow polyurea reflectorized pavement markings (including edge lines, skip lines, gore lines, and arrows and legends) on all new pavement surfaces.

Installation of permanent pavement markings must begin within 14 days of the start of the placement of the top course and must be completed within 14 days of the completion of the top course.

As work incidental to these items the Contractor or polyurea Material Supplier shall measure the performance of the pavement markings upon installation after seven days of installation.,

### **MATERIALS**

Wet reflective polyurea pavement markings shall consist of a liquid binder, first drop beads or elements to provide dry and wet retroreflectivity, and second drop glass beads to improve the durability of the pavement marking, reduce track-free times, and provide supplementary dry retroreflectivity.

The Contractor shall use one of the following binders and first drop beads or elements, or approved equivalents:

1. 3M™ Liquid Pavement Marking Series 5000 with 3M™ All Weather Series 90 elements;
2. Epoplex GLOMARC® 90 with Potters VISIMAX® Glass Bead System; or
3. SWARCO MFUA-12 with SWARCO MEGALUX-BEADS®.

Combination of other binder and first drop bead or element series may only be used at the approval of the Engineer.

Second drop beads shall be manufactured from glass of a composition that is highly resistant to traffic wear and to the effects of weathering. If coating is required to meet the performance requirements, the second drop beads shall be coated to ensure satisfactory embedment and adhesion. Second drop beads retained on a No. 40 U.S. Standard Mesh Sieve shall have a minimum crush strength of 30 lbs. when tested in accordance with ASTM D1213.

Second drop beads shall have a minimum refractive index of 1.51 when tested in accordance with AASHTO M247.

**ITEM 866.206 and 867.206** (Continued)

Second drop beads passing the No. 30 sieve shall have a minimum of 75 percent true spheres when tested in accordance with ASTM D1155. All second drop beads retained on the No. 20 and No. 30 sieves shall have a minimum of 80 percent true spheres as determined by ASTM D1155. Second drop beads shall meet the following gradation requirements when tested in accordance with ASTM D1214:

U.S. Standard Sieve No.	Percent Retained
20	3-10
30	15-35
50	45-75
70	0-10
Pan	0-5

**CONSTRUCTION METHODS****Installation of Groove**

Prior to cutting out the grooves for all recessed lines, the Contractor shall use a chalk line or other suitable method to layout the proposed pavement markings on the surface course so that the Engineer can inspect the locations. Once the Engineer has inspected and approved the proposed striping layout, the grooves for the proposed pavement markings may be cut. No pavement grooving shall be done without the prior approval of the Engineer.

Groove position shall be a minimum of 4 inches from the edge of the pavement marking to any longitudinal pavement joints. The groove shall not be installed on bridge joints, on drainage structures, or in other areas identified by the Engineer. **NOTE WELL: The groove shall not be installed continuously for intermittent pavement markings, but only where markings are to be applied.**

The use of gang stacked diamond cutting blades to grind a smooth square slot is required for producing all grooves. The spacers between blade cuts shall be such that there will be less than a 10 mil rise in the finished groove between the blades. The acceptability of the surface texture will be determined by the Engineer.

The diamond grinder shall have an articulating head so that the slots are installed correctly on grades and super elevated sections.

Grooves that are ground deeper or wider than the specified allowable limits shall be repaired per the direction of the Engineer at no additional cost. Grooves that are ground too shallow, too narrow, or with unacceptable rises between blade cuts shall be reground to the correct size, depth, and surface finish at no additional cost. Slots ground out of alignment shall be patched using an approved method and materials.

**ITEM 866.206 and 867.206** (Continued)

Grooves shall be 1 inch  $\pm$  ¼ inch wider than the pavement marking material. Groove depth shall be 100 mils  $\pm$  5 mils, unless otherwise approved by the Engineer. Depth shall be consistent across the full width of the groove. Depth plates shall be provided by the Contractor to the Engineer to assure that desired groove depth is achieved.

Grooves shall be clean, dry and free of laitance, oil, dirt, grease, paint or other foreign contaminants. Shrouds and a vacuum apparatus shall be included as part of the grinder to remove larger pieces of pavement that are ground out. If water is used to clean the groove or the grooving process takes place during rainfall, a minimum of 24 hours of dry time is required prior to the placement of pavement markings.

After the depth, width, length, and surface condition has been approved by the Engineer, an air lance shall be used to remove fine particles from the groove. Air compressors shall initially be blown out away from the application area to prevent compressor condensation build-up from entering the groove. The Contractor shall prevent traffic from traversing the grooves and re-clean grooves, as necessary, prior to application of pavement markings at no additional cost to the Department.

All grooves must be given final approval by the Engineer prior to the placement of pavement markings.

**Installation of Wet Reflective Polyurea**

Installation of wet reflective polyurea pavement markings shall conform to the Manufacturer's specifications and the following:

Application rate for binder and all beads and elements shall consider final pavement surface composition and smoothness in advance of application to ensure proper wet film thickness and embedment of all beads and elements. The Contractor shall provide the Engineer with documentation from the Manufacturer with all recommended application rates (and conformance to initial dry and wet reflectivity requirements) in advance of any pavement marking installation.

The minimum uniform wet thickness for the polyurea binder shall be 25-30 mils. The line thickness shall be met across at least the middle ⅔ of the pavement marking width. Depth plates shall be provided by the Contractor to the Engineer to assure that desired thickness is achieved.

The finished white color shall be free from tint, with good opacity and visibility under both daylight and artificial light. The finished yellow color shall be defined by Federal Test Standard 595 - Color Chip Number 13538, using Federal Test Standard 141 (Method 4252). The finished lines shall be uniform in color and have clean, well-defined edges.

First and second drop beads and/or elements shall be applied in a manner that does not induce rolling or bouncing, to ensure that exposed portions of beads are free of binder material. Beads and elements should be embedded in the binder to a depth of approximately 50% of their diameter.



### **ITEM 866.206 and 867.206** (Continued)

Drop rate for first drop bead or element shall be per the Manufacturer's specifications.

Drop rate for second drop glass bead shall be 6.4-10.2 lbs. per gallon.

Newly installed pavement markings shall be protected from tracking during the setting period per Subsection 860.63.

Incidental to the cost of these items, the Contractor shall measure the average retroreflectance of the pavement markings and report the results to the Engineer. The Contractor shall take retroreflectance measurements between 7 and 14 days from date of application. Contractor shall perform retroreflectance readings per the measurement and sampling procedures contained in ASTM D7585 (Standard Practice for Evaluating Retroreflective Pavement Markings Using Portable Hand-Operated Instruments) using the Referee Evaluation Protocol found in section 6.4.

The following tests shall be performed during the measurement and sampling process:

1. ASTM E1710 (*Standard Test Method for Measurement of Retroreflective Pavement Marking Materials with CEN-Prescribed Geometry Using a Portable Retroreflectometer*); and
2. ASTM E2177 (*Standard Test Method for Measuring the Coefficient of Retroreflected Luminance (RL) of Pavement Markings in a Standard Condition of Wetness*).

The average initial retroreflectance readings shall exceed the following minimum values:

	*White Markings	*Yellow Markings
ASTM E1710 (Dry)	475 mcd/lux/m <sup>2</sup>	375 mcd/lux/m <sup>2</sup>
ASTM E2177 (Wet Recovery)	375 mcd/lux/m <sup>2</sup>	300 mcd/lux/m <sup>2</sup>

\*Observation Angle = 1.05°, Entrance Angle = 88.8°

Pavement markings with measured average initial retroreflectance readings that do not meet the specified minimum values using the procedures outlined in subsection 6.4.5 of ASTM D7585 shall be removed by a method approved by the Engineer and reapplied at no additional cost.

### **MARKING PERFORMANCE**

Upon completion of the pavement marking installation, the following data shall be tabulated by the Contractor:

1. Retroreflectance readings, including date(s), time(s), and location(s) where readings took place;
2. Liquid binder type(s) and application rate;
3. Reflective element type and drop rate;
4. Date of groove installation;
5. Lot, batch number, or any other material identifiers and manufacturing information;
6. Date and time of final liquid marking installation;
7. Highway location (including direction) of installation;
8. Air and pavement temperature during application;
9. Measured material application thickness, depth of groove; and
10. Any other pertinent information that may assist MassDOT with Quality Control.

**ITEM 866.206 and 867.206** (Continued)

**METHOD OF MEASUREMENT**

Items 866.206 and 867.206 will be measured respectively according to Subsection 860.80 of the Standard Specifications.

**BASIS OF PAYMENT**

Items 866.206 and 867.206 will be paid for respectively according to Subsection 860.81 of the Standard Specifications.

---

**ITEM 905.                    4000 PSI, 3/8 INCH, 660 CEMENT CONCRETE                    CUBIC YARD**

Work under this Item shall conform to the provisions of Subsection 901 of the Standard Specifications and the following:

The work under this Item shall consist of furnishing and placing 4000 PSI, 3/8 INCH, 660 Cement Concrete. This item shall be used for patching after all deteriorated and/or unsound concrete is removed under Item 127.1.

All formwork shall be approved and accepted by the Engineer prior concrete placement.

All formwork placed under this item must be removed no later than forty-five (45) days after the repair has been completed. Failure to remove said formwork within said forty-five (45) days could result in its removal by others with the associated costs being assessed to the Contractor.

**PREPARATION OF CONCRETE SURFACE**

All concrete surfaces to be patched shall be roughened, cleaned of all laitance, dirt, grease, oil, other contaminants and all standing water. All reinforcing steel encountered in the excavation shall be thoroughly cleaned by abrasive blasting and coated with a zinc-rich primer conforming to MassDOT Standard Specification M7.04.11 before being covered with new concrete.

The excavated areas shall then be coated with and Epoxy Bonding Compound. At the discretion of the Engineer, epoxy bonding compound may be omitted in favor of a thorough application of water for a minimum of 10 minutes, any remaining water should be blown out to produce a saturated surface dry (SSD) condition, using oil free compressed air.

**METHOD OF MEASUREMENT**

Item 905. will be measured for payment by the Cubic Yard, of cement concrete actually furnished and installed complete in place.

**BASIS OF PAYMENT**

Item 905. will be paid for at the Contract unit price per Cubic Yard, which price shall include all labor, materials, equipment, surface preparation, oversight services, and all incidental costs required to complete the work.

No separate payment will be made for the installation and subsequent removal of any formwork, coating/patching of the steel reinforcing, but all costs in connection therewith shall be included in the Contract unit price bid. The use of Epoxy Bonding Compound when required by the Engineer, shall be incidental to this Item.

Where formwork is installed for concrete placement, payment of seventy percent (70%) of the Cubic Yard price of this item will be made upon complete concrete installation.

The remaining thirty percent (30%) of the Cubic Yard price of this Item will be paid only after complete formwork removed by the Contractor.

**ITEM 910.1**

**STEEL REINFORCEMENT FOR  
STRUCTURES – EPOXY COATED**

**POUND**

The work under this Item shall conform to the relevant provisions of Subsection 901 of the Standard Specifications and the following:

All requirements of Subsection 901.62 Reinforcement shall be adhered to, including but not limited to lapping at splices and ties at every other intersection.

The Contractor may be required to submit for approval, detail plans and schedule of bar reinforcement. The Contractor will replace reinforcing bars as required by the Engineer. Any reinforcing steel damaged by the Contractor's operations will be replaced by the Contractor at their own expense.

Steel reinforcement lapped splices shall only be permitted with the approval of the Engineer, provided the extent of the distressed concrete removed to the limits as approved by the Engineer allows for obtaining required lap lengths.

The Contractor may be required to use standard non-epoxy coated (black bar) instead of epoxy coated bar as required by the Engineer.

**METHOD OF MEASUREMENT**

Item 910.1 will be measured for payment according to Subsection 901.80 of the Standard Specifications.

**BASIS OF PAYMENT**

Item 910.1 will be paid according to Subsection 901.81 of the Standard Specifications.

The use of non-epoxy coated black bar will be substituted with no additional compensation, as required by the Engineer.

**ITEM 961.211****CLEAN (FULL REMOVAL) AND  
PAINT – STRUCTURAL STEEL****SQUARE FOOT**

The work under this item shall conform to the relevant provisions of the Standard Specification, Subsection 960 and 961 and the following:

The work under this item includes the surface preparation and painting of all designated steel areas, including but not limited to the beams, cross frames, utility supports, bearings, and railing. This item also includes environmental protection, containment of work areas, waste disposal and a work barge, if the Contractor chooses this as a staging area.

This work shall be for the cleaning and painting of bridge railing and structural steel in areas where repairs or corrosion arresting measures are required. The Engineer and Contractor shall agree on a square foot area to be paid before work starts for complex areas. It is expected multiple mobilizations will be required for each location. Locations where steel repairs are to be done shall be cleaned and primed prior to steel repairs. After steel repairs have been completed, the areas shall have Intermediate and final coats of paint applied. Painting work will be required at multiple locations.

**DESCRIPTION**

Work included under this Item consists of cleaning (full removal) and painting all painted structural steel elements within the limits described above.

Full Removal - in designated areas to the limits as specified by the Engineer to 6 inches outside of the designated repair area.

After structural steel repairs have been completed, the entire repair area including previously cleaned exposed steel surfaces, new repair plates and additional steel shall be abraded. Cleaning and preparing new bolts and nuts used in the installation of structural steel repairs shall also be considered incidental.

**PAINT**

All steel surfaces within the limits shall receive three full coats of paint (primer, intermediate, and finish) to be color, chemical and adherent compatible with the paint to be over-coated.

The Contractor shall over-coat by six (6) inches the previously painted areas with the final coat of the three-coat system. However, the over-coated surfaces must be surface prepared in accordance with the manufacturer's specifications to ensure a proper bond of the new paint to the existing paint.

The Contractor should note that some steel repairs made under previous contracts may have been painted with the XV MAX three coat paint system or other previously approved paint systems and shall be properly abraded to assure a proper bond. There may also be some repairs made with just shop primer on them, these areas are also to be abraded as required to assure a proper bond. Incidental to this Item will be the cleaning and removal of any accumulated materials in the areas to be cleaned and painted.

**ITEM 961.211** (Continued)

The Contractor shall remove and dispose of the pigeon waste and any other debris accumulated on the steel members and bridge seats in areas where work is being performed. Pigeon waste and debris material contaminates will require special handling and disposal in accordance with all Federal, State, and Local requirements.

The Contractor shall clean all exposed surfaces of abutment seats and pier caps by power washing to the approval of the Engineer. All costs of cleaning abutment seats and pier caps including debris collection & removal, disposal and pressure washing shall be considered incidental to this Item.

Failure of the Contractor to provide the required submittals under Subsection 961, Subsection 961.69 "Submittals", within 30 days from the date each specific Work Order is issued, which includes Item 961.211, shall be determined to be Non-Responsive and subject to Non-Response Damages as described in the Contract.

**STRUCTURAL STEEL INSPECTION**

The Contractor shall notify the Engineer if significant amount of section loss is found on the structural steel during the cleaning and blasting process. If requested by the Engineer, the Contractor shall provide the access and time window to the Engineer to inspect and document the structural steel section loss after the cleaning and blasting operation.

**METHOD OF MEASUREMENT**

Item 961.211 will be measured for payment by the Square Foot of structural steel cleaned (full removal) and painted, complete in place.

The area measured for payment shall be the total of the horizontal and vertical plane areas to the limits of the over-painted area to complete repairs.

**BASIS OF PAYMENT**

Item 961.211 will be paid at the Contract unit price per Square Foot which price shall include all labor, materials, equipment, surface preparation, painting, environmental protection, containment of the work areas, waste disposal, furnishing work barge if required, and all incidental costs required to complete the work.

Payment areas considered incidental shall include any existing stiffeners, diaphragms, and cross bracing remaining in place cleaned and painted, new vertical projections from additional steel thickness of repair plates, bolts, nuts, or additional stiffeners. Incidental to this item are all costs associated with the design and installation of the required containment system/work platform and working barge.

**ITEM 961.211** (Continued)

Incidental to this item are all costs associated with hazardous waste removal including the safe removal and disposal of accumulated pigeon waste and other toxic contaminants, and the design, installation, and final removal of the required containment system/work platform. The Engineer shall receive a copy of the hazardous waste manifest before final payment is made.

After the final coat of paint has cured, a seal shall be placed around the edges of all high strength bolted repair plates in contact with original steel. The seal will be incidental to this item and shall be compatible with the paint system being used. The Contractor shall submit a catalogue of the material to be used to the District for review and approval prior to use.

**SPECIAL NOTES REGARDING PREVAILING WAGE REQUIREMENTS**

Note that the erection and dismantling of scaffolding, rigging and containment for bridge painting work is subject to the “Painter(Bridges/Tanks)” prevailing wage rate. This includes surface preparation, including removal of all types of paint on bridges, the application of paint and the clean-up of debris resulting from paint removal operation on bridges, pursuant to the determination by the Massachusetts Department of Labor Standards’ 12/23/2009 “Notice Concerning the Removal and Application of Paint on Bridges and Tanks.”

**ITEM 994.1****TEMPORARY PROTECTIVE SHIELDING****SQUARE FOOT**

The work under this Item consists of furnishing, installing, maintaining, removing and disposing of existing shielding system on and under bridge(s), in locations required by the Engineer.

The work under this Item shall provide for the protection of traffic, persons, and facilities on the roadway beneath bridges from falling debris during the removal of the unsound concrete from bridge decks, parapets, copings and sidewalks. This shall be accomplished by the utilization of adequate shielding methods.

No portion of the bridge deck shall be removed until the protective shielding is in place and complete.

Note that some of the bridges, due to their height (vertical clearance), will require special lifting equipment in order to place shielding for the assigned bridge repair work. Any equipment necessary to erect forms will be considered incidental to this item.

Any existing formwork on the bridge shall also be removed and disposed by the Contractor away from the job area, at no additional expense.

All shielding shall meet the following requirements:

1. Temporary Protective Shielding must be used on bridges over roadways, railroads, and waterways during full depth excavation and when, in the opinion of the Engineer, there is the possibility of dislodging concrete from the bottom of the deck, parapets or coping. In some cases, the Contractor may be able to utilize the bottom flanges of existing steel beams as supports for the protective shielding. However, the Contractor will not be permitted to weld onto, drill into, or cut any existing structural steel beams.
2. The Contractor shall submit drawings and calculations stamped by a Professional Engineer of the appropriate discipline registered in Massachusetts of the proposed temporary shielding to the Engineer for approval prior to its installation. The drawings shall include details of all connections, brackets, and fasteners. However, when the spacing between existing steel beams is 70 inches or less, the Contractor may utilize a wood plank shielding scheme.
3. Shielding shall be designed to safely withstand all loads that it will be subjected to. The allowable design stresses shall be in accordance with AASHTO Standard Specifications for Highway Bridges, 17<sup>th</sup> Edition. The design shall also include a description of the equipment and construction methods proposed for the deck, parapet, or coping excavation and the maximum size of the area being excavated. The shielding shall also be designed to withstand the maximum size of the excavated area should it fall during excavation or removal. No debris shall be swung over traffic, on or below the bridge.
4. Shielding shall be designed such that impact on traffic during installation and removal shall be minimal. The Contractor shall submit the traffic plan to the Engineer for approval



**ITEM 994.1** (Continued)

5. The shielding shall extend a sufficient distance above and beyond the deck overhang at the fascia where concrete excavation is required outside the fascia beams. The shielding shall extend the length of the damaged or distressed portion of the deck a length of sufficient distance to do the required deck demolition. Also, the width of shielding shall completely extend over the travel lanes and shoulders of the highway below and shall extend a minimum of one beam width in the transverse direction beyond the limits of the excavation.
6. The area for shielding shall be approved by the Engineer prior to any installation of any shielding. The Contractor may utilize the bottom flanges of existing beams as supports for the protective shielding. However, the Contractor will not be permitted to weld onto, drill into, or cut any existing structural steel beams. All spaces along the perimeter of the shielding and at the seams shall be sealed to prevent dust, water, and debris from escaping and falling onto traffic below the bridge.
7. The Engineer may request that the shielding be designed so that it may also serve as false work (forms) for all areas of full-depth concrete replacement/repair.
8. The shielding shall not decrease the minimum vertical bridge clearance to the roadway unless otherwise approved by the Engineer.
9. The shielding shall be maintained and remain in place until the strength of the concrete used to repair the deck has cured and reached the design strength requirement, except where shielding needs to be removed and reset to install forming for the areas of full depth repair. The shielding shall remain the property of the Contractor and shall be removed by the Contractor from the site when no longer needed.

If the Contractor's operations damage any existing portions of the bridge that are to remain, such damage shall be repaired at the Contractor's own expense. All materials used in the temporary shielding system shall become the property of the Contractor and shall be removed from the site upon the completion of the project.

**METHOD OF MEASUREMENT**

Item 994.1 will be measured for payment by the Square Foot of temporary protective shielding installed, maintained, and removed upon completion of repair work as required by the Engineer.

**BASIS OF PAYMENT**

Item 994.1 will be paid for at the Contract unit price per Square Foot, which price shall include all labor, materials, equipment, removal and disposal of all debris, shielding furnishing and installation, maintenance, final removal upon completion of repair work, and all incidental costs required to complete the work.

Payment of 60% of the Square Foot of this item will be made upon complete installation. The remaining 40% of the Square Foot of this Item will be paid following complete removal.

Compensation to provide Engineering Services, when required, will be separately reimbursed as a Non-Bid Item.

THIS PAGE INTENTIONALLY LEFT BLANK

DOCUMENT A00804

# **DAILY FORCE ACCOUNT REPORT**

THIS PAGE INTENTIONALLY LEFT BLANK

**DAILY FORCE ACCOUNT REPORT**

Contractor/Utility: \_\_\_\_\_ Project: \_\_\_\_\_  
 Contract No: \_\_\_\_\_ Agreement No: \_\_\_\_\_ FAP No: \_\_\_\_\_  
 Contract Date: \_\_\_\_\_ Agreement Date: \_\_\_\_\_ Prime:  Sub:

Date of Work: \_\_\_\_\_ Work Item and Description: \_\_\_\_\_

**LABOR**

Classification	No.	Time Worked	No. Hours	Line Total
		to		
		to		
		to		
		to		
		to		
		to		
		to		
		to		
		to		

**EQUIPMENT**

Description	No.	Hours of Op.	No. Hours	Line Total
		to		
		to		
		to		
		to		
		to		
		to		
		to		
		to		
		to		

**MATERIALS**

Description	Quantity	Unit

**SALVAGE**

Description	Quantity	Unit

Location and Description of Work: \_\_\_\_\_  
 \_\_\_\_\_  
 \_\_\_\_\_  
 \_\_\_\_\_  
 \_\_\_\_\_  
 \_\_\_\_\_

Received: \_\_\_\_\_  
 (Title) \_\_\_\_\_  
 Massachusetts Department of Transportation  
 Date: \_\_\_\_\_

Signed: \_\_\_\_\_  
 (Title) \_\_\_\_\_

**MATERIAL USED, SALVED, ETC.**

	Charged In				Charged Out				Permanent Work	Temporary Work	Old Items Removed
	Quantity		Date	Quan	Rate	Amt	Quantity				
	New	Fit					Fit	Scrap			

**INSTRUCTIONS**

1. Note whether all material chargeable to the project it is used temporarily or remains permanently in the work
2. Use the three columns on the right to indicate the disposition of the item, using a check mark (✓) in the proper column opposite the referenced item.
3. Use the last column to designate those items which are already in use and were installed prior to any elimination work but which must be removed due to this work. Do not refer to such items under the column "Charged In" but do show a salvage allowance.
4. Indicate the quality of the item with a check mark (✓) as "New", "Fit" or "Scrap, in the appropriate column.

I, \_\_\_\_\_ do hereby certify that I am the employee of \_\_\_\_\_ located at \_\_\_\_\_ and that I am in a position to have full knowledge that the accounts herein shown are a substantially accurate statement of labor employed, equipment operated, and material used and/or salvaged on the project on the \_\_\_\_\_ Day of \_\_\_\_\_, \_\_\_\_\_ in charge of force account operations in connection with the construction of Project/Agreement No: \_\_\_\_\_

Received: \_\_\_\_\_ Signed: \_\_\_\_\_  
 (Title) \_\_\_\_\_ (Title) \_\_\_\_\_  
 Massachusetts Department of Transportation  
 Date: \_\_\_\_\_ Date: \_\_\_\_\_



**WORK  
ZONE  
SAFETY**

*Temporary Traffic Control*

*Typical Details and  
Massachusetts Guidelines  
for MassDOT, Municipalities,  
Utilities, and Contractors*

**SHEET INDEX (1 OF 3)**

<b><u>GENERAL</u></b>	<b><u>PAGE</u></b>
NOTES AND GUIDELINES.....	1-9
FIG. 1: TYPICAL TRAFFIC CONTROL DEVICES.....	10
FIG. 2: PAVEMENT EDGE DROP-OFF GUIDANCE.....	11
FIG. 3: TYPICAL DEVICE SPACING; (AT 30 MPH).....	12-13
FLAGGING GUIDANCE.....	14-15
FIG. 4-5: TYPICAL PEDESTRIAN DEVICES.....	16-17
 <b><u>STATIONARY OPERATIONS</u></b>	
FIG. 6: TWO LANE UNDIVIDED ROADWAY; HALF OF ROADWAY CLOSED; WORK NEAR CURVE.....	18-19
FIG. 7: TWO LANE UNDIVIDED ROADWAY; HALF OF ROADWAY CLOSED.....	20-21
FIG. 8: TWO LANE UNDIVIDED ROADWAY; SHOULDER CLOSED.....	22-23
FIG. 9: TWO LANE UNDIVIDED ROADWAY WITH TRAVERSABLE SHOULDER; HALF OF ROADWAY CLOSED; MAINTAIN TWO-WAY TRAFFIC.....	24-25
FIG. 10: FOUR LANE UNDIVIDED ROADWAY; RIGHT LANE CLOSED.....	26-27
FIG. 11: FOUR LANE UNDIVIDED ROADWAY; LEFT LANE CLOSED.....	28-29
FIG. 12: FOUR LANE UNDIVIDED ROADWAY; HALF OF ROADWAY CLOSED.....	30-31
FIG. 13: MULTILANE DIVIDED ROADWAY; RIGHT LANE CLOSED.....	32-33
FIG. 14: MULTILANE DIVIDED ROADWAY; LEFT LANE CLOSED.....	34-35
FIG. 15: MULTILANE DIVIDED ROADWAY; CENTER LANE OR RIGHT/CENTER LANES CLOSED.....	36-37
FIG. 16: MULTILANE DIVIDED ROADWAY; CENTER LANE OR LEFT/CENTER LANES CLOSED.....	38-39



**SHEET INDEX (2 OF 3)**

<b><u>STATIONARY OPERATIONS (CONT.)</u></b>	<b><u>PAGE</u></b>
FIG. 17: MULTILANE DIVIDED ROADWAY; RIGHT SIDE OF OFF RAMP CLOSED.....	40-41
FIG. 18: MULTILANE DIVIDED ROADWAY; LEFT SIDE OF OFF RAMP CLOSED.....	42-43
FIG. 19: MULTILANE DIVIDED ROADWAY; ROADWORK BEYOND ON RAMP.....	44-45
FIG. 20: MULTILANE DIVIDED ROADWAY; ROADWORK BEYOND OFF RAMP.....	46-47
FIG. 21: MULTILANE DIVIDED ROADWAY; TYPICAL RAMP CLOSURE.....	48-49
FIG. 22: MULTILANE DIVIDED ROADWAY; TYPICAL CLOVERLEAF RAMP CLOSURE.....	50-51
FIG. 23: MULTILANE DIVIDED ROADWAY; TYPICAL RAMP CLOSURE; ADVANCE SIGNING.....	52-53
FIG. 24: FOR MULTILANE DIVIDED ROADWAY; PLACEMENT OF TEMPORARY PORTABLE RUMBLE STRIPS.....	54-55
 <b><u>MOBILE OPERATIONS</u></b>	
NOTES FOR MOBILE OPERATIONS.....	56
FIG. 25: ANY ROADWAY; BEYOND RIGHT SHOULDER.....	57
FIG. 26: ANY ROADWAY; SHOULDER.....	58
FIG. 27: DIVIDED ROADWAY; MEDIAN WORK.....	59
FIG. 28: UNDIVIDED TWO LANE ROADWAY; HALF OF ROADWAY CLOSED.....	60
FIG. 29: MULTILANE DIVIDED ROADWAY; LEFT LANE.....	61
FIG. 30: MULTILANE DIVIDED ROADWAY; RIGHT LANE.....	62
FIG. 31: MULTILANE DIVIDED ROADWAY; CENTER LANE.....	63
FIG. 32: POST-STORM CLEANUP OPERATION.....	64

**SHEET INDEX (3 OF 3)**

**EMERGENCY RESPONSE**

**PAGE**

NOTES FOR TRAFFIC EMERGENCY/INCIDENT OPERATIONS... 65

FIG. 33: ANY ROADWAY; SHOULDER ENCROACHMENT..... 66

FIG. 34: TWO LANE ROADWAY; NO SHOULDER; TRAVEL  
LANE ENCROACHMENT.....67

FIG. 35: TWO LANE ROADWAY; TRAVERSABLE SHOULDER;  
SINGLE LANE ENCROACHMENT..... 68

FIG. 36: TWO LANE ROADWAY; TRAVERSABLE SHOULDER;  
CENTER OF ROADWAY..... 69

FIG. 37: MULTILANE DIVIDED ROADWAY; RIGHT LANE..... 70

FIG. 38: MULTILANE DIVIDED ROADWAY; LEFT LANE.....71

FIG. 39: MULTILANE UNDIVIDED ROADWAY; LEFT LANE..... 72

FIG. 40: MULTILANE DIVIDED ROADWAY; MIDDLE LANE;  
APPROACH FROM LEFT.....73

FIG. 41: MULTILANE DIVIDED ROADWAY; MIDDLE LANE;  
APPROACH FROM RIGHT.....74

**TRAFFIC SIGNAL REPAIR WORK AT INTERSECTION**

FIG. 42: MULTILANE UNDIVIDED ROADWAY; LEFTMOST OR  
LEFT TURN LANE.....75

FIG. 43: TWO LANE UNDIVIDED ROADWAY; ONE LEG OF  
INTERSECTION..... 76

FIG. 44: MULTILANE UNDIVIDED ROADWAY; CENTER OF  
INTERSECTION..... 77

**PEDESTRIAN DETAILS**

FIG. 45: PEDESTRIAN BYPASS.....78

FIG. 46: TEMPORARY SIDEWALK CLOSURE..... 79

**BIKE LANE DETAILS**

FIG. 47: BIKE LANE CLOSURE.....80-81

## INTRODUCTION

This guide has been prepared to assist in the planning and installing of temporary traffic controls in maintenance, utility, or short-term construction work areas (work lasting 10 hours or less). This guide serves to assist with the many decisions that must be made for each work site. Special planning for traffic control is necessary on a case by case basis because conditions can vary widely among work locations. **Since this guide cannot cover every situation, representative illustrations covering typical short-term construction, maintenance, and utility operations are presented.**

**All typical traffic control device setups illustrated should be considered as guides.** The traffic control devices that are shown, the arrangement or position of the devices, and the distances prescribed in the tables are based on the Federal Highway Administration's (FHWA) Manual on Uniform Traffic Control Devices (MUTCD) and the Massachusetts Amendments to the MUTCD (MA Amendments), but these illustrations only present minimum standards. The provision of safe work zones for all roadway users and roadway workers affected by these activities is paramount. Traffic controls may be expanded or improved upon whenever deemed necessary. Traffic movement through the work site all traffic control devices shall be periodically observed and inspected at all locations.

If necessary, Part 6 of the MUTCD and the MA Amendments, Chapter 17 (Work Zone Management) of MassDOT's Project Development & Design Guide, and the "Traffic Engineering and Safety Section" of the MassDOT web site: (<https://www.massdot.state.ma.us/highway/Departments/TrafficandSafetyEngineering.aspx>), as well as MassDOT District offices can provide additional guidance, information, and suggestions for work zone setups.

## RESPONSIBILITIES FOR TRAFFIC CONTROL

Short-term construction, maintenance, and utility work on or near the roadway creates a potentially hazardous situation, typically requiring the use of temporary traffic controls. These controls are important to protect both work crews and the road users. It is the responsibility of each maintenance foreman to establish and maintain safe and effective controls.

Usually the supervisor, working with the crew, plans the traffic control procedures for proposed work sites. The foreman is responsible for re-requesting, storing, and maintaining all traffic control devices necessary for their crews.

The foreman is responsible for placing the devices according to these guidelines. They must inspect each installation and observe traffic flow through the area. The foreman is generally authorized to make adjustments to the original installations that, in their judgment, are necessary to improve the control of traffic and establish greater safety.

All necessary traffic control devices must be installed before work begins and properly maintained during the work period. They must also be removed as soon as they are no longer relevant to the roadway conditions.

PAGE 2

In situations such as night time road or lane closures, detours, or other unusual conditions on state highways, the District Traffic Maintenance Engineer (DTME) should be advised. If the DTME is absent, the section foreman shall follow the instructions of the District Maintenance Engineer.

### **TRAFFIC CONTROL DEVICES**

Traffic control devices regulate the movement of road users, warn of unexpected or unusual roadway conditions, and inform them how to maneuver safely through or around the work area. All signs, channelizing devices, barricades, and other miscellaneous traffic control devices should work together to guide traffic safely and efficiently. Common temporary traffic control devices are outlined and described below.

#### **Signs**

Temporary traffic control zone (TTCZ) signs are the primary means of providing information and directions to roadway users. All signs must be retroreflective per MassDOT's latest standard.

Warning signs call attention to unexpected conditions and to situations that might not be readily apparent to road users on or adjacent to a roadway. Warning signs alert road users to conditions that might call for a reduction of speed or an action in the interest of safety and efficient traffic operations. Nearly all warning signs for construction and work areas have black legends and borders on a fluorescent orange background.

Regulatory signs shall be used to inform road users of selected traffic laws or regulations and indicate the applicability of the legal requirements. Regulatory signs typically have black legends and borders on a white background.

#### **Channelizing Devices**

When used properly, traffic cones, reflectorized plastic drums, and barricades guide traffic through the work area along an appropriate travel path. It takes roadway users a certain distance along the roadway to safely move away from the upcoming active work site. These transition distances are based on the following taper length (L) formulas:

$L = WS^2/60$  for speeds of 40 mph or less; or

$L = WS$  for speeds of 45 mph or more; where

- $L$  = minimum length of taper in feet,
- $S$  = posted speed limit or typical travel speed in miles per hour prior to the work, and
- $W$  = width of lane closure in feet.

The spacing of channelizing devices (in feet) is approximately equal to the existing speed of traffic (in mph).

#### **Warning Lights**

Rotating beacons and other flashing lights mounted on work vehicles, signs, or channelizing devices help alert roadway users to the work area. They may also be used to warn roadway users of hazards within the work area. The first 10 drums in any taper shall be equipped with sequential flashing lights.

### **Arrow Boards**

Arrow boards are a special type of sign that are highly visible work zone warning devices. They are particularly effective on highways, where both speed and volume are high. Arrow boards in the non-directional, CAUTION, mode (four corner flashing) may be used to indicate that a shoulder is closed. Arrow boards in the arrow mode shall only be used when a travel lane is dropped on a multi-lane road and one lane of traffic must merge with another. All arrow boards should be located at the beginning of each lane or shoulder closure taper without extending outside of it. Arrow boards shall flash at a rate of 25 to 40 flashes per minute. Arrow boards shall not be used to indicate a lane shift.

### **BASIC REQUIREMENTS**

In every work situation, the temporary traffic control setup must: Give roadway users sufficient advance warning of the work area; advise roadway users of the proper actions to take and travel paths to follow; and provide protection to roadway users, workers, and the work area. These three general requirements can be met as outlined below.

#### **Provide Advance Warning**

Warning devices along the approaches to a work area alert roadway Users to changes to road and operating conditions. Roadway users are usually alerted to these dangers via a sign or series of signs installed in the same order as the roadway user generally would expect to see them on long-term construction projects.

The initial project limit sign is usually a general warning such as "ROAD WORK 1500 FT". Other operational warning signs then provide the roadway user with more specific information about the situation. A minimum of three advance warning signs (the initial project limit sign and two operational warning signs) is recommended when work is located on the traveled way. Warning lights and flags can be used to attract attention to the signs. A highly visible work area helps reinforce the advance warnings.

#### **Advise and Direct Travelers**

Operational warning signs provide information to the road-way user such as the type of work being performed, special conditions to watch for, or actions to take. These include signs such as, SHOULDER WORK, RIGHT LANE CLOSED, DETOUR 500 FT, ROAD CLOSED to THRU TRAFFIC, POLICE OFFICER AHEAD, etc. All of these signs must be located far enough in advance of the work area that the roadway user has sufficient time to react to them appropriately. For projects in Urban Areas, see detail: Typical Device Spacing for minimum sign spacing.

#### **Protect Travelers, Workers, and the Work Area**

The primary protection of any work area is its own visibility. Traffic cones, reflectorized plastic drums, portable breakaway barricades, etc. are used to make the work area visible and separate workers from traffic.

PAGE 4

Other devices, such as flashing lights, flags, delineators, temporary lighting, and portable changeable message signs (PCMS) can be used to provide additional emphasis and visibility.

Workers must protect themselves by being alert to their work situation, wearing safety vests and hard hats, and by facing traffic whenever possible.

Work vehicles can also add protection when they are equipped with truck mounted attenuators, rotating beacons, flashing lights, flashing arrow boards, etc. and are parked between workers and oncoming traffic. However, workers should not position themselves between two closely parked vehicles. No private personal vehicles are allowed within the work site.

### PLANNING GUIDELINES

Decisions regarding selection of work area traffic control devices require a knowledge and understanding of the specifics of each work zone. As there may be vast differences between situations, three main variables need to be considered prior to determining the need for, or the selection of, traffic control devices: 1) location of work, 2) type of roadway, and 3) speed of traffic.

Compiling information about these variables will help with planning a safe work area control. Each of these variables is explained below.

#### Location of Work

The choice of traffic controls needed for a short-term construction, maintenance, or utility operation depends upon the work zone's location. As a general rule, the closer the active work site is to the roadway, the more control devices are needed. Work can take place:

- Away from the shoulder or edge of pavement. No special devices are needed if work is confined to an area 15 or more feet from the edge of the shoulder. A general warning sign, such as ROAD WORK AHEAD, should be used if workers and equipment must occasionally move closer to the roadway.
- On or near the shoulder/ edge of pavement. This area should be signed as if work were on the road itself, since it is part of the roadway users' recovery area. Advance warning and operational signs are needed, as well as channelization devices to direct traffic and keep the work area visible to roadway users.
- On the median of a divided highway. Work in this location may require traffic control in both directions of traffic. Advance warning and channelization devices should be used if the median is narrow.
- On the roadway. This condition requires detailed protection for workers and sufficient warning to roadway users. Advance warning must provide a general message that work is taking place as well as information about specific hazards and specific actions the roadway user must take.

### TYPE OF ROADWAY

The characteristics of the roadway also have an important influence on the selection of work area traffic control. The roadway, itself, may present special hazards. You should plan for maximum protection, using the worst hazard present as your guide to signing the work area. Some general considerations are described below for road conditions.

**One-way roads:** A one-way road requires signage on both sides of the road if it carries two or more lanes in one direction, ensuring roadway users in all lanes are alerted and informed.

#### Two-way roads:

- **Undivided:** Two-way, undivided roads will usually require controls for both directions of traffic. When the active work site is well off the roadway, controls for the opposite lane may be eliminated.
- **Divided:** Work on divided multi-lane roadways can often be handled as work along a one-way road (i.e. signs are provided along both sides of the roadway along the direction affected). If the work is in the median, both directions of traffic must be controlled, and both approaches should be double signed (i.e. have all 3 advance warning signs on both sides of each direction).

### EFFECTS OF SPEED ON WORK ZONES

Speed is an important consideration in the use of work area traffic control devices. As a general rule, the greater the speed of traffic approaching a work area, the greater the size, number, and spacing of control devices.

**Size.** The standard size for most warning signs is 36 x 36 inches on conventional roadways and 48 x 48 inches on freeways and expressways. Signs larger than the standard 36 x 36 inches may be desirable on high-speed conventional roads.

**Position.** Install signs far enough in advance of the work area so the roadway users have time to react to them (see charts associated with diagrams for spacing).

### OTHER FACTORS

**Sight Obstructions.** To ensure safety, work areas must be visible. Assess the placement of the temporary traffic control devices by driving through the area, and determine if the devices can be easily seen and provide sufficient time for roadway users to react in a safe manner. Extra precaution should be enacted in areas where horizontal or vertical curves may obstruct a roadway user's clear view of road activities ahead.

**Police/Flaggers.** It should be noted that the MUTCD does not require police/flaggers for stationary setups. If police/flaggers are used, a police/flagger ahead sign should be used in advance of any point where the police/flagger is stationed to control road users.

## PROCEDURES FOR WORK AREA TRAFFIC CONTROL

### 1. PLAN YOUR WORK

**Inspect** location of work area and its surroundings.

#### **Analyze:**

- Location of work in relation to the traveled way, intersecting road-ways, driveways, and sight distances;
- Type of roadway and traffic involved; and
- Volume and speed of traffic.

**Meet and discuss** the work and necessary traffic control with the crew.

**Study** representative illustrations in this guide to develop a temporary traffic control plan (TTCP).

#### **Other Considerations:**

- Base your traffic control plan on the premise that all roadway users are unfamiliar with the area.
- The closer the work area location is to traffic, the more controls are needed.
- Plan for maximum protection.
- Select and inspect the temporary control devices needed (including all warning signs), if they are not in good condition, REPLACE THEM!
- Then collect and transport them to the work site.
- Determine their proper placement.
- Install signs and other traffic control devices prior to allowing personnel or equipment onto the roadway.
- Make sure signs are reflective, accurate, clean, and meet specifications. Completely cover any existing permanent signs that will conflict with the messages of the new work area control signs.

### 2. INSTALLING/REMOVING TEMP. TRAFFIC CONTROL DEVICES

Care must be exercised when installing and removing temporary traffic control (TTC) devices. The traffic control needed to perform the operation safely is dictated by the location on the roadway the operation will occur: in a shoulder or a lane, in the left lane or right, etc. In all cases, installing TTC begins and ends as a mobile operation.

A shadow vehicle with a truck mounted attenuator (TMA) shall be used to protect workers installing and removing TTC devices on all roadways with a posted speed limit of 45 MPH or greater as directed by the engineer. TTC devices shall not be installed or removed from a shadow vehicle with a TMA. TTC devices shall be installed or removed from a work operation vehicle only and a shadow vehicle with a TMA shall be used to protect the workers installing or removing the devices.



## **PROCEDURES FOR WORK AREA TRAFFIC CONTROL (CONT.)**

### **3. INSTALL TRAFFIC CONTROL DEVICES AT WORK SITE**

#### **FOR LOWER SPEED ( $\leq 40$ MPH) ROADWAYS:**

- 1) All devices shall be installed in order with the flow of traffic.
- 2) Where one direction of traffic is being affected, the first sign installed should be the sign farthest from the work site, and on the same side as the work.
- 3) Where two directions of traffic are affected, install signs for opposing traffic first, starting with the sign farthest from the work area. When signs for opposing traffic have been installed, install signs on the same side as the work area, again beginning with the sign farthest from the active work site.
- 4) Once signs are in place, other traffic control devices shall be installed in the same manner as the signs.

#### **FOR HIGHER SPEED ( $\geq 45$ MPH) ROADWAYS:**

- 1) All devices shall be installed in order with the flow of traffic.
- 2) Install all advance warning signs, beginning with the ROAD WORK XXX (W20-1) sign and ending with the END ROAD WORK/DOUBLE FINES END (MA-R2-10E) sign.
- 3) Install all signs beginning with the opposite side which will be closed (for a right lane closure; first, install all signs on the left side (shoulder) and then install all signs on the right side (shoulder). No signs shall be erected on the roadway unless delineated by traffic control devices.
- 4) If required, install shoulder taper as the mobile operation advances.
- 5) Install arrow board on the shoulder prior to the merging taper or as close to the beginning of the merging taper as possible.
- 6) Install channelizing devices to form a merging taper. Use of a shadow vehicle with a TMA during installation is required on roads with speed limits of 45 MPH or greater or as directed by the Engineer.
- 7) Install traffic control devices along the buffer space at the appropriate spacing.
- 8) Continue placing devices along the work space at the appropriate spacing.
- 9) Install devices for the termination area as necessary.
- 10) Place the shadow vehicle with a TMA in advance of the first work crew or hazard approached by motorists. Multiple shadow vehicles may be required based on the number of lane and shoulder closures implemented.

### **4. INSPECT WORK AREA SIGNING AND CONTROL DEVICES**

- 1) Assess the placement of the temporary traffic control devices by driving through the work area. All approaches to the work zone should be checked.
- 2) Ensure roadway users will have sufficient time to read signs and react in a safe manner.

### PROCEDURES FOR WORK AREA TRAFFIC CONTROL (CONT.)

- 3) Check visibility of entire work area. If approaching roadway users can't see the work area well, or if they can't see ahead to traffic that may already be queued on the approach because of the work, additional traffic control devices should be deployed.
- 4) Check to ensure the proper temporary traffic control devices are positioned to protect workers from traffic (where possible).
- 5) Ensure all workers wear safety vests, hard hats, and all other necessary safety equipment. All worker safety gear should be in good condition. All reflective gear should be clean and highly visible in the dark.
- 6) Record in the log book the number and location of all signs and devices.

#### Considerations:

- Work area signs should never be blocked from view or obscured by vegetation, existing signs, or other obstructions.
- Flags, flashing lights, and edge line traffic cones can be used to improve visibility.

### 5. REMOVE TRAFFIC CONTROL DEVICES AT WORK SITE

**All workers and equipment should be clear from work site BEFORE removing signs and other devices.**

#### FOR LOWER SPEED ( $\leq 40$ MPH) ROADWAYS:

- 1) Remove signs and other devices within the delineated area when work is complete.
- 2) Remove other traffic control devices in the reverse order in which they were installed
- 3) Remove signs in the reverse order in which they were installed (i.e. sign closest to the work area to be removed first).
- 4) When the operation is complete, uncover any existing permanent signs covered in Step 2.
- 5) Record in the log book the time at which the signs were removed.

#### FOR HIGHER SPEED ( $\geq 45$ MPH) ROADWAYS:

All TTC devices for a stationary lane closure on a multi-lane roadway, except advance warning signs, should be removed against the flow of traffic in the following sequence:

- 1) Remove the channelizing devices starting from the end of the activity area working back to the widest part of the merging taper.
- 2) A shadow vehicle with TMA shall be positioned to protect workers removing devices and work backwards as the setup is removed from the roadway.

### PROCEDURES FOR WORK AREA TRAFFIC CONTROL (CONT.)

- 3) Place the removal vehicle on the shoulder, and remove the channelizing devices from the merging taper by hand onto the work vehicle.
- 4) Remove the arrow board once traffic is clear and it is safe to do so.
- 5) Circle back and moving with the flow of traffic, remove the advance warning signs starting with the opposite side from previous lane closure first.
- 6) At no time shall workers run across the multilane roadway to remove signs on both sides of the road simultaneously.
- 7) Record in the log book the time at which the signs were removed

### RAMP FACILITIES

At all times it is necessary to control the on and off-ramp traffic during the installation and breakdown of traffic control devices. Use of temporary traffic slow-downs or rolling roadblocks is recommended to allow for the safety of workers handing temporary traffic control devices on ramp facilities. A shadow vehicle with a TMA shall be used to protect the workers installing or removing the devices. At no time shall the work operation vehicle be used as the shadow vehicle with the TMA.

### USE OF THIS GUIDE

Illustrations showing minimum standards for short-term construction, maintenance, and utility operations are arranged in this guide by type of operation. The users of this guide should compare all illustrated examples and examine their differences. After gathering information about the work zones using the general guidelines as outlined, proceed as follows:

- 1) Turn to the Index. Consider the type of operations and the type of roadway upon which work will occur.
- 2) Select the figure that most closely matches the conditions where you plan to work. Remember that all diagrams represent minimum standards.
- 3) Read the title of the illustration to ensure that it is appropriate to your location. Study the layout of traffic control devices and read all notes.
- 4) Consult the appropriate tables, as directed on each illustration to determine taper length and proper spacing of signs. Notice that distances change when speeds change. Also note that these are guidelines, only, and they must be adapted to your specific work area.
- 5) Use the **“PROCEDURES FOR WORK AREA TRAFFIC CONTROL”** for assistance in completing all necessary steps to provide effective and safe work area traffic control.



**SIGN**

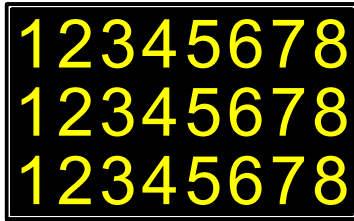

**PORTABLE CHANGEABLE MESSAGE SIGN (PCMS)**

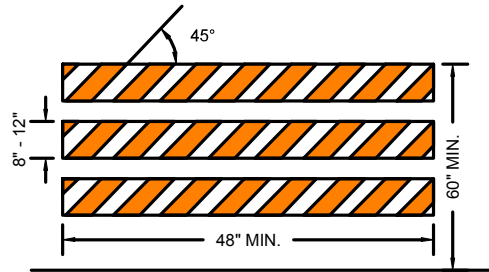

**TYPE III BARRICADE**

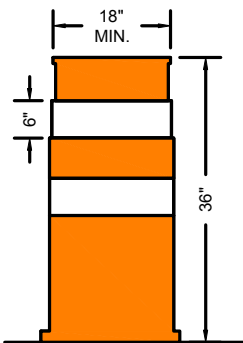

**DRUM**

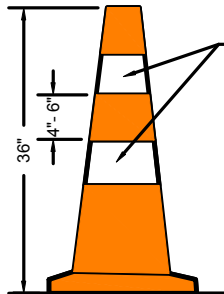

**CONES**

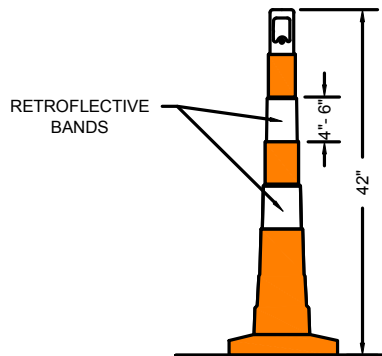

RETROFLECTIVE BANDS

Cones may be used for all daytime operations. For night work, drums should be used to form the taper(s) and cones can be used along the tangent section of the work setup.

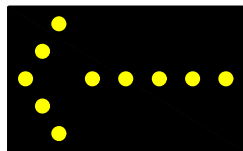

LEFT

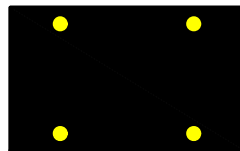

CAUTION

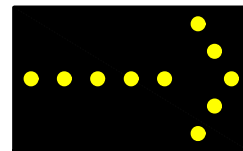

RIGHT

**ARROW BOARD (WITH MODE)**

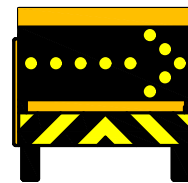

**TRUCK MOUNTED ATTENUATORS**

Truck Mounted Attenuators (TMA) shall be positioned between the start of the work area and the end of the designated buffer zone. The TMAs are to be positioned in each temporarily closed lane. This includes shoulders ( $\geq 8$  feet) whether combined with a travel lane closure or being closed alone. These TMA conditions are required on roadways with speeds of 45 MPH or greater. TMAs can be used on other roadways at the discretion of the engineer. TMAs shall be used for the deployment and removal of all traffic control devices, including all advance warning signs.

### SHORT-TERM PAVEMENT EDGE DROP-OFFS

*Note that this guidance is adopted from the Roadside Design Guide, 4th Edition.*

Pavement drop-offs may occur during paving, excavation, and other construction activities. Drop-offs create hazards for vehicles if not properly mitigated. The following applies for all roads with speed limits greater than 30 mph; for roads with speed limits of 30 mph or less, treatments for pavement edge drop-offs are at the discretion of the Engineer. Drop-offs between adjacent, open travel lanes should not exceed 2", and any drop-off in excess of 3" should not be left unattended without one of these mitigation measures applied.

- Shoulder drop-offs 3" or less adjacent to a shoulder or active travel lane should be mitigated by:
  - ✓ A W8-9 (LOW SHOULDER) sign in advance of and at regular intervals throughout the treatment; or
  - ✓ The placement of drums on the traffic side of the drop-off.

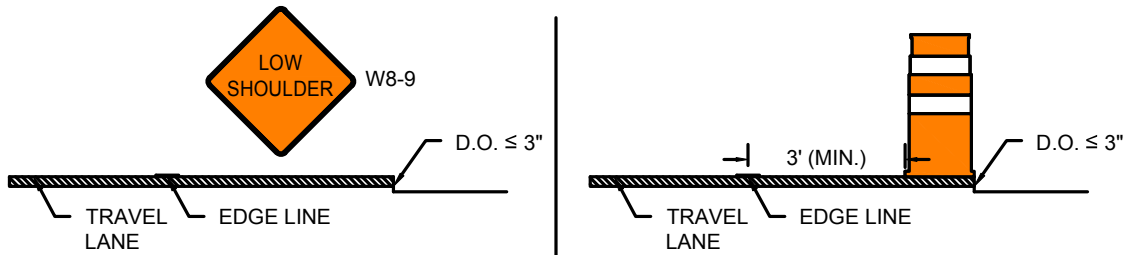

- Shoulder drop-offs greater than 3" but less than or equal to 36" should be mitigated by:
  - ✓ A W8-9 (LOW SHOULDER) sign in advance of and at regular intervals throughout the treatment and the placement of drums on the traffic side of the drop-off, offset at least 3' from the travel lane; or
  - ✓ A W8-9 (LOW SHOULDER) sign in advance of and at regular intervals throughout the treatment and the placement of a temporary wedge of material along the face of the drop-off. The wedge should consist of stable material placed on a 2H:1V or flatter slope.

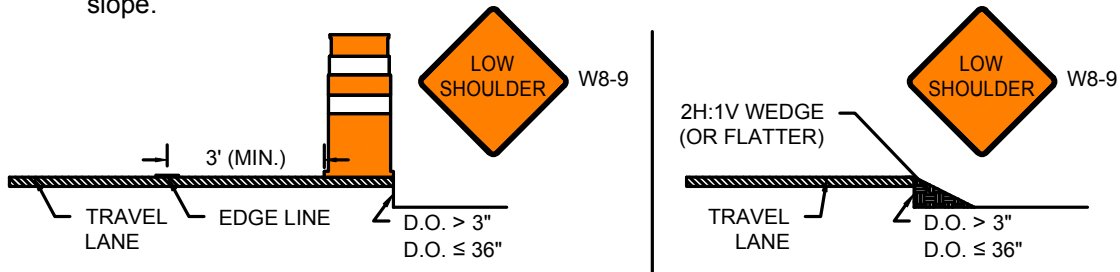

- Shoulder drop-offs greater than 36" must be protected by temporary barrier.

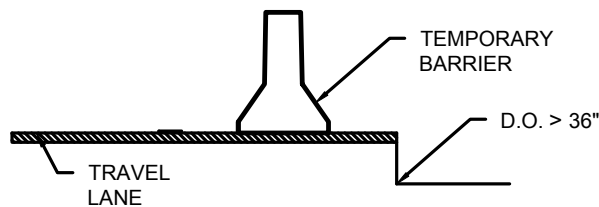

 Massachusetts Department of Transportation Highway Division PAGE 12	Work Zone Safety Standard Details and Drawings	TYPICAL DEVICE SPACING
--	--	------------------------

POSTED SPEED LIMIT (MPH)	SPACING FOR ADVANCE WARNING SIGNS (FT) (A,B,C)	CHANNELIZATION DEVICES (DRUMS OR CONES)			
		TRAVEL LANE CLOSURE LENGTH (L) (FT)	BUFFER ZONE LENGTH (FT)	DEVICE SPACING (FT)	MIN # OF DEVICES*
25-40	500 / 500 / 500	320	305	20	55
45-55	500 / 1000 / 1000	660	495	40	40
60-65	1000 / 1600 / 2600	780	645	40	50









\* NUMBER OF DEVICES BASED ON 400 FT WORK ZONE.

MINIMUM SPACING OF ADVANCE WARNING SIGNS FOR URBAN ROADWAYS	
ROAD TYPE	DISTANCE BETWEEN SIGNS
URBAN (LOW SPEED)	100 FT
URBAN (HIGH SPEED)	350 FT

**NOTES**

1. 40 FT = 10 FT PAVEMENT MARKING + 30 FT SKIP

**LEGEND**

-  WORK ZONE
-  CHANNELIZATION DEVICE
-  FLASHING ARROW BOARD
-  PORTABLE CHANGEABLE MESSAGE SIGN
-  TRUCK MOUNTED ATTENUATOR
-  RADAR SPEED FEEDBACK BOARD
-  POLICE DETAIL OR UNIFORMED FLAGGER
-  TEMPORARY PORTABLE RUMBLE STRIP
-  TYPE III BARRICADE

NOT TO SCALE

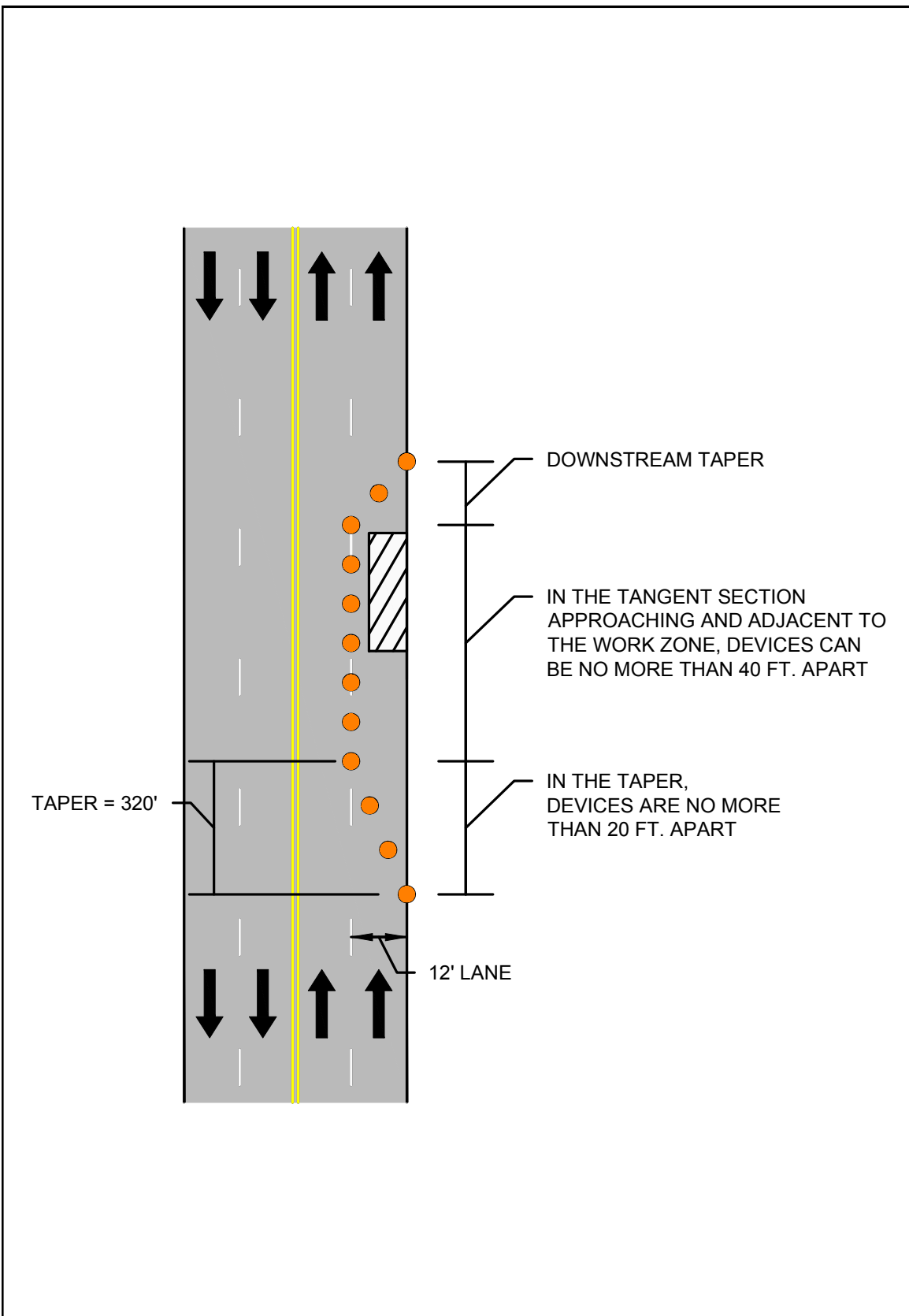

 <p>PAGE 14</p>	<p>Work Zone Safety Standard Details and Drawings</p>	<p>FLAGGING GUIDANCE</p>
--	---	--------------------------

**Guidance for Flagging Operations**

**NOTE:**

A flagger shall always be aware of their surroundings and have a good escape route. A flagger shall never be positioned directly beside or against construction equipment. When a flagger is required to direct traffic in an area where the escape route is partially blocked by a traversable obstruction such as a guardrail, the flagger shall be physically capable of traversing that obstruction. Prior to commencing a project, the supervisor in charge shall review the project, including guardrail areas, for safe flagging stations. The supervisor in charge shall clearly communicate with the flagger(s), indicating any locations where they cannot safely perform their duties.

Each flagger shall be equipped with the following high visibility clothing, signaling, and safety devices:

- 1) A white protective hard hat with a minimum level of reflectivity per the requirements of ANSI, Type I, Class E&G;
- 2) A clean, unfaded, untorn lime/yellow reflective safety vest and pants meeting the requirements of ANSI 107 Class 3 with the words "Traffic Control" on the front and rear panels in minimum two (2) inch (50 millimeter) high letters;
- 3) A 24 inch "STOP/SLOW" traffic paddle conforming to the requirements of Part 6E.03 of the Manual on Uniform Traffic Control Devices (MUTCD), a weighted, reflectorized red flag, flagger station advance warning signage, and two-way radios capable of providing clear communication within the work zone between flaggers, the Contractor, and the Engineer. The traffic paddle shall be mounted on a pole of sufficient length to be seven feet above the ground as measured from the bottom of the paddle;
- 4) A working flashlight with a minimum of 15,000 candlepower and a six inch red attachable wand, a whistle with a working lanyard, and a First Aid kit that complies with the requirements of ANSI Z308.1; and
- 5) An industrial/safety type portable air horn that complies with the requirements of the U.S. Coast Guard.



A "STOP/SLOW" paddle should be the primary hand-signaling device. It shall have an octagonal shape on a rigid handle. Flag use should be limited to emergency situations.



**Properly Trained Flaggers**

- Give clear messages to drivers.
- Allow distance for drivers to react.
- Coordinate with other flaggers.
- Use standard signaling methods.

**Properly Equipped Flaggers**

- Use approved stop/slow paddles.
- Use approved safety apparel.
- Use retroreflective equipment.
- Use hand held radios, as needed.
- All flaggers shall wear safety apparel that meets ANSI Class 3 requirements. The combination of vest and pants is required.

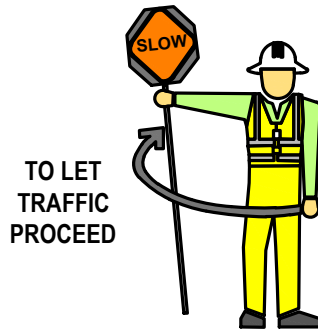

**Proper Flagging Stations**

- Good approach sight distance.
- Highly visible to traffic.
- Stand alone away from other machinery and people.
- Stand on right edge of pavement or shoulder- proceed to centerline only when first vehicle has come to stop.
- Have a good escape route.



**Proper Advance Warning Signs**

- Always use warning signs.
- Allow for reaction distance from signs.
- Remove signs if no longer necessary or not flagging.
- Use free hand in up-and-down motion to help slow traffic.



FIGURE 4  
TYPICAL PEDESTRIAN DEVICES  
(1 OF 2)  
NOT TO SCALE

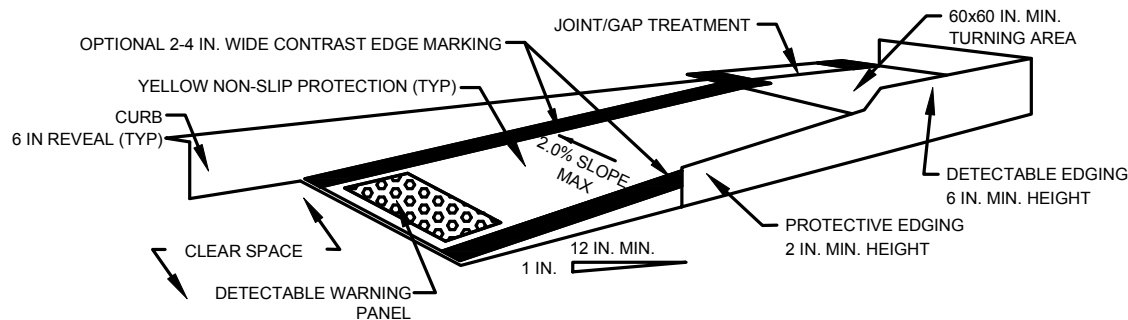

**TEMPORARY CURB RAMP-PARALLEL TO CURB**

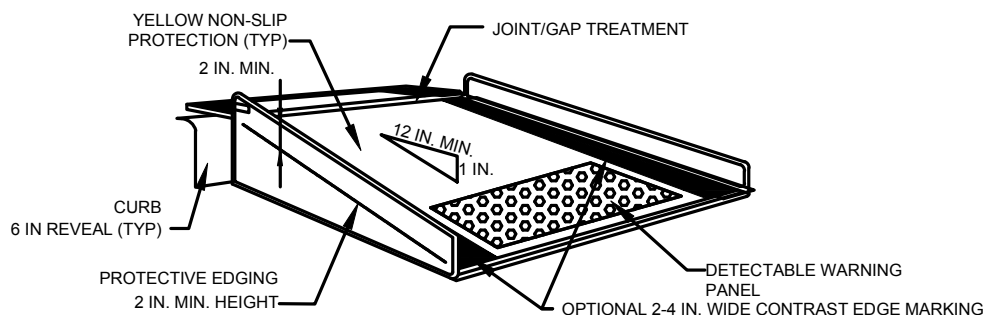

**TEMPORARY CURB RAMP-PERPENDICULAR TO CURB**

**NOTES:**

1. CURB RAMPS SHALL BE 60 IN. MINIMUM WIDTH WITH A FIRM, STABLE, AND NON-SLIP SURFACE.
2. PROTECTIVE EDGING WITH A 2 IN. MINIMUM HEIGHT SHALL BE INSTALLED WHEN THE CURB RAMP OR LANDING PLATFORM HAS A VERTICAL DROP OF 6 IN. OR GREATER OR HAS A SIDE APRON SLOP STEEPER THAN 1:3 (33%). PROTECTIVE EDGING SHOULD BE CONSIDERED WHEN THE CURB RAMPS OR LANDING PLATFORMS HAVE A VERTICAL DROP OF 3 IN. OR MORE.
3. PROTECTABLE EDGING WITH 6 IN. MINIMUM HEIGHT AND CONTRASTING COLOR SHALL BE INSTALLED ON ALL CURB RAMP LANDINGS WHERE THE WALKWAY CHANGES DIRECTION (TURNS).
4. THE CURB RAMP WALKWAY AND LANDING AREA SURFACE SHALL BE OF A SOLID CONTINUOUS CONTRASTING COLOR ABUTTING UP TO THE EXISTING SIDEWALK.
5. CURB RAMPS AND LANDINGS SHOULD HAVE A 1:50 (2%) MAX CROSS-SLOPE.
6. CLEAR SPACE OF 48x48 IN. MINIMUM SHALL BE PROVIDED ABOVE AND BELOW THE CURB RAMP.
7. WATER FLOW IN THE GUTTER SYSTEM SHALL HAVE MINIMAL RESTRICTION.
8. LATERAL JOINTS OR GAPS BETWEEN SURFACES SHALL BE LESS THAN 0.5 IN. WIDTH.
9. CHANGES BETWEEN SURFACE HEIGHTS SHOULD NOT EXCEED 0.5 IN. LATERAL EDGES SHOULD BE VERTICAL UP TO 0.25 IN. HIGH, AND BEVELED AT 1:2 BETWEEN 0.25 IN. AND 0.5 IN. HEIGHT.
10. IF A TEMPORARY PEDESTRIAN RAMP LEADS TO A CROSSWALK, THEN A DETECTABLE WARNING PAD MUST BE ADHERED TO THE BASE OF THE RAMP. IF IT LEADS TO A PROTECTED PEDESTRIAN BYPASS THAT DOES NOT CONFLICT WITH VEHICULAR TRAFFIC, THEN A PAD SHALL NOT BE INSTALLED ON THE RAMP.

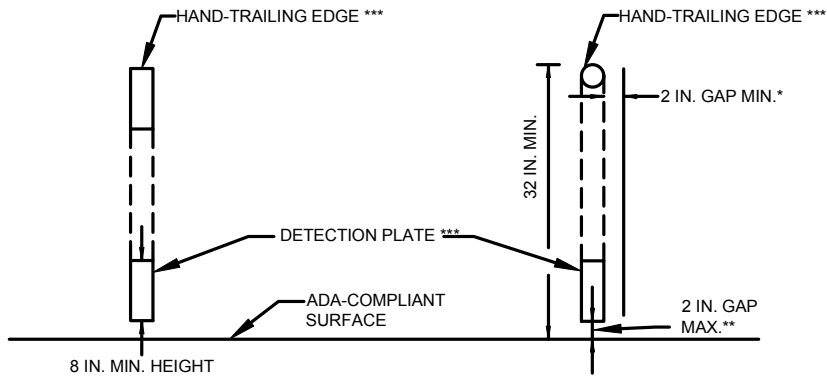

**CROSS SECTION VIEW**

**PEDESTRIAN CHANNELIZING DEVICE**

- \* THERE SHALL BE A 2 INCH GAP BETWEEN THE HAND-TRAILING EDGE AND ITS SUPPORT.
- \*\* A MAXIMUM 2 INCH GAP BETWEEN THE BOTTOM OF THE BOTTOM RAIL AND THE SURFACE MAY BE USED TO PROVIDE DRAINAGE.
- \*\*\* THE HAND-TRAILING EDGE AND DETECTION PLATE SHALL BE CONTINUOUS THROUGHOUT THE LENGTH OF THE PATH SUCH THAT A PEDESTRIAN USER WITH A LONG CANE CAN FOLLOW IT.

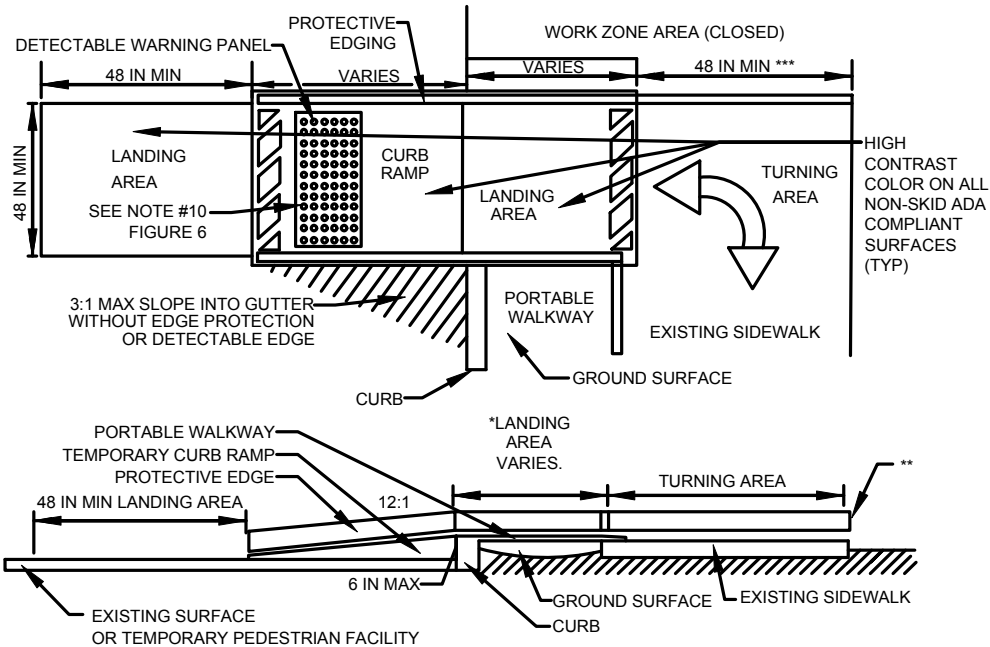

**TEMPORARY CURB RAMP**

- \* LANDING AREA USED TO OVERLAP NON-ADA COMPLIANT SURFACES.
- \*\* DETECTABLE EDGE REMOVED IF A CONTINUOUS SIDEWALK.
- \*\*\* 60 IN. IF AN OBSTRUCTION IS AT BACK OF SIDEWALK.





PAGE 18

Work Zone Safety  
Standard Details  
and Drawings

STATIONARY OPERATIONS  
TWO LANE UNDIVIDED ROADWAY  
HALF OF ROADWAY CLOSED  
WORK NEAR CURVE









POSTED SPEED LIMIT (MPH)	SPACING FOR ADVANCE WARNING SIGNS (FT) (A,B,C)	CHANNELIZATION DEVICES (DRUMS OR CONES)			
		TRAVEL LANE CLOSURE LENGTH (L) (FT)	BUFFER ZONE LENGTH (FT)	DEVICE SPACING (FT)	MIN # OF DEVICES*
25-40	500 / 500 / 500	50	100	20	30
45-55	500 / 1000 / 1000	100	150	40	20

\* NUMBER OF DEVICES BASED ON 400 FT WORK ZONE.

**NOTES**

1. IF POLICE DETAIL/UNIFORMED FLAGGER SUPPORT IS REQUIRED, PROVIDE TWO UNITS.
2. MA-R2-10a LOCATED AT C/2.
3. \*\* = EXTEND ENOUGH SO TAPER IS BEFORE CURVE

**LEGEND**

-  WORK ZONE
-  CHANNELIZATION DEVICE
-  FLASHING ARROW BOARD
-  PORTABLE CHANGEABLE MESSAGE SIGN
-  TRUCK MOUNTED ATTENUATOR
-  RADAR SPEED FEEDBACK BOARD
-  POLICE DETAIL OR UNIFORMED FLAGGER
-  TEMPORARY PORTABLE RUMBLE STRIP
-  TYPE III BARRICADE

NOT TO SCALE

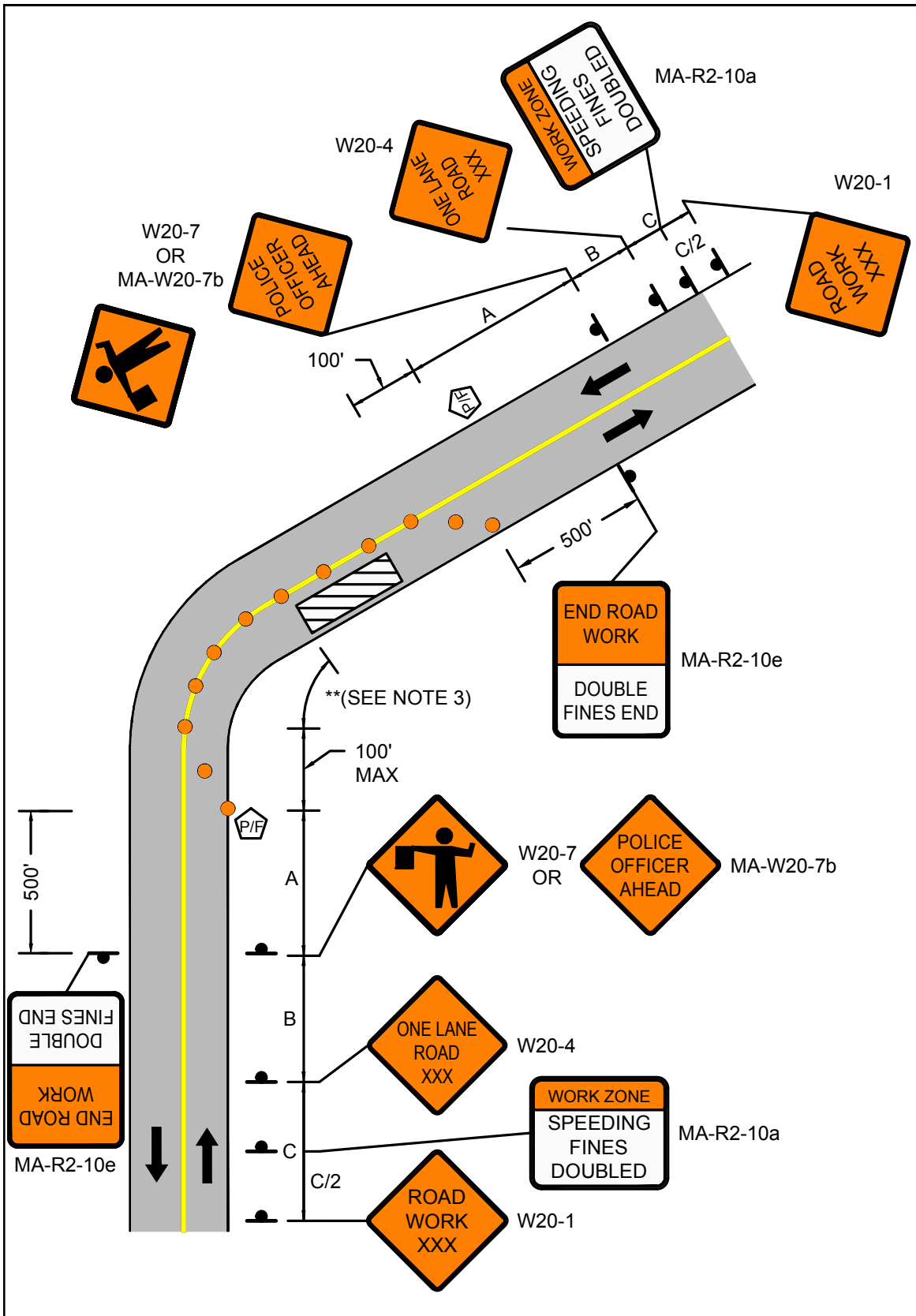

 <p>PAGE 19</p>	<p>Work Zone Safety Standard Details and Drawings</p>	<p>FIGURE 6 STATIONARY OPERATIONS TWO LANE UNDIVIDED ROADWAY HALF OF ROADWAY CLOSED WORK NEAR CURVE</p>
--	---	---



PAGE 20

Work Zone Safety  
Standard Details  
and Drawings

STATIONARY OPERATIONS  
TWO LANE UNDIVIDED ROADWAY  
HALF OF ROADWAY CLOSED

POSTED SPEED LIMIT (MPH)	SPACING FOR ADVANCE WARNING SIGNS (FT) (A,B,C)	CHANNELIZATION DEVICES (DRUMS OR CONES)			
		TRAVEL LANE CLOSURE LENGTH (L) (FT)	BUFFER ZONE LENGTH (FT)	DEVICE SPACING (FT)	MIN # OF DEVICES*
25-40	500 / 500 / 500	50	100	20	30
45-55	500 / 1000 / 1000	100	150	40	20









\* NUMBER OF DEVICES BASED ON 400 FT WORK ZONE.

POSTED REGULATORY OR WORK ZONE SPEED	SEPARATION BETWEEN RUMBLE STRIPS
36-mph to 55-mph	15-feet
35-mph and under	10-feet

NOTES

1. IF POLICE DETAIL/UNIFORMED FLAGGER SUPPORT IS REQUIRED, PROVIDE TWO UNITS.
2. MA-R2-10a LOCATED AT C/2.
3. \*\* OPTIONAL AT THE ENGINEER'S DISCRETION.
4. \*\*\* SHALL BE DEPLOYED IF RUMBLE STRIPS ARE PRESENT.

LEGEND

-  WORK ZONE
-  CHANNELIZATION DEVICE
-  FLASHING ARROW BOARD
-  PORTABLE CHANGEABLE MESSAGE SIGN
-  TRUCK MOUNTED ATTENUATOR
-  RADAR SPEED FEEDBACK BOARD
-  POLICE DETAIL OR UNIFORMED FLAGGER
-  TEMPORARY PORTABLE RUMBLE STRIP
-  TYPE III BARRICADE

NOT TO SCALE

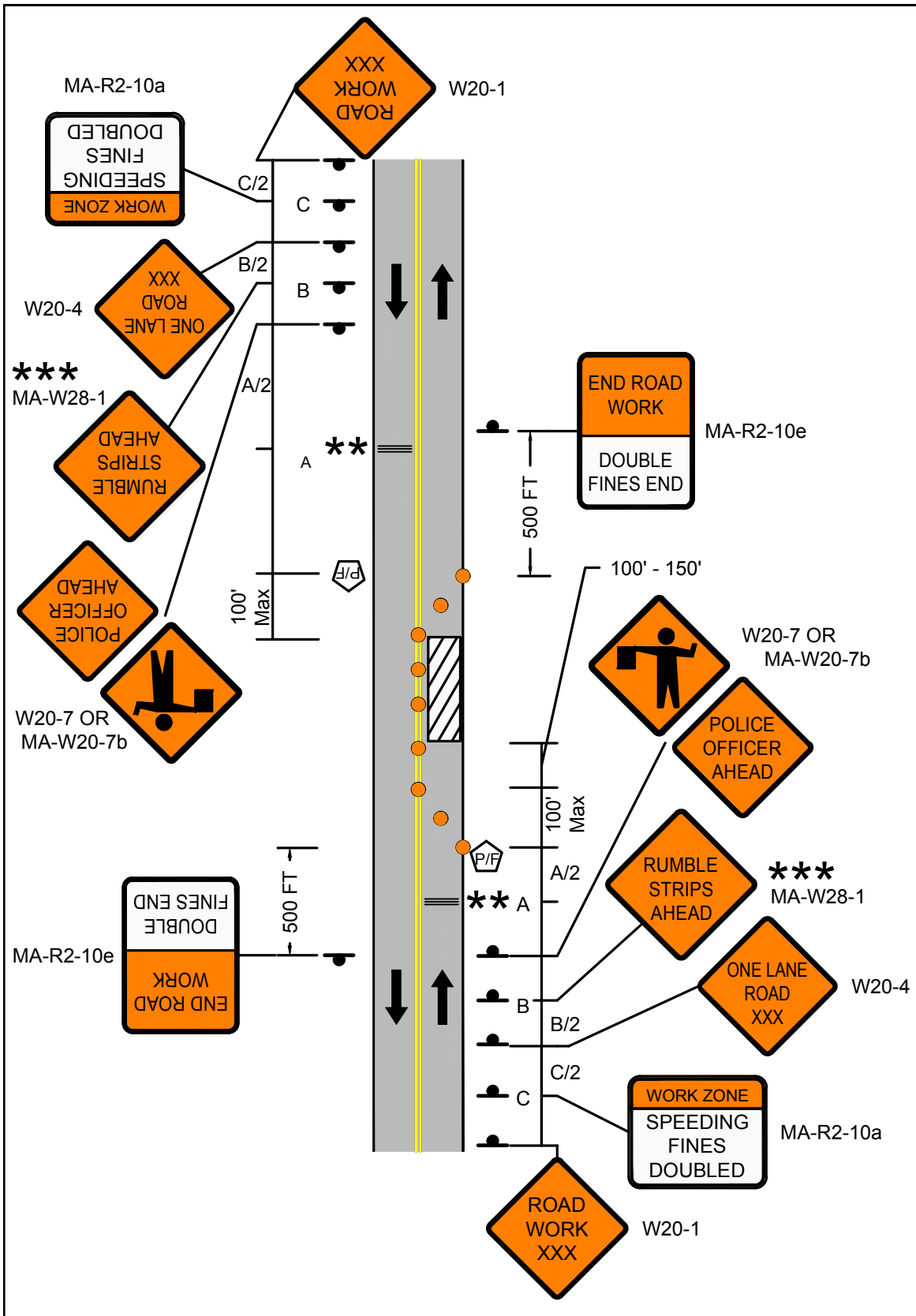

 <p>PAGE 21</p>	<p>Work Zone Safety Standard Details and Drawings</p>	<p>FIGURE 7 STATIONARY OPERATIONS TWO LANE UNDIVIDED ROADWAY HALF OF ROADWAY CLOSED</p>
--	---	---



PAGE 22

Work Zone Safety  
Standard Details  
and Drawings

STATIONARY OPERATIONS  
TWO LANE UNDIVIDED ROADWAY  
SHOULDER CLOSED









POSTED SPEED LIMIT (MPH)	SPACING FOR ADVANCE WARNING SIGNS (FT) (A,B,C)	CHANNELIZATION DEVICES (DRUMS OR CONES)			
		SHOULDER TAPER LENGTH (L/3) (FT)	BUFFER ZONE LENGTH (FT)	DEVICE SPACING (FT)	MIN # OF DEVICES*
25-40	500 / 500 / 500	110	305	20	45
45-55	500 / 1000 / 1000	220	495	40	30
60-65	1000 / 1600 / 2600	260	645	40	35

\* NUMBER OF DEVICES BASED ON 400 FT WORK ZONE.

NOTES

1. MA-R2-10a at C/2 and A/2.

LEGEND

-  WORK ZONE
-  CHANNELIZATION DEVICE
-  FLASHING ARROW BOARD
-  PORTABLE CHANGEABLE MESSAGE SIGN
-  TRUCK MOUNTED ATTENUATOR
-  RADAR SPEED FEEDBACK BOARD
-  POLICE DETAIL OR UNIFORMED FLAGGER
-  TEMPORARY PORTABLE RUMBLE STRIP
-  TYPE III BARRICADE

NOT TO SCALE



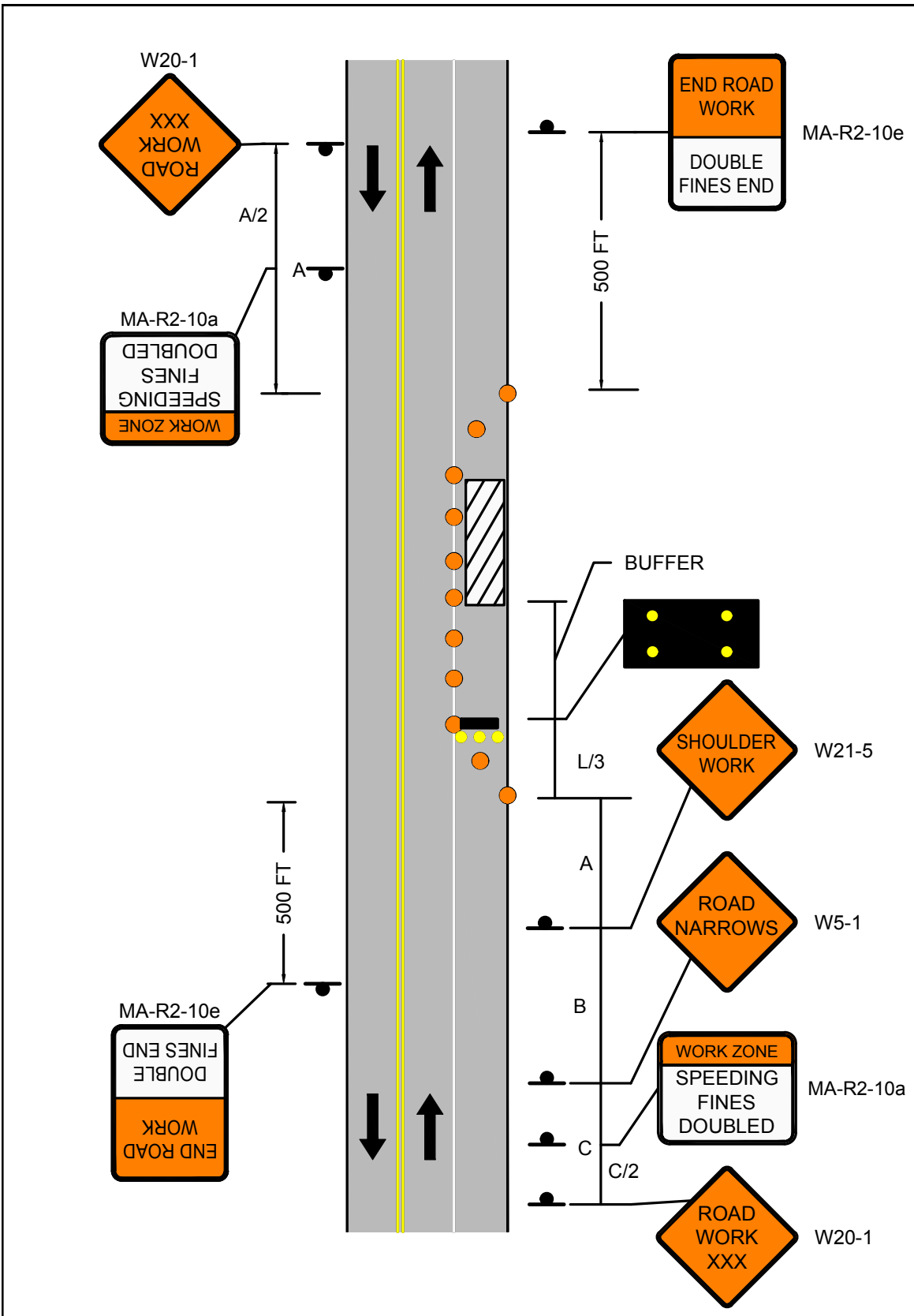

 <p>PAGE 23</p>	<p>Work Zone Safety Standard Details and Drawings</p>	<p>FIGURE 8 STATIONARY OPERATIONS TWO LANE UNDIVIDED ROADWAY SHOULDER CLOSED</p>
--	---	--



PAGE 24

Work Zone Safety  
Standard Details  
and Drawings

STATIONARY OPERATIONS  
TWO LANE UNDIVIDED ROADWAY  
WITH TRAVERSABLE SHOULDER  
HALF OF ROADWAY CLOSED  
MAINTAIN TWO-WAY TRAFFIC

POSTED SPEED LIMIT (MPH)	CHANNELIZATION DEVICES (DRUMS OR CONES)				
	SHOULDER TAPER LENGTH (L/3) (FT)	TRAVEL LANE SHIFT LENGTH (L/2) (FT)	BUFFER ZONE LENGTH (FT)	DEVICE SPACING (FT)	MIN # OF DEVICES*
25-40	110	160	305	20	125
45-55	220	330	495	40	100
60-65	260	390	645	40	115









\* NUMBER OF DEVICES BASED ON 400 FT WORK ZONE.

POSTED SPEED LIMIT (MPH)	SPACING FOR ADVANCE WARNING SIGNS (FT) (A,B,C)
25-40	500 / 500 / 500
45-55	500 / 1000 / 1000
60-65	1000 / 1600 / 2600

**NOTES**

1. MA-R2-10a LOCATED AT C/2.

**LEGEND**

-  WORK ZONE
-  CHANNELIZATION DEVICE
-  FLASHING ARROW BOARD
-  PORTABLE CHANGEABLE MESSAGE SIGN
-  TRUCK MOUNTED ATTENUATOR
-  RADAR SPEED FEEDBACK BOARD
-  POLICE DETAIL OR UNIFORMED FLAGGER
-  TEMPORARY PORTABLE RUMBLE STRIP
-  TYPE III BARRICADE

NOT TO SCALE

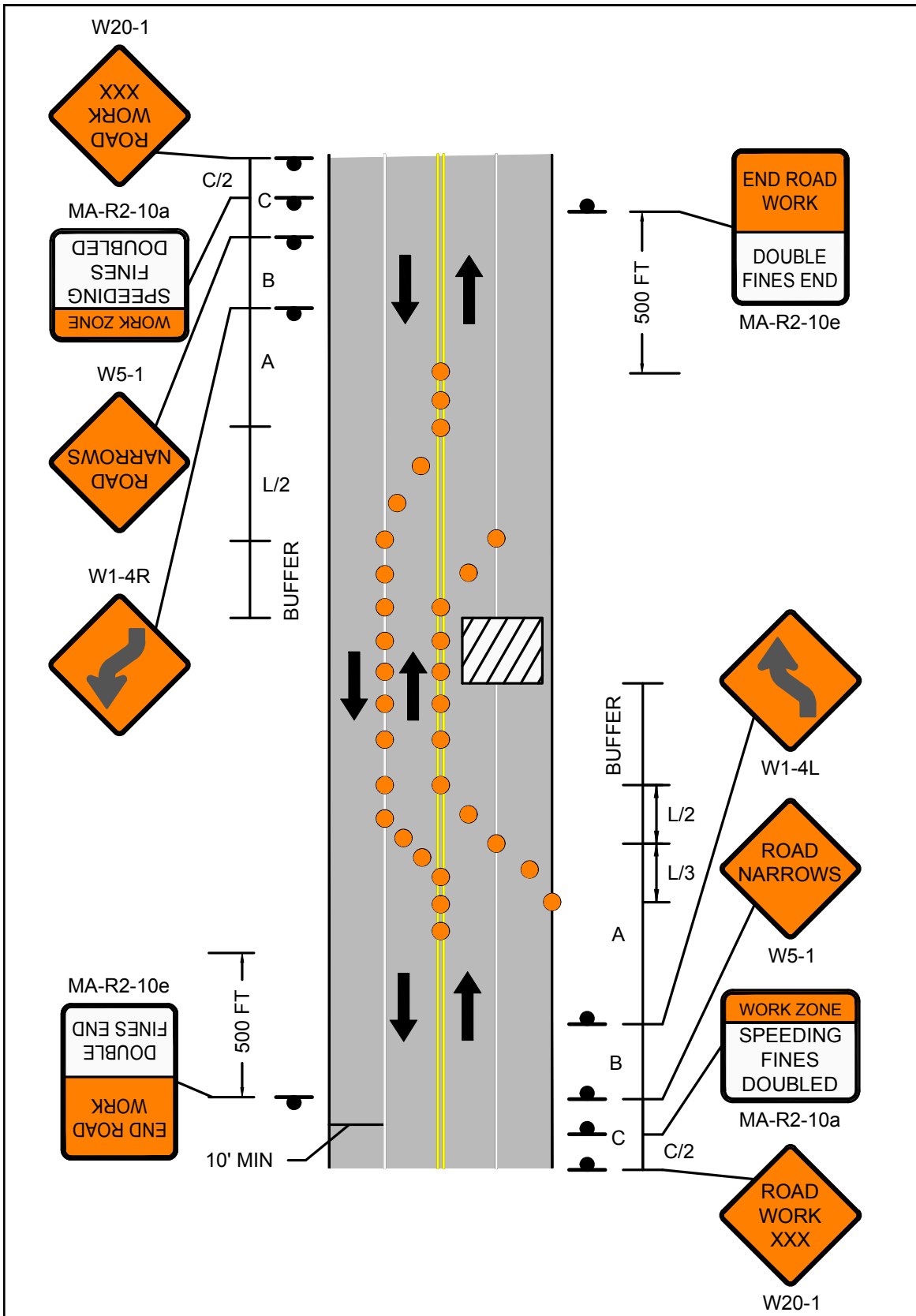

FIGURE 9  
 STATIONARY OPERATIONS  
 TWO LANE UNDIVIDED ROADWAY  
 WITH TRAVERSABLE SHOULDER  
 HALF OF ROADWAY CLOSED  
 MAINTAIN TWO-WAY TRAFFIC





PAGE 26

Work Zone Safety  
Standard Details  
and Drawings

STATIONARY OPERATIONS  
FOUR LANE UNDIVIDED ROADWAY  
RIGHT LANE CLOSED

POSTED SPEED LIMIT (MPH)	CHANNELATION DEVICES (DRUMS OR CONES)				
	SHOULDER TAPER LENGTH (L/3) (FT)	TRAVEL LANE CLOSURE LENGTH (L) (FT)	BUFFER ZONE LENGTH (FT)	DEVICE SPACING (FT)	MIN # OF DEVICES*
25-40	110	320	305	20	60
45-55	220	660	495	40	50
60-65	260	780	645	40	55









\* NUMBER OF DEVICES BASED ON 400 FT WORK ZONE.

POSTED SPEED LIMIT (MPH)	SPACING FOR ADVANCE WARNING SIGNS (FT) (A,B,C)
25-40	500 / 500 / 500
45-55	500 / 1000 / 1000
60-65	1000 / 1600 / 2600

**NOTES**

1. MA-R2-10a LOCATED AT A/2 AND C/2.
2. \*\*OPTIONAL AT THE ENGINEER'S DISCRETION.

**LEGEND**

-  WORK ZONE
-  CHANNELIZATION DEVICE
-  FLASHING ARROW BOARD
-  PORTABLE CHANGEABLE MESSAGE SIGN
-  TRUCK MOUNTED ATTENUATOR
-  RADAR SPEED FEEDBACK BOARD
-  POLICE DETAIL OR UNIFORMED FLAGGER
-  TEMPORARY PORTABLE RUMBLE STRIP
-  TYPE III BARRICADE

NOT TO SCALE

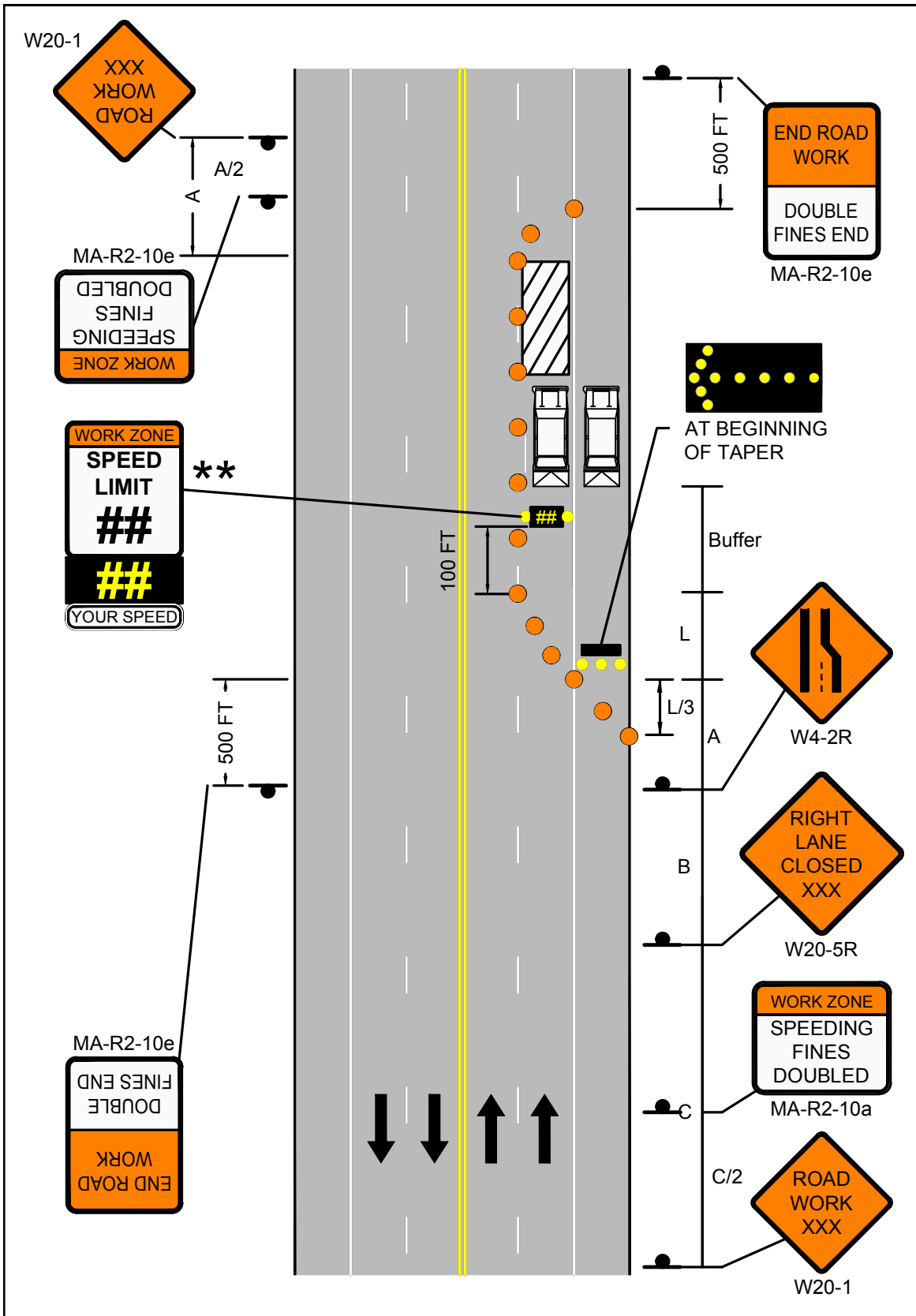

 <p>PAGE 27</p>	<p>Work Zone Safety Standard Details and Drawings</p>	<p>FIGURE 10 STATIONARY OPERATIONS FOUR LANE UNDIVIDED ROADWAY RIGHT LANE CLOSED</p>
--	---	--



PAGE 28

Work Zone Safety  
Standard Details  
and Drawings

STATIONARY OPERATIONS  
FOUR LANE UNDIVIDED ROADWAY  
LEFT LANE CLOSED









POSTED SPEED LIMIT (MPH)	SPACING FOR ADVANCE WARNING SIGNS (FT) (A,B,C)	CHANNELIZATION DEVICES (DRUMS OR CONES)			
		TRAVEL LANE CLOSURE LENGTH (L) (FT)	BUFFER ZONE LENGTH (FT)	DEVICE SPACING (FT)	MIN # OF DEVICES*
25-40	500 / 500 / 500	320	305	20	105
45-55	500 / 1000 / 1000	660	495	40	80
60-65	1000 / 1600 / 2600	780	645	40	100

\* NUMBER OF DEVICES BASED ON 400 FT WORK ZONE.

**NOTES**

1. MA-R2-10a LOCATED AT A/2 AND C/2.
2. \*\*OPTIONAL AT THE ENGINEER'S DISCRETION. 2' OFFSET FROM EDGE OF TRAVEL LANE TO RADAR SPEED FEEDBACK BOARD IS REQUIRED. BOARD MAY BE MOVED FULLY OR PARTIALLY OFF PAVED SHOULDER, IF REQUIRED.

**LEGEND**

-  WORK ZONE
-  CHANNELIZATION DEVICE
-  FLASHING ARROW BOARD
-  PORTABLE CHANGEABLE MESSAGE SIGN
-  TRUCK MOUNTED ATTENUATOR
-  RADAR SPEED FEEDBACK BOARD
-  POLICE DETAIL OR UNIFORMED FLAGGER
-  TEMPORARY PORTABLE RUMBLE STRIP
-  TYPE III BARRICADE

NOT TO SCALE

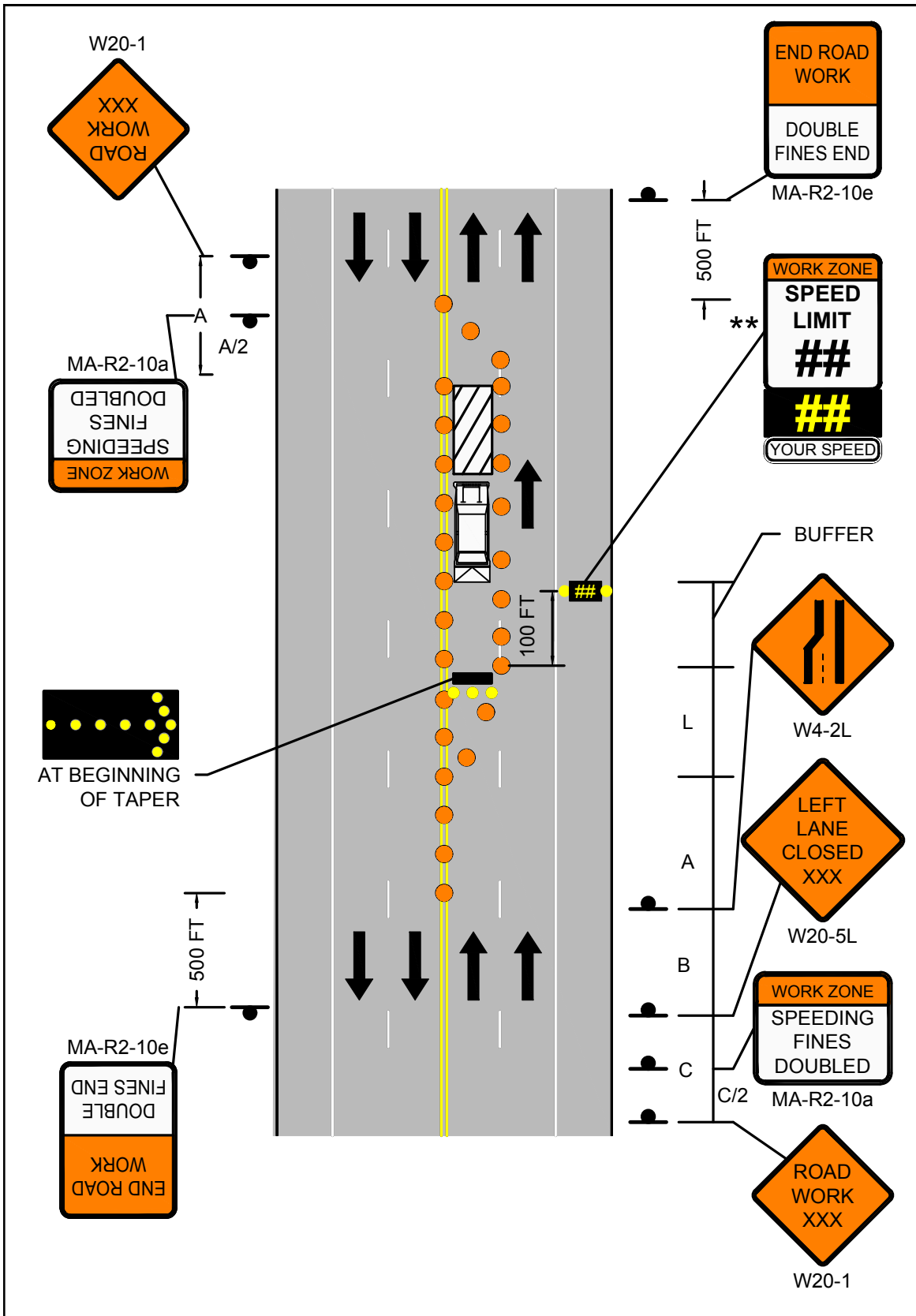

 <p>PAGE 29</p>	<p>Work Zone Safety Standard Details and Drawings</p>	<p>FIGURE 11 STATIONARY OPERATIONS FOUR LANE UNDIVIDED ROADWAY LEFT LANE CLOSED</p>
--	---	---

 <p>Massachusetts Department of Transportation Highway Division</p> <p>PAGE 30</p>	<p>Work Zone Safety Standard Details and Drawings</p>	<p>STATIONARY OPERATIONS FOUR LANE UNDIVIDED ROADWAY HALF OF ROADWAY CLOSED</p>
---	---	---

POSTED SPEED LIMIT (MPH)	CHANNELIZATION DEVICES (DRUMS OR CONES)					
	SHOULDER TAPER LENGTH (L/3) (FT)	TRAVEL LANE CLOSURE LENGTH (L) (FT)	TRAVEL LANE SHIFT LENGTH (L/2) (FT)	BUFFER ZONE LENGTH (FT)	DEVICE SPACING (FT)	MIN # OF DEVICES*
25-40	110	320	160	305	20	140
45-55	220	660	330	495	40	120
60-65	260	780	390	645	40	140









\* NUMBER OF DEVICES BASED ON 400 FT WORK ZONE.

POSTED SPEED LIMIT (MPH)	SPACING FOR ADVANCE WARNING SIGNS (FT) (A,B,C)
25-40	500 / 500 / 500
45-55	500 / 1000 / 1000
60-65	1000 / 1600 / 2600

**NOTES**

1. MA-R2-10a LOCATED AT C/2.
2. \*\*OPTIONAL AT THE ENGINEER'S DISCRETION.
3. W1-4L SHALL BE PLACED AT THE MIDDLE OF THE TANGENT.

**LEGEND**

-  WORK ZONE
-  CHANNELIZATION DEVICE
-  FLASHING ARROW BOARD
-  PORTABLE CHANGEABLE MESSAGE SIGN
-  TRUCK MOUNTED ATTENUATOR
-  RADAR SPEED FEEDBACK BOARD
-  POLICE DETAIL OR UNIFORMED FLAGGER
-  TEMPORARY PORTABLE RUMBLE STRIP
-  TYPE III BARRICADE

NOT TO SCALE



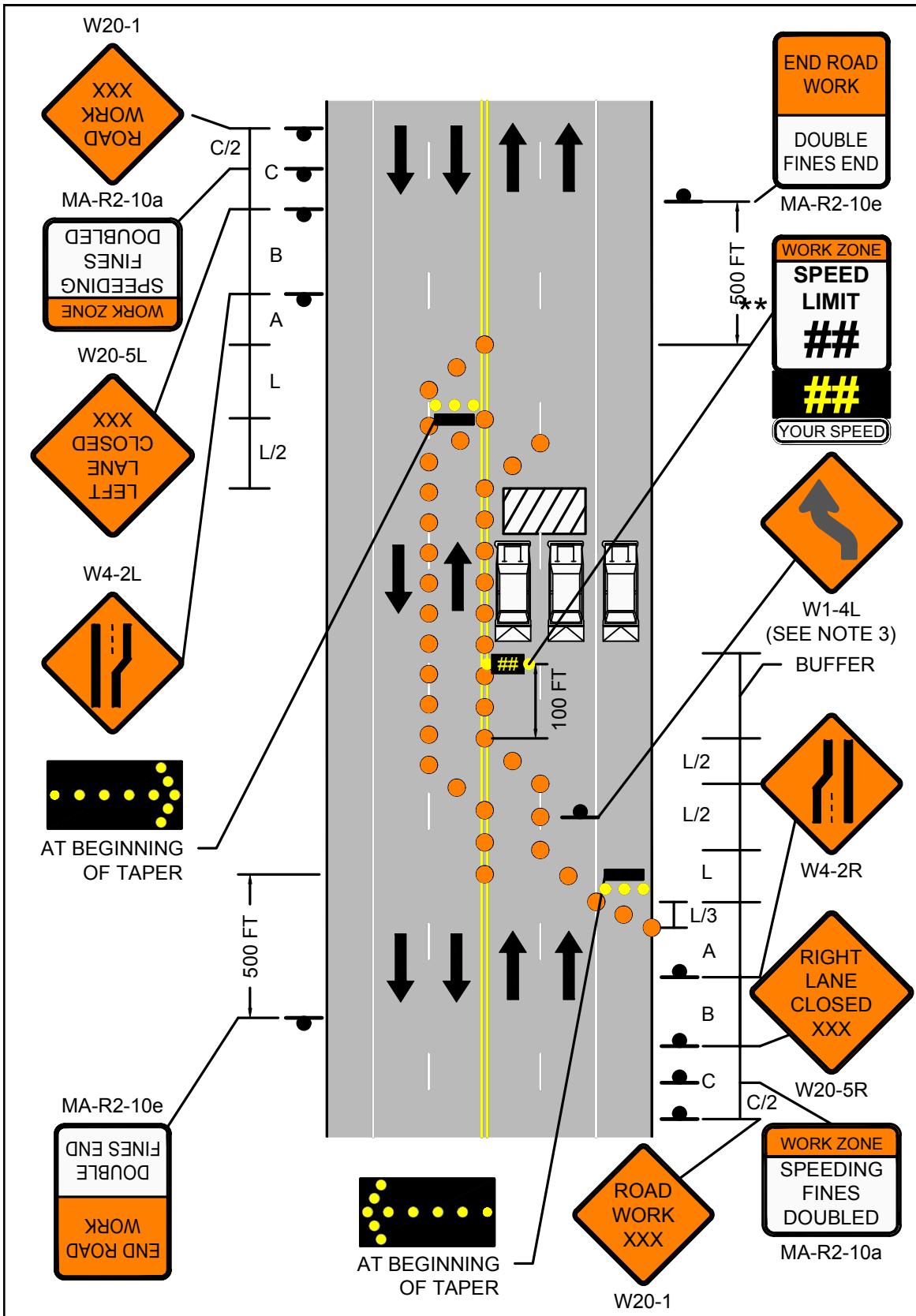

**FIGURE 12**  
**STATIONARY OPERATIONS**  
**FOUR LANE UNDIVIDED ROADWAY**  
**HALF OF ROADWAY CLOSED**





PAGE 32

Work Zone Safety  
Standard Details  
and Drawings

STATIONARY OPERATIONS  
MULTILANE DIVIDED ROADWAY  
RIGHT LANE CLOSED

POSTED SPEED LIMIT (MPH)	CHANNELIZATION DEVICES (DRUMS OR CONES)				
	SHOULDER TAPER LENGTH (L/3) (FT)	TRAVEL LANE CLOSURE LENGTH (L) (FT)	BUFFER ZONE LENGTH (FT)	DEVICE SPACING (FT)	MIN # OF DEVICES*
25-40	110	320	305	20	60
45-55	220	660	495	40	50
60-65	260	780	645	40	55









\* NUMBER OF DEVICES BASED ON 400 FT WORK ZONE.

POSTED SPEED LIMIT (MPH)	SPACING FOR ADVANCE WARNING SIGNS (FT) (A,B,C)
25-40	500 / 500 / 500
45-55	500 / 1000 / 1000
60-65	1000 / 1600 / 2600

**NOTES**

1. MA-R2-10a LOCATED AT C/2.
2. \*\*OPTIONAL AT THE ENGINEER'S DISCRETION.

**LEGEND**

-  WORK ZONE
-  CHANNELIZATION DEVICE
-  FLASHING ARROW BOARD
-  PORTABLE CHANGEABLE MESSAGE SIGN
-  TRUCK MOUNTED ATTENUATOR
-  RADAR SPEED FEEDBACK BOARD
-  POLICE DETAIL OR UNIFORMED FLAGGER
-  TEMPORARY PORTABLE RUMBLE STRIP
-  TYPE III BARRICADE

NOT TO SCALE

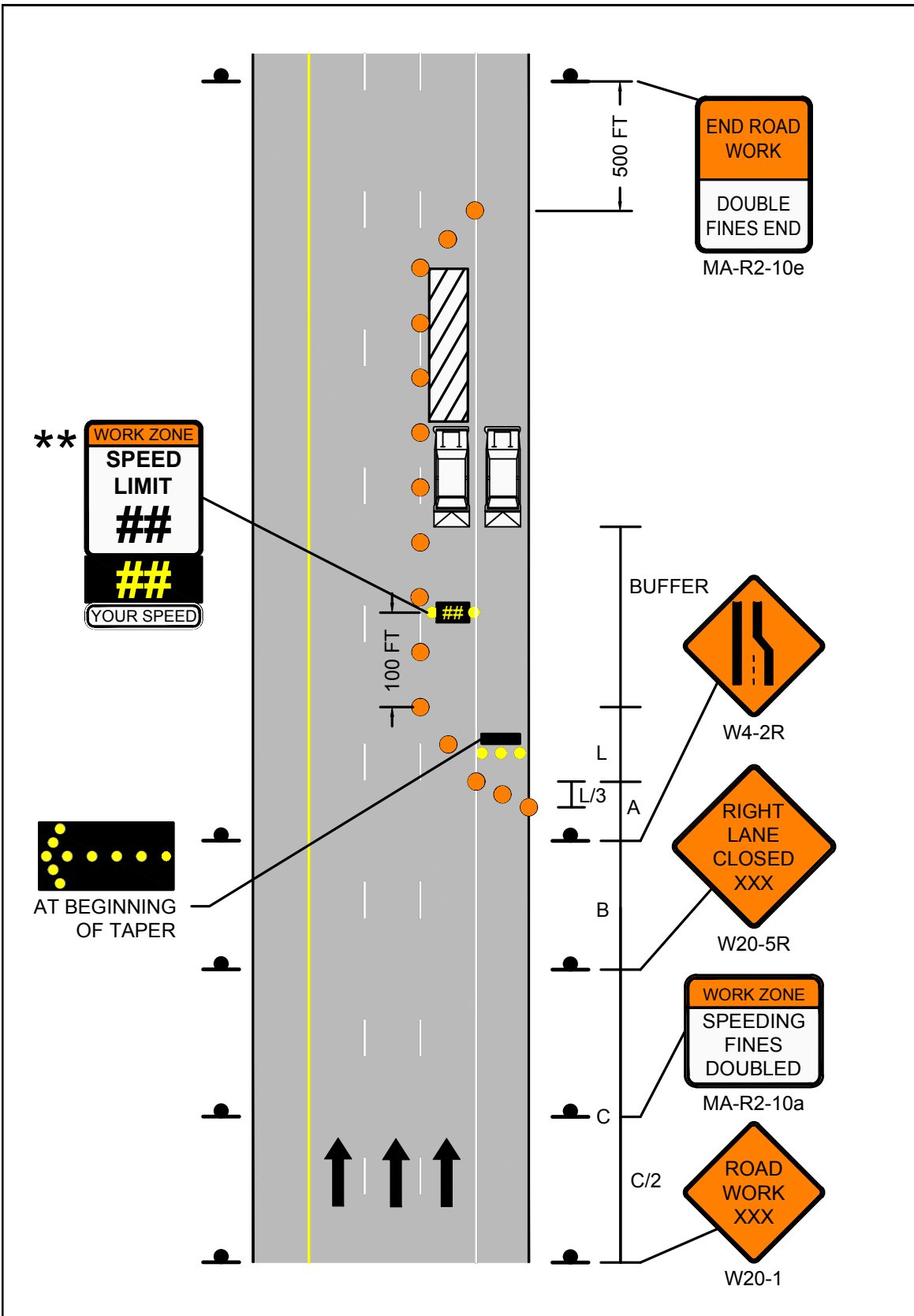

 <p>PAGE 33</p>	<p>Work Zone Safety Standard Details and Drawings</p>	<p>FIGURE 13 STATIONARY OPERATIONS MULTILANE DIVIDED ROADWAY RIGHT LANE CLOSED</p>
--	---	--



PAGE 34

Work Zone Safety  
Standard Details  
and Drawings

STATIONARY OPERATIONS  
MULTILANE DIVIDED ROADWAY  
LEFT LANE CLOSED

POSTED SPEED LIMIT (MPH)	CHANNELIZATION DEVICES (DRUMS OR CONES)				
	SHOULDER TAPER LENGTH (L/3) (FT)	TRAVEL LANE CLOSURE LENGTH (L) (FT)	BUFFER ZONE LENGTH (FT)	DEVICE SPACING (FT)	MIN # OF DEVICES*
25-40	110	320	305	20	60
45-55	220	660	495	40	50
60-65	260	780	645	40	55









\* NUMBER OF DEVICES BASED ON 400 FT WORK ZONE.

POSTED SPEED LIMIT (MPH)	SPACING FOR ADVANCE WARNING SIGNS (FT) (A,B,C)
25-40	500 / 500 / 500
45-55	500 / 1000 / 1000
60-65	1000 / 1600 / 2600

**NOTES**

1. MA-R2-10a LOCATED AT C/2.
2. \*\*OPTIONAL AT THE ENGINEER'S DISCRETION.

**LEGEND**

-  WORK ZONE
-  CHANNELIZATION DEVICE
-  FLASHING ARROW BOARD
-  PORTABLE CHANGEABLE MESSAGE SIGN
-  TRUCK MOUNTED ATTENUATOR
-  RADAR SPEED FEEDBACK BOARD
-  POLICE DETAIL OR UNIFORMED FLAGGER
-  TEMPORARY PORTABLE RUMBLE STRIP
-  TYPE III BARRICADE

NOT TO SCALE

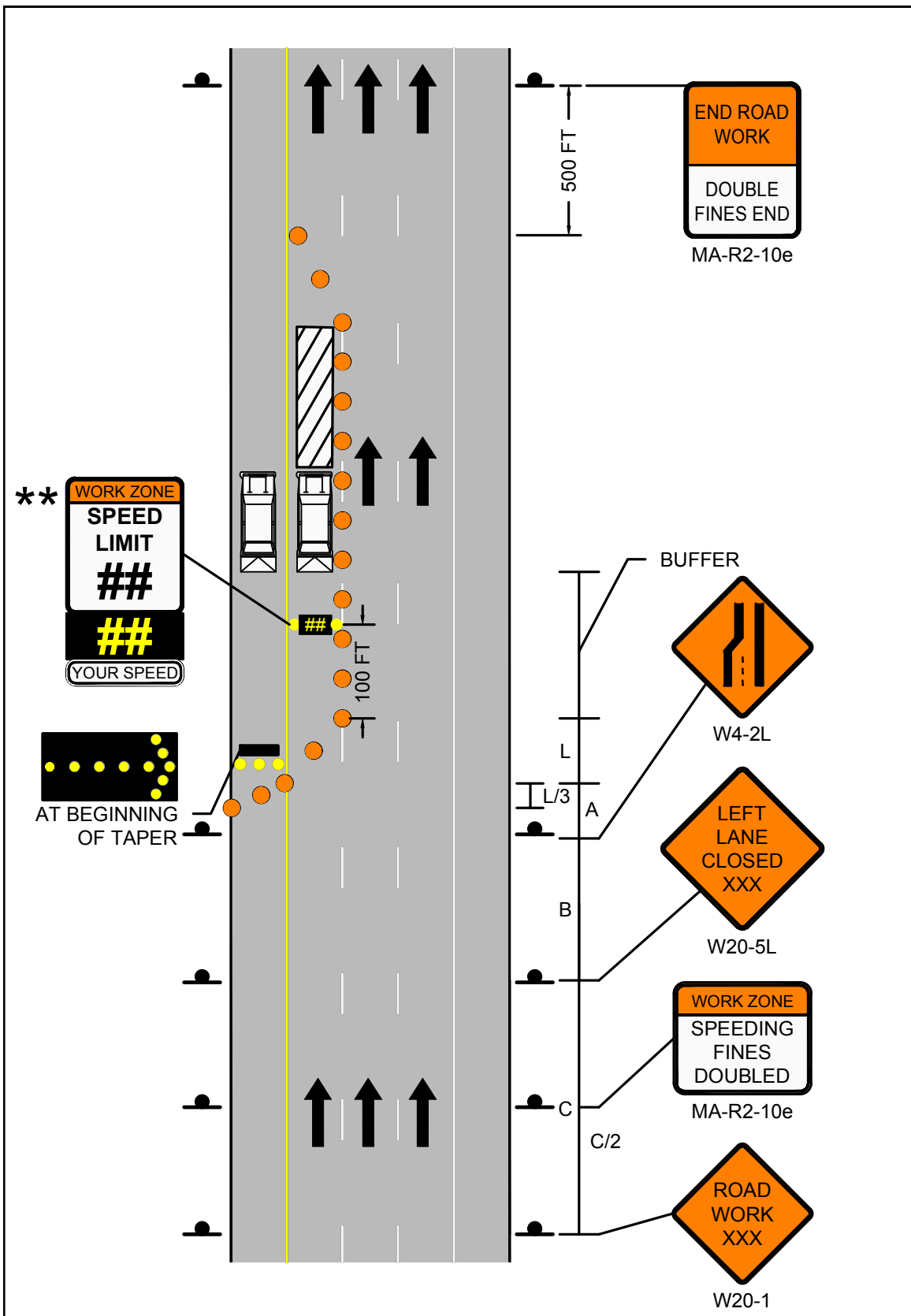

 PAGE 36	Work Zone Safety Standard Details and Drawings	STATIONARY OPERATIONS MULTILANE DIVIDED ROADWAY CENTER LANE OR RIGHT/CENTER LANES CLOSED
--	--	---

POSTED SPEED LIMIT (MPH)	CHANNELIZATION DEVICES (DRUMS OR CONES)					
	SHOULDER TAPER LENGTH (L/3) (FT)	TRAVEL LANE CLOSURE LENGTH (L) (FT)	TANGENT LENGTH BETWEEN TAPERS T (FT)	BUFFER ZONE LENGTH (FT)	DEVICE SPACING (FT)	MIN # OF DEVICES*
25-40	110	320	640	305	20	110
45-55	220	660	1320	495	40	100
60-65	260	780	1560	645	40	115









\* NUMBER OF DEVICES BASED ON 400 FT WORK ZONE.

POSTED SPEED LIMIT (MPH)	SPACING FOR ADVANCE WARNING SIGNS (FT) (A,B,C)
25-40	500 / 500 / 500
45-55	500 / 1000 / 1000
60-65	1000 / 1600 / 2600

**NOTES**

1. MA-R2-10a LOCATED AT C/2.
2. \*\*\*OPTIONAL AT THE ENGINEER'S DISCRETION.
3. \*\*\*THIS SET OF SIGNS SHALL BE LOCATED AT T/2.

**LEGEND**

-  WORK ZONE
-  CHANNELIZATION DEVICE
-  FLASHING ARROW BOARD
-  PORTABLE CHANGEABLE MESSAGE SIGN
-  TRUCK MOUNTED ATTENUATOR
-  RADAR SPEED FEEDBACK BOARD
-  POLICE DETAIL OR UNIFORMED FLAGGER
-  TEMPORARY PORTABLE RUMBLE STRIP
-  TYPE III BARRICADE

NOT TO SCALE

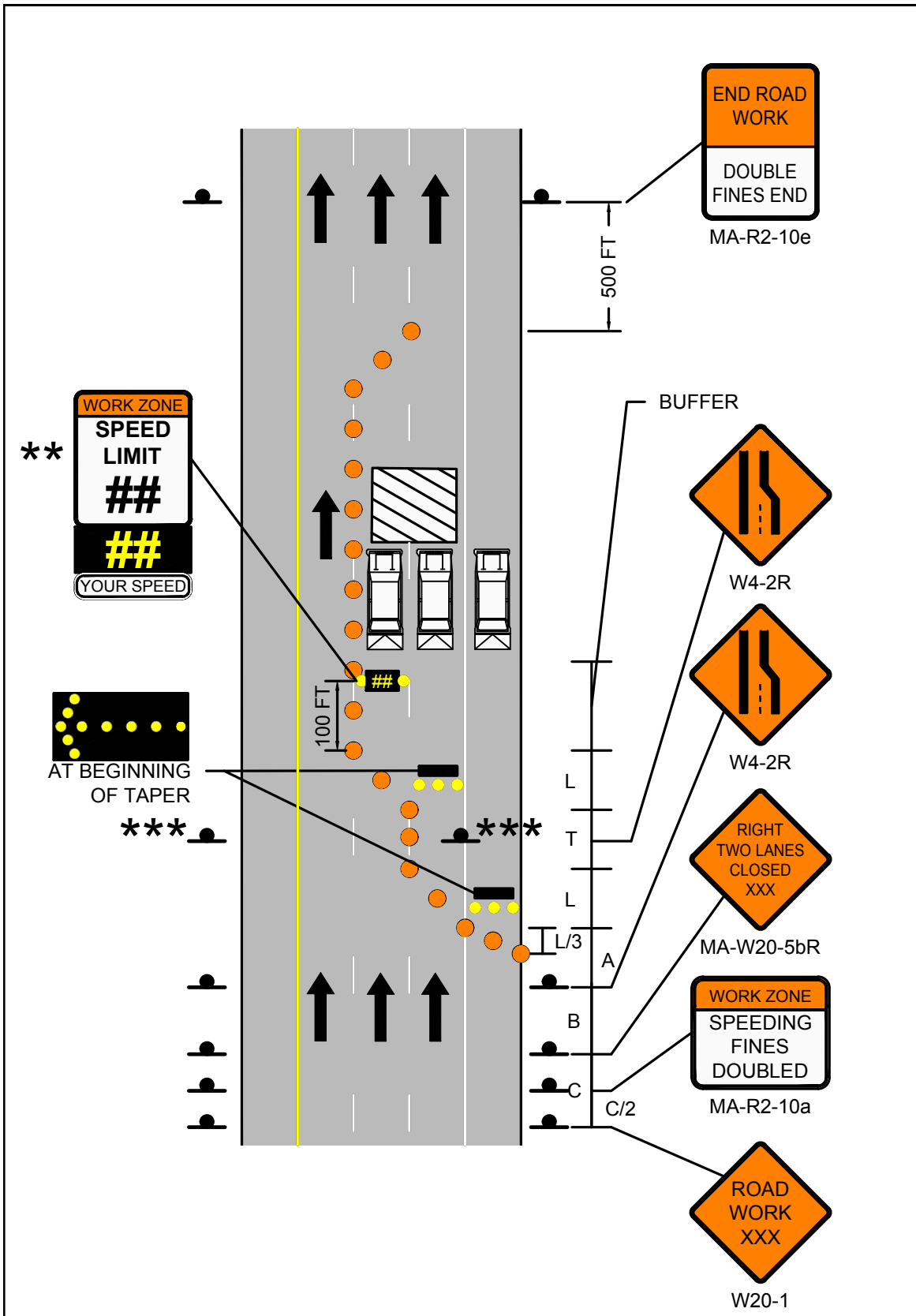

 <p>Massachusetts Department of Transportation Highway Division</p> <p>PAGE 37</p>	<p>Work Zone Safety Standard Details and Drawings</p>	<p>FIGURE 15 STATIONARY OPERATIONS MULTILANE DIVIDED ROADWAY CENTER LANE OR RIGHT/CENTER LANES CLOSED</p>
---	---	---

 <p>Massachusetts Department of Transportation Highway Division</p> <p>PAGE 38</p>	<p>Work Zone Safety Standard Details and Drawings</p>	<p>STATIONARY OPERATIONS MULTILANE DIVIDED ROADWAY CENTER LANE OR LEFT/CENTER LANES CLOSED</p>
---	---	--

POSTED SPEED LIMIT (MPH)	CHANNELIZATION DEVICES (DRUMS OR CONES)					
	SHOULDER TAPER LENGTH (L/3) (FT)	TRAVEL LANE CLOSURE LENGTH (L) (FT)	TANGENT LENGTH BETWEEN TAPERS T (FT)	BUFFER ZONE LENGTH (FT)	DEVICE SPACING (FT)	MIN # OF DEVICES*
25-40	110	320	640	305	20	110
45-55	220	660	1320	495	40	100
60-65	260	780	1560	645	40	115









\* NUMBER OF DEVICES BASED ON 400 FT WORK ZONE.

POSTED SPEED LIMIT (MPH)	SPACING FOR ADVANCE WARNING SIGNS (FT) (A,B,C)
25-40	500 / 500 / 500
45-55	500 / 1000 / 1000
60-65	1000 / 1600 / 2600

**NOTES**

1. MA-R2-10a LOCATED AT C/2.
2. \*\*\*OPTIONAL AT THE ENGINEER'S DISCRETION.
3. \*\*\*THIS SET OF SIGNS SHALL BE LOCATED AT T/2.

**LEGEND**

-  WORK ZONE
-  CHANNELIZATION DEVICE
-  FLASHING ARROW BOARD
-  PORTABLE CHANGEABLE MESSAGE SIGN
-  TRUCK MOUNTED ATTENUATOR
-  RADAR SPEED FEEDBACK BOARD
-  POLICE DETAIL OR UNIFORMED FLAGGER
-  TEMPORARY PORTABLE RUMBLE STRIP
-  TYPE III BARRICADE

NOT TO SCALE



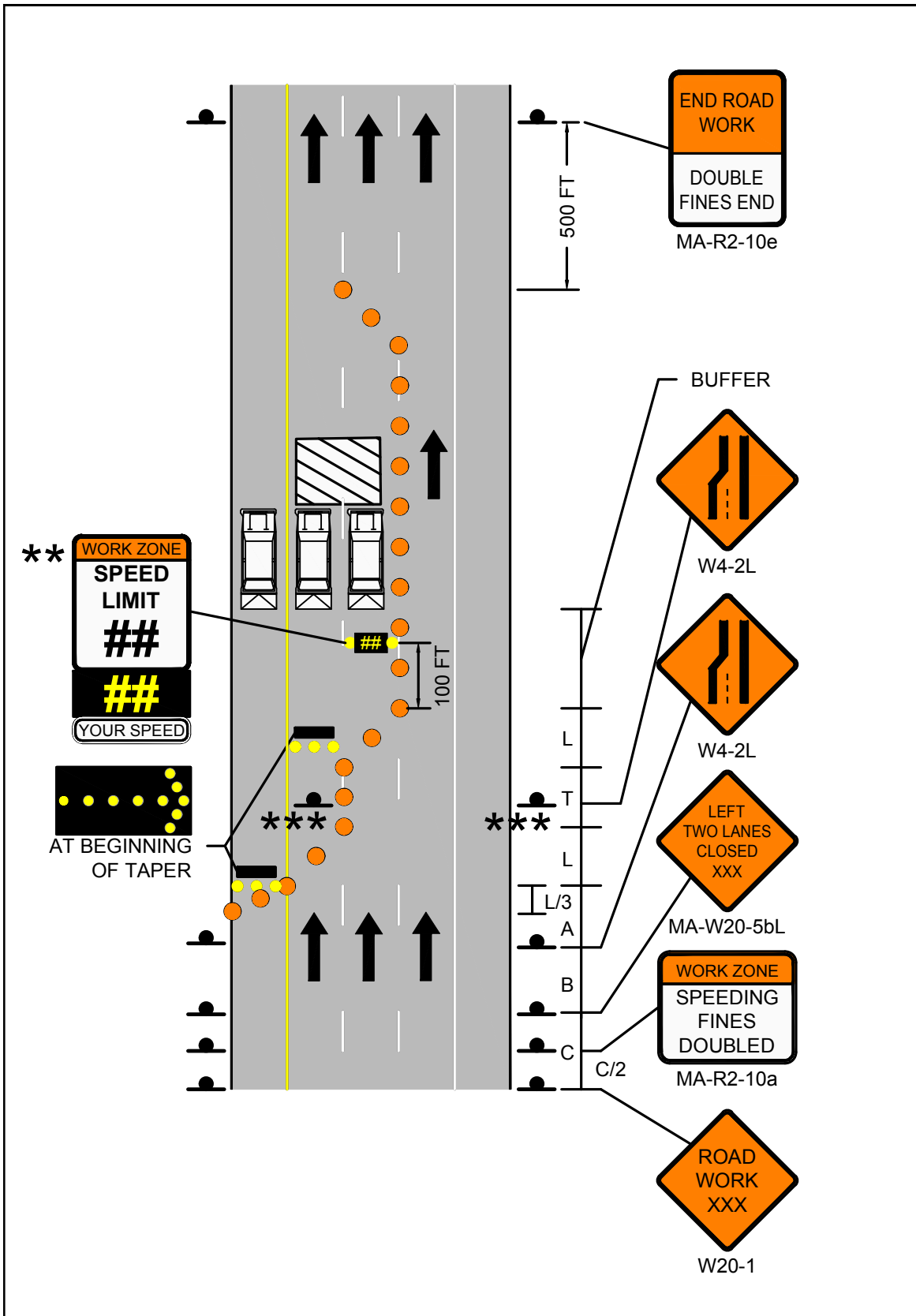

 <p>PAGE 39</p>	<p>Work Zone Safety Standard Details and Drawings</p>	<p>FIGURE 16 STATIONARY OPERATIONS MULTILANE DIVIDED ROADWAY CENTER LANE OR LEFT/CENTER LANES CLOSED</p>
--	---	--



PAGE 40

Work Zone Safety  
Standard Details  
and Drawings

STATIONARY OPERATIONS  
MULTILANE DIVIDED ROADWAY  
RIGHT SIDE OF OFF RAMP CLOSED









POSTED SPEED LIMIT (MPH)	SPACING FOR ADVANCE WARNING SIGNS (FT) (A,B,C)	CHANNELIZATION DEVICES (DRUMS OR CONES)			
		TRAVEL LANE SHIFT LENGTH (L/2) (FT)	BUFFER ZONE LENGTH (FT)	DEVICE SPACING (FT)	MIN # OF DEVICES*
25-40	500 / 500 / 500	160	305	20	45
45-55	500 / 1000 / 1000	330	495	40	35

\* NUMBER OF DEVICES BASED ON 400 FT WORK ZONE.

NOTES

1. MA-R2-10a LOCATED AT C/2.

LEGEND

-  WORK ZONE
-  CHANNELIZATION DEVICE
-  FLASHING ARROW BOARD
-  PORTABLE CHANGEABLE MESSAGE SIGN
-  TRUCK MOUNTED ATTENUATOR
-  RADAR SPEED FEEDBACK BOARD
-  POLICE DETAIL OR UNIFORMED FLAGGER
-  TEMPORARY PORTABLE RUMBLE STRIP
-  TYPE III BARRICADE

NOT TO SCALE

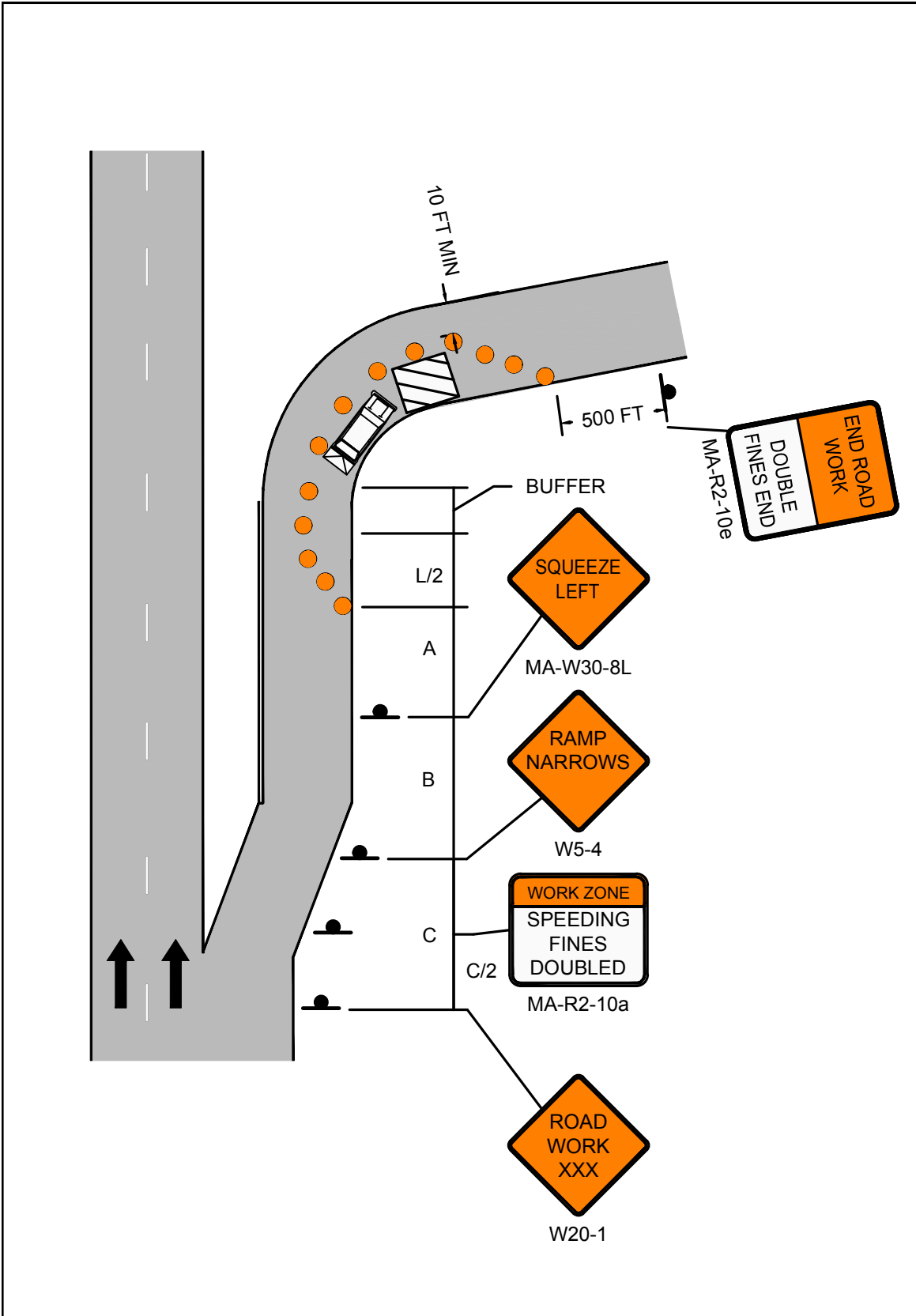

 <p>PAGE 41</p>	<p>Work Zone Safety Standard Details and Drawings</p>	<p>FIGURE 17 STATIONARY OPERATIONS MULTILANE DIVIDED ROADWAY RIGHT SIDE OF OFF RAMP CLOSED</p>
--	---	--



PAGE 42

Work Zone Safety  
Standard Details  
and Drawings

STATIONARY OPERATIONS  
MULTILANE DIVIDED ROADWAY  
LEFT SIDE OF OFF RAMP CLOSED









POSTED SPEED LIMIT (MPH)	SPACING FOR ADVANCE WARNING SIGNS (FT) (A,B,C)	CHANNELIZATION DEVICES (DRUMS OR CONES)			
		TRAVEL LANE SHIFT LENGTH (L/2) (FT)	BUFFER ZONE LENGTH (FT)	DEVICE SPACING (FT)	MIN # OF DEVICES*
25-40	500 / 500 / 500	160	305	20	45
45-55	500 / 1000 / 1000	330	495	40	35

\* NUMBER OF DEVICES BASED ON 400 FT WORK ZONE.

NOTES

1. MA-R2-10a LOCATED AT C/2.

LEGEND

-  WORK ZONE
-  CHANNELIZATION DEVICE
-  FLASHING ARROW BOARD
-  PORTABLE CHANGEABLE MESSAGE SIGN
-  TRUCK MOUNTED ATTENUATOR
-  RADAR SPEED FEEDBACK BOARD
-  POLICE DETAIL OR UNIFORMED FLAGGER
-  TEMPORARY PORTABLE RUMBLE STRIP
-  TYPE III BARRICADE

NOT TO SCALE

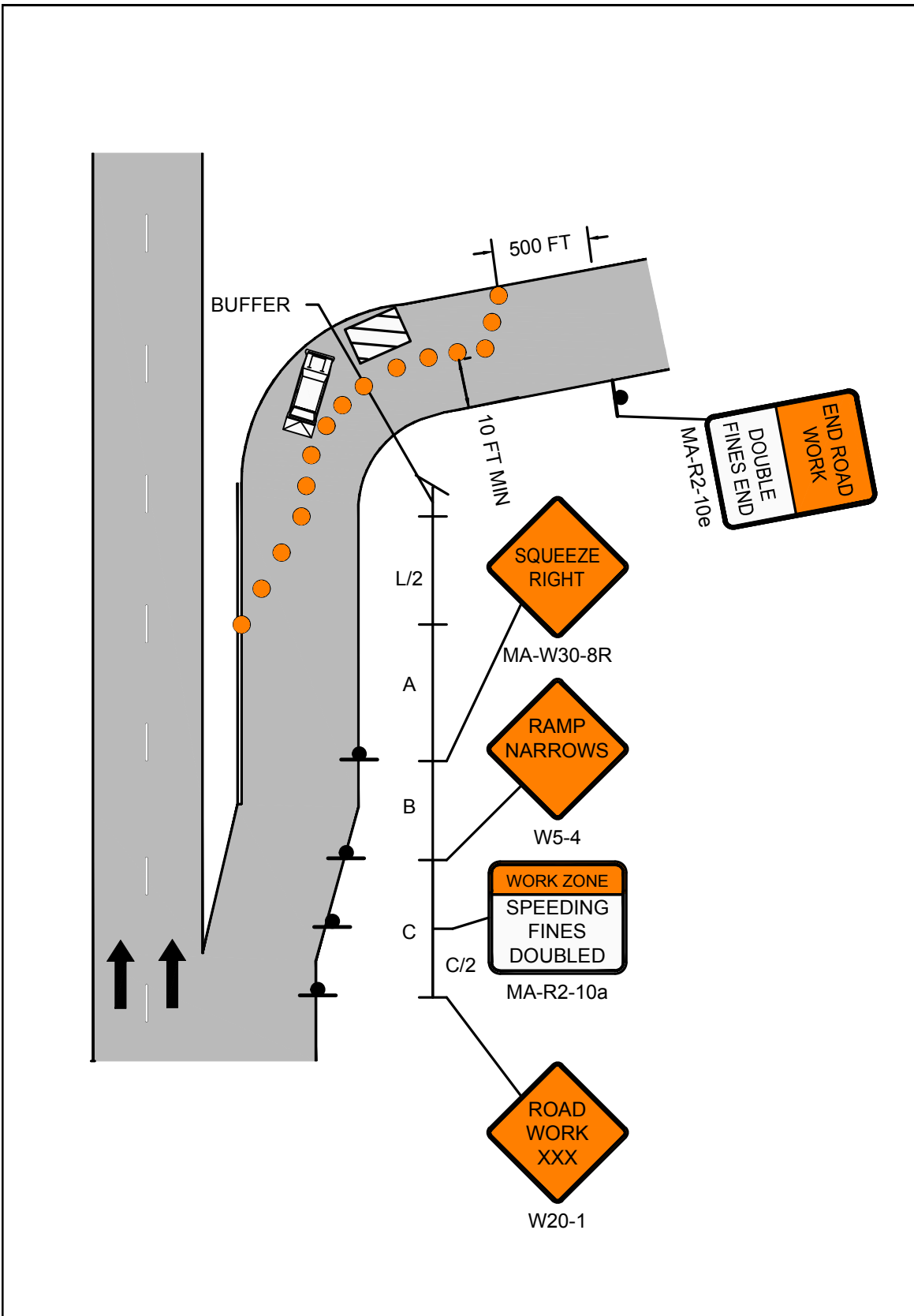

	<p>Work Zone Safety Standard Details and Drawings</p>	<p>FIGURE 18 STATIONARY OPERATIONS MULTILANE DIVIDED ROADWAY LEFT SIDE OF OFF RAMP CLOSED PAGE 43</p>
---	---	---



PAGE 44

Work Zone Safety  
Standard Details  
and Drawings

STATIONARY OPERATIONS  
MULTILANE DIVIDED ROADWAY  
ROADWORK BEYOND ON RAMP

POSTED SPEED LIMIT (MPH)	CHANNELIZATION DEVICES (DRUMS OR CONES)				
	SHOULDER TAPER LENGTH (L/3) (FT)	TRAVEL LANE CLOSURE LENGTH (L) (FT)	BUFFER ZONE LENGTH (FT)	DEVICE SPACING (FT)	MIN # OF DEVICES*
25-40	110	320	305	20	175
45-55	220	660	495	40	135
60-65	260	780	645	40	155









\* NUMBER OF DEVICES BASED ON 400 FT WORK ZONE.

POSTED SPEED LIMIT (MPH)	SPACING FOR ADVANCE WARNING SIGNS (FT) (A,B,C)
25-40	500 / 500 / 500
45-55	500 / 1000 / 1000
60-65	1000 / 1600 / 2600

**NOTES**

1. MA-R2-10a LOCATED AT C/2.

**LEGEND**

-  WORK ZONE
-  CHANNELIZATION DEVICE
-  FLASHING ARROW BOARD
-  PORTABLE CHANGEABLE MESSAGE SIGN
-  TRUCK MOUNTED ATTENUATOR
-  RADAR SPEED FEEDBACK BOARD
-  POLICE DETAIL OR UNIFORMED FLAGGER
-  TEMPORARY PORTABLE RUMBLE STRIP
-  TYPE III BARRICADE

NOT TO SCALE

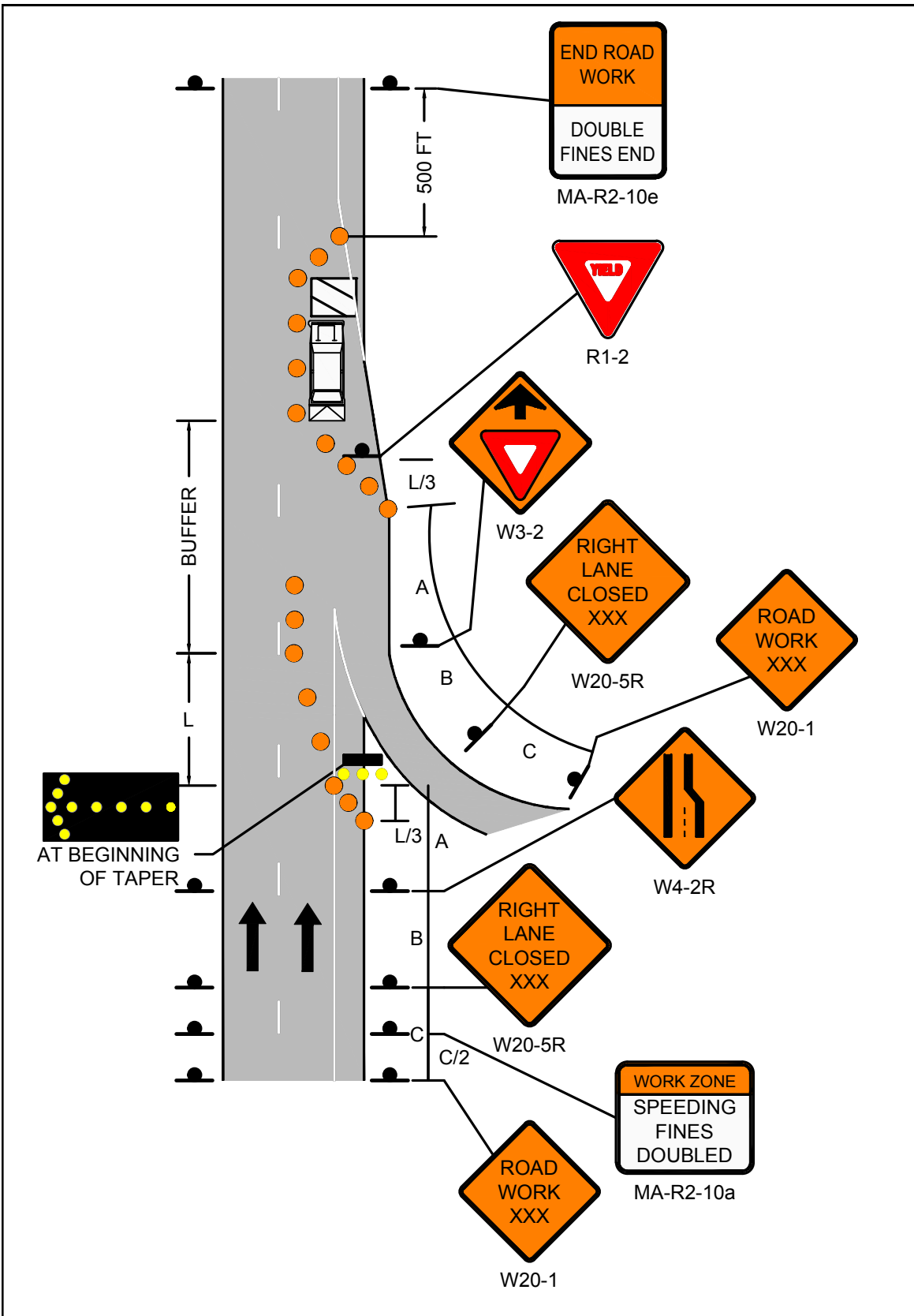

 <p>PAGE 45</p>	<p>Work Zone Safety Standard Details and Drawings</p>	<p>FIGURE 19 STATIONARY OPERATIONS MULTILANE DIVIDED ROADWAY ROADWORK BEYOND ON RAMP</p>
--	---	--

 <p>Massachusetts Department of Transportation Highway Division</p> <p>PAGE 46</p>	<p>Work Zone Safety Standard Details and Drawings</p>	<p>STATIONARY OPERATIONS MULTILANE DIVIDED ROADWAY ROADWORK BEYOND OFF RAMP</p>
---	---	---

POSTED SPEED LIMIT (MPH)	CHANNELIZATION DEVICES (DRUMS OR CONES)					
	SHOULDER TAPER LENGTH (L/3) (FT)	TRAVEL LANE CLOSURE LENGTH (L) (FT)	TRAVEL LANE SHIFT LENGTH (L/2) (FT)	BUFFER ZONE LENGTH (FT)	DEVICE SPACING (FT)	MIN # OF DEVICES*
25-40	110	320	160	305	20	70
45-55	220	660	330	495	40	55
60-65	260	780	390	645	40	65









\* NUMBER OF DEVICES BASED ON 400 FT WORK ZONE.

POSTED SPEED LIMIT (MPH)	SPACING FOR ADVANCE WARNING SIGNS (FT) (A,B,C)
25-40	500 / 500 / 500
45-55	500 / 1000 / 1000
60-65	1000 / 1600 / 2600

**NOTES**

1. MA-R2-10a LOCATED AT C/2.

**LEGEND**

-  WORK ZONE
-  CHANNELIZATION DEVICE
-  FLASHING ARROW BOARD
-  PORTABLE CHANGEABLE MESSAGE SIGN
-  TRUCK MOUNTED ATTENUATOR
-  RADAR SPEED FEEDBACK BOARD
-  POLICE DETAIL OR UNIFORMED FLAGGER
-  TEMPORARY PORTABLE RUMBLE STRIP
-  TYPE III BARRICADE

NOT TO SCALE



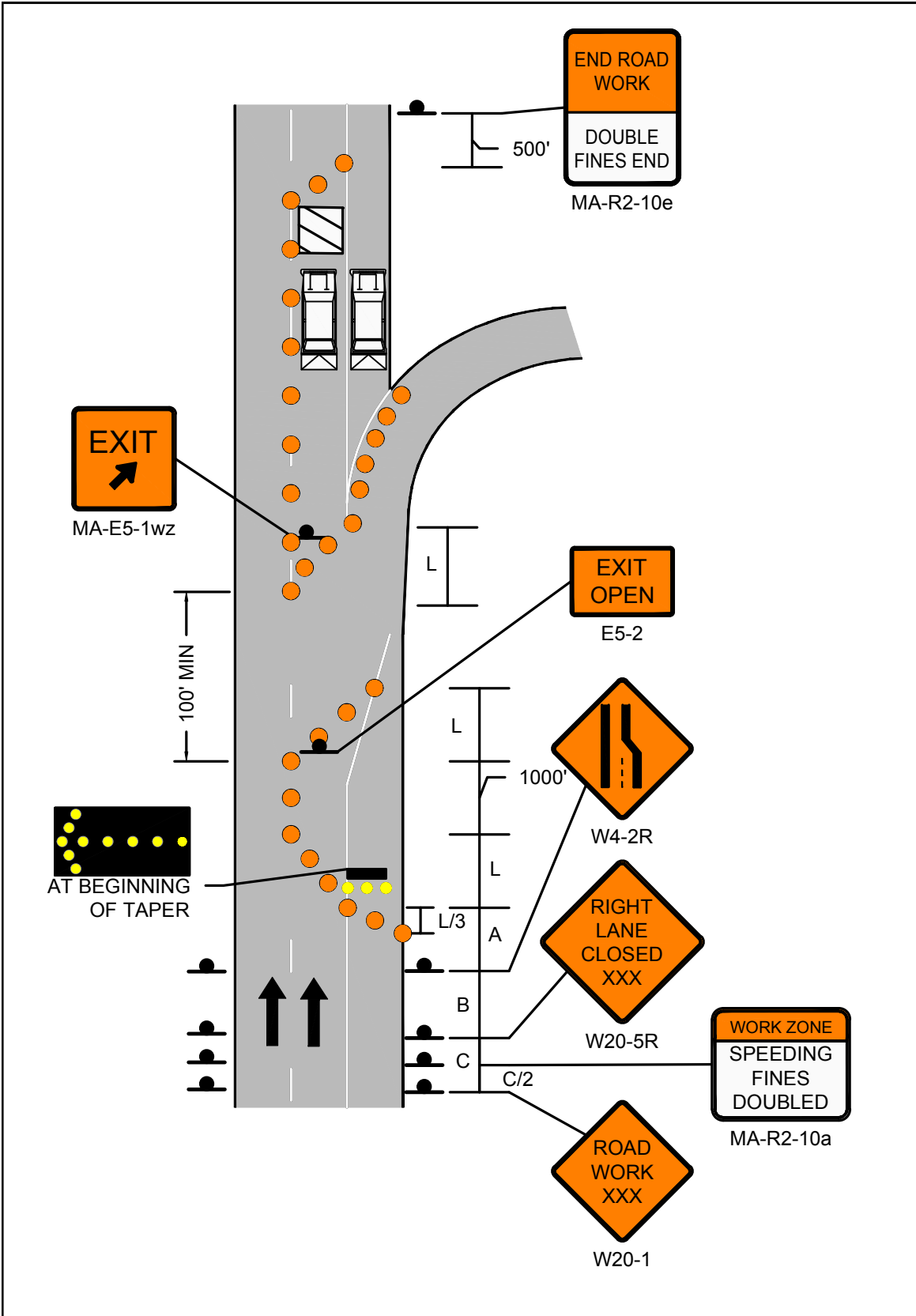

 <p>PAGE 47</p>	<p>Work Zone Safety Standard Details and Drawings</p>	<p>FIGURE 20 STATIONARY OPERATIONS MULTILANE DIVIDED ROADWAY ROADWORK BEYOND OFF RAMP</p>
--	---	---



PAGE 48

Work Zone Safety  
Standard Details  
and Drawings









MULTILANE DIVIDED ROADWAY  
TYPICAL RAMP CLOSURE

POSTED SPEED LIMIT (MPH)	SPACING FOR ADVANCE WARNING SIGNS (FT) (A,B,C)	CHANNELIZATION DEVICES (DRUMS OR CONES)			
		SHOULDER TAPER LENGTH (L/3) (FT)	BUFFER ZONE LENGTH (FT)	DEVICE SPACING (FT)	MIN # OF DEVICES
25-40	500 / 500 / 500	110	305	20	45
45-55	500 / 1000 / 1000	220	495	40	30
60-65	1000 / 1600 / 2600	260	645	40	35

**NOTES**

1. MA-R2-10a LOCATED AT C/2.
2. \* NOT REQUIRED IF RIGHT LANE IS CLOSED IN ADVANCE OF EXIT.
3. \*\* OPTIONAL AT ENGINEER'S DISCRETION.

**LEGEND**

-  WORK ZONE
-  CHANNELIZATION DEVICE
-  FLASHING ARROW BOARD
-  PORTABLE CHANGEABLE MESSAGE SIGN
-  TRUCK MOUNTED ATTENUATOR
-  RADAR SPEED FEEDBACK BOARD
-  POLICE DETAIL OR UNIFORMED FLAGGER
-  TEMPORARY PORTABLE RUMBLE STRIP
-  TYPE III BARRICADE

NOT TO SCALE

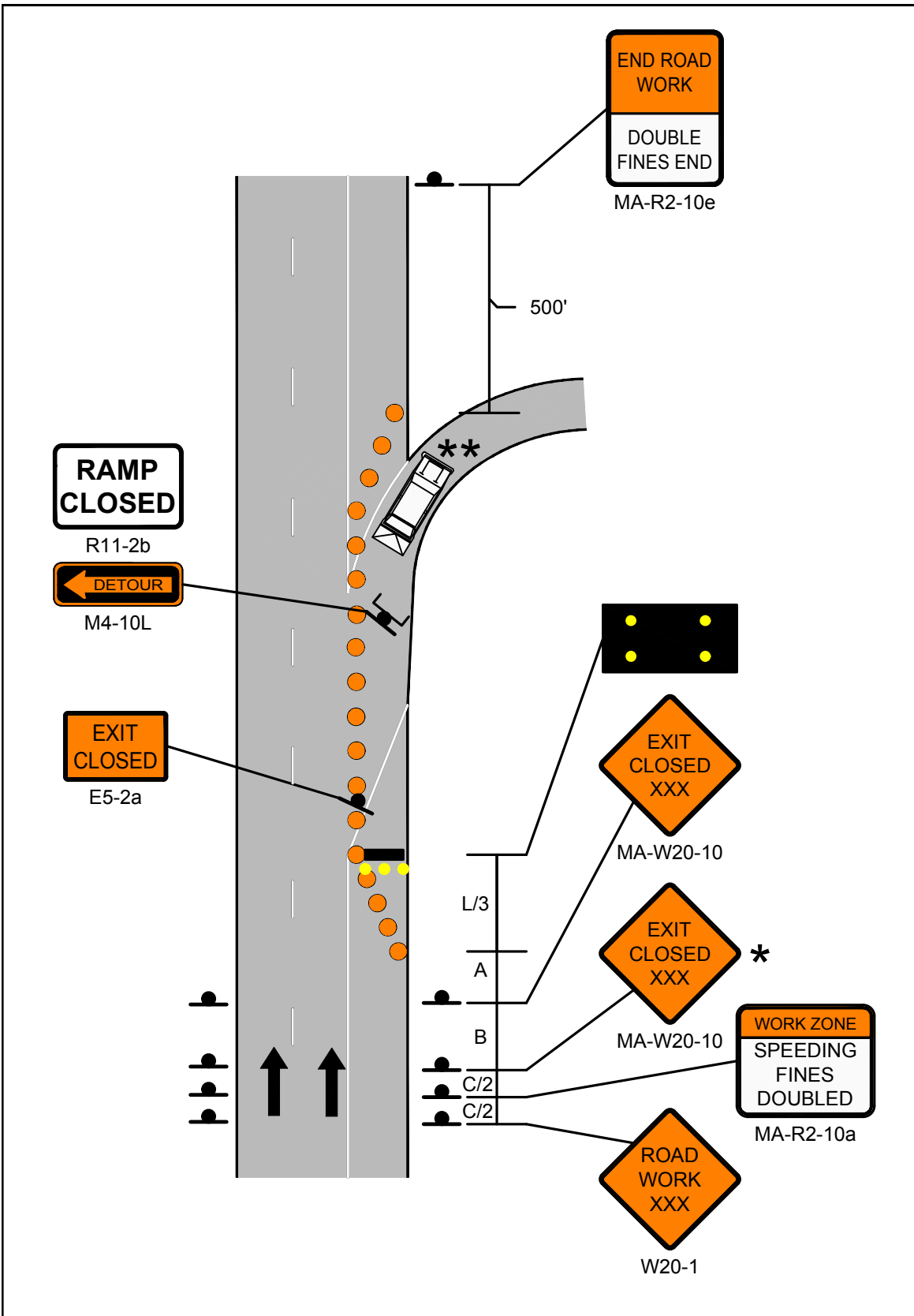



PAGE 50

Work Zone Safety  
Standard Details  
and Drawings









MULTILANE DIVIDED ROADWAY  
TYPICAL CLOVERLEAF RAMP CLOSURE

POSTED SPEED LIMIT (MPH)	SPACING FOR ADVANCE WARNING SIGNS (FT) (A,B,C)	CHANNELIZATION DEVICES (DRUMS OR CONES)			
		SHOULDER TAPER LENGTH (L/3) (FT)	BUFFER ZONE LENGTH (FT)	DEVICE SPACING (FT)	MIN # OF DEVICES
25-40	500 / 500 / 500	110	305	20	45
45-55	500 / 1000 / 1000	220	495	40	30
60-65	1000 / 1600 / 2600	260	645	40	35

NOTES

1. MA-R2-10a LOCATED AT C/2.
2. \* NOT REQUIRED IF RIGHT LANE IS CLOSED IN ADVANCE OF EXIT.
3. \*\* OPTIONAL AT ENGINEER'S DISCRETION.

LEGEND

-  WORK ZONE
-  CHANNELIZATION DEVICE
-  FLASHING ARROW BOARD
-  PORTABLE CHANGEABLE MESSAGE SIGN
-  TRUCK MOUNTED ATTENUATOR
-  RADAR SPEED FEEDBACK BOARD
-  POLICE DETAIL OR UNIFORMED FLAGGER
-  TEMPORARY PORTABLE RUMBLE STRIP
-  TYPE III BARRICADE

NOT TO SCALE

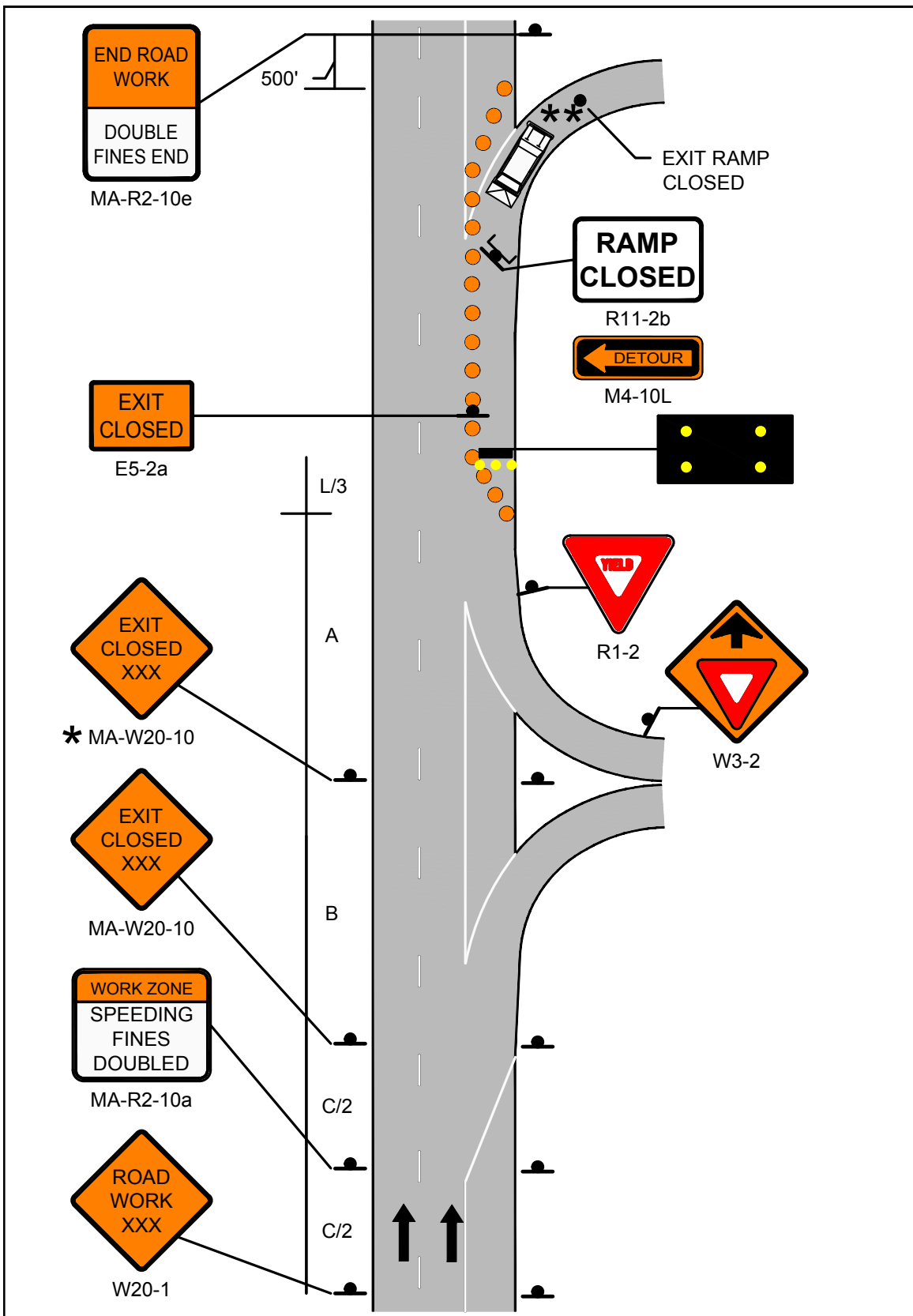

 <p>Massachusetts Department of Transportation Highway Division</p> <p>PAGE 51</p>	<p>Work Zone Safety Standard Details and Drawings</p>	<p>FIGURE 22 MULTILANE DIVIDED ROADWAY TYPICAL CLOVERLEAF RAMP CLOSURE</p>
---	---	--



PAGE 52









Work Zone Safety  
Standard Details  
and Drawings

MULTILANE DIVIDED ROADWAY  
TYPICAL RAMP CLOSURE  
ADVANCE SIGNING

NOTES

1. IF THE CLOSED RAMP IS LOCATED DOWNSTREAM FROM THE PROPOSED DETOUR ROUTE/RAMP, A PCMS SHALL BE POSITIONED AT A SUFFICIENT DISTANCE IN ADVANCE OF THE DETOUR ROUTE/RAMP AND SHOULD STATE WHICH RAMP IS CLOSED AND WHICH SHALL BE USED FOR THE DETOUR.
2. IF THE CLOSED RAMP IS LOCATED UPSTREAM FROM THE PROPOSED DETOUR ROUTE/RAMP, A PCMS SHALL BE POSITIONED PRIOR TO THE CLOSED RAMP AND SHOULD STATE WHICH RAMP IS CLOSED AND WHICH SHALL BE USED FOR THE DETOUR.
3. A SUFFICIENT NUMBER OF DETOUR SIGNS (M4-9 SERIES) SHOULD BE DEPLOYED TO PROPERLY DIRECT DETOURED TRAFFIC. SIGN SPACING SHALL BE AT THE DIRECTION OF THE ENGINEER.

LEGEND

-  WORK ZONE
-  CHANNELIZATION DEVICE
-  FLASHING ARROW BOARD
-  PORTABLE CHANGEABLE MESSAGE SIGN
-  TRUCK MOUNTED ATTENUATOR
-  RADAR SPEED FEEDBACK BOARD
-  POLICE DETAIL OR UNIFORMED FLAGGER
-  TEMPORARY PORTABLE RUMBLE STRIP
-  TYPE III BARRICADE

NOT TO SCALE

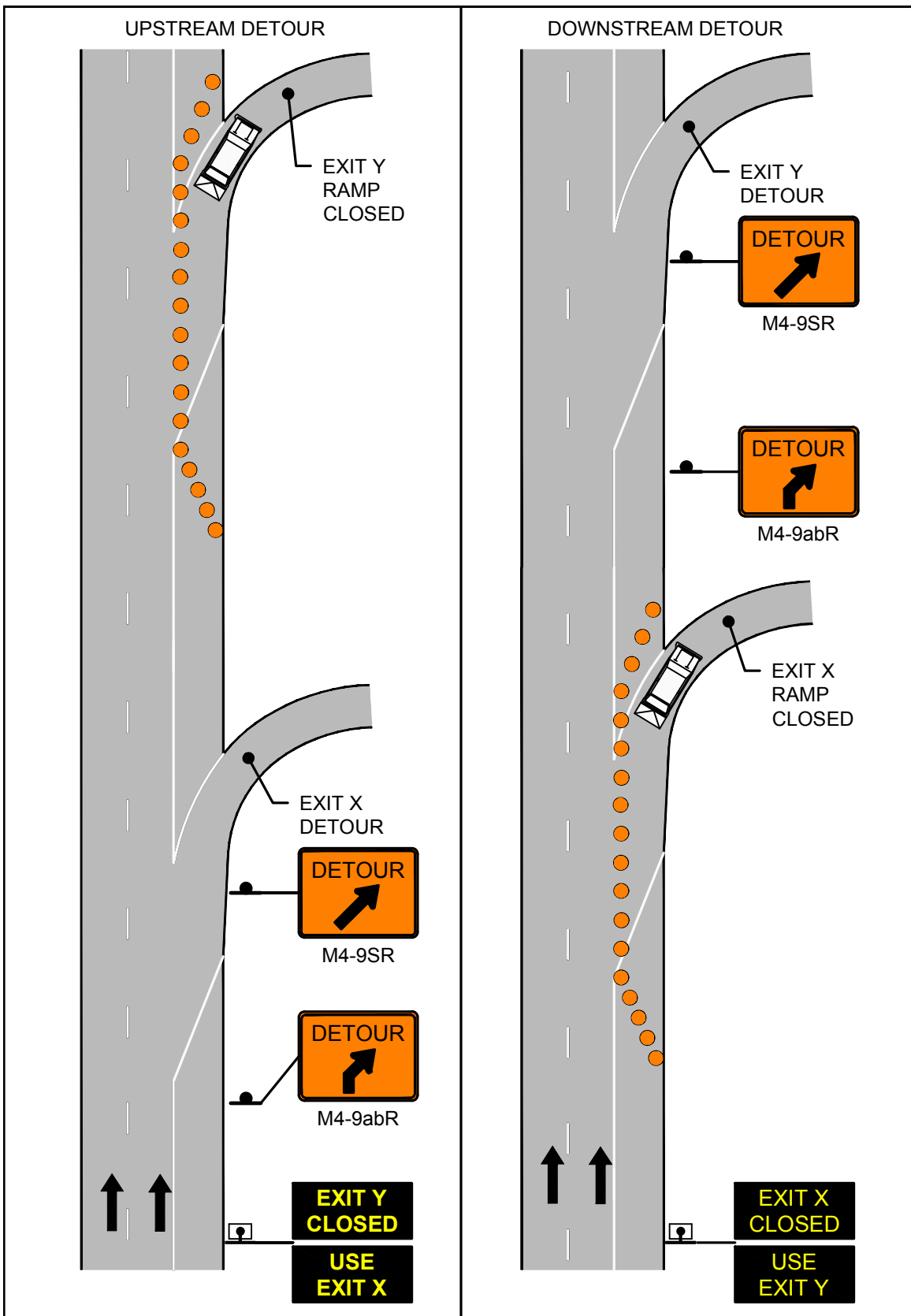

FIGURE 23  
MULTILANE DIVIDED ROADWAY  
TYPICAL RAMP CLOSURE  
ADVANCE SIGNING



FIGURE 24-1  
MULTILANE DIVIDED ROADWAY  
PLACEMENT OF TEMPORARY  
PORTABLE RUMBLE STRIPS  
SHEET 1 OF 2



POSTED REGULATORY OR WORK ZONE SPEED	SEPARATION BETWEEN RUMBLE STRIPS
Above 55-mph	20-feet
36-mph to 55-mph	15-feet
35-mph and under	10-feet

POSTED SPEED LIMIT (MPH)	SPACING FOR ADVANCE WARNING SIGNS (FT) (A,B,C)	TANGENT LENGTH BETWEEN TAPERS (T) (FT)
25-40	500 / 500 / 500	640
45-55	500 / 1000 / 1000	1320
60-65	1000 / 1600 / 2600	1560

**NOTES**

1. THE INTENTION OF THESE DETAILS IS ONLY TO DEPICT THE PLACEMENT OF TEMPORARY PORTABLE RUMBLE STRIPS (TPRS) IN RELATIONSHIP TO THE TAPER AND THE BUFFER OF A SINGLE- OR MULTI-LANE CLOSURE. THE DEPICTION OF THE NUMBER AND SPACING OF ALL OTHER TRAFFIC CONTROL DEVICES IS NOT TO SCALE. REFER TO OTHER DETAILS FOR LANE CLOSURES FOR THE PLACEMENT AND NUMBER OF ALL OTHER TRAFFIC CONTROL DEVICES.
2. THESE DETAILS ONLY DEPICT RIGHT LANE CLOSURES. LEFT LANE CLOSURES SHOULD UTILIZE A MIRROR IMAGE OF THESE SETUPS, STARTING WITH CLOSURE OF THE LEFTMOST LANE.
3. ★ THIS TPRS ARRAY IS OPTIONAL AT THE ENGINEER'S DISCRETION. IF USED, IT SHOULD BE PLACED ADJACENT TO THE BUFFER.
4. DETAILS SHOW THE MINIMUM NUMBER OF TPRS REQUIRED. ADDITIONAL MAY BE USED IF CONDITIONS WARRANT.

**LEGEND**

-  CHANNELIZATION DEVICE
-  TRUCK MOUNTED ATTENUATOR
-  TEMPORARY PORTABLE RUMBLE STRIP

NOT TO SCALE

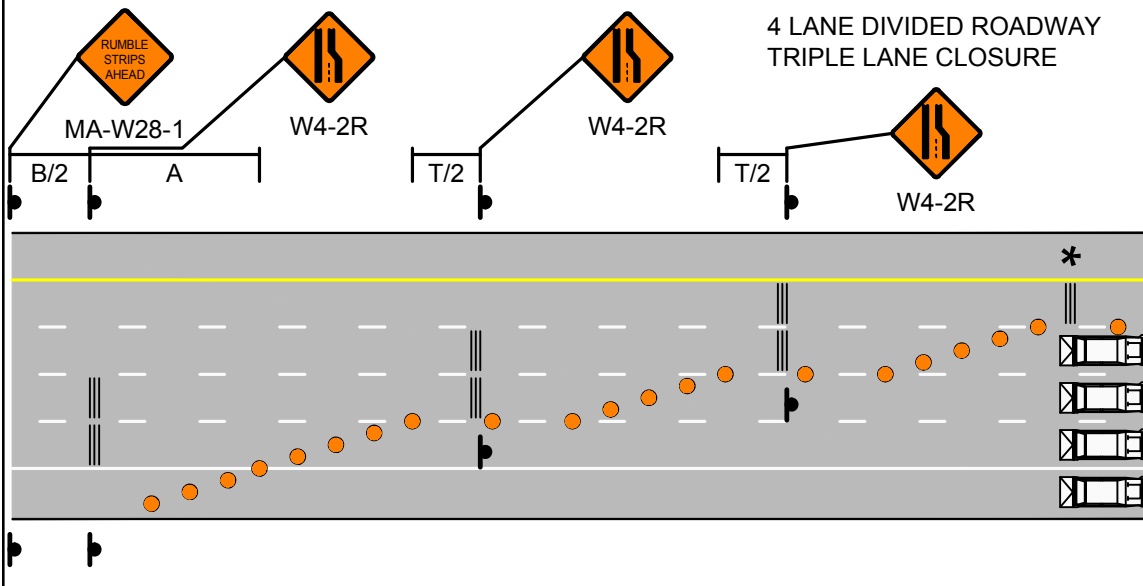



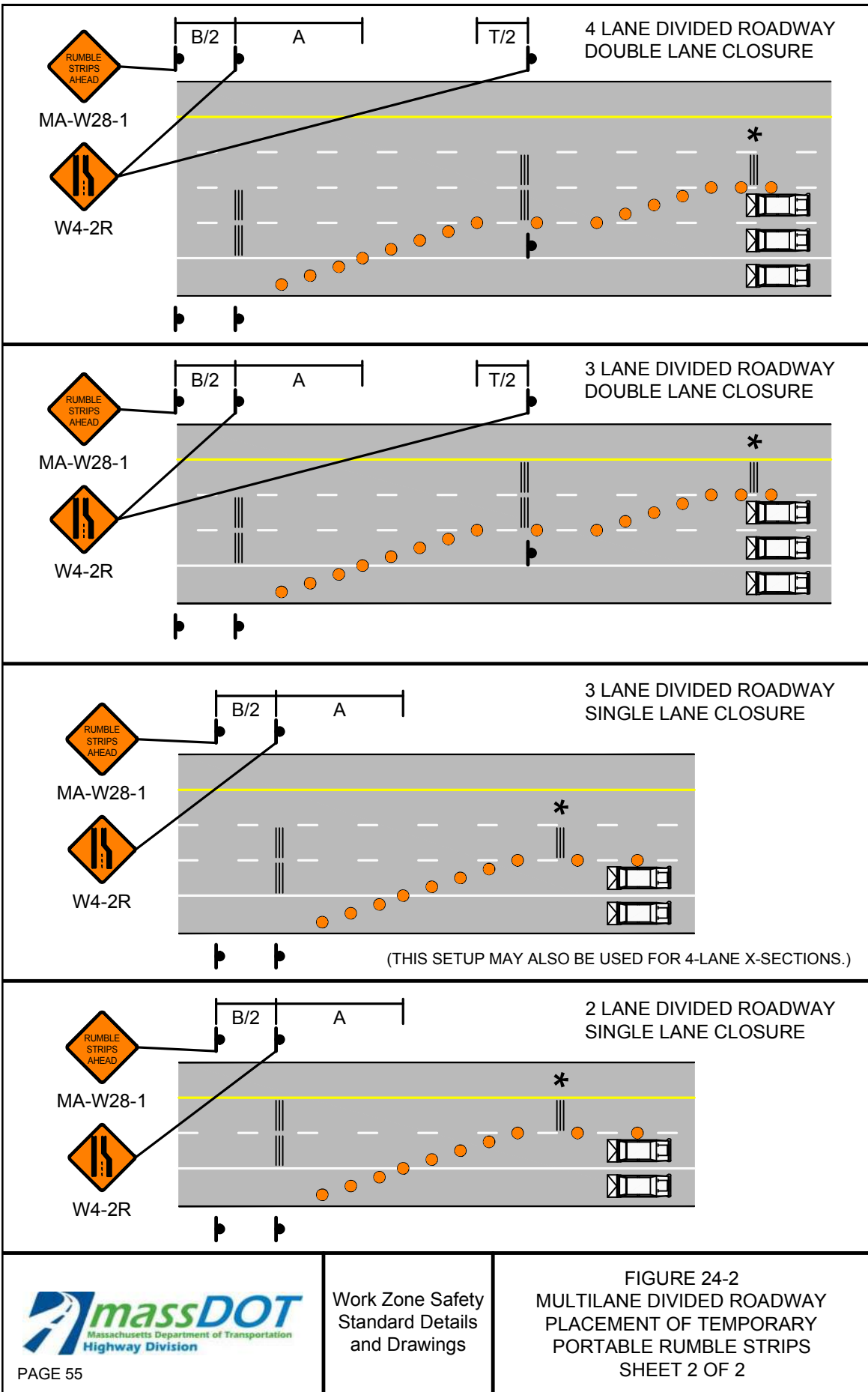



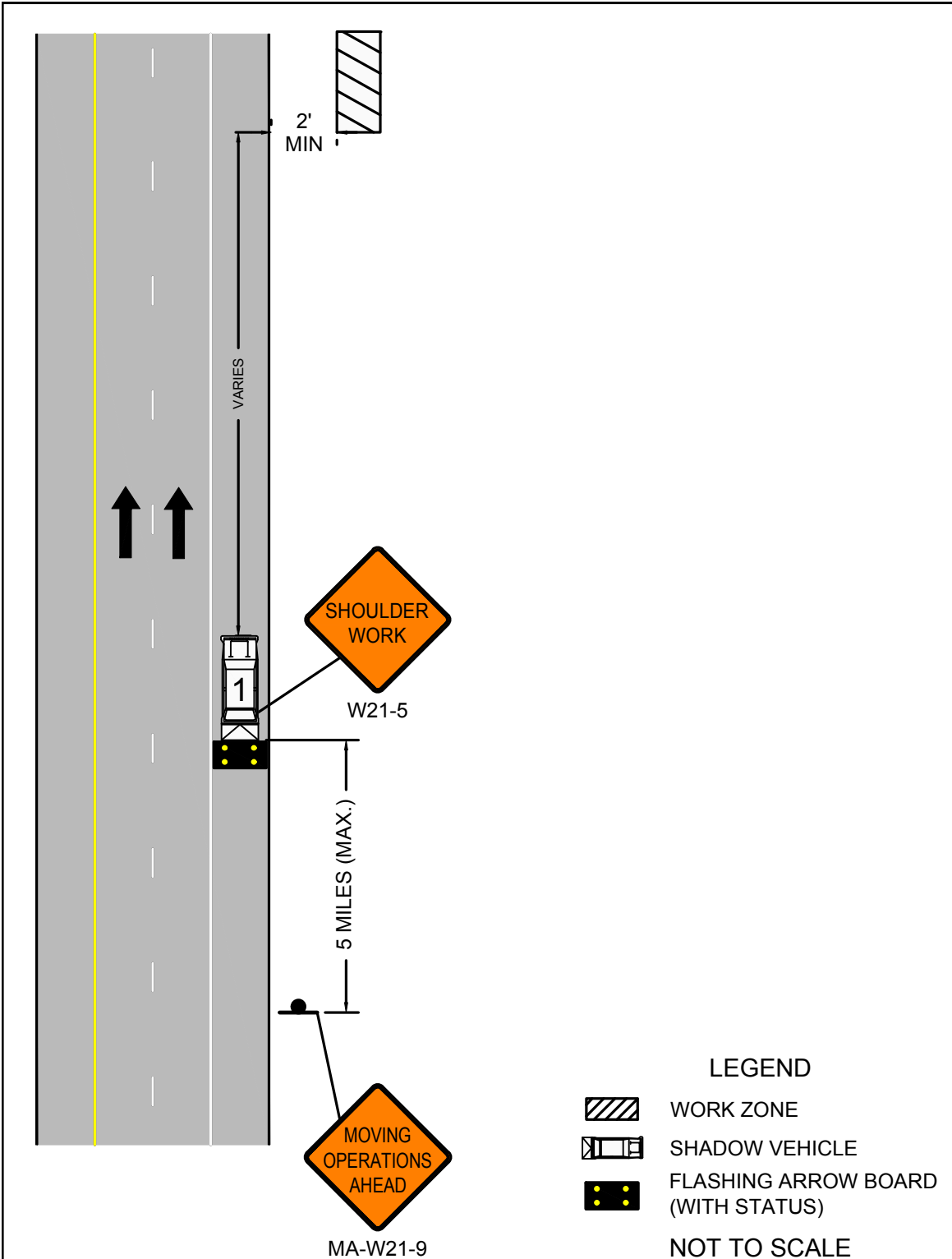

 <p>PAGE 56</p>	<p>Work Zone Safety Standard Details and Drawings</p>	<p>NOTES FOR MOBILE OPERATIONS</p>
--	---	------------------------------------

**Notes for Mobile Operations**

- Unless otherwise stated, these notes shall apply to all Mobile Operation setups.
  - Additional, setup-specific notes may be found on individual sheets.
1. The Supervisor shall travel the designated roadway prior to scheduling the work to ensure that sufficient and appropriate traffic control devices will be available. Special consideration shall be exercised to ensure that appropriate traffic controls be placed in areas that will have limited visibility of the work areas or any associated traffic queues.
  2. Vehicles used for these operations shall be made highly visible with appropriate equipment such as flashing lights, rotating beacons, flags, signs, flashing arrow boards, and/or portable changeable message signs. Any signs mounted to these vehicles shall not obscure the visibility of other devices.
  3. All vehicles shown may not be required based upon roadway conditions. However, when needed and practical, additional shadow vehicles and equipment to warn and protect motorists and workers should be used. Based upon roadway conditions, the addition of a police detail with cruiser may be used for additional protection or warning for the traveling public.
  4. The distance between the work and shadow vehicle(s) may vary according to the terrain and other factors. Shadow vehicles are used to warn traffic of the operations ahead. Whenever adequate sight distance exists, the shadow vehicle(s) should maintain the minimum appropriate distance and maintain the same speed to prevent non-work related vehicles from entering the work convoy. If this formation cannot be maintained then additional traffic control devices should be deployed in advance of any vertical or horizontal curves that may restrict the sight distance of an oncoming vehicle to either the work vehicle or associated traffic queue.
  5. All shadow vehicles shall be equipped with a truck or trailer mounted attenuator (TMA) and a flashing arrow board.
  6. Signs should be covered or turned from view when work is not in progress.
  7. Portable changeable message signs may be used in lieu of MA-W21-9 signs and any signs mounted directly to a shadow vehicle.



LEGEND

-  WORK ZONE
-  SHADOW VEHICLE
-  FLASHING ARROW BOARD (WITH STATUS)

NOT TO SCALE

NOTES

1. IF THE WORK AREA IS SUFFICIENTLY AWAY FROM THE EDGE OF ROADWAY (20' MINIMUM) THEN SIGNS AND VEHICLES MAY NOT BE REQUIRED.



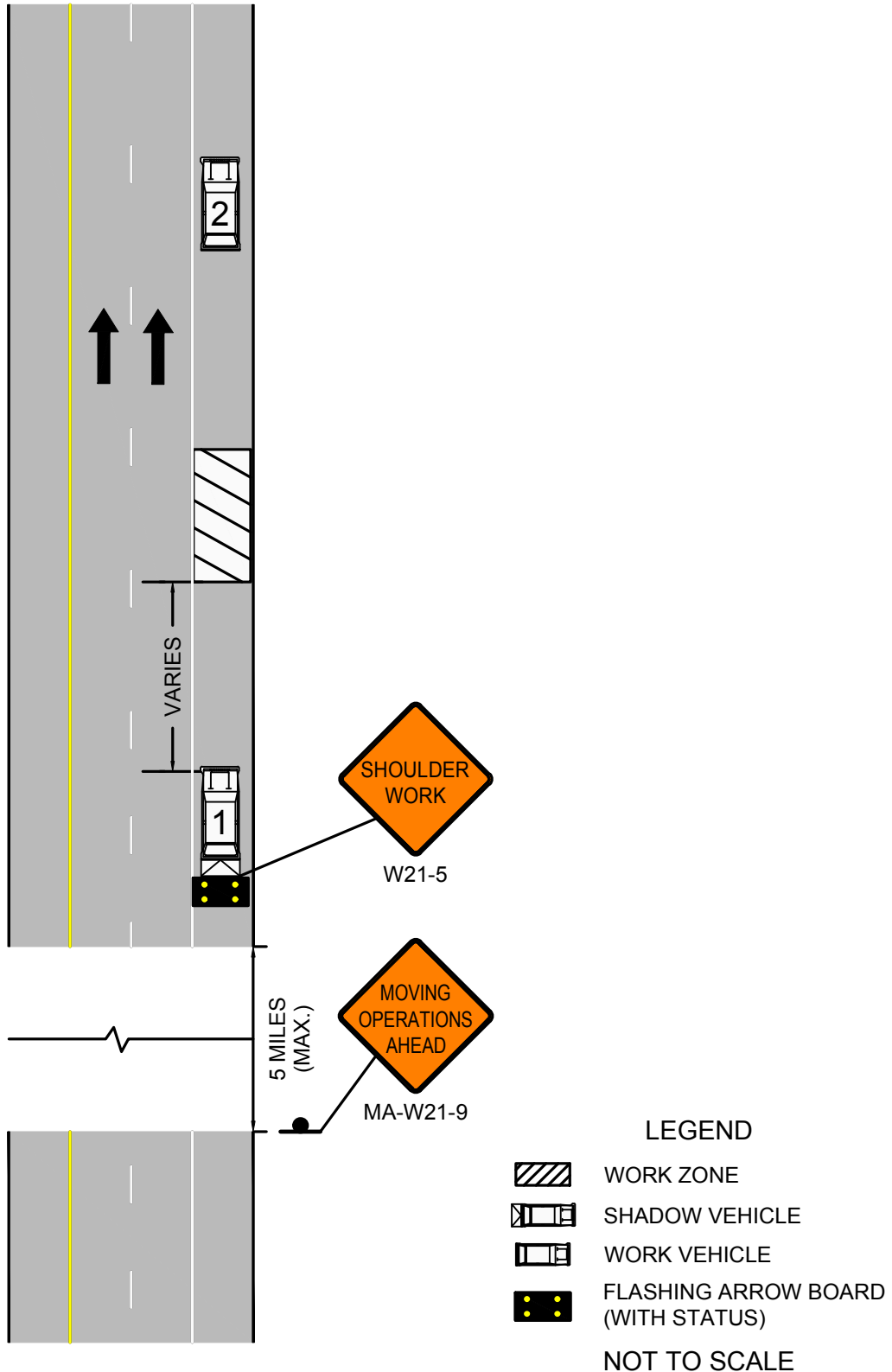

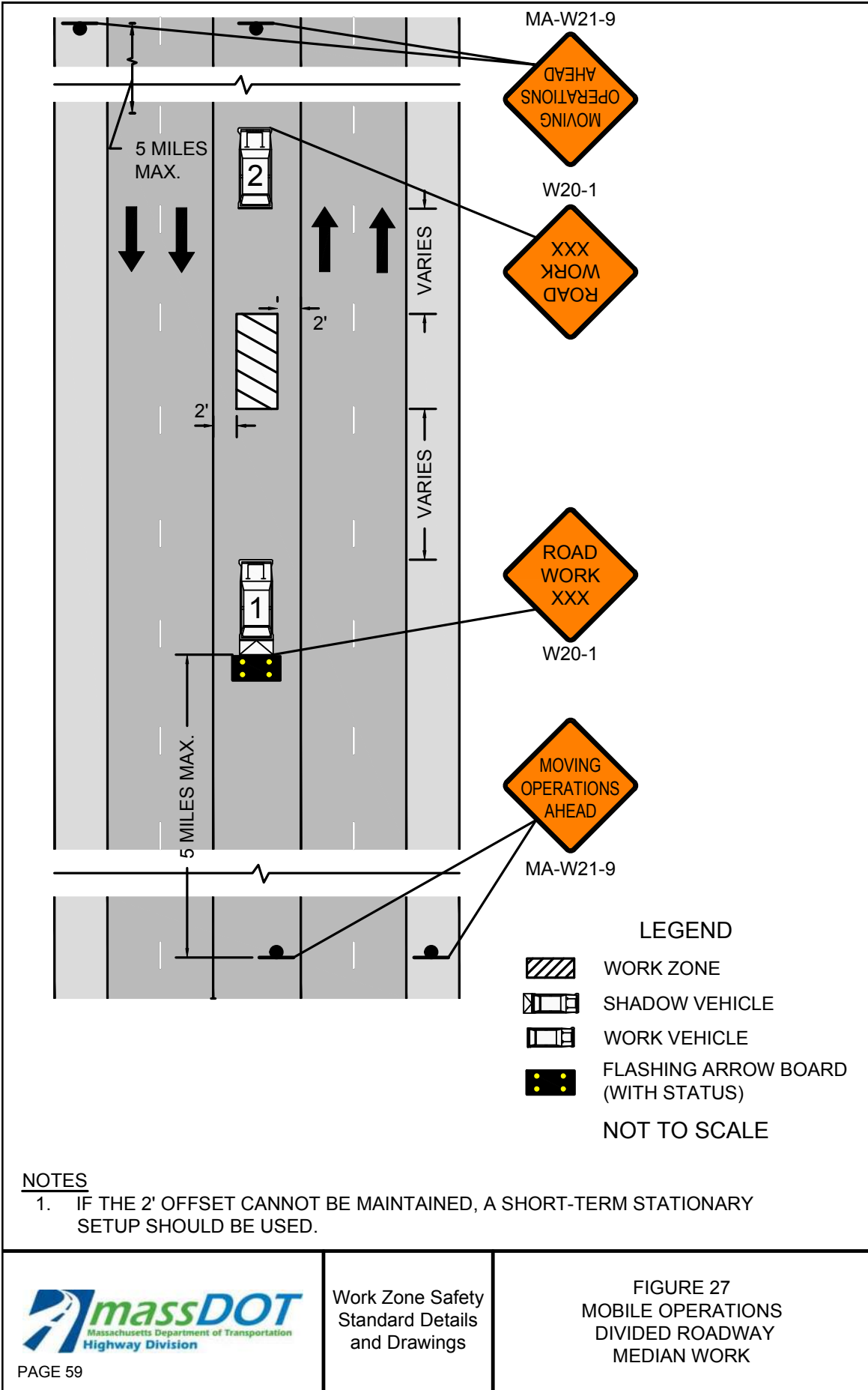
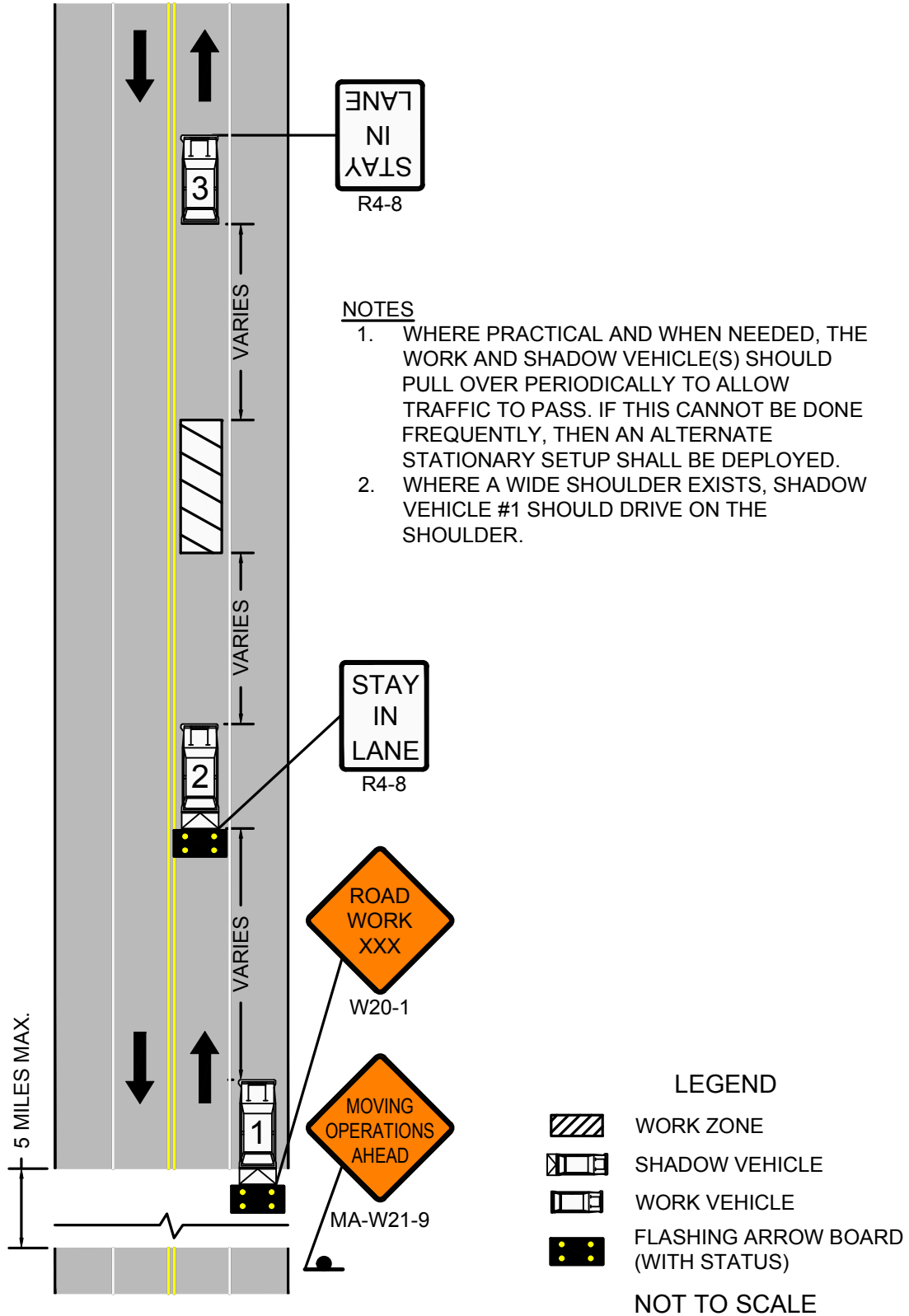



FIGURE 28  
MOBILE OPERATIONS  
UNDIVIDED TWO LANE ROADWAY  
HALF OF ROADWAY CLOSED



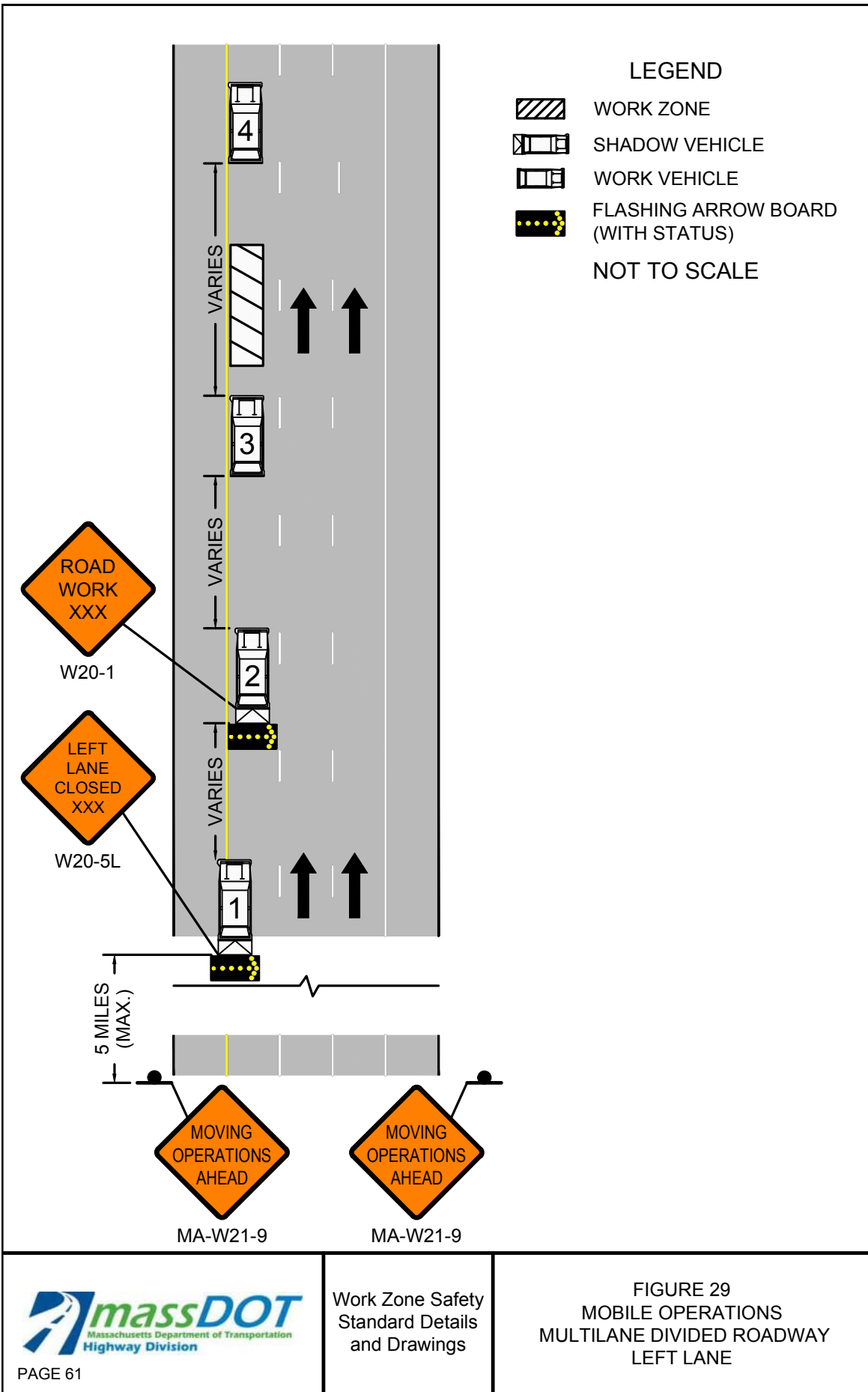
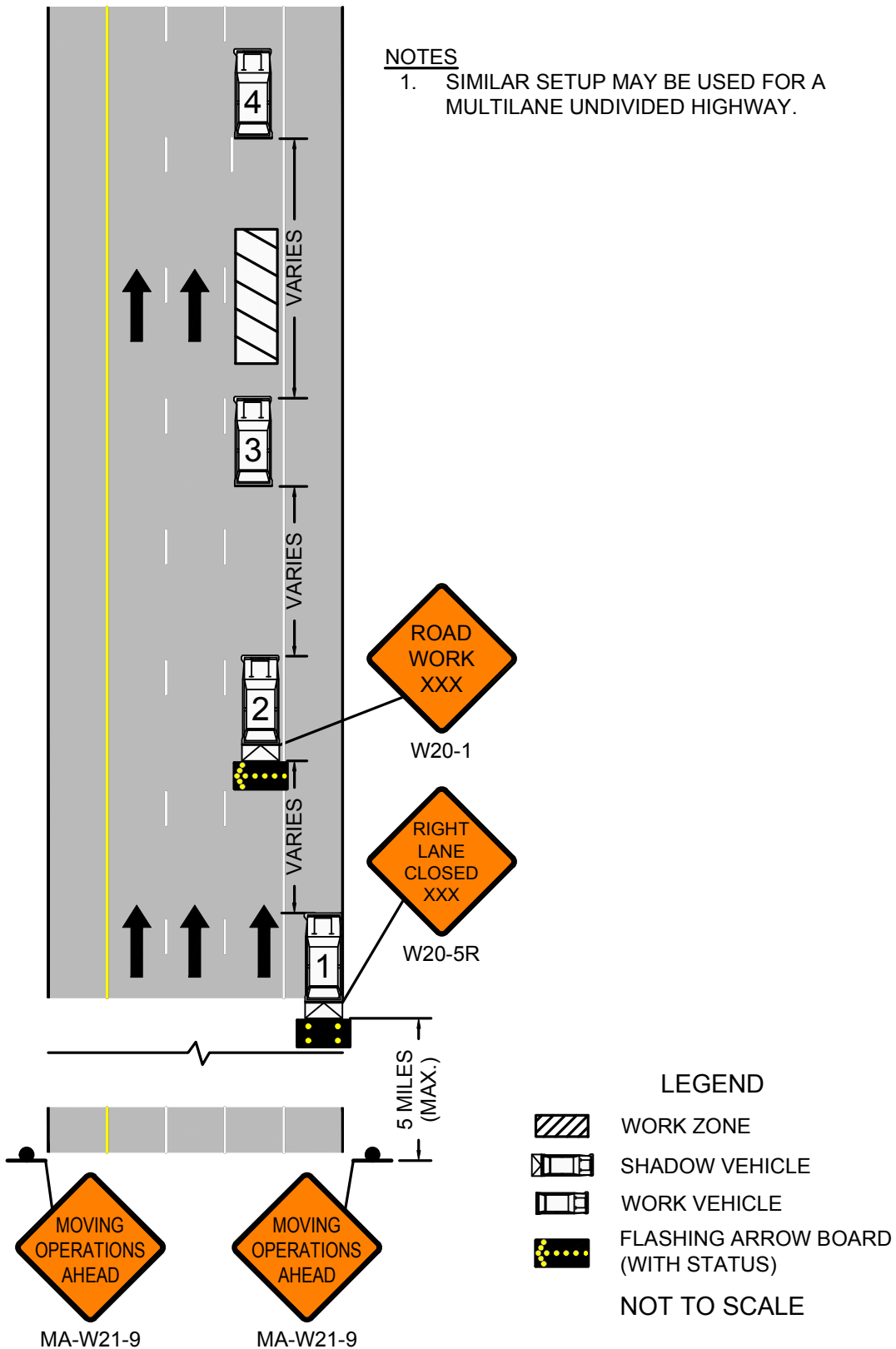
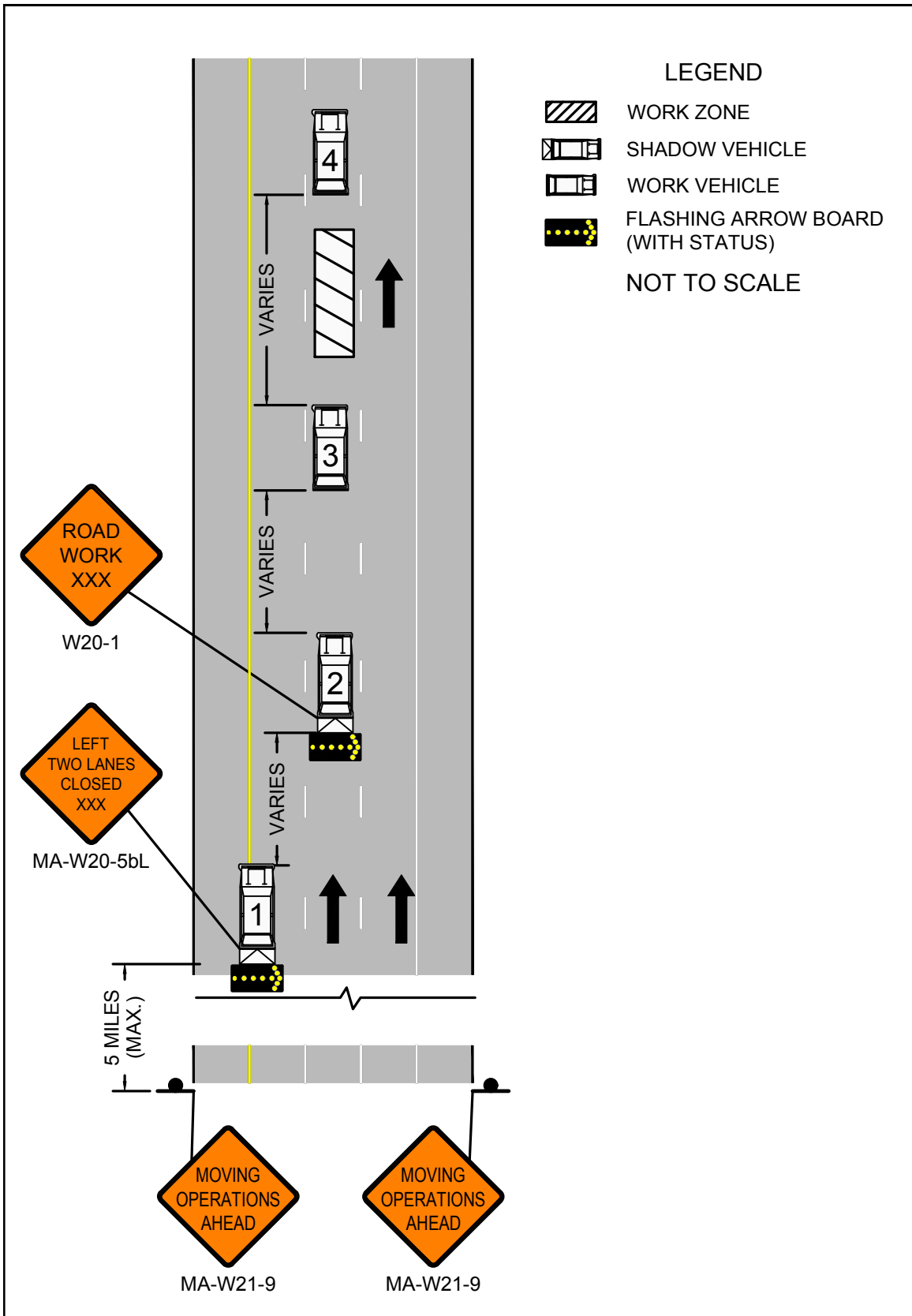

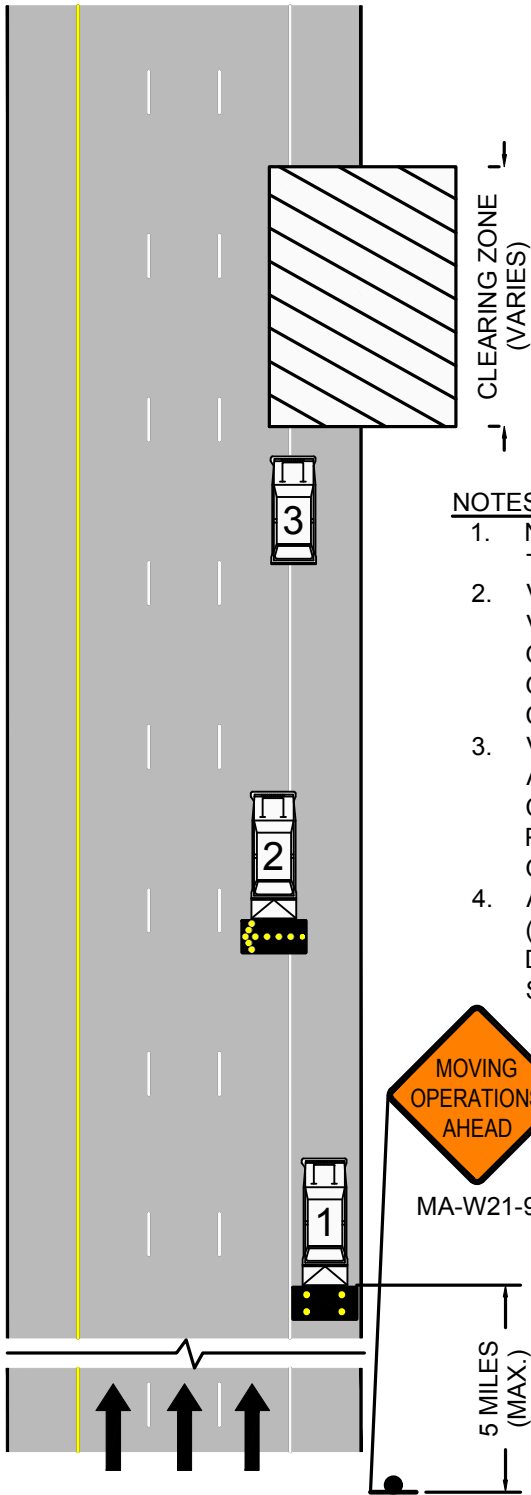

FIGURE 30  
MOBILE OPERATIONS  
MULTILANE DIVIDED ROADWAY  
RIGHT LANE









**NOTES**

1. NO OTHER NOTES ARE APPLICABLE TO THIS DETAIL.
2. VEHICLE #3 IS A SNOW/DEBRIS REMOVAL VEHICLE AND SHALL ALWAYS BE AWARE OF THE SURROUNDINGS. MORE THAN ONE VEHICLE MAY BE USED IN THE CLEARING ZONE.
3. VEHICLE #1 SHOULD BE EQUIPPED WITH A PCMS, A TMA, AND STAY IN VISUAL CONTACT WITH VEHICLE #3 WHILE PROVIDING AMPLE WARNING TO ONCOMING TRAFFIC.
4. A POLICE DETAIL WITH BLUE LIGHTS (OPTIONAL) SHALL REMAIN DOWNSTREAM OF VEHICLE #1 IN THE SHOULDER.

**LEGEND**

- WORK ZONE
- SHADOW VEHICLE
- WORK VEHICLE
- FLASHING ARROW BOARD (WITH STATUS)

NOT TO SCALE

**Notes for Traffic Emergency or Incident Operations**

- The goal is to increase awareness of during traffic emergencies or incidents.
- These signs are to be used to differentiate from the traditional construction work zone and an emergency or incident.
- Upon arrival MassDOT First Responders shall assess the magnitude of the scene to determine if the incident is likely to last an hour or more in duration which would trigger the requirement to use these signs.
- Place the “Emergency Ahead” sign on the same side of the road as the incident, if possible, for up to an hour. Emergency response signs should be put up for all incidents and emergencies as soon as possible.
- Place the emergency sign 500 to 1000 feet before the first channelization devices.
- As an incident evolves this sign would be used as a secondary sign with all other emergency controls put in place.
- Only use “MERGE” signs where applicable (Not on 2 lane roads).
- Use MERGE signs on Multi-lane Roads to move traffic away from the incident and keep them in a safe lane.
- Place the MERGE sign about 500 feet before the closure.
- If additional signs are available, they should be placed accordingly as a sign informing people coming in the other direction or on the opposite side of the roadway.
- Use 12 emergency cones spaced 40 to 80 feet apart to form a taper and protect the scene.
- Sequential flashing lights/flares may be used in lieu of or to supplement cones.
- During a major incident that will last for a long duration, the EMERGENCY AHEAD sign should be moved back before an intersecting road or ramp to alert travelers and give them an option of using an alternate route. (Be sure all other devices are in place before moving this sign).

**Standard Emergency Signs (36"x36" or 48"x48")**



MA-W20-9

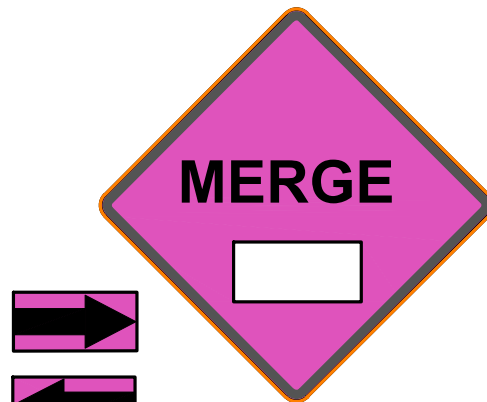



MA-W4-2aR/L



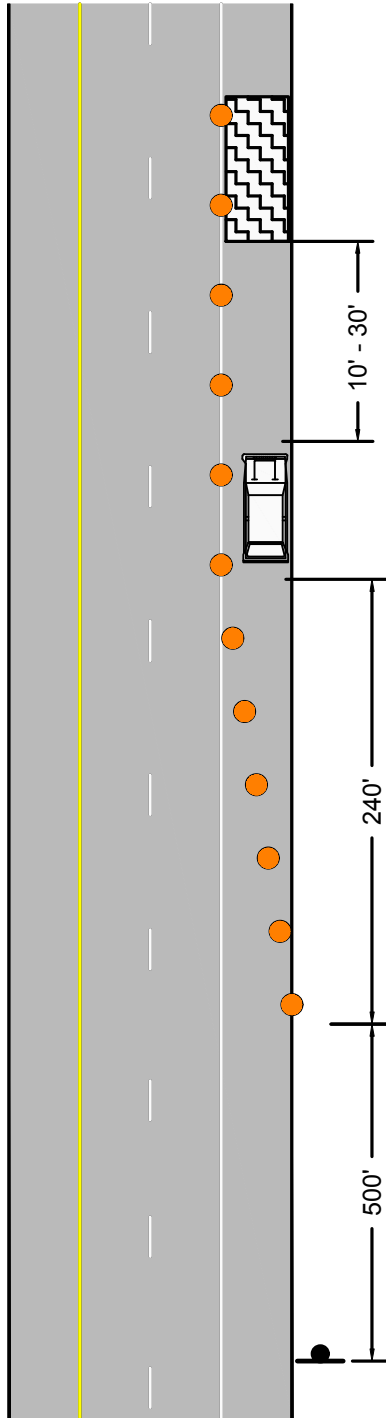

FIGURE 33  
EMERGENCY RESPONSE  
ANY ROADWAY  
SHOULDER ENCROACHMENT

LEGEND

-  EMERGENCY AREA
-  CHANNELIZATION DEVICE
-  EMERGENCY RESPONSE VEHICLE

NOT TO SCALE



ORDER OF RESPONSE ACTIVITIES

1. ACTIVATE HAZARD WARNING LIGHTS AND FLASHERS. PULL VEHICLE OVER TO THE RIGHT EDGE OF TRAVEL LANE BEFORE STOPPING.
2. IF EMERGENCY INVOLVES AN INJURY, SKIP TO STEP 4 THEN RETURN TO STEP 3.
3. ERECT SIGNS AND PLACE TRAFFIC CONES. USE 40' SPACING BETWEEN CONES.
4. TEND TO EMERGENCY/INCIDENT.

NOTES

1. ON HILLY TERRAIN, SHARP CURVES, IN HEAVY TRAFFIC, OR WITH HIGH SPEEDS, CONE SPACING MAY BE DOUBLED TO 80'.
2. REQUEST ADDITIONAL ASSISTANCE AND/OR TRAFFIC CONTROL DEVICES, IF NEEDED.



MA-W20-9

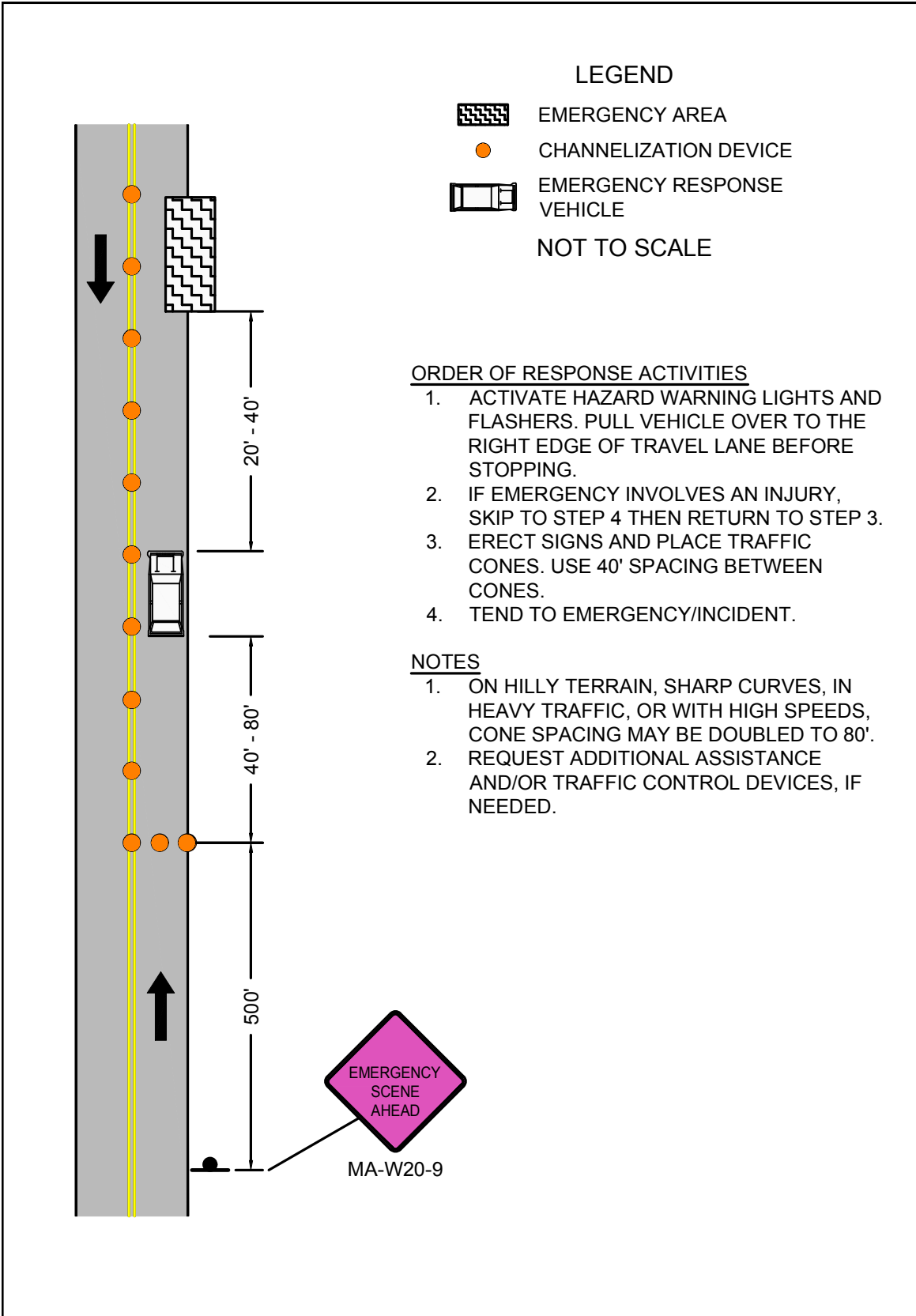





 <p>Massachusetts Department of Transportation Highway Division</p>	<p>Work Zone Safety Standard Details and Drawings</p>	<p><b>FIGURE 34</b> EMERGENCY RESPONSE TWO LANE ROADWAY NO SHOULDER TRAVEL LANE ENCROACHMENT</p>
--	---	--

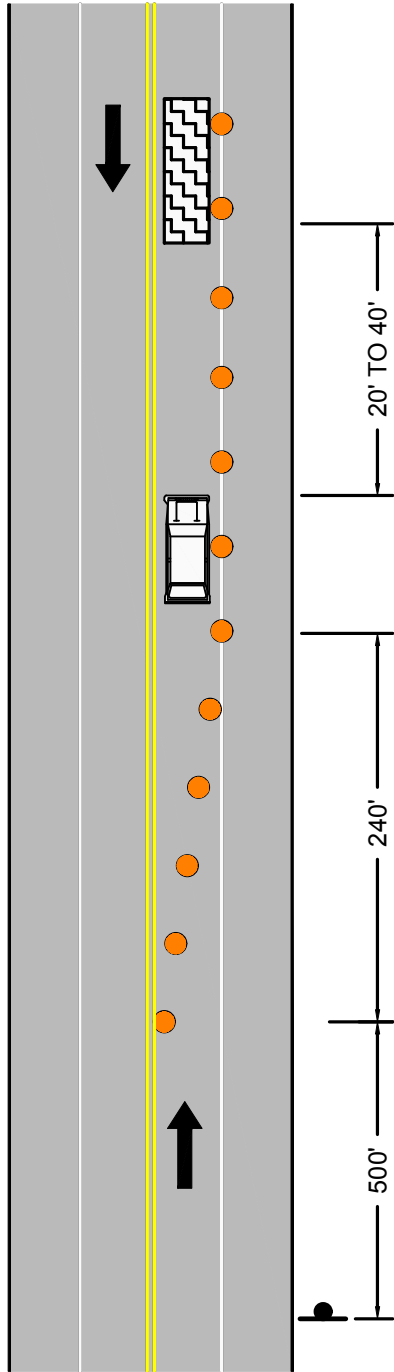

FIGURE 35  
EMERGENCY RESPONSE  
TWO LANE ROADWAY  
TRAVERSABLE SHOULDER  
SINGLE LANE ENCROACHMENT

LEGEND

-  EMERGENCY AREA
-  CHANNELIZATION DEVICE
-  EMERGENCY RESPONSE VEHICLE

NOT TO SCALE



ORDER OF RESPONSE ACTIVITIES

1. ACTIVATE HAZARD WARNING LIGHTS AND FLASHERS. PULL VEHICLE OVER TO THE LEFT EDGE OF TRAVEL LANE BEFORE STOPPING.
2. IF EMERGENCY INVOLVES AN INJURY, SKIP TO STEP 4 THEN RETURN TO STEP 3.
3. ERECT SIGNS AND PLACE TRAFFIC CONES. USE 40' SPACING BETWEEN CONES.
4. TEND TO EMERGENCY/INCIDENT.

NOTES

1. ON HILLY TERRAIN, SHARP CURVES, IN HEAVY TRAFFIC, OR WITH HIGH SPEEDS, CONE SPACING MAY BE DOUBLED TO 80'.
2. REQUEST ADDITIONAL ASSISTANCE AND/OR TRAFFIC CONTROL DEVICES, IF NEEDED.



MA-W20-9

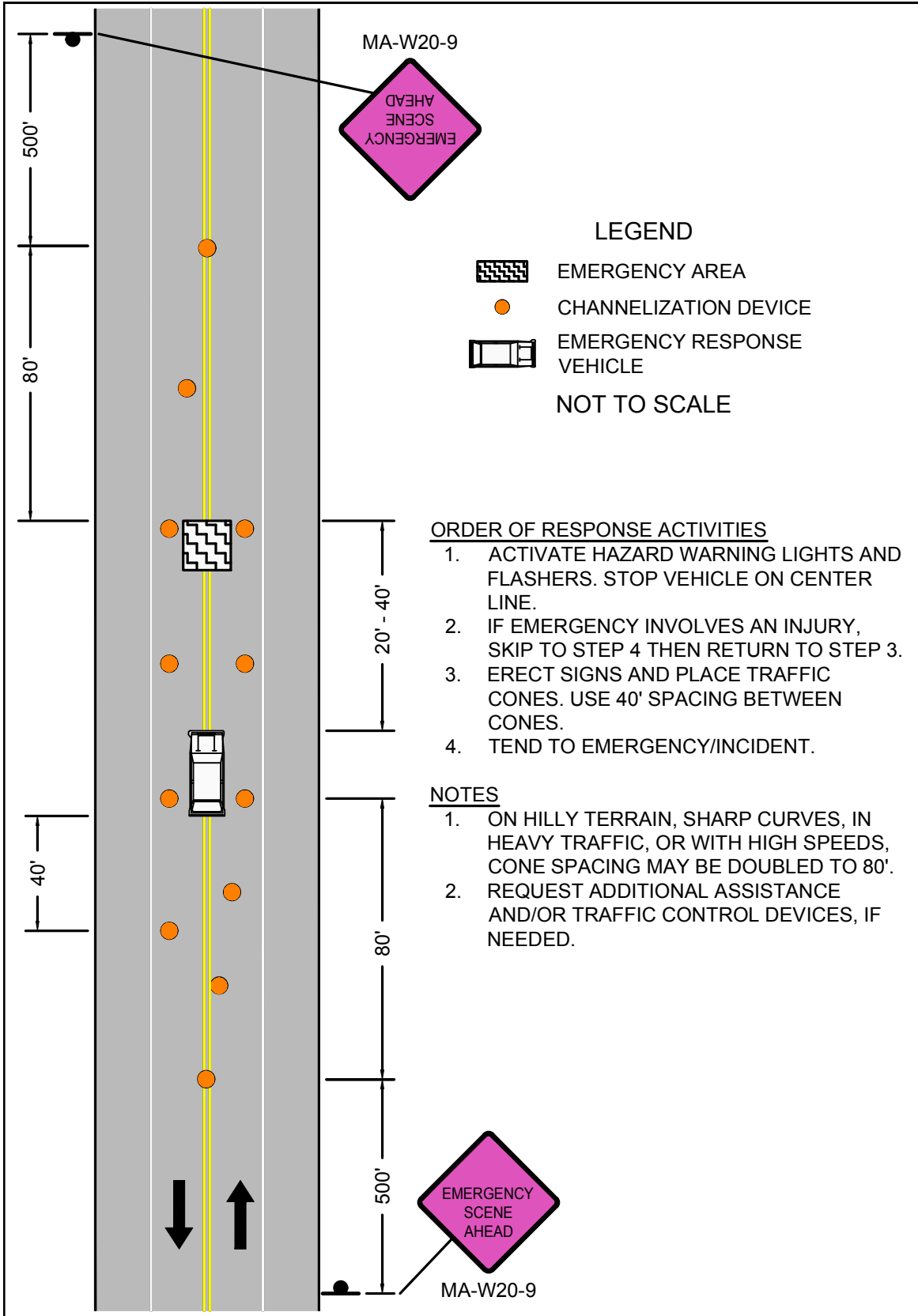





 <p>Massachusetts Department of Transportation Highway Division</p> <p>PAGE 69</p>	<p>Work Zone Safety Standard Details and Drawings</p>	<p>FIGURE 36 EMERGENCY RESPONSE TWO LANE ROADWAY TRAVERSABLE SHOULDER CENTER OF ROADWAY</p>
---	---	---



FIGURE 37  
EMERGENCY RESPONSE  
MULTILANE DIVIDED ROADWAY  
RIGHT LANE

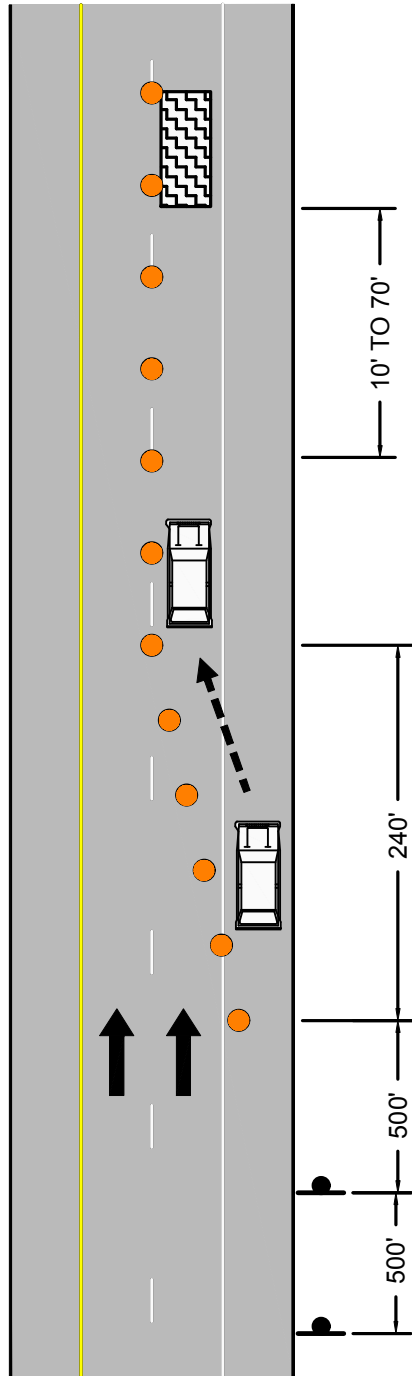

LEGEND

-  EMERGENCY AREA
-  CHANNELIZATION DEVICE
-  EMERGENCY RESPONSE VEHICLE
-  RESPONSE VEHICLE MOVEMENT

NOT TO SCALE

ORDER OF RESPONSE ACTIVITIES

1. ACTIVATE HAZARD WARNING LIGHTS AND FLASHERS. STOP VEHICLE IN BREAKDOWN LANE.
2. IF EMERGENCY INVOLVES AN INJURY, SKIP TO STEP 6 THEN RETURN TO STEP 3.
3. ERECT SIGNS AND PLACE TRAFFIC CONES. USE 40' SPACING BETWEEN CONES.
4. MOVE RESPONSE VEHICLE BEHIND EMERGENCY.
5. PLACE ADDITIONAL CONES.
6. TEND TO EMERGENCY.

NOTES

1. ON HILLY TERRAIN, SHARP CURVES, IN HEAVY TRAFFIC, OR WITH HIGH SPEEDS, CONE SPACING MAY BE DOUBLED TO 80'.
2. REQUEST ADDITIONAL ASSISTANCE AND/OR TRAFFIC CONTROL DEVICES, IF NEEDED.

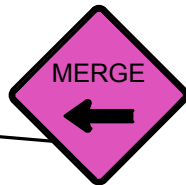

MA-W4-2aL



MA-W20-9



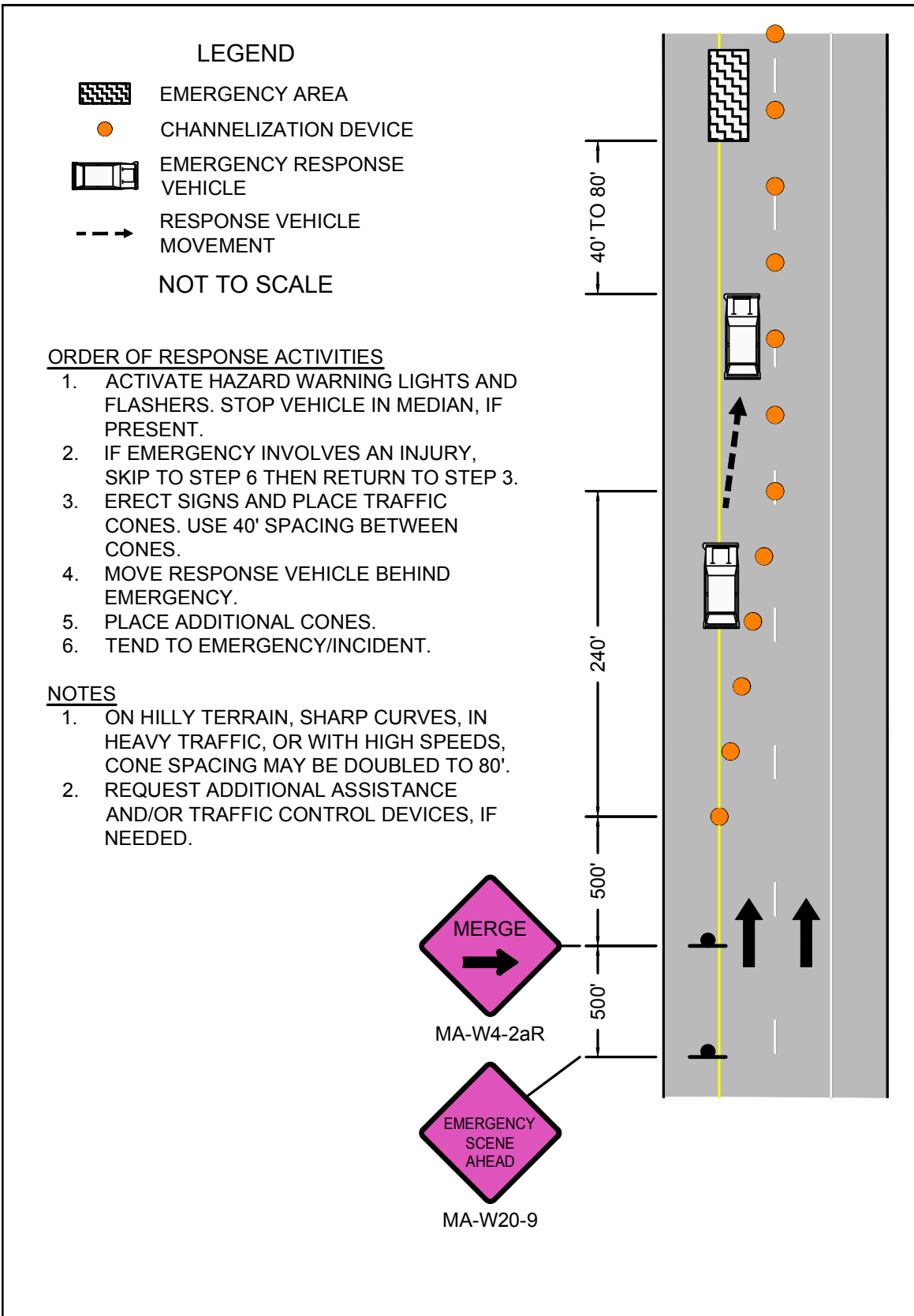
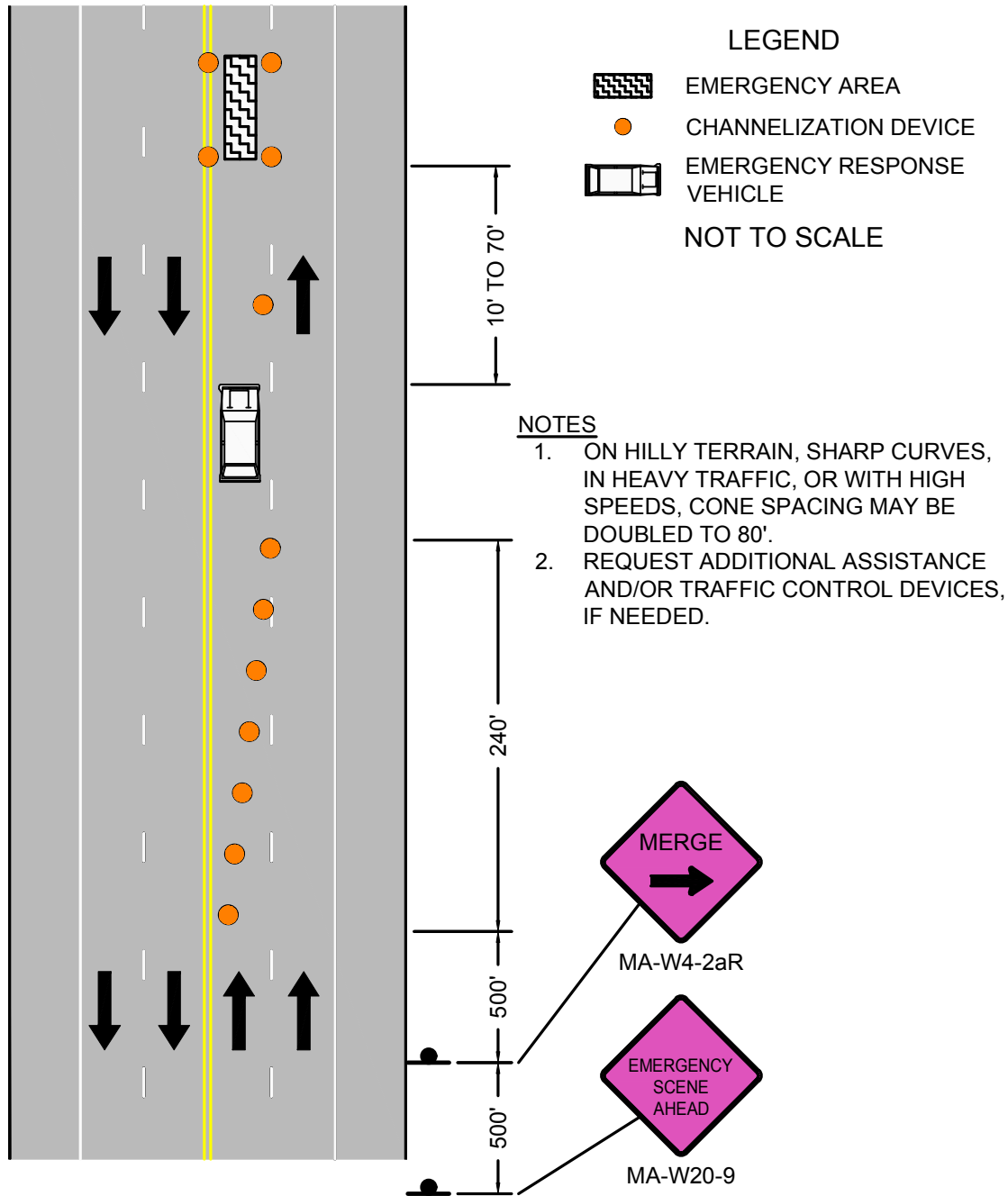

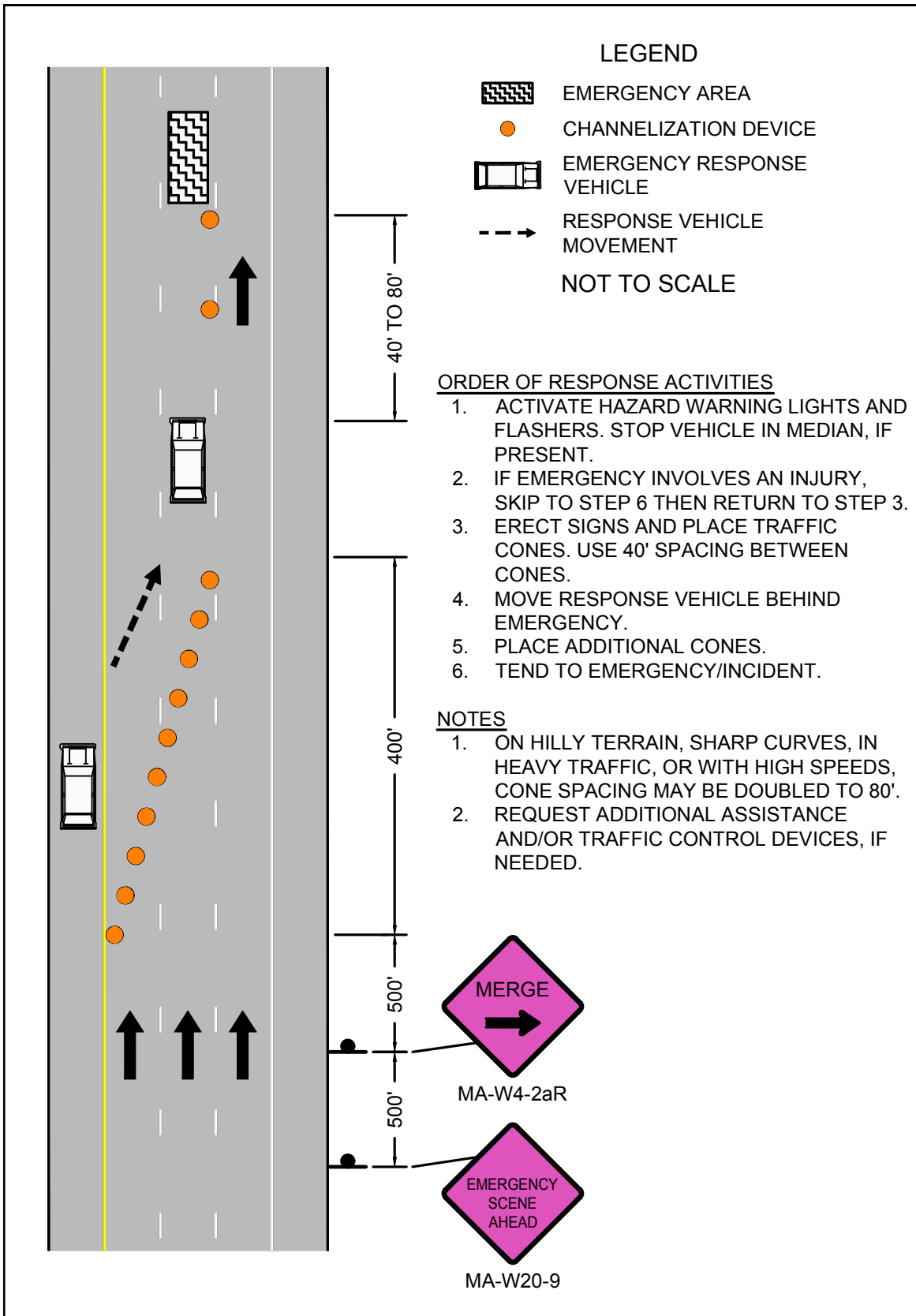

FIGURE 39  
EMERGENCY RESPONSE  
MULTILANE UNDIVIDED  
ROADWAY  
LEFT LANE



**ORDER OF RESPONSE ACTIVITIES**

1. ACTIVATE HAZARD WARNING LIGHTS AND FLASHERS. PULL VEHICLE OVER TO THE RIGHT EDGE OF BREAKDOWN LANE OR SHOULDER OR, IF NOT PRESENT, RIGHT EDGE OF TRAVEL LANE BEFORE STOPPING.
2. IF EMERGENCY INVOLVES AN INJURY, SKIP TO STEP 4 THEN RETURN TO STEP 3.
3. ERECT SIGNS AND PLACE TRAFFIC CONES. USE 40' SPACING BETWEEN CONES.
4. TEND TO EMERGENCY/INCIDENT.







 <p>Massachusetts Department of Transportation Highway Division</p>	<p>Work Zone Safety Standard Details and Drawings</p>	<p><b>FIGURE 40</b> EMERGENCY RESPONSE MULTILANE DIVIDED ROADWAY MIDDLE LANE APPROACH FROM LEFT</p>
--	---	---



FIGURE 41  
EMERGENCY RESPONSE  
MULTILANE DIVIDED ROADWAY  
MIDDLE LANE  
APPROACH FROM RIGHT

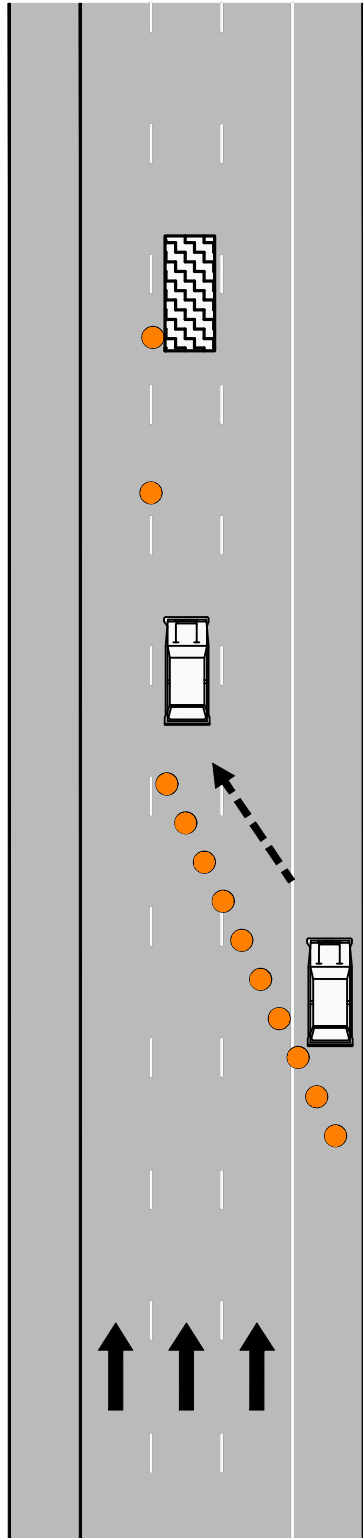

LEGEND

-  EMERGENCY AREA
-  CHANNELIZATION DEVICE
-  EMERGENCY RESPONSE VEHICLE
-  RESPONSE VEHICLE MOVEMENT

NOT TO SCALE

ORDER OF RESPONSE ACTIVITIES

1. ACTIVATE HAZARD WARNING LIGHTS AND FLASHERS. STOP VEHICLE IN BREAKDOWN LANE.
2. IF EMERGENCY INVOLVES AN INJURY, SKIP TO STEP 6 THEN RETURN TO STEP 3.
3. ERECT SIGNS AND PLACE TRAFFIC CONES. USE 40' SPACING BETWEEN CONES.
4. MOVE RESPONSE VEHICLE BEHIND EMERGENCY.
5. PLACE ADDITIONAL CONES.
6. TEND TO EMERGENCY.

NOTES

1. ON HILLY TERRAIN, SHARP CURVES, IN HEAVY TRAFFIC, OR WITH HIGH SPEEDS, CONE SPACING MAY BE DOUBLED TO 80'.
2. REQUEST ADDITIONAL ASSISTANCE AND/OR TRAFFIC CONTROL DEVICES, IF NEEDED.

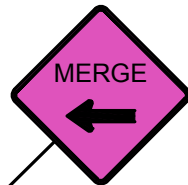



MA-W4-2aL

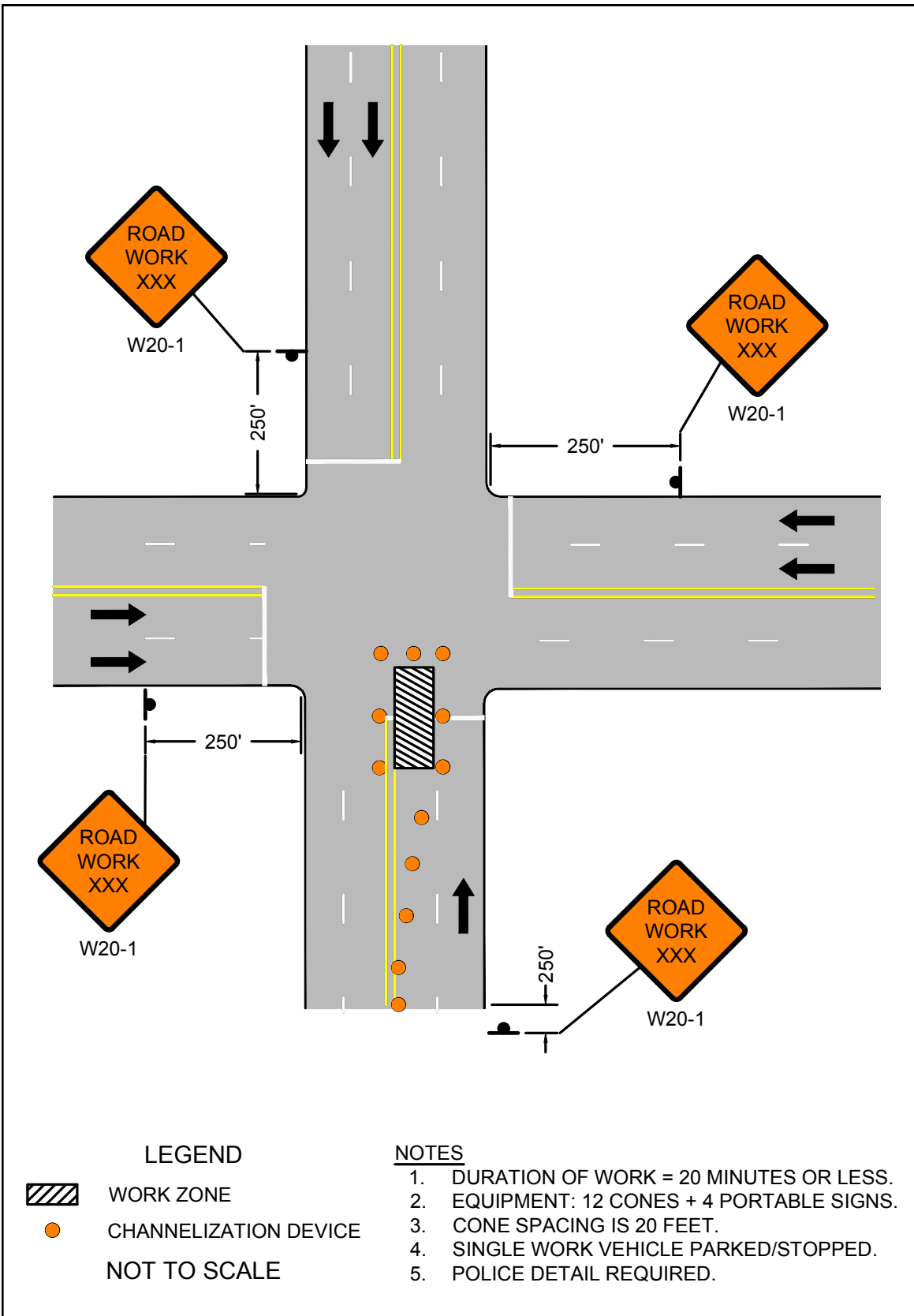

MA-W20-9



**LEGEND**

-  WORK ZONE
-  CHANNELIZATION DEVICE

NOT TO SCALE

**NOTES**

1. DURATION OF WORK = 20 MINUTES OR LESS.
2. EQUIPMENT: 12 CONES + 4 PORTABLE SIGNS.
3. CONE SPACING IS 20 FEET.
4. SINGLE WORK VEHICLE PARKED/STOPPED.
5. POLICE DETAIL REQUIRED.





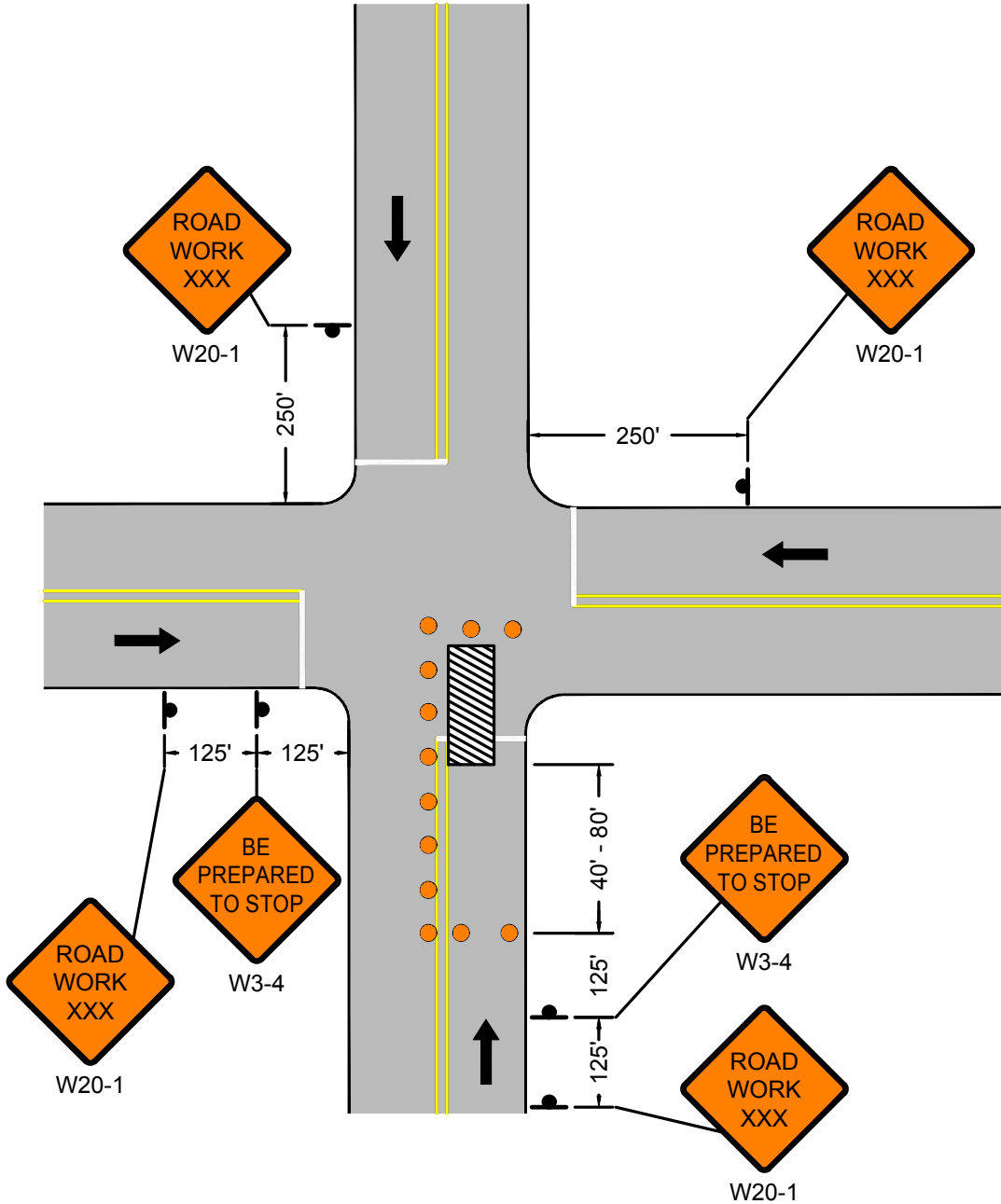

FIGURE 43  
TRAFFIC SIGNAL REPAIR WORK  
TWO LANE UNDIVIDED ROADWAY  
ONE LEG OF INTERSECTION



**LEGEND**

-  WORK ZONE
-  CHANNELIZATION DEVICE
- NOT TO SCALE

**NOTES**

1. DURATION OF WORK = 20 MINUTES OR LESS.
2. EQUIPMENT: 12 CONES + 6 PORTABLE SIGNS.
3. CONE SPACING IS 20 FEET.
4. SINGLE WORK VEHICLE PARKED/STOPPED.
5. POLICE DETAIL REQUIRED.

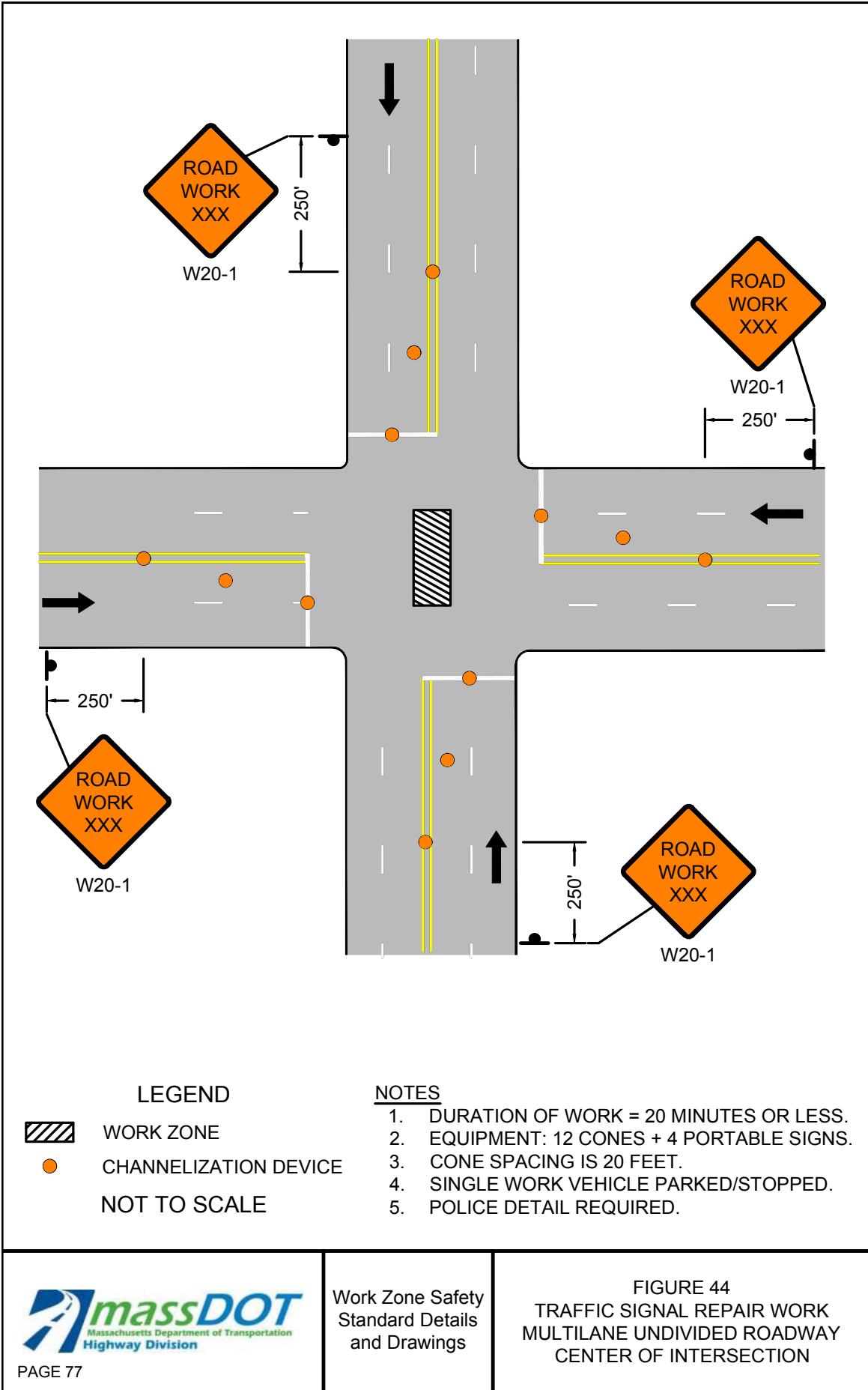



PAGE 78

Work Zone Safety  
Standard Details  
and Drawings

FIGURE 45  
PEDESTRIAN BYPASS

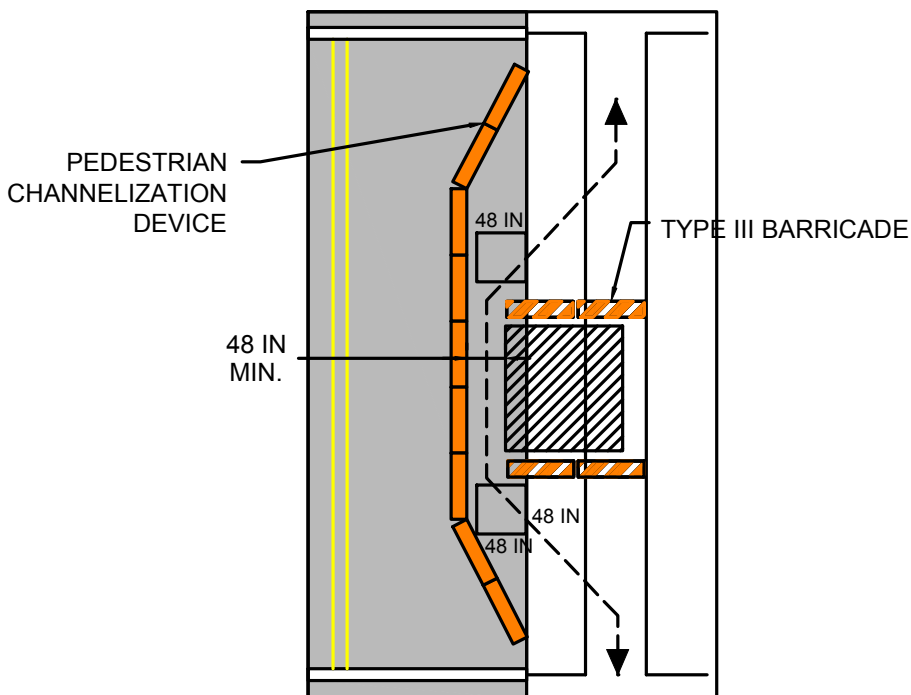

**NOTES:**

1. WHEN EXISTING PEDESTRIAN FACILITIES ARE DISRUPTED, CLOSED, OR RELOCATED IN A TTC ZONE, TEMPORARY FACILITIES SHALL BE PROVIDED AND THEY SHALL BE DETECTABLE AND INCLUDE ACCESSIBILITY FEATURES CONSISTENT WITH THE FEATURES PRESENT IN THE EXISTING PEDESTRIAN FACILITY.
2. A PEDESTRIAN CHANNELIZATION DEVICE THAT IS DETECTABLE BY A PERSON WITH A VISUAL DISABILITY TRAVELING WITH THE AID OF A LONG CANE SHALL BE PLACED ALONG THE FULL LENGTH OF THE TEMPORARY PEDESTRIAN ROUTE.
3. WHEN USED, TEMPORARY RAMPS SHALL COMPLY WITH AMERICANS WITH DISABILITIES ACT.
4. THE ALTERNATE PATHWAY SHOULD HAVE A SMOOTH CONTINUOUS HARD SURFACE FOR THE ENTIRE LENGTH OF THE TEMPORARY PEDESTRIAN FACILITY.
5. THE TEMPORARY SIDEWALK SHOULD BE A MINIMUM OF 4 FEET WIDE. IF THE SIDEWALK EXCEEDS 200 FEET THEN A 5 FOOT BY 5 FOOT PASSING ZONE SHALL BE PROVIDED NEAR THE MID-POINT OF THE CLOSURE.
6. THE PROTECTIVE REQUIREMENTS OF A TTC WORK ZONE MAY HAVE AN IMPACT IN DETERMINING THE NEED FOR TEMPORARY TRAFFIC BARRIERS AND THEIR USE IN PROVIDING PEDESTRIAN DELINEATION SHOULD BE BASED ON ENGINEERING JUDGMENT.
7. ON-DEMAND PEDESTRIAN ASSISTANCE PERSONNEL TO ASSIST WITH NAVIGATION AROUND THE CLOSURE/WORK AREA MAY BE CONSIDERED AS AN OPTION IN PLACE OF PROVIDING ADA/AAB DEVICES FOR WORK FOR CLOSURES LASTING 4 HOURS OR LESS.
8. CONTROLS ONLY FOR PEDESTRIAN TRAFFIC ARE SHOWN; VEHICULAR TRAFFIC SHOULD BE HANDLED AS SHOWN ELSEWHERE. THESE DETAILS ARE USED IN CONJUNCTION WITH THE PROPOSED LANE CLOSURE DETAILS AND DURING CONSTRUCTION STAGING, AS DETERMINED BY THE ENGINEER.



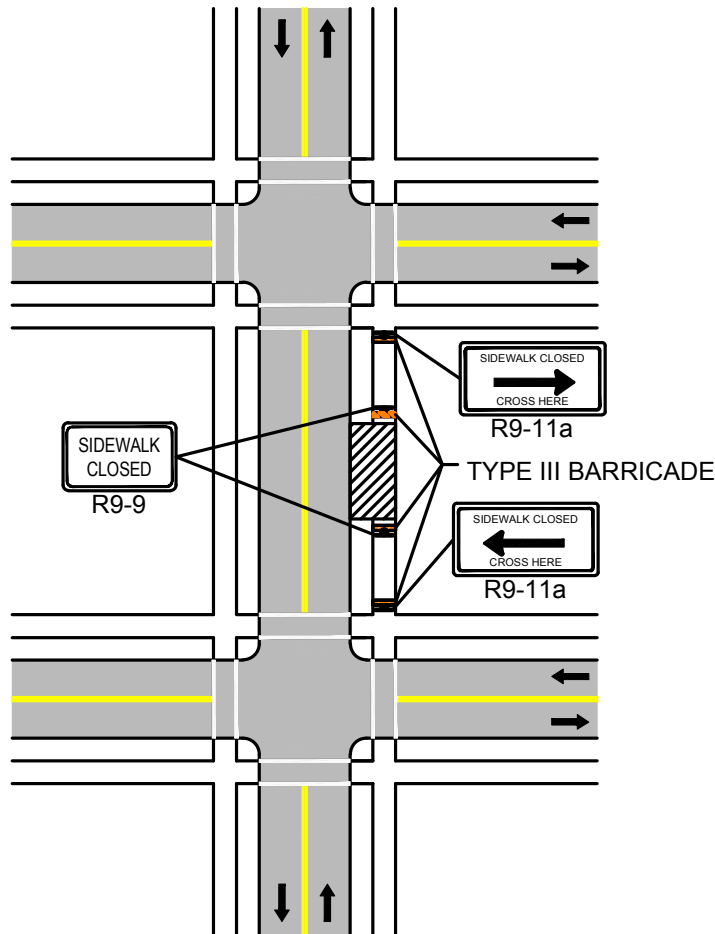

**NOTES:**

1. CLOSURE OF A SIDEWALK FACILITY SHALL CONSTITUTE THE PROVISION FOR MANAGING PEDESTRIAN TRAFFIC AND ACCOMMODATING ALL USERS. IF THE EXISTING PEDESTRIAN ACCESS ROUTE(S) CAN BE TEMPORARILY RELOCATED ALONG THE EXISTING SIDEWALK , AND SAID FACILITY PROVIDES A MINIMUM WIDTH OF 48-INCHES OF SOLID, SMOOTH UNOBSTRUCTED SURFACE, THEN NO DETOURING OF THE ROUTE SHALL BE REQUIRED. DELINEATION OF THE WORK AREA IS STILL REQUIRED.
2. IF IT IS NECESSARY TO DIVERT PEDESTRIAN TRAFFIC TO AN ALTERNATE ROUTE ACROSS THE ROADWAY FROM THE EXISTING FACILITY, THE FIGURE ABOVE SHALL BE FOLLOWED TO PROVIDE ADEQUATE DIRECTION TO PEDESTRIANS. ALTERNATE ROUTE SHALL PROVIDE THE SAME LEVEL OF ACCOMMODATION AS THE FACILITY THAT IS BEING DETOURED AND RETAIN ADA COMPLIANCE IN ITS ENTIRETY.
3. FOR EMERGENCY OR SHORT-DURATION SIDEWALK CLOSURES OF 4-HOURS OR LESS, IT IS OPTIONAL TO HAVE ON-DEMAND PEDESTRIAN ASSISTANCE PERSONNEL AVAILABLE AT ALL TIMES DURING THE CLOSURE TO ASSIST THOSE MOBILITY CHALLENGED PERSONS WHO REQUIRE ADDITIONAL ASSISTANCE TO SAFELY NAVIGATE AROUND THE WORK AREA IN LIEU OF A FULL DETOUR.





PAGE 80

Work Zone Safety  
Standard Details  
and Drawings

STATIONARY OPERATIONS  
BIKE LANE CLOSURE









POSTED SPEED LIMIT (MPH)	SPACING FOR BIKE ADVANCE WARNING SIGNS (FT) (A,B))	CHANNELIZATION DEVICES (DRUMS OR CONES)			
		TRANSITION LENGTH (L/3)	BUFFER ZONE LENGTH (FT)	DEVICE SPACING (FT)	MIN # OF DEVICES*
25-40	150 / 150	100	305	20	45
45-55	150 / 150	220	495	40	35
60-65	150 / 150	260	645	40	40

\* NUMBER OF DEVICES BASED ON 400 FT WORK ZONE.

**NOTES**

1. DETAIL SHALL BE USED IN CONJUNCTION WITH THE PROPOSED LANE CLOSURE DETAILS. SIGNING SHOWN ONLY FOR BIKE TRAFFIC. FOLLOW ALL OTHER RELEVANT DETAILS FOR TTC DEVICES FOR VEHICULAR TRAFFIC.
2. **\*\*** SIGN SHALL BE USED ONLY IF THERE IS A MARKED BIKE LANE.
3. **\*\*\*** SIGN SHALL BE USED ONLY IF THERE IS NO MARKED BIKE LANE.

**LEGEND**

-  WORK ZONE
-  CHANNELIZATION DEVICE
-  FLASHING ARROW BOARD
-  PORTABLE CHANGEABLE MESSAGE SIGN
-  TRUCK MOUNTED ATTENUATOR
-  RADAR SPEED FEEDBACK BOARD
-  POLICE DETAIL OR UNIFORMED FLAGGER
-  TEMPORARY PORTABLE RUMBLE STRIP
-  TYPE III BARRICADE

NOT TO SCALE

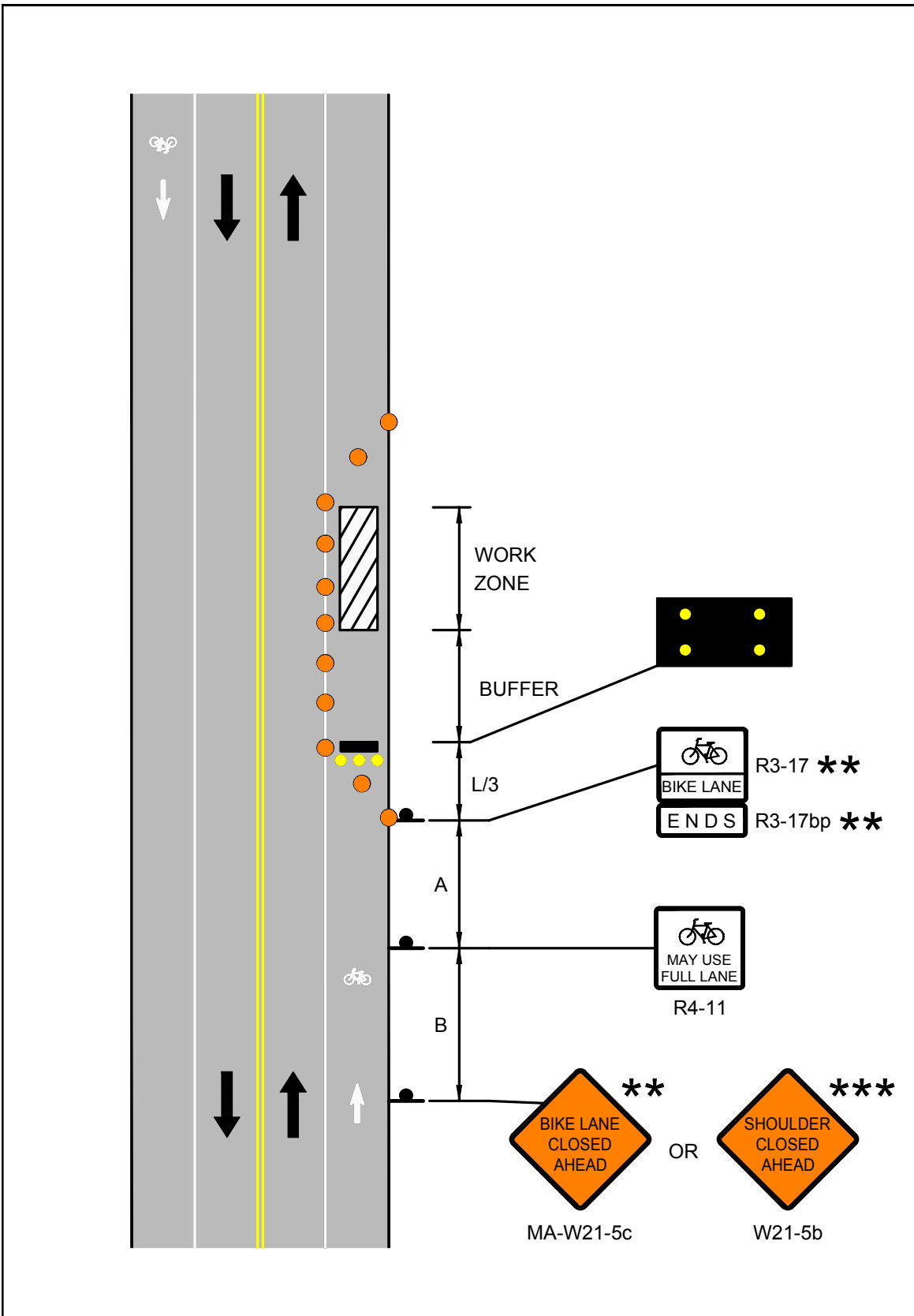

 <p>PAGE 81</p>	<p>Work Zone Safety Standard Details and Drawings</p>	<p>FIGURE 48 STATIONARY OPERATIONS BIKE LANE CLOSURE</p>
--	---	--



**Safety is everyone's business**

Rev. June, 2017

DOCUMENT A00820

**Massachusetts Department of Transportation  
Conditions of Custody**

REQUEST FOR RELEASE OF MASSDOT AUTOCAD FILES FORM

(Only to be used following award of contract)

City/Town: DISTRICT 2 Project File Number: 613740

Contract Number: 128923

Project Description: Scheduled and Emergency Structural Repairs at Various Locations

All AutoCAD files are provided solely as a courtesy to facilitate public access to information. MassDOT attempts to provide current and accurate information but cannot guarantee so. MassDOT provides such documents, files or other data "as is" without any warranty of any kind, either expressed or implied, including but not limited to, accuracy, reliability, omissions, completeness and currentness. The Commonwealth of Massachusetts and its Consultants shall not be liable for any claim for damages, including lost profits or other consequential, exemplary, incidental, indirect or special damages, relating in any way to the documents, files or other data accessible from this file, including, but not limited to, claims arising out of or related to electronic access or transmission of data or viruses. Because data stored on electronic media can deteriorate undetected or be modified without our knowledge, MassDOT cannot be held liable for its completeness or correctness. MassDOT makes no representation as to the compatibility of these files beyond the version of the stated CAD software.

By signing this form, I agree that it shall be my responsibility to reconcile this electronic data with the conformed contract documents, and that only the conformed contract documents shall be regarded as legal documents for this Project. I understand that this authorization does not give me the right to distribute the files. I agree to the terms above and wish to receive the AutoCAD files.

This signed form shall be emailed to the Highway Design Engineer at the MassDOT -Highway Division at the following email address:

[DOTHighwayDesign@dot.state.ma.us](mailto:DOTHighwayDesign@dot.state.ma.us)

Attn: AutoCAD Files

Name of person requesting AutoCAD files: \_\_\_\_\_

Affiliation/Company: \_\_\_\_\_

Address: \_\_\_\_\_

Telephone number: \_\_\_\_\_

Email address: \_\_\_\_\_

Signature/Date: \_\_\_\_\_

THIS PAGE IS INTENTIONALLY LEFT BLANK

DOCUMENT A00875

**POLICY DIRECTIVE P-22-001  
AND  
POLICY DIRECTIVE P-22-002**

THIS PAGE INTENTIONALLY LEFT BLANK





Number:           P-22-001            
Date:           9/23/22          

# **POLICY DIRECTIVE**

Jonathan Gulliver (signature on original)  
\_\_\_\_\_  
HIGHWAY ADMINISTRATOR

## **Off-Site Stockpiling of Soil from MassDOT Construction Projects**

### **Purpose**

The purpose of this Policy Directive is to formally establish a policy and procedures for managing and stockpiling soil generated and transported from MassDOT construction projects. This Policy Directive does not supersede any Federal, State, or Local regulations.

### **Date of Effect**

This Policy Directive is effective immediately for all projects, including active construction projects.

For active construction projects and for other projects advertised prior to October 15, 2022, changes to the contract documents needed to implement the requirements of this Policy Directive will be considered on a case-by-case basis and shall be approved by the District Highway Director, as necessary.

For projects advertised on or after October 15, 2022, MassDOT will include the requirements and implementation procedures of this Policy Directive in the construction contract documents.

### **Policy Requirements**

This policy is intended to prevent the off-site relocation of excavated soil generated from MassDOT projects to areas near residential receptors and to control potential fugitive dusts and/or contaminants. To that end, excavated soil may not be moved from the project site without knowledge of the content of the material. Knowledge may include visual field observations for presence of staining, odor, and/or debris, screening with a photoionization detector (PID), laboratory analysis, and/or site history. Pavement millings and other non-soil materials are not subject to the requirements of this Policy Directive.

Moving soil from a MassDOT project site to a temporary off-site storage location must be approved in writing by the District Highway Director.

The Contractor must select a storage location that is at least 500 feet away from residential receptors, as defined herein to include, but not be limited to, residential dwellings, residentially

zoned property, schools, daycare facilities, playgrounds, parks, recreational areas, hospitals, elderly housing and convalescent facilities.

Temporary off-site storage of excavated soil from a MassDOT project is only permissible at a location approved and permitted by MassDOT. The temporary storage location should be located within the same municipality where the soil was excavated, where possible. Stockpiled soil must be securely covered, and appropriate measures must be taken to minimize fugitive dust and erosion.

Signs indicating the source of the soil, the date the soil was generated, and contact information must be erected and maintained until the stockpiled soils are transported to a disposal facility or reused on the project site.

### **Implementation Procedures**

To ensure that off-site storage of excavated soils is managed properly on MassDOT projects, this policy requires the following:

#### **1. Off-Site Stockpile Storage Locations**

- a. The Contractor shall provide proposed off-site storage locations to the Engineer for approval at least 30 days prior to transporting soil off site. Off-site storage locations should be in the same municipality as the work site.
- b. The Contractor shall keep excavated soil on site until adequately characterized to the satisfaction of the Engineer.
- c. The Contractor shall provide notification of the approved off-site storage location to the local Board of Health and the Town Manager's/Mayor's Office at least 7-days prior to transporting soil off site.
- d. The Contractor shall provide the Engineer with at least 3-days' notice prior to transporting soil off site.
- e. For off-site storage locations on MassDOT property, the Contractor is required to obtain an Access Permit through the District Permits Office prior to storage of soil or other materials. MassDOT will issue these permits at no cost to the Contractor. Information to be submitted by the Contractor as part of the permit application shall include:
  - i. A description of material to be stored off-site, including available analytical data;
  - ii. A figure of the location with distances to residences and residential receptors; and
  - iii. Anticipated duration of temporary storage.
- f. Stockpile locations should not be within 500 feet of residential receptors (e.g., residential dwellings, residentially zoned property, schools, daycare facilities, playgrounds, parks, recreational areas, hospitals, elderly housing and convalescent facilities).
  - i. If the stockpile location must be within 500 feet of residential receptors, then soil must be less than RCS-1 (per 310 CMR 40.1600) and free of potentially hazardous or regulated items.

- g. For off-site storage locations on non-MassDOT property, the Contractor must notify the property owner(s) at least 7 days prior to transporting material.
- h. Exceptions to these rules will be reviewed by MassDOT and may be approved by the District Highway Director on a case-by-case basis.

## **2. Off-Site Stockpile Management**

- a. The Contractor shall keep soil stockpiles on impermeable surfaces (e.g., asphalt or concrete) or on 10-mil polyethylene sheeting.
- b. The Contractor shall cover soil stockpiles with 10-mil polyethylene sheeting and surround with a berm made of hay bales, straw wattles, or similar.
  - i. Piles that are actively being worked on must be covered and re-secured at the end of the work shift.
- c. The Contractor shall label stockpiles with signs, including:
  - i. Location of origin (including any Release Tracking Numbers)
  - ii. Stockpile ID number (including MassDOT District office-assigned tracking ID, if different)
  - iii. Date of initial accumulation
  - iv. Applicable telephone numbers for the Contractor and MassDOT.
- d. The Contractor shall mitigate fugitive dust at storage locations under the direction of an appropriately trained/certified environmental professional.
- e. The Contractor shall remedy noncompliance with this policy within 48 hours.
- f. The Contractor shall remedy noncompliance with this policy on the SAME DAY for potentially hazardous material, as determined by the Engineer.
- g. The Contractor shall handle excavated soil according to federal, state, and local regulations.
- h. The Contractor shall use appropriate shipping documents for all movements of excavated soil on public roadways (e.g., Bill of Lading, Material Shipping Record, Manifest, Asbestos Waste Shipment Record, etc.).

THIS PAGE INTENTIONALLY LEFT BLANK



Number:           P-22-002            
Date:           9/23/22          

# **POLICY DIRECTIVE**

Jonathan Gulliver (signature on original)  
\_\_\_\_\_  
HIGHWAY ADMINISTRATOR

## **Use of MassDOT Property for Staging and other Construction-Related Operations**

### **Purpose**

This Policy Directive is intended to address the use of MassDOT property by MassDOT Contractors for construction staging and other construction-related operations that are not specifically defined in the construction contract. Such use of MassDOT property will only be allowed if permitted by the District Office in accordance with 700 CMR 13.00, Approval of Access to MassDOT Highways and Other Property. This includes the use of MassDOT property for staging, laydown, and storage of equipment and materials, including soil excavated from a project site.

This Policy Directive requires the Contractor/applicant to obtain a Non-Vehicular Access Permit from MassDOT to use MassDOT property for these purposes.

This Policy Directive is effective immediately and applies to all MassDOT construction projects.

### **General Permit Considerations and Conditions**

In addition to other normal MassDOT Access Permit procedures, MassDOT shall consider the following during the application, review, implementation and monitoring processes of Access Permits required by this Policy Directive:

- Storage and placement of the Contractor’s equipment and materials should not be allowed within the clear zone of the roadway.
- Stockpiled soils should not be located within 500 feet of residential receptors, as defined herein to include, but not be limited to, residential dwellings, residentially zoned property, schools, daycare facilities, playgrounds, parks, recreational areas, hospitals, elderly housing and convalescent facilities.
- The Contractor/applicant shall identify the access/egress locations of the proposed storage areas. MassDOT will only approve locations determined to be safe for roadway users, construction workers and the general public.
- The Contractor may be required to submit a Traffic Management Plan and/or Lighting Plan for MassDOT review and approval as part of the permit application, depending on the proposed use of the area.

- The Contractor shall submit the permit application through MassDOT's online State Highway Access Permit System (SHAPS).
- MassDOT will waive the permit application fee for any application received from a MassDOT Contractor for any permit required by this Policy Directive and will waive any subsequent amendment and extension fees that may otherwise be required.
- MassDOT will review the permit application in accordance with applicable standard procedures and will apply standard permit terms and conditions, as necessary.
- The Resident Engineer will verify that the permit is approved before allowing the Contractor to use the affected area for the requested purpose.
- Areas permitted are for use by the approved applicant only and are not to be shared with or used by other vendors. Subcontractors specifically engaged with the applicant working on the specific MassDOT project will be allowed to use the area in accordance with the terms of the permit.
- Permits are issued on an annual basis and will require the Contractor to file for an extension each year to continue use.

### **Exemptions from Permit Requirements**

Equipment and materials being used for active construction operations and located within the work zone of the construction contract are exempt from this permit requirement, provided they do not interfere with the safety or operation of the roadway or the work zone. Examples of these types of exempt uses are:

- Equipment and materials parked or stored within a protected (barriered) work zone.
- Materials placed in the work zone prior to same-day installation or use.
- Soils excavated temporarily and scheduled to be replaced, such as for trenching operations or for installation of drainage structures.

DOCUMENT B00420

PROPOSAL

DISTRICT 2

For: **Scheduled and Emergency Structural Repairs at Various Locations**

COMMONWEALTH OF MASSACHUSETTS

LOCATION

The work referred to herein is in the Cities and Towns of DISTRICT 2 in Franklin, Hampden, Hampshire, and Worcester Counties, in the Commonwealth of Massachusetts, and is shown by the locus map (Document 00331) in the Proposal Pamphlet, the work locations extend as follows:

**at Various Locations**

The contract prices shall include the furnishing of all materials (except as otherwise herein specified), the performing of all the labor requisite or proper, the providing of all necessary machinery, tools, apparatus and other means of construction, the doing of all the abovementioned work in the manner set forth, described and shown in the specifications and on the drawings for the work, and in the form of contract, and the completion thereof within **730 CALENDAR DAYS** upon receipt of a Notice to Proceed, except that if the completion date falls between December 1 and March 15 then the same number of days beyond December 1st will be extended after March 15<sup>th</sup>.

The Work of this project is described by the following Items and quantities.

THIS PAGE INTENTIONALLY LEFT BLANK





Project # 613740		Contract # 128923		
Location : DISTRICT2				
Description : Scheduled and Emergency Structural Repairs at Various Locations				
ITEM #	QUANTITY	ITEM WITH UNIT BID PRICE WRITTEN IN WORDS	UNIT PRICE	AMOUNT
100.1	3,750	BASE LABOR RATE  AT _____ PER HOUR		
102.21	25	SELECTIVE CLEARING AND GRUBBING  AT _____ PER SQUARE YARD		
106.15	2	BLEEDER (BRIDGE DECK) PVC  AT _____ EACH		
106.151	15	PVC DRAINPIPE EXTENSIONS  AT _____ EACH		
106.88	6	JACKING AND SHORING  AT _____ EACH		
106.881	3	JACKING AND SHORING REMOVED AND RESET  AT _____ EACH		
107.97	12,050	STRUCTURAL STEEL REPAIRS  AT _____ PER POUND		
127.1	15	REINFORCED CONCRETE EXCAVATION  AT _____ PER CUBIC YARD		
748.1	2	EMERGENCY RESPONSE  AT _____ EACH		

Project # 613740		Contract # 128923		
Location : DISTRICT2				
Description : Scheduled and Emergency Structural Repairs at Various Locations				
ITEM #	QUANTITY	ITEM WITH UNIT BID PRICE WRITTEN IN WORDS	UNIT PRICE	AMOUNT
851.1	80	TRAFFIC CONES FOR TRAFFIC MANAGEMENT  AT _____ PER DAY		
852.	384	SAFETY SIGNING FOR TRAFFIC MANAGEMENT  AT _____ PER SQUARE FOOT		
853.403	100	TRUCK MOUNTED ATTENUATOR  AT _____ PER DAY		
853.8	10	TEMPORARY ILLUMINATION FOR WORK ZONE  AT _____ PER DAY		
854.016	500	TEMPORARY PAVING MARKINGS - 6 INCH (PAINTED)  AT _____ PER FOOT		
854.036	500	TEMPORARY PAVING MARKINGS - 6 INCH (TAPE)  AT _____ PER FOOT		
854.1	500	PAVEMENT MARKING REMOVAL  AT _____ PER SQUARE FOOT		
854.6	60	TEMPORARY PORTABLE RUMBLE STRIP  AT _____ PER DAY		
856.	100	ARROW BOARD  AT _____ PER DAY		

Project # 613740		Contract # 128923		
Location : DISTRICT2				
Description : Scheduled and Emergency Structural Repairs at Various Locations				
ITEM #	QUANTITY	ITEM WITH UNIT BID PRICE WRITTEN IN WORDS	UNIT PRICE	AMOUNT
856.12	100	PORTABLE CHANGEABLE MESSAGE SIGN  AT _____ PER DAY		
859.	2,500	REFLECTORIZED DRUM  AT _____ PER DAY		
859.1	50	REFLECTORIZED DRUMS WITH SEQUENTIAL FLASHING WARNING LIGHTS  AT _____ PER DAY		
866.206	500	6 INCH REFLECTORIZED WHITE LINE (POLYUREA) (RECESSED)  AT _____ PER FOOT		
867.206	500	6 INCH REFLECTORIZED YELLOW LINE (POLYUREA) (RECESSED)  AT _____ PER FOOT		
905.	15	4000 PSI, 3/8 INCH, 660 CEMENT CONCRETE  AT _____ PER CUBIC YARD		
910.1	750	STEEL REINFORCEMENT FOR STRUCTURES - EPOXY COATED  AT _____ PER POUND		
961.211	1,305	CLEAN (FULL REMOVAL) AND PAINT - STRUCTURAL STEEL  AT _____ PER SQUARE FOOT		
994.1	300	TEMPORARY PROTECTIVE SHIELDING  AT _____ PER SQUARE FOOT		
<b>Total Qty:</b>		24,122		

THIS PAGE INTENTIONALLY LEFT BLANK

DOCUMENT B00842

SCHEDULE OF PARTICIPATION  
BY MINORITY OR WOMEN BUSINESS ENTERPRISES (M/WBE)

MASSDOT PROJECT NUMBER: 613740

PROJECT LOCATION: DISTRICT 2

DATE OF BID OPENING: \_\_\_\_\_

NAME OF PRIME BIDDER: \_\_\_\_\_

Name Address and Phone Number of M/WBE	Name of Activity	(a) M/WBE Contractor Activity Amount	(b) M/WBE Other Business Amount	(c) Total amount eligible for credit under rules in Section VIII of the Special Provisions
Total Bid Amount	TOTALS:	\$		\$
\$	M/WBE Percentage of Total bid:		%	%

Column (a) must be at least one-half of the M/WBE percentage goal.

SIGNATURE: \_\_\_\_\_ Date: \_\_\_\_\_ Tel No: \_\_\_\_\_

NAME AND TITLE (PRINT): \_\_\_\_\_

BIDDERS ARE CAUTIONED TO REVIEW DOCUMENT 00718 -- SPECIAL PROVISION FOR PARTICIPATION BY MINORITY OR WOMEN BUSINESS ENTERPRISES AND SERVICE DISABLED VETERAN OWNED BUSINESS ENTERPRISES.

\*\*\* END OF DOCUMENT \*\*\*

THIS PAGE IS INTENTIONALLY LEFT BLANK.

DOCUMENT B00843

MINORITY OR WOMEN'S BUSINESS ENTERPRISE PARTICIPATION LETTER OF INTENT  
PAGE 1 OF 2

MASSDOT PROJECT NUMBER: 613740 \_\_\_\_\_

PROJECT LOCATION: DISTRICT 2 \_\_\_\_\_

DATE OF BID OPENING: \_\_\_\_\_

FROM \_\_\_\_\_  
(Minority or Women's Business Enterprise Company)

TO: \_\_\_\_\_  
(Name of Prime Contractor)

1. My company is currently certified as an MBE or WBE by the Massachusetts Supplier Diversity Office, formerly known as the State Office of Minority and Women Business Assistance (SOMWBA). There have been no changes affecting the ownership, control or independence of my company since my last certification review.
2. If any such change occurs prior to my company's completion of this proposed work, I will give written notification to your firm and to the Massachusetts Department of Transportation (MassDOT).
3. (For contractor activity only.) My firm will provide to you, upon request, for the purpose of obtaining subcontractor approval from MassDOT; (1) a resume stating the qualifications and experience of the superintendent or foreperson who will supervise on site-work; (2) a list of equipment owned or leased by my firm for use on the project; (3) a list of all projects (public or private) which my firm is currently performing, is committed to perform, or intends to make a commitment to perform. I shall include, for each project, the names and telephone number of a contact person for the contracting organization, the dollar value of the work, a description of the work, and my firm's work schedule for the Project.
4. If you are awarded the Contract, my company intends to enter into an agreement with your firm to perform the items of work or other activity described on the following sheet for the prices indicated.
5. My firm has the ability to manage, supervise and perform the activity described on the following page.

\_\_\_\_\_  
M/WBE Authorized Signature

\_\_\_\_\_  
Date

MINORITY OR WOMEN'S BUSINESS ENTERPRISE PARTICIPATION LETTER OF INTENT  
PAGE 2 OF 2

MASSDOT PROJECT NUMBER: 613740

PROJECT LOCATION: DISTRICT 2

DATE OF BID OPENING: \_\_\_\_\_

NAME OF PRIME BIDDER: \_\_\_\_\_

<u>Item number</u> if applicable	<u>Description of Activity</u> with notations such as Installation Only, Material Only, or Complete	<u>Quantity</u>	<u>Unit Price</u>	<u>Amount</u>
TOTAL AMOUNT:				

M/WBE COMPANY NAME: \_\_\_\_\_

M/WBE AUTHORIZED SIGNATURE: \_\_\_\_\_

NAME AND TITLE (PRINT): \_\_\_\_\_

TELEPHONE NUMBER: \_\_\_\_\_ FAX NUMBER: \_\_\_\_\_

\*\*\* END OF DOCUMENT \*\*\*

Rev'd 9/20/19



DOCUMENT B00846

M/WBE OR SDVOBE JOINT CHECK ARRANGEMENT APPROVAL FORM

(to be submitted by Prime Contractor)

Contract No: 128923 Project No. 613740

Location: DISTRICT 2 Bid Opening Date: \_\_\_\_\_

Project Description: Scheduled and Emergency Structural Repairs at Various Locations

We have received the attached request for the use of a joint check arrangement from \_\_\_\_\_, a M/WBE or SDVOBE on the above- referenced Contract and \_\_\_\_\_, a Material Supplier/Vendor for the subject Contract. The M/WBE or SDVOBE has complied with the requirements of Special Provision Document 00718. In particular, the M/WBE or SDVOBE has:

- a written agreement with the material supplier/vendor;
- applied for credit with the subject material supplier and has supplied the vendor's response;
- shown that it will place all orders to the subject material supplier/vendor;
- made and retains all decision-making responsibilities concerning the materials; and
- provided a Joint Check Agreement that is acceptable to MassDOT;

As the Contractor for the Project, we agree to issue joint checks (made payable to the Material Supplier/Vendor and the M/WBE or SDVOBE) for payment of sums due pursuant to invoices from the Supplier/Vendor and M/WBE or SDVOBE.

**Contractor:**

\_\_\_\_\_  
Company Name

\_\_\_\_\_  
Signature  
Duly Authorized

\_\_\_\_\_  
Printed Name

\_\_\_\_\_  
Date

\_\_\_\_\_  
Title

**SubContractor:**

\_\_\_\_\_  
Company Name

\_\_\_\_\_  
Signature –  
Duly Authorized

\_\_\_\_\_  
Printed Name

\_\_\_\_\_  
Date

\_\_\_\_\_  
Title

\*\*\* END OF DOCUMENT \*\*\*

THIS PAGE INTENTIONALLY LEFT BLANK

DOCUMENT B00847

JOINT VENTURE AFFIDAVIT  
(All Firms)

- All Information Requested By This Schedule Must Be Answered. Additional Sheets May Be Attached.
- If, there is any change in the information submitted, the Joint Venture parties must inform MassDOT Pre-Qualifications Office (and, if one of the companies is a M/WBE or SDVOBE, the Director of Contract Compliance, Office of Civil Rights) *prior* to such change, in writing, either directly or through the Prime Contractor if the Joint Venture is a subcontractor.
- If the Joint Venture Entity will be the bidder on a prime Contract, it must bid and submit all required documents (insurance, worker’s compensation, bonds, etc.) in the name of the Joint Venture Entity.

**I. Name of Joint Venture:** \_\_\_\_\_  
 Type of Entity if applicable (Corp., LLC): \_\_\_\_\_ Filing State \_\_\_\_\_  
 Address of joint venture: \_\_\_\_\_  
 \_\_\_\_\_  
 Phone No(s) for JV Entity: \_\_\_\_\_ E-mail: \_\_\_\_\_  
 Contact Person(s) \_\_\_\_\_  
 Tax ID/EIN of Joint Venture: \_\_\_\_\_ Vendor Code: \_\_\_\_\_

**II. Identify each firm or party to the Joint Venture:**  
 Name of Firm: \_\_\_\_\_  
 Address: \_\_\_\_\_  
 Phone : \_\_\_\_\_ E-mail: \_\_\_\_\_  
 Contact person(s) \_\_\_\_\_  
 Name of Firm: \_\_\_\_\_  
 Address: \_\_\_\_\_  
 Phone: \_\_\_\_\_ E-mail: \_\_\_\_\_  
 Contact Person(s) \_\_\_\_\_

**III. Describe the role(s) of the each party to the Joint Venture:**  
 \_\_\_\_\_  
 \_\_\_\_\_

**IV. Attach a copy of the Joint Venture Agreement.** The proposed Joint Venture Agreement should include specific details including, but not limited to: (1) the contributions of capital and equipment; (2) work items to be performed by each company’s forces, (3) work items to be performed under the supervision of any M/WBE or SDVOBE Venturer; (4) the commitment of management, supervisory and operative personnel employed by the M/WBE or SDVOBE to be dedicated to the performance of the Project; and (5) warranty, guaranty, and indemnification clauses.

**V. Attach any applicable Corporate or LLC Votes, Authorizations, etc.**

**VI. Ownership of the Joint Venture:**

A. What is the percentage(s) of each company's ownership in the Joint Venture?

ownership percentage(s): \_\_\_\_\_

ownership percentage(s): \_\_\_\_\_

B. Specify percentages for each of the following (provide narrative descriptions and other detail as applicable):

1. Sharing of profit and loss: \_\_\_\_\_

2. Capital contributions:

(a) Dollar amounts of initial contribution: \_\_\_\_\_

(b) Dollar amounts of anticipated on-going contributions: \_\_\_\_\_

(c) Contributions of equipment (specify types, quality and quantities of equipment to be provided by each firm): \_\_\_\_\_

4. Other applicable ownership interests, including ownership options or other agreements, which restrict or limit ownership and/or control:

5. Provide copies of all other written agreements between firms concerning bidding and operation of this Project or projects or contracts.

6. Identify all current contracts and contracts completed during the past two (2) years by either of the Joint Venture partners to this Joint Venture:

**VII. Control of and Participation in the Joint Venture.** Identify by name and firm those individuals who are, or will be, responsible for and have the authority to engage in the following management functions and policy decisions. (Indicate any limitations to their authority such as dollar limits and co-signatory requirements.):

A. Joint Venture check signing:

\_\_\_\_\_  
\_\_\_\_\_

B. Authority to enter Contracts on behalf of the Joint Venture:

\_\_\_\_\_  
\_\_\_\_\_

C. Signing, co-signing and/or collateralizing loans:

\_\_\_\_\_  
\_\_\_\_\_

D. Acquisition of lines of credit:

\_\_\_\_\_

\_\_\_\_\_

E. Acquisition and indemnification of payment and performance bonds:

\_\_\_\_\_

\_\_\_\_\_

F. Negotiating and signing labor agreements:

\_\_\_\_\_

\_\_\_\_\_

G. Management of contract performance. (*Identify by name and firm only*):

1. Supervision of field operations: \_\_\_\_\_
2. Major purchases: \_\_\_\_\_
3. Estimating: \_\_\_\_\_
4. Engineering: \_\_\_\_\_

**VIII. Financial Controls of Joint Venture:**

A. Which firm and/or individual will be responsible for keeping the books of account?

\_\_\_\_\_

\_\_\_\_\_

B. Identify the "Managing Partner," if any, and describe the means and measure of their compensation:

\_\_\_\_\_

\_\_\_\_\_

C. What authority does each firm have to commit or obligate the other to insurance and bonding companies, financing institutions, suppliers, subcontractors, and/or other parties participating in the performance of this Contract or the work of this Project?

\_\_\_\_\_

**IX. Personnel of Joint Venture:** State the approximate number of personnel (by trade) needed to perform the Joint Venture's work under this Contract. Indicate whether they will be employees of the majority firm, M/WBE or SDVOBE firm, or the Joint Venture.

	Firm 1 (number)	Firm 2 (number)	Joint Venture (number)
Trade			
Professional			
Administrative/Clerical			
Unskilled Labor			

Will any personnel proposed for this Project be employees of the Joint Venture?: \_\_\_\_\_

If so, who: \_\_\_\_\_

A. Are any proposed Joint Venture employees currently employed by either firm?

Employed by Firm 1: \_\_\_\_\_ Employed by firm 2 \_\_\_\_\_

B. Identify by name and firm the individual who will be responsible for Joint Venture hiring: \_\_\_\_\_

\_\_\_\_\_

**X. Additional Information.** Please state any material facts and additional information pertinent to the control and structure of this Joint Venture.

\_\_\_\_\_  
\_\_\_\_\_

**XI. AFFIDAVIT OF JOINT VENTURE PARTIES.** The undersigned affirm that the foregoing statements and attached documents are correct and include all material information necessary to identify and explain the terms and operations of our Joint Venture and the intended participation of each firm in the undertaking. Further, the undersigned covenant and agree to provide to MassDOT current, complete and accurate information regarding actual Joint Venture work, payments, and any proposed changes to any provisions of the Joint Venture, or the nature, character of each party to the Joint Venture. We understand that any material misrepresentation will be grounds for terminating any Contract awarded and for initiating action under Federal or State laws concerning false statements.

\_\_\_\_\_  
Firm 1

\_\_\_\_\_  
Firm 2

\_\_\_\_\_  
Signature  
Duly Authorized

\_\_\_\_\_  
Signature  
Duly Authorized

\_\_\_\_\_  
Printed Name and Title

\_\_\_\_\_  
Printed Name and Title

\_\_\_\_\_  
Date

\_\_\_\_\_  
Date

\*\*\* END OF DOCUMENT \*\*\*