

COMMONWEALTH OF MASSACHUSETTS



**CONTRACT DOCUMENTS
AND SPECIAL PROVISIONS**

PROPOSAL NO.	612097-129070
P.V. =	\$7,903,000.00
PLANS	NO

FOR

Federal Aid Project No. NHP(IM)/HIP(BR)-0912(310)X

Pavement and Bridge Preservation on I-91

in the Cities of

WEST SPRINGFIELD - CHICOPEE

In accordance with the STANDARD SPECIFICATIONS
for HIGHWAYS and BRIDGES dated 2024

This Proposal to be opened and read:

TUESDAY, JANUARY 28, 2025 at 2:00 P.M.

THIS PAGE IS INTENTIONALLY LEFT BLANK

DOCUMENT 00010

TABLE OF CONTENTS

DOCUMENT 00010
TABLE OF CONTENTS 00010-1 through 4

DOCUMENT 00104
NOTICE TO CONTRACTORS 00104- 1 through 4

DOCUMENT 00210
REQUIREMENTS OF MASSACHUSETTS GENERAL
LAWS CHAPTER 30 SECTION 39R; CHAPTER 30, SECTION 39O 00210-1 through 4

DOCUMENT 00331
LOCUS MAP 00331-1 through 2

DOCUMENT 00439
CONTRACTOR PROJECT EVALUATION FORM 00439-1 through 2

DOCUMENT 00440
SUBCONTRACTOR PROJECT EVALUATION FORM 00440-1 through 2

DOCUMENT 00710
GENERAL CONTRACT PROVISIONS..... 00710-1 through 2

DOCUMENT 00712
SUPERPAVE HIGH PERFORMANCE SURFACE COURSE 00712-1 through 16

DOCUMENT 00713
SUBSECTION 701
CEMENT CONCRETE SIDEWALKS, PEDESTRIAN CURB RAMPS, AND DRIVEWAYS
AND GUIDE TO THE INTERIM SUBSECTION 701
CEMENT CONCRETE SIDEWALK SPECIFICATION..... 00713-1 through 34

DOCUMENT 00714
SUPERPAVE WATERPROOFING SURFACE COURSE..... 00714-1 through 16

DOCUMENT 00715
SUPPLEMENTAL SPECIFICATIONS 00715-1 through 24

DOCUMENT 00719
SPECIAL PROVISIONS FOR PARTICIPATION BY DISADVANTAGED
BUSINESS ENTERPRISES 00719-1 through 18

DOCUMENT 00760
REQUIRED CONTRACT PROVISIONS FOR FEDERAL-AID
CONSTRUCTION CONTRACTS..... 00760-1 through 14

DOCUMENT 00811
MONTHLY PRICE ADJUSTMENT FOR HOT MIX ASPHALT
(HMA) MIXTURES..... 00811-1 through 2

DOCUMENT 00812
MONTHLY PRICE ADJUSTMENT FOR DIESEL FUEL AND GASOLINE 00812-1 through 2

DOCUMENT 00813
PRICE ADJUSTMENT FOR STRUCTURAL STEEL
AND REINFORCING STEEL 00813-1 through 4

TABLE OF CONTENTS (Continued)

DOCUMENT 00814
PRICE ADJUSTMENT FOR PORTLAND CEMENT CONCRETE MIXES 00814-1 through 2

DOCUMENT 00820
THE COMMONWEALTH OF MASSACHUSETTS
SUPPLEMENTAL EQUAL EMPLOYMENT OPPORTUNITY,
NON-DISCRIMINATION AND AFFIRMATIVE ACTION PROGRAM 00820-1 through 6

DOCUMENT 00821
ELECTRONIC REPORTING REQUIREMENTS
CIVIL RIGHTS PROGRAM AND CERTIFIED PAYROLL 00821-1 through 2

DOCUMENT 00859
CONTRACTOR/SUBCONTRACTOR CERTIFICATION FORM 00859-1 through 2

DOCUMENT 00860
COMMONWEALTH OF MASSACHUSETTS PUBLIC EMPLOYMENT LAWS 00860-1 through 2

DOCUMENT 00861
STATE PREVAILING WAGE RATES 00861-1 through 82

DOCUMENT 00870
STANDARD FEDERAL EQUAL EMPLOYMENT OPPORTUNITY
CONSTRUCTION CONTRACT SPECIFICATIONS 00870-1 through 8

DOCUMENT 00875
TRAINEE SPECIAL PROVISIONS 00875-1 through 2

DOCUMENT 00880
MINIMUM WAGES FOR FEDERAL AND FEDERALLY
ASSISTED CONTRACTS..... 00880-1 through 44

DOCUMENT A00801
SPECIAL PROVISIONS A00801-1 through 120

DOCUMENT A00802
DETAIL SHEETS A00802-1 through 16

DOCUMENT A00803
DRAWINGS AND SKETCHES A00803-1 through 84

DOCUMENT A00815
WORK ZONE SAFETY
TEMPORARY TRAFFIC CONTROL A00815-1 through 86

DOCUMENT A00816
RUMBLE STRIP DETAILS A00816-1 through 2

DOCUMENT A00820
REQUEST FOR RELEASE OF MASSDOT AUTOCAD FILES FORM..... A00820-1 through 2

DOCUMENT A00850
MASSACHUSETTS WETLANDS PROTECTION ACT
REQUEST FOR DETERMINATION A00850-1 through 46

TABLE OF CONTENTS (Continued)

DOCUMENT A00851
MASSACHUSETTS WETLANDS PROTECTION ACT
DETERMINATION OF APPALICABILITY A00851-1 through 18

DOCUMENT A00870
UNITED STATES DEPARTMENT OF THE INTERIOR
FISH AND WILDLIFE SERVICE
CONSISTENCY LETTER..... A00870-1 through 10

DOCUMENT A00875
POLICY DIRECTIVE P-22-001 AND POLICY DIRECTIVE P-22-002 A00875-1 through 8

DOCUMENT B00420
PROPOSAL.....B00420-1 through 16

DOCUMENT B00853
SCHEDULE OF PARTICIPATION BY DISADVANTAGED
BUSINESS ENTERPRISES (DBEs)B00853-1 through 2

DOCUMENT B00854
DISADVANTAGED BUSINESS ENTERPRISES (DBE) PARTICIPATION
LETTER OF INTENT.....B00854-1 through 2

DOCUMENT B00855
DBE JOINT CHECK ARRANGEMENT APPROVAL FORM.....B00855-1 through 2

DOCUMENT B00856
JOINT VENTURE AFFIDAVITB00856-1 through 4

*** END OF DOCUMENT ***

THIS PAGE INTENTIONALLY LEFT BLANK

DOCUMENT 00104

**NOTICE TO CONTRACTORS**

Electronic proposals for the following project will be received through the internet using www.bidx.com until the date and time stated below and will be posted on www.bidx.com forthwith after the bid submission deadline. No paper copies of bids will be accepted. All Bidders must have a valid vendor code issued by MassDOT in order to bid on projects. Bidders need to apply for a Digital ID at least 14 days prior to a scheduled bid opening date with www.bidx.com.

TUESDAY, JANUARY 28, 2025 at 2:00 P.M.**

WEST SPRINGFIELD - CHICOPEE

Federal Aid Project No. NHP(IM)/HIP(BR)-0912(310)X

Pavement and Bridge Preservation on I-91

****Date Subject to Change**

PROJECT VALUE = \$7,903,000.00

Bidders must be pre-qualified by the Department in the PAVEMENT - SURFACING OR HIGHWAY - CONSTRUCTION OR BRIDGE - CONSTRUCTION category to bid on the above project. An award will not be made to a Contractor who is not pre-qualified by the Department prior to the opening of Proposals.

All prospective Bidders who intend to bid on this project must obtain "Request Proposal Form (R109)". The blank "Request Proposal Form (R109)" can be obtained at: <https://www.mass.gov/prequalification-of-horizontal-construction-firms>.

All prospective Bidders must complete and e-mail an electronic copy of "Request Proposal Form (R109)" to the MassDOT Director of Prequalification for approval: prequal.r109@dot.state.ma.us.

Proposal documents for official bidders are posted on www.bidx.com. Other interested parties may receive informational Contract Documents containing the Plans and Special Provisions, free of charge.

Bids will be considered, and the contract awarded in accordance with statutes governing such contracts in accordance with Massachusetts General Laws Chapter 30 § 39M.

The Project Bids File Attachments folder for proposals at www.bidx.com shall be used for submitting at the time of bid required information such as the Bid Bond required document, and other documents that may be requested in the proposal.

NOTICE TO CONTRACTORS (Continued)

All parties who wish to have access to information plans and specification must send a “Request for Informational Documents” to MassDOTBidDocuments@dot.state.ma.us.

A Proposal Guaranty in the amount of 5% of the value of the bid is required.

This project is subject to the schedule of prevailing wage rates as determined by the Commissioner of the Massachusetts Department of Labor and Workforce Development, and the Division of Occupational Safety, and the United States Department of Labor.

The Massachusetts Department of Transportation, in accordance with Title VI of the Civil Rights Act of 1964 (78 Stat. 252, 42 U.S.C. §§ 2000d to 2000d-4) and the Regulations, hereby affirmatively ensures that for any contract entered into pursuant to this advertisement, all bidders, including disadvantaged business enterprises, will be afforded full and fair opportunity to submit bids in response to this invitation and will not be discriminated against on the grounds of race, color, national origin in consideration for an Award.

This Proposal contains the "STANDARD FEDERAL EQUAL EMPLOYMENT OPPORTUNITY CONTRACT SPECIFICATIONS (EXECUTIVE ORDER 11246)". The goals and timetables applicable to this proposal for minority and female participation, expressed in percentage terms for the Contractor's aggregate work force in each trade on all work, are contained in Appendices A and B-80 of the above specifications.

The Contractor (hereinafter includes consultants) will comply with the Acts and Regulations relative to Non-discrimination in Federally-assisted programs of the U.S. Department of Transportation, Federal Highway Administration (FHWA), as they may be amended from time to time, which are herein incorporated by reference and made a part of this Contract as contained in Appendices C and D of the above specifications.

NOTICE TO CONTRACTORS (Continued)

PRICE ADJUSTMENTS

This Contract contains price adjustments for hot mix asphalt and Portland cement mixtures, diesel fuel, and gasoline. For reference the base prices are as follows: liquid asphalt \$560.00 per ton, Portland cement \$425.53 per ton, diesel fuel \$2.697 per gallon, and gasoline \$2.388 per gallon, and Steel Base Price Index 378.2. MassDOT posts the **Price Adjustments** on their Highway Division's website at

<https://www.mass.gov/massdot-contract-price-adjustments>

This Contract contains Price Adjustments for steel. See Document 00813 - PRICE ADJUSTMENT FOR STRUCTURAL STEEL AND REINFORCING STEEL for their application and base prices.

MassDOT projects are subject to the rules and regulations of the Architectural Access Board (521 CMR 1.00 et seq.)

Prospective bidders and interested parties can access this information and more via the internet at WWW.COMMBUYS.COM.

BY: Monica G. Tibbits-Nutt, Secretary and CEO, MassDOT
Jonathan L. Gulliver, Administrator, MassDOT Highway Division
SATURDAY, DECEMBER 28, 2024

THIS PAGE IS LEFT BLANK INTENTIONALLY

DOCUMENT 00210

REQUIREMENTS OF MASSACHUSETTS GENERAL LAWS
CHAPTER 30, SECTION 39R;
CHAPTER 30, SECTION 39O

July 1, 1981, updated October 2016

M.G.L. c. 30, § 39R. Award of Contracts; Accounting Statements; Annual Financial Statements; Definitions.

(a) The words defined herein shall have the meaning stated below whenever they appear in this section:

- (1) "Contractor" means any person, corporation, partnership, joint venture, sole proprietorship, or other entity awarded a contract pursuant to sections thirty-eight A1/2 to thirty-eight O, inclusive, of chapter seven and any contract awarded or executed pursuant to section eleven C of chapter twenty-five A, section thirty-nine M of chapter thirty, or sections forty-four A to forty-four H, inclusive, of chapter one hundred and forty-nine, which is for an amount or estimated amount greater than one hundred thousand dollars.
- (2) "Contract" means any contract awarded or executed pursuant to sections thirty-eight A1/2 to thirty-eight O, inclusive, of chapter seven and any contract awarded or executed pursuant to section eleven C of chapter twenty-five A, section thirty-nine M of chapter thirty, or sections forty-four A through forty-four H, inclusive, of chapter one hundred and forty-nine, which is for amount or estimated amount greater than one hundred thousand dollars.
- (3) "Records" means books of original entry, accounts, checks, bank statements and all other banking documents, correspondence, memoranda, invoices, computer printouts, tapes, discs, papers and other documents or transcribed information of any type, whether expressed in ordinary or machine language.
- (4) "Independent Certified Public Accountant" means a person duly registered in good standing and entitled to practice as a certified public accountant under the laws of the place of his residence or principal office and who is in fact independent. In determining whether an accountant is independent with respect to a particular person, appropriate consideration should be given to all relationships between the accountant and that person or any affiliate thereof. Determination of an accountant's independence shall not be confined to the relationships existing in connection with the filing of reports with the awarding authority.
- (5) "Audit", when used in regard to financial statements, means an examination of records by an independent certified public accountant in accordance with generally accepted accounting principles and auditing standards for the purpose of expressing a certified opinion thereon, or, in the alternative, a qualified opinion or a declination to express an opinion for stated reasons.
- (6) "Accountant's Report", when used in regard to financial statements, means a document in which an independent certified public accountant indicates the scope of the audit which he has made and sets forth his opinion regarding the financial statements taken as a whole with a listing of noted exceptions and qualifications, or an assertion to the effect that an overall opinion cannot be expressed. When an overall opinion cannot be expressed the reason therefor shall be stated. An accountant's report shall include as a part thereof a signed statement by the responsible corporate officer attesting that management has fully disclosed all material facts to the independent certified public accountant, and that the audited financial statement is a true and complete statement of the financial condition of the contractor.
- (7) "Management", when used herein, means the chief executive officers, partners, principals or other person or persons primarily responsible for the financial and operational policies and practices of the contractor.
- (8) Accounting terms, unless otherwise defined herein, shall have a meaning in accordance with generally accepted accounting principles and auditing standards.

(b) Subsection (a)(2) hereof notwithstanding, every agreement or contract awarded or executed pursuant to sections thirty-eight A 1/2 to thirty-eight O, inclusive, of chapter seven, or eleven C of chapter twenty-five A, and pursuant to section thirty-nine M of chapter thirty or to section forty-four A through H, inclusive, of chapter one hundred and forty-nine, shall provide that:

- (1) The contractor shall make, and keep for at least six years after final payment, books, records, and accounts which in reasonable detail accurately and fairly reflect the transactions and dispositions of the contractor, and
- (2) Until the expiration of six years after final payment, the office of inspector general, and the commissioner of capital asset management and maintenance shall have the right to examine any books, documents, papers or records of the contractor or of his subcontractors that directly pertain to, and involve transactions relating to, the contractor or his subcontractors, and
- (3) If the agreement is a contract as defined herein, the contractor shall describe any change in the method of maintaining records or recording transactions which materially affect any statements filed with the awarding authority, including in his description the date of the change and reasons therefor, and shall accompany said description with a letter from the contractor's independent certified public accountant approving or otherwise commenting on the changes, and
- (4) If the agreement is a contract as defined herein, the contractor has filed a statement of management on internal accounting controls as set forth in paragraph (c) below prior to the execution of the contract, and
- (5) If the agreement is a contract as defined herein, the contractor has filed prior to the execution of the contracts and will continue to file annually, an audited financial statement for the most recent completed fiscal year as set forth in paragraph (d) below.

(c) Every contractor awarded a contract shall file with the awarding authority a statement of management as to whether the system of internal accounting controls of the contractor and its subsidiaries reasonably assures that:

- (1) transactions are executed in accordance with management's general and specific authorization;
- (2) transactions are recorded as necessary
 - i. to permit preparation of financial statements in conformity with generally accepted accounting principles, and
 - ii. to maintain accountability for assets;
- (3) access to assets is permitted only in accordance with management's general or specific authorization; and
- (4) the recorded accountability for assets is compared with the existing assets at reasonable intervals and appropriate action was taken with respect to any difference.

Every contractor awarded a contract shall also file with the awarding authority a statement prepared and signed by an independent certified public accountant, stating that he has examined the statement of management on internal accounting controls, and expressing an opinion as to:

- (1) whether the representations of management in response to this paragraph and paragraph (b) above are consistent with the result of management's evaluation of the system of internal accounting controls; and
- (2) whether such representations of management are, in addition, reasonable with respect to transactions and assets in amounts which would be material when measured in relation to the applicant's financial statements.

THIS PAGE INTENTIONALLY LEFT BLANK

DOCUMENT 00331

LOCUS MAP

WEST SPRINGFIELD - CHICOPEE Federal Aid Project No. NHP(IM)/HIP(BR)-0912(310)X Pavement and Bridge Preservation on I-91

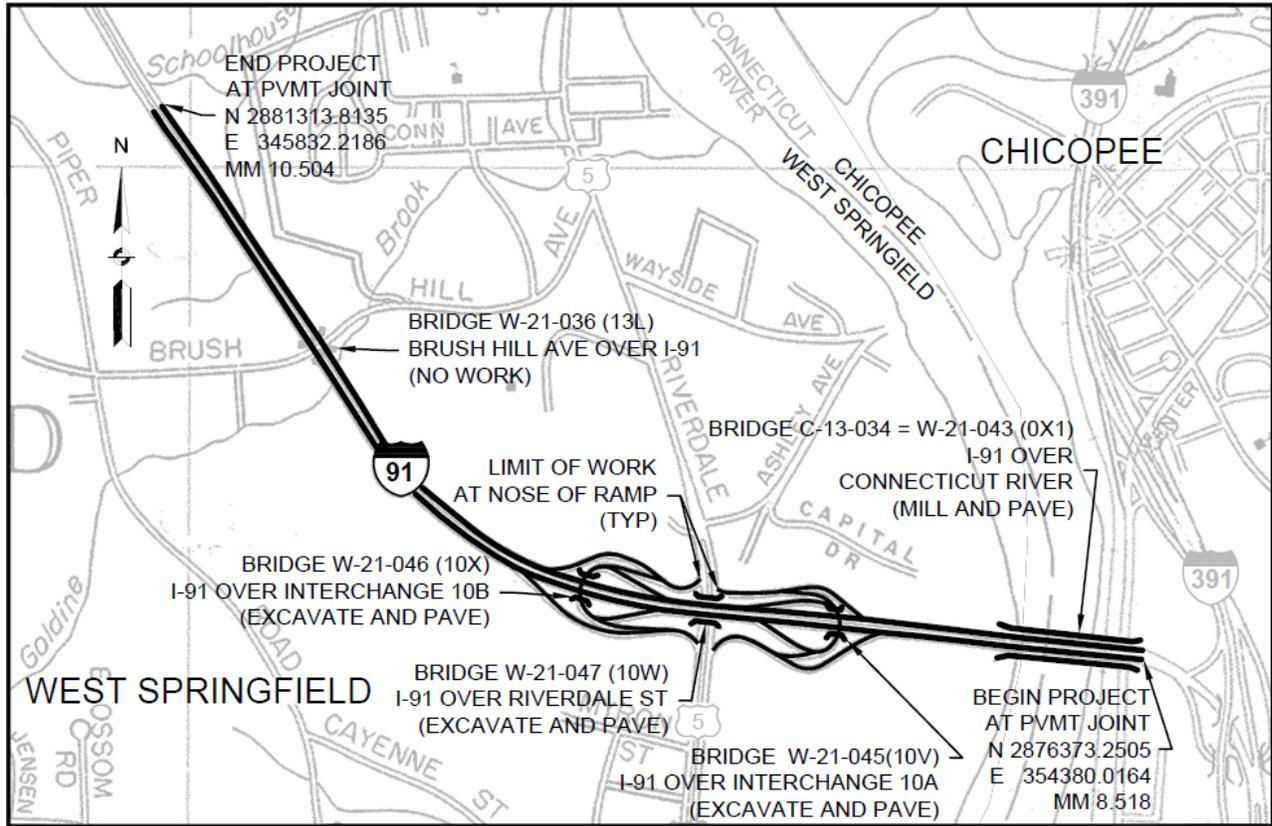

NOT TO SCALE

THIS PAGE IS INTENTIONALLY LEFT BLANK

DOCUMENT 00439



Final Report

Interim Report

CONTRACTOR PROJECT EVALUATION FORM

For instructions on using this form, see Engineering Directive E-10-002, Dated 4/20/2010

Date: _____

City/Town: _____ Contractor: _____

Project: _____ Address: _____

F.A. No. _____ Contract Number: _____

Bid Price: _____ Notice to Proceed: _____

Funds: State: _____ Fed Aid: _____ Current Contract Completion Date: _____

Date Work Started: _____ Date Work Completed*: _____

Contractor's Superintendent: _____

Division: (indicates class of work) Highway: _____ Bridge: _____ Maintenance: _____

*If work was NOT completed within specified time (including extensions) give reasons on following page.

	Excellent 10	Very Good 9	Average 8	7	Fair 6	5	Poor 4	% Rating
1. Workmanship								x 2=
2. Safety								x 2=
3. Schedule								x 1.5=
4. Home Office Support								x 1=
5. Subcontractors Performance								x 1=
6. Field Supervision/ Superintendent								x 1=
7. Contract Compliance								x 0.5=
8. Equipment								x 0.5=
9. Payment of Accounts								x 0.5=
(use back for additional comments)								Overall Rating:

(Give explanation of items 1 through 9 on the following page in numerical order if overall rating is below 80%. Use additional sheets if necessary.)

District Construction Engineer's Signature/Date

Resident Engineer's Signature/Date

Contractor's Signature Acknowledging Report/Date

Contractor Requests Meeting with the District: No Yes Date Meeting Held: _____

Contractor's Comments/Meeting Notes (extra sheets may be added to this form and noted here if needed): _____



Final Report

Interim Report

SUBCONTRACTOR PROJECT EVALUATION FORM

For instructions on using this form, see Engineering Directive E-10-002, Dated 4/20/2010

Date: _____

City/Town: _____

Subcontractor: _____

Project: _____

Address: _____

F.A. No.: _____

Contract Number: _____

Prime Contractor _____

Current Contract Completion Date: _____

Date Work Started: _____

Date Work Completed*: _____

Subcontractor's Superintendent: _____

Type of Work Performed by Subcontractor: _____

*If work was NOT completed within specified time (including extensions) give reasons on following page.

	Excellent 10	Very Good 9	Average 8	7	Fair 6	5	Poor 4	% Rating
1. Workmanship								x 2=
2. Safety								x 2=
3. Schedule								x 1.5=
4. Home Office Support								x 1.5=
5. Field Supervision/ Superintendent								x 1=
6. Contract Compliance								x 1=
7. Equipment								x 0.5=
8. Payment of Accounts								x 0.5=
(use back for additional comments)							Overall Rating:	

(Give explanation of items 1 through 8 on the following page in numerical order if overall rating is below 80%. Use additional sheets if necessary.)

District Construction Engineer's Signature/Date

Resident Engineer's Signature/Date

Contractor Signature Acknowledging Report/Date

Subcontractor Signature Acknowledging Report/Date

Subcontractor Requests Meeting with the District: No Yes Date Meeting Held: _____

Subcontractor's Comments / Meeting Notes (extra sheets may be added to this form and noted here if needed): _____

Contractor's Comments: _____

DOCUMENT 00710
GENERAL CONTRACT PROVISIONS
Revised: 05/06/24

NOTICE OF AVAILABILITY

The STANDARD SPECIFICATIONS FOR HIGHWAYS AND BRIDGES dated 2024, the SUPPLEMENTAL SPECIFICATIONS, the 1996 METRIC CONSTRUCTION AND TRAFFIC STANDARD DETAILS, the 1990 STANDARD DRAWINGS FOR SIGNS AND SUPPORTS; the 1968 STANDARD DRAWINGS FOR TRAFFIC SIGNALS AND HIGHWAY LIGHTING and the 2017 CONSTRUCTION STANDARD DETAILS are available online at <https://www.mass.gov/massdot-highway-division-manuals-and-publications>

SPECIAL PROVISIONS FOR RIGHT-TO-KNOW ACT REQUIREMENTS

The Contractor's attention is directed to Massachusetts General Laws, Chapter 111F, commonly known as the Right-To-Know Act, and to the regulations promulgated pursuant thereto. Among the provisions of the Right-To-Know Act is a requirement that employers make available to employees Materials Safety Data Sheets (MSDS) for any substance on the Massachusetts Substance List (MSL) to which employees are, have been, or may be exposed.

To ensure prompt compliance with these regulations and legislation, the Contractor shall:

1. Deliver to the Department, prior to the start of any work under this contract, copies of MSDS for all MSL substances to be used, stored, processed or manufactured at the worksite by the Contractor.
2. Train employees of the Department, who may be exposed to MSL substances as a result of the Contractor's work under this contract, with regard to those specific substances in accordance with requirements of the Right-To-Know Act.
3. Observe all safety precautions recommended on the MSDS for any MSL substance to be used, stored, processed, or manufactured at the worksite by the Contractor.
4. Inform the Department in writing regarding specific protective equipment recommended in the MSDS for MSL substances to which employees of the Department may be exposed as a result of the Contractor's work under this contract.

The Department shall not be liable for any delay or suspension of work caused by the refusal of its employees to perform any work due to the Contractor's failure to comply with the Right-To-Know Act. The Contractor agrees to hold the Department or the Commissioner of the Department harmless and fully indemnified for any and all claims, demands, fines, actions, complaints, and causes of action resulting from or arising out of the Contractor's failure to comply with the requirements of the Right-To-Know Act.

ALTERNATIVE DISPUTE RESOLUTION

Forum, Choice of Law and Mediations:

Any actions arising out of a contract shall be governed by the laws of Massachusetts and shall be brought and maintained in a State or federal court in Massachusetts which shall have exclusive jurisdiction thereof. MassDOT and the Contractor may both agree to mediation of any claim and will share the costs of such mediation pro rata based on the number of parties involved.

*** END OF DOCUMENT ***

THIS PAGE IS INTENTIONALLY LEFT BLANK

Massachusetts Department of Transportation
Superpave High Performance Surface Course

DOCUMENT 00712

SUPERPAVE HIGH PERFORMANCE SURFACE COURSE

Massachusetts Department of Transportation
 Superpave High Performance Surface Course

SUBSECTION 458
SUPERPAVE HIGH PERFORMANCE SURFACE COURSE
DESCRIPTION
458.20 General.

The work under this Section consists of producing and placing a Hot Mix Asphalt SUPERPAVE High Performance Surface Course (HP) mixture. The mixture will be a high-performance Hot Mix Asphalt (HMA) surface course placed at a lift thickness as shown on plans when compacted. The Contractor shall select whether to utilize a polymer modified asphalt binder or a ground tire rubber modified binder. The volumetric requirements for the mixture will be dependent upon the type of asphalt binder selected. In either case, the mixture will be subject to performance testing as part of the Department's Acceptance.

All work associated with the placement of this item is subject to the requirements of Section 450 Hot Mix Asphalt Pavement, Section M3 Asphaltic Materials, and the additional requirements herein.

MATERIALS
458.30 General.

Provide materials as specified in Section 450 Hot Mix Asphalt Pavement and Section M3 Asphalt Materials, as amended herein:

Performance Graded Asphalt Binder	M3.01.0
Warm Mix Asphalt Additive	M3.01.4
Asphalt Release Agents	M3.01.6
Asphalt Emulsion for Tack Coat	M3.03.0
HMA Joint Sealant	M3.05.0
Hot Mix Asphalt	M3.11.0
Hot Mix Asphalt Production Facility	M3.12.0
Contractor Quality Control Laboratory	M3.13.1
Department Acceptance Laboratory	M3.13.2

HP Mix Design.

HP shall be a mixture comprised of coarse aggregate, fine aggregate, asphalt binder, and warm mix asphalt additive, and may include mineral filler and crumb rubber. Reclaimed Asphalt Pavement (RAP) shall be limited to 10% by mass of the aggregate. Recycled Asphalt Shingles (RAS), Manufactured Asphalt Shingles (MAS), or Recycled Glass Aggregate shall not be used in HP mixtures.

The Contractor shall be responsible for development of an HP Laboratory Trial Mix Formula (LTMF) for each HP mixture type specified for the contract in accordance with the requirements of Subsection 458.30.

(1) Performance Graded Asphalt Binder.

The asphalt binder shall meet the requirements of M3.01.2 Modified Asphalt Binder as well as the following. The asphalt binder shall be modified and achieve the performance grade necessary for the HP mixture to meet the performance testing requirements specified below. The Contractor shall coordinate with the asphalt binder Supplier to select the proper binder grade.

Massachusetts Department of Transportation
Superpave High Performance Surface Course

SBS Modified Asphalt Binder.

The asphalt binder shall meet the requirements of Section M3.01.2A and Table 458.30-1.

The asphalt binder shall be storage-stable, pre-blended, homogeneous, and polymer modified using Styrene-Butadiene (SB), Styrene-Butadiene-Styrene (SBS), or Styrene-Butadiene-Rubber (SBR) formulations. Other methods of binder modification must be reviewed by the MassDOT Research & Materials Section prior to the mix design. The asphalt binder certifications shall provide the continuous PG binder grade, the polymer content, and the polyphosphoric acid content. The binder viscosity shall not exceed 5.0 Pa-s and must maintain satisfactory workability through the mix plant and during placement.

The asphalt binder certifications for the Lots used for the mix design and for production shall provide the continuous PG binder grade, the polymer content and the polyphosphoric acid content. The continuous grading of the asphalt binder used for the mix design shall be reported in the mix design submission.

The asphalt binder Supplier shall provide the Department with necessary materials to fabricate the control samples in order to perform AASHTO T 302.

Table 458.30-1 – Performance Graded Binder for HP

Performance Characteristic	Test Method	Requirement
Minimum Binder Grade	AASHTO M 332	PG 76E-28HP
Minimum Polymer Content, %	AASHTO T 302	7.0%
Jnr at 3.2 kPa, kPa ⁻¹	AASHTO T 350	≤ 0.1
% Recovery at 3.2 kPa, %	AASHTO T 350	≥ 90

Ground Tire Rubber Modified Binder

The asphalt binder shall meet the requirements of M3.01.2 B. Crumb Rubber Modified Asphalt Binder.

(2) Aggregate.

Aggregate shall conform to the requirements of Subsection M3.06.2. Fine aggregate shall be a manufactured sand and have an uncompacted void content of at least 45 percent when tested according to AASHTO T 304, Method A. The minimum sand equivalent of the fine aggregate shall be 45 percent when tested according to AASHTO T 176.

(3) LTMF Design and Verification.

The Contractor shall develop and submit a Laboratory Trial Mix Formula (LTMF), which is to be proposed as a Job Mix Formula, a minimum of sixty (60) days prior to the start of HP production in accordance with the requirements of Subsection 458.30 and MassDOT’s Asphalt Mix Design approval process.

The mixture shall meet the requirements of Section M3.06.4 Hot Mix Asphalt Mixture Design and the following.

Massachusetts Department of Transportation
 Superpave High Performance Surface Course

The control points for the aggregate gradation and volumetric requirements for the mixture shall be dependent upon the modified binder selected for the mixture.

- Mixtures utilizing Polymer Modified Binders will be subject to the volumetric requirements of Superpave mixtures (Table M3.06.4-1 through Table M3.06.4-5) as modified below.
- Mixtures utilizing Asphalt Rubber Modified Binders will be subject to the ARGG volumetric design requirements (Table M3.06.4-8 through Table M3.06.4-9) as modified below.

The Contractor shall not proceed to HP production for the Control Strip as outlined below until the LTMF is verified by the Department.

The Contractor shall submit the LTMF with supporting documentation to the Department along with samples of aggregate material and PG asphalt binder. An adequate amount of the aggregate and PG asphalt binder shall be supplied in order to verify the LTMF. The Department will use these samples for verification of the LTMF and to benchmark the binder and mix design performance. Benchmarking shall include determining the continuous grade of the binder.

Should a change in sources, including the PG asphalt binder, be made or a change in the properties of materials occurs, the Department will require that a new LTMF be developed and approved before production can continue.

Table 458.30-2 – HP Mixture Requirements

Requirements	Polymer Modified		Asphalt Rubber Modified ⁽²⁾
	9.5 mm ⁽²⁾	12.5 mm ⁽²⁾	
Gradation Control Points	Per Tables M3.06.4-1 and Table M3.06.4-2		Per Table M3.06.4-8
Mixture Design Requirements	Per Tables M3.06.4-3 thru M3.06.4-5 ⁽²⁾		Per Table M3.06.4-9
N _{des} , gyrations	50	75	
P _b , % ⁽⁴⁾	≥ 6.5	≥ 6.0	
V _a , %	Per Table 458.30-2		
VMA, %			
Draindown, % ⁽³⁾	≤ 0.3		
VCA _{mix} , % ⁽¹⁾	< VCA _{DRC}		-
LTMF Verification Limits	Per Table M3.06.5-1		Per Table M3.06.5-3
⁽¹⁾ VCA determination shall be performed in accordance with the procedure outlined by MassDOT Research & Materials. ⁽²⁾ The mix design may go outside of the Mixture Design Control Points with prior approval of the Engineer. The mix design will still be required to meet the volumetric and performance criteria. ⁽³⁾ Draindown shall be tested in accordance with AASHTO T 305 at the production temperature. ⁽⁴⁾ Producer may request a waiver on the minimum binder content based on the specific gravity of the aggregate source. Mix design must still meet minimum mixture performance if a waiver is granted.			

Massachusetts Department of Transportation
 Superpave High Performance Surface Course

Table 458.30-2 – Volumetric Requirements for Design and Control of Polymer Modified HP

	Required Density at N _{des}	Voids Filled with Asphalt	Voids in Mineral Aggregate (%)	Dust to Binder Ratio
	(% of G _{mm})	(VFA)	(VMA)	
Design Requirements ⁽¹⁾	96.5	≥ 75	≥ 18.0 (HP-9.5 mm)	0.3 – 1.0
Control Requirements	94.0 - 98.5		≥ 17.0 (HP-12.5 mm)	
⁽¹⁾ The mix design may go outside of the Mixture Design Control Points with prior approval of the Engineer. The mix design will still be required to meet the volumetric and performance criteria.				

(4) LTMF Performance Testing.

Submit to the Department a sample comprised of gyratory specimens, two hundred pounds of loose HP mixture, and a sufficient amount of raw material for performance testing of the LTMF by the Department. The Department reserves the right to be present at the time of mixture and specimen fabrication.

Six gyratory specimens shall be compacted according to AASHTO T 312 to a height of 60 mm and shall have an air void content of 7.0 ± 0.5 percent. The Department reserves the right to be present at the time of molding the gyratory specimens. The specimens will be tested using a Hamburg Wheel Tracking Device (HWTD) according to AASHTO T 324 at 45°C.

Four (4) gyratory specimens shall be compacted according to AASHTO T 312 to a height of 60 mm and shall have an air void content of 7.0 ± 0.5 percent. The Department reserves the right to be present at the time of molding the gyratory specimens. The specimens will be tested in the IDEAL-CT machine according to ASTM D8225.

The Department will use the supplied loose mix sample to compact four (4) beam specimens to an air void content of 7.0 ± 0.5 percent for Flexural Beam Fatigue testing. The Beam Fatigue specimens will be tested according to AASHTO T 321 at 15°C, 10 Hz loading frequency, and 500 micro-strains.

The Department will approve the LTMF if the performance testing requirements in Table 458.30-3 are met. If the LTMF does not meet the HWTD, Flexural Beam Fatigue, and IDEAL-CT criteria, the LTMF shall be rejected.

Massachusetts Department of Transportation
Superpave High Performance Surface Course

Table 458.30-3 – Performance Testing Requirements for HP

Performance Characteristic	Test Method	Requirement
HWTB Maximum Rut Depth	AASHTO T 324 @ 45°C ⁽¹⁾⁽⁴⁾	< 0.25 inch
HWTB Stripping Inflection Point	AASHTO T 324 @ 45°C ⁽¹⁾⁽⁴⁾	> 15,000 passes
Beam Fatigue Test Failure	AASHTO T 321 @ 25°C ⁽²⁾⁽⁴⁾	> 1,000,000 cycles
IDEAL-CT	ASTM D8225 @ 25°C ⁽⁴⁾	≥ 550 ⁽³⁾
⁽¹⁾ After 20,000 passes. ⁽²⁾ Test performed at a strain level of 500 microstrains. ⁽³⁾ IDEAL-CT shall be an average of 4 specimens with no individual specimen with an CT Index < 495. ⁽⁴⁾ Performance samples shall be short term aged according to AASHTO R 30 for 2 hours at 135°C.		

CONSTRUCTION PROCEDURES

458.40 General.

The Construction Procedures shall be in accordance with Section 450 Hot Mix Asphalt Pavement.

458.41 Control Strip Requirements.

HP Control Strip.

Control strips shall be performed in accordance with Subsection 450.51 and the following:

(1) Control Strip Sampling and Testing.

The Contractor and the Department shall independently sample and test the Control Strip Lot for the Quality Characteristics identified in Table 458.41-1.

(2) Control Strip Performance Testing.

The Department will obtain a sample comprised of five (5) 5-gallon metal buckets of loose HP mixture from the Control Strip Lot for performance testing. Test specimens will be prepared and tested in accordance with Subsection 458.30(3).

(3) Evaluation of Control Strip Inspection Data.

The Contractor and the Department shall each evaluate their respective Control Strip inspection data against the requirements for Materials and Workmanship specified in Subsection 450.43 through Subsection 450.52 as well as Subsection 458.41.

(4) Evaluation of Control Strip Sampling and Testing Data.

The Contractor and the Department shall each evaluate their respective Control Strip test results against the Control Strip Quality Limits in Table 458.41-1.

Massachusetts Department of Transportation
Superpave High Performance Surface Course

(5) Evaluation of Control Strip Performance Testing Data.

The Department will evaluate the Control Strip sample performance testing results against the requirements in Table 458.30-3.

(6) Verification of Control Strip Lot and LTMF.

In order for a Control Strip Lot and corresponding LTMF to be Verified, the criteria in Table 458.41-1 and Subsection 450.51 must be met. In addition, the performance testing results shall meet the requirements in Table 458.30-3.

(7) Acceptance and Payment of Control Strips.

If the Control Strip Lot has been Verified in accordance with the requirements above, the Lot will be accepted and paid for at the unit bid price per ton of HP mixture. If the Control Strip Lot is not Verified, the Contractor will be required to construct another Control Strip.

Massachusetts Department of Transportation
Superpave High Performance Surface Course

Table 458.41-1 HP Control Strip Quality Limits

Quality Characteristic	Target	Specification Limits		Engineering Limits		Acceptance Limit
		LSL	USL	LEL	UEL	
PG Asphalt Binder Grading	Per Binder Grade specified	N/A	N/A	Per AASHTO M320	Per AASHTO M320	N/A
PG Asphalt Binder Content (Polymer)	Per JMF	Target - 0.3 %	Target + 0.3 %	Target - 0.4 %	Target + 0.4 %	≥ 70 PWL
PG Asphalt Binder Content (Asphalt Rubber)	Per JMF	Target - 0.4 %	Target + 0.4 %	Target - 0.6 %	Target + 0.6 %	≥ 70 PWL
Volumetrics: Air Voids (Polymer)	Per JMF	Target - 1.3 %	Target + 1.3 %	Target - 2.0 %	Target + 2.0 %	≥ 70 PWL
Volumetrics: Air Voids (Asphalt Rubber)	Per JMF	Target - 1.3 %	Target + 1.3 %	Target - 2.0 %	Target + 2.0 %	For Information Only
Combined Gradation: Passing #4 and Larger Sieves	Per JMF	N/A	N/A	Target - 6%	Target + 6%	N/A
Combined Gradation: Passing #8 Sieve	Per JMF	N/A	N/A	Target - 5%	Target + 5%	N/A
Combined Gradation: Passing #16 to #50 Sieve	Per JMF	N/A	N/A	Target - 3%	Target + 3%	N/A
Combined Gradation: Passing #100 Sieve	Per JMF	N/A	N/A	Target - 2%	Target + 2%	N/A
Combined Gradation: Passing #200 Sieve	Per JMF	N/A	N/A	Target - 1.5%	Target + 1.5%	N/A
In-Place HP Mat Density (Cores)	95% of G_{mm}	92.5% of G_{mm}	97.5% of G_{mm}	91.5% of G_{mm}	98.5% of G_{mm}	≥ 70 PWL
Thickness ⁽¹⁾ : (All Courses 1 inch or greater)	Per Plans	- 20 % of Target Thickness	+ 20 % of Target Thickness	- 30 % of Target Thickness	+ 30 % of Target Thickness	≥ 70 PWL
Ride Quality ⁽¹⁾ : Posted Speed Limit ≥ 55 mph	50 in/mile	N/A	70 in/mile	N/A	80 in/mile	≥ 70 PWL
Ride Quality ⁽¹⁾ : Posted Speed Limit ≥ 40 mph, but < 55 mph	70 in/mile	N/A	100 in/mile	N/A	110 in/mile	>70 PWL
⁽¹⁾ To be evaluated for applicable pavement courses subject to testing per Subsection 450.65F. The Quality Limits for Ride in Table 450.5 shall only apply to Control Strips for the final pavement course. For pavement courses below the final pavement course that are subject to Ride Quality testing, the Mean IRI for the Control Strip Sublots shall be less than or equal to the Maximum Mean IRI values in Table 450.51-1.						

Massachusetts Department of Transportation
Superpave High Performance Surface Course

CONTRACTOR QUALITY CONTROL

458.60 General.

The Contractor shall provide a Quality Control (QC) system in accordance with the provisions of Section 450 Hot Mix Asphalt, as modified below.

458.61 Contractor Quality Control Plan.

The QC system shall be detailed in a Quality Control Plan (QC Plan). This may be either a standalone QC Plan for the HP mixture, or if a QC Plan is required for other HMA mixtures on the project, the HP mixture may be addressed in that QC Plan. The QC Plan shall conform to the requirements in Subsection 450.61 for submittal, format, contents, and approval.

458.62 Quality Control Personnel Requirements.

The Contractor shall provide the QC personnel required by Subsection 450.62.

458.63 Quality Control Laboratory Facility Requirements.

The Contractor shall provide the QC laboratory facilities required by Subsection 458.30.

458.64 Quality Control Inspection.

The Contractor shall perform Quality Control inspection of the HP mixture in accordance with the requirements of Subsection 450.64, as amended herein.

A. QC Inspection for Preparation of Underlying Surface.

If HMA patching is required on the approach pavement, Quality Control inspection of HMA for Patching shall be performed in accordance with the requirements of Subsection 450.64A and Table 450.64-1. Quality Control inspection of the tack coat for HMA mixtures shall be performed in accordance with the requirements of Table 450.64-2.

B. QC Inspection for Production & Placement of HP Lots.

The Contractor's QC personnel will perform Quality Control inspection at both the HMA production facility and at the site of HP field placement to ensure that the production and placement processes are providing work conforming to the contract requirements. For purposes of QC inspection, the total quantity of HP produced and placed during the same construction season will constitute a Lot. Each in-place Lot shall be divided into 100 lane-feet Sublots. The specific attributes to be inspected for each HP Lot shall be in accordance with the requirements of Subsection 450.43 through Subsection 450.52, as amended herein, and as outlined in Table 450.64-3 and Table 450.64-4.

458.65 Quality Control Sampling and Testing Requirements.

The Contractor shall perform Quality Control sampling and testing of the HP mixture in accordance with the requirements of Subsection 450.65, as amended herein.

Massachusetts Department of Transportation
Superpave High Performance Surface Course

A. Quality Control Testing of Prepared Underlying Surface.

Quality Control sampling and testing of HMA for Patching shall be performed in accordance with the requirements of Table 450.65-1.

B. Quality Control Testing of HP Lots.

The Contractor's QC personnel will perform Quality Control sampling and testing at both the HMA production facility and at the site of HP field placement to ensure that the production and placement processes are providing work conforming to the contract requirements. All QC sampling and testing shall be in accordance with the AASHTO, ASTM, NETTCP, or Department procedures specified in Table 458.65-1 below. The Contractor shall furnish approved containers for all material samples. The Department shall be provided the opportunity to monitor and witness all QC sampling and testing.

Quality Control testing of the HP pavement course for Ride Quality will only be required when the criteria in Subsection 450.65F(11) are met.

Massachusetts Department of Transportation
 Superpave High Performance Surface Course
Table 458.65-1 - Minimum Quality Control Sampling & Testing of HP Lots

Quality Characteristic	Test Method(s)	Sublot Size	Minimum Test Frequency	Point of Sampling	Sampling Method
PG Asphalt Binder Content	AASHTO T 308	600 tons	1 per Sublot ⁽¹⁾	From Haul Vehicle at Plant	Random AASHTO R 97 and R 47
Combined Aggregate Gradation	AASHTO T 30	600 tons	1 per Sublot ⁽¹⁾	From Haul Vehicle at Plant	Random AASHTO R 97 and R 47
Maximum Theo. Specific Gravity	AASHTO T 209 (Method A)	600 tons	1 per Sublot ⁽¹⁾	From Haul Vehicle at Plant	Random AASHTO R 97 and R 47
Bulk Specific Gravity	AASHTO T 166 (Method A)	600 tons	1 per Sublot ⁽¹⁾	From Haul Vehicle at Plant	Random AASHTO R 97 and R 47
PG Asphalt Binder Content	AASHTO T 308	600 tons	1 per Sublot ⁽¹⁾	From Haul Vehicle at Plant	Random AASHTO R 97 and R 47
Combined Aggregate Gradation	AASHTO T 30	600 tons	1 per Sublot ⁽¹⁾	From Haul Vehicle at Plant	Random AASHTO R 97 and R 47
Volumetrics: Air Voids, VMA, VFA	AASHTO T 312 and R 35	600 tons	1 per Sublot ⁽¹⁾	From Haul Vehicle at Plant	Random AASHTO R 97 and R 47
In-place Mat Density (Density Gauge)	AASHTO T 343 or T 355	150 tons	1 per Sublot ⁽¹⁾	From Compacted Mat	Selective & Random AASHTO T 343 or T 355
In-place Mat Density (Cores)	AASHTO T 269	600 tons	1 per Sublot ⁽¹⁾	From Compacted Mat	Random AASHTO R 67
Thickness	ASTM D3549	600 tons	1 per Sublot ⁽¹⁾	From Compacted Mat	Random AASHTO R 67
Transverse Joint Density	AASHTO T 343 or T 355	Each Joint	1 per Sublot ⁽¹⁾	At Finished Joint	Random AASHTO T 343 or T 355
Longitudinal Joint Density	AASHTO T 343 or T 355	500 ft per Joint	1 per Sublot ⁽¹⁾	At Finished Joint	Random AASHTO T 343 or T 355
⁽¹⁾ In the event that the total daily HP production is less than one Sublot, a minimum of one random QC sample shall be obtained for the day's production.					

458.66 Quality Control Documentation and Data Evaluation.

The Contractor shall document all QC inspection, sampling and testing and perform evaluation of QC data in accordance with Subsection 450.66.

458.67 Corrective Action.

As part of the Quality Control system, the Contractor shall implement corrective action in accordance with Subsection 450.67 for any part of a Lot that is determined by inspection or testing to not be in conformance with the quality requirements.

Massachusetts Department of Transportation
Superpave High Performance Surface Course

458.68 Quality Control Records System.

The Contractor shall maintain a QC records system for the HP in accordance with Subsection 450.68.

DEPARTMENT ACCEPTANCE**458.70: General**

The Department is responsible for performing all Acceptance activities and making the final Acceptance determination for each HP Lot produced and placed. The Department's Acceptance System will include monitoring the Contractor's QC activity and performing Acceptance inspection, sampling and testing in order to determine the Quality and corresponding payment for each Lot.

458.71 Acceptance System Approach.

The Department's Acceptance determination for each Lot of HP will be based on an evaluation of its Acceptance inspection information, testing data, and performance testing results.

458.72 Department Monitoring of Contractor Quality Control.

The Department will monitor the Contractor's Quality Control system in accordance with Section 450.72.

458.73 Acceptance Inspection.

The Department will perform Acceptance inspection of all work items addressed under Section 450 Hot Mix Asphalt Pavement and herein in accordance with Subsection 450.73, to ensure that all materials and completed work are in conformance with the contract requirements.

A. Acceptance Inspection of Prepared Underlying Surface.

If HMA patching is required on the approach pavement, Acceptance inspection of HMA for Patching shall be performed in accordance with the requirements of Subsection 450.73 and Table 450.73.-1.

Acceptance inspection of the tack coat for HMA mixtures shall be performed in accordance with the requirements of Table 450.73-2.

B. Acceptance Inspection of HP Lots.

The Department will perform Acceptance inspection of the HP at both the HMA production facility and at the site of HP field placement. For purposes of Acceptance inspection, the total quantity of HP mixture produced and placed during the same construction season will constitute a Lot. Each in-place HP Lot will be divided into 100 lane-feet Sublots. The attributes to be inspected and minimum frequency of inspection will be in accordance with the requirements of Subsection 450.73.

458.74 Acceptance Sampling & Testing.

The Department will perform sampling and testing of the HP mixture in accordance with the requirements of Subsection 450.74, as amended herein.

The Department will obtain random samples for Acceptance testing from all Sublots from the HP production facility and at the site of HP field placement in accordance with Subsection 450.74A. The

Massachusetts Department of Transportation
 Superpave High Performance Surface Course

specific Quality Characteristics subject to Department Acceptance testing are identified in Table 458.74-1. All Acceptance testing of HP Lots will be performed by the Department in accordance with the AASHTO, ASTM, NETTCP, or Department test methods specified in Subsection 450.74F and Table 458.74-1.

Acceptance testing of the HP pavement course for Ride Quality will only be required when the criteria in Subsection 450.65F(11) are met.

Table 458.74-1 - Department Acceptance Sampling & Testing of HP Lots

Quality Characteristic	Test Method(s)	Sublot Size	Minimum Test Frequency	Point of Sampling	Sampling Method
PG Asphalt Binder Grading	Per M3.01.0: Performance Graded Asphalt Binder	12,000 tons of HP using same PG Grade	1 per Sublot	From In-line Sample Valve at HMA Plant	Random AASHTO R 66
PG Asphalt Binder Content	AASHTO T 308	600 tons	1 per Sublot sampled per 450.74 ⁽¹⁾	From Haul Vehicle at HMA Plant	Random AASHTO R 97 and R 47
Combined Aggregate Gradation	AASHTO T 30	600 tons	1 per Sublot sampled per 450.74 ⁽¹⁾	From Haul Vehicle at HMA Plant	Random AASHTO R 97 and R 47
Volumetrics: Air Voids	AASHTO T 312 and R 35	600 tons	1 per Sublot sampled per 450.74 ⁽¹⁾	From Haul Vehicle at HMA Plant	Random AASHTO R 97 and R 47
In-place HP Mat Density (Cores)	AASHTO T 269	600 tons	1 per Sublot sampled per 450.74 ⁽¹⁾	From Compacted HP Course	Random AASHTO R 67
In-place HP Mat Density (Bridge Courses)	AASHTO T 343 or T 355	150 tons	1 per Sublot sampled per 450.74 ⁽¹⁾	From Compacted HP Course	Random AASHTO T 343 or T 355
Thickness	ASTM D3549	600 tons	1 per Sublot sampled per 450.74 ⁽¹⁾	From Compacted HP Course	Random AASHTO R 67
Ride Quality (IRI)	AASHTO R 54 per 450.65	0.1 miles per each Wheel Path	1 per Sublot	Each Pavement Course per 450.65	Random per 450.65

⁽¹⁾ In the event that the total daily HP production is less than one Sublot but greater than 150 tons, a minimum of one random Acceptance sample shall be obtained for the day's production.

Performance Testing for Acceptance.

The Department will obtain random samples for performance testing from the first Sublot and from a minimum of 25% of all Sublots produced and placed thereafter. Each sample will be comprised of five (5) 5-gallon metal buckets of loose HP mixture. Test specimens will be prepared and tested in accordance with AASHTO T 324 and AASHTO T 321. The Department will evaluate the performance testing results against the requirements in Table 458.30-3.

458.75 Split Sample Correlation.

Split Sample Correlation shall be performed when Validated Contractor QC test data is to be included in the acceptance determination in accordance with Subsection 450.75.

Massachusetts Department of Transportation
Superpave High Performance Surface Course

458.76 Lot Acceptance Determination Based on Inspection Results.

The Department’s Acceptance inspection results will be used in the final acceptance determination for each HP pavement Lot in accordance with Subsection 450.76.

458.77 Lot Acceptance Determination Based on Testing Data.

The Department’s Acceptance testing data will be evaluated for the final acceptance determination for each HP Lot in accordance with Subsection 450.77 and Table 458.77-1 below.

Table 458.77-1 - Quality Limits for Acceptance of HP Lots

Quality Characteristic	Target	Specification Limits		Engineering Limits		Acceptance Limit
		LSL	USL	LEL	UEL	
PG Asphalt Binder Grading	Per Binder Grade specified	N/A	N/A	Per M3.01.0		N/A
PG Asphalt Binder Content (Polymer)	Per JMF	Target - 0.3 %	Target + 0.3 %	Target - 0.4 %	Target + 0.4 %	60 PWL
PG Asphalt Binder Content (Rubber)	Per JMF	Target - 0.4%	Target + 0.4%	Target - 0.6%	Target + 0.6%	60 PWL
Volumetrics: Air Voids	Per JMF	Target - 1.3 %	Target + 1.3 %	Target - 2.0 %	Target + 2.0 %	60 PWL
Volumetrics: Air Voids (Asphalt Rubber)	Per JMF	Target - 1.3 %	Target + 1.3 %	Target - 2.0 %	Target + 2.0 %	For Information Only
In-Place HMA Mat Density (Cores)	95% of Gmm	92.5% of Gmm	97.5% of Gmm	91.5% of Gmm	98.5% of Gmm	60 PWL
In-Place HMA Mat Density (Bridge Courses)	95% of Gmm	N/A	N/A	90% of Gmm	N/A	N/A
Thickness: (All Courses 1 in. or greater)	Per Plans	-20% of Target Thickness	+20% of Target Thickness	-30% of Target Thickness	+30% of Target Thickness	60 PWL
Ride Quality: Posted Speed Limit ≥ 55 mph ⁽¹⁾	50 in/mile	N/A	70 in/mile	N/A	80 in/mile	60 PWL
Posted Speed Limit ≥ 40 mph, but < 55 mph ⁽¹⁾	70 in/mile	N/A	100 in/mile	N/A	110 in/mile	60 PWL
Ride Quality: Posted Speed Limit <40 mph	Not subject to Ride Quality Testing					
⁽¹⁾ Projects with posted speed limits that fall into more than one of the Posted Speed Limit ranges above will be divided into multiple Lots and evaluated separately.						

Massachusetts Department of Transportation
Superpave High Performance Surface Course

Lot Acceptance Determination Based on Performance Testing.

The Department's Performance testing data for each HP Lot will be evaluated against the requirements in Table 458.30-3. The Department will accept a Lot if the evaluation of all Acceptance testing data for the Lot is in conformance with the Quality Limits specified in Table 458.30-3 and Table 458.77-1 above.

458.78 Quality Level Analysis Procedures.

For each HP Category A or B Lot, the Engineer will determine the Lot Quality Level, for the applicable Quality Characteristics in Table 458.77-1, using the Quality Level Analysis (QLA) procedures outlined in Subsection 450.78.

For each HP pavement course that is subject to Ride Quality testing per Subsection 450.65F(11), the Department will determine the Quality Level for the Ride Quality of each HP Lot, using the Quality Level Analysis (QLA) procedures outlined in Subsection 450.78.

DISPUTE RESOLUTION**458.80 Procedures for Dispute Resolution.**

The Contractor or the Department may dispute any of the test values that are utilized in the Acceptance determination for a given HP Lot in accordance with the procedures contained in Subsection 450.80 through Subsection 450.84.

COMPENSATION**458.90 Method of Measurement.**

HMA for Patching (if required), Tack Coat, and Hot Applied Joint Adhesive will be measured as specified in Section 450.90.

High Performance pavement course mixtures will be measured by the ton and shall be the actual pavement course quantity complete, in place, and accepted by the Engineer. The quantity shall be determined only by weight slips that have been properly countersigned by the Engineer at the time of delivery.

When it is determined that the mean thickness of the pavement is not in conformance with the specification limit thicknesses, as specified under Subsection 450.74, Part F(6), the quantity shall be determined based on the actual pavement course quantity complete, in place, at the target thickness specified on the plans and accepted by the Engineer. Material quantity above the target thickness shall not be considered for payment.

458.91 Basis of Payment.

HMA for Patching (if required), Tack Coat, and Hot Applied Joint Adhesive will be paid for as specified in Section 450.91.

Each HP pavement course will be paid for at the contract unit price per ton of in-place mixture under the HP Pay Items specified (Pay Items 458.1 and 458.2). Payment shall include sweeping the underlying surface, transportation, delivery, placement (including providing an MTV, when required), and compaction of each HP pavement course in accordance with Subsection 458.40 and 458.41. Mobile lighting for nighttime milling and paving, in accordance with Subsection 450.47, Part C, is considered incidental to the cost of each HP pavement course placed.

Massachusetts Department of Transportation
 Superpave High Performance Surface Course

All sawcutting required for transverse joints or longitudinal joints in accordance with Subsection 450.49 shall also be included in the contract unit price for each HP pavement course. All required sawcutting in the existing pavement in accordance with this specification will be included in the contract unit price for each HP pavement course, except sawcutting pavement for box widening, which will be paid under Item 482.5.

458.92 Pay Adjustment (PA).

Payment adjustments for each HP Lot will be made, for the applicable Quality Characteristic(s) in Table 458.77-1, in accordance with Subsection 450.92.

458.93	Payment Items	Payment Unit
458.1	SUPERPAVE High Performance Surface Course (HP - 9.5)	Ton
458.2	SUPERPAVE High Performance Surface Course (HP - 12.5)	Ton
451.	HMA for Patching	Ton
452.	Asphalt Emulsion for Tack Coat	Gallon
453.	HMA Joint Sealant	Foot
999.490	HMA Pay Adjustment – PG Asphalt Binder Content ⁽¹⁾	Dollar
999.491	HMA Pay Adjustment – Volumetrics (Air Voids) ⁽¹⁾	Dollar
999.492	HMA Pay Adjustment – In-place Mat Density ⁽¹⁾	Dollar
999.493	HMA Pay Adjustment – Thickness ⁽¹⁾	Dollar
999.494	HMA Pay Adjustment – Ride Quality ⁽¹⁾	Dollar

(1) Not a bid item

DOCUMENT 00713

Subsection 701
Cement Concrete Sidewalks, Pedestrian Curb Ramps, and Driveways
and
Guide to the Interim Subsection 701
Cement Concrete Sidewalk Specification

(March 31, 2022)

THIS PAGE INTENTIONALLY LEFT BLANK

SUBSECTION 701: CEMENT CONCRETE SIDEWALKS, PEDESTRIAN CURB RAMPS, AND DRIVEWAYS

Replace this Subsection with the following:

INTERIM SUBSECTION 701: CEMENT CONCRETE SIDEWALKS, PEDESTRIAN CURB RAMPS, AND DRIVEWAYS

DESCRIPTION

701.20: General

This work shall consist of the construction of cement concrete sidewalks, pedestrian curb ramps, and driveways in accordance with the specifications and within the tolerances established on the plans.

MATERIALS

701.30: General

Materials shall meet the requirements specified in the following Subsections of Division III, Materials except as noted herein:

Gravel Borrow, Type b.....	M1.03.0
Cement Concrete ($\geq 4,000$ psi).....	M4.02.00
Preformed Expansion Joint Filler.....	M9.14.0 ^[1]

^[1] Preformed expansion joint filler shall conform to Subsection M9.14.0 or ASTM D8139.

The following best practices may be incorporated into the cement concrete mix design at no additional cost to the Department as identified herein.

A. Combined Aggregate System.

The combined aggregate system for the mix design may be analyzed using the Tarantula Curve, Shilstone Chart, fineness modulus, and coarse aggregate content to enhance the properties of the concrete.

1. Tarantula Curve.

The combined aggregate system for the mix design may be analyzed using the Tarantula Curve to evaluate potential properties of the concrete, including workability, segregation, edge slumping, surface finishing, and cohesion.

Table 701.30-1: Tarantula Curve Particle Size Distribution

Sieve Opening	Percent by Mass Targets (%)		Percent by Mass Retained (%)		
	Passing	Retained			
1-1/2 in.	100	–	–	–	–
1 in.	92	8	0 – 16	–	–
3/4 in.	82	10	0 – 20	–	–
1/2 in.	69	13	4 – 20	–	–
3/8 in.	56	13	4 – 20	–	–
No. 4	43	13	4 – 20	–	–
No. 8	37	6	0 – 12	Coarse Sand 20 – 40	–
No. 16	31	6	0 – 12		–
No. 30	18	13	4 – 20	Fine Sand 24 – 34	–
No. 50	5	13	4 – 20		–
No. 100	0	5	0 – 10		–
No. 200	0	0	0 – 2		–

2. Shilstone Workability-Coarseness Chart.

The combined aggregate system for the mix design may be analyzed using the Shilstone Workability-Coarseness Chart, to evaluate potential properties of the concrete, including workability.

Table 701.30-2: Shilstone Workability-Coarseness

Zone	Property	Cause
Zone I	Gap-graded; High potential for segregation during placement and consolidation; Cracking, blistering, spalling, and scaling	Deficiency in intermediate particles; Non-cohesive
Zone II	Optimum mixture for nominal maximum aggregate size from 2 in. – 3/4 in.	Optimized workability factor and coarseness factor
Zone III	Optimum mixture for nominal maximum aggregate size < 3/4 in.	Optimized workability factor and coarseness factor
Zone IV	Sticky; High potential for segregation during consolidation and finishing; Variable strength, high shrinkage, cracking, curling, spalling, and scaling	Excessive fines
Zone V	Rocky; Lacking plasticity	Excessive amount of coarse and intermediate aggregate

Figure 701.30-1: Shilstone Workability-Coarseness Chart

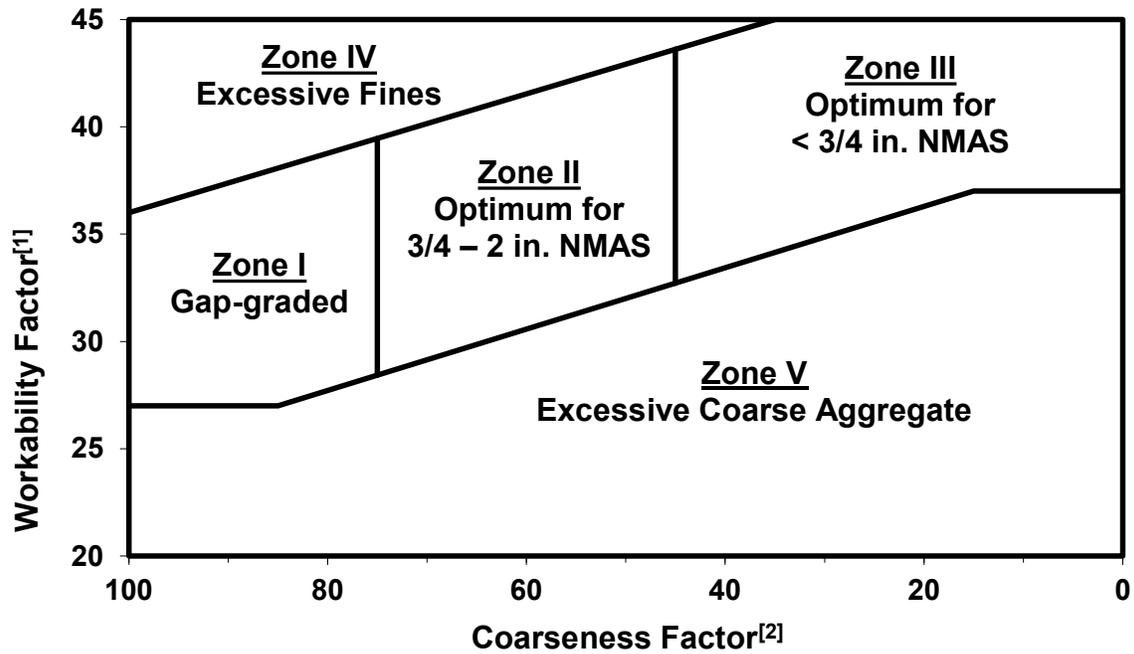

^[1] The workability factor is determined by the equation $WF = W + (C - 564) / 38$, where WF = workability factor, W = percent passing No. 8 sieve and C = total cementitious materials content.

^[2] The coarseness factor is determined by the equation $CF = (Q/R) / 100$, where CF = coarseness factor, Q = cumulative percent retained on 3/8 in. sieve and R = cumulative percent retained on No. 8 sieve.

3. Fineness Modulus.

The combined aggregate system for the mix design may be analyzed using the fineness modulus, to evaluate potential properties of the concrete, including the fineness or coarseness of the mix design and estimating the design proportions of fine and coarse aggregates. The coarseness of the mix design increases as the fineness modulus increases. The fineness modulus is determined by calculating the total cumulative percentages by mass retained on each designated sieve and dividing by 100.

4. Coarse Aggregate Content.

The combined aggregate system for the mix design may be analyzed using the coarse aggregate content. The coarse aggregate content is determined by calculating the total cumulative percentages by mass retained on the No. 4 sieve.

B. Paste System.

The quality of the paste system is determined by the water-cementitious ratio, air content, cementitious materials, and chemical admixtures incorporated into the mix design.

1. Water-Cementitious Ratio.

The water-cementitious ratio for the mix design may be analyzed to evaluate potential properties of the concrete, including strength, concrete and reinforcement bonding, and resistance to freezing, thawing, de-icing, sulfate reaction, corrosion of steel reinforcement, drying shrinkage, cracking, and

volume change from wetting and drying. The water-cementitious ratio is determined by calculating the total water content by mass and dividing by the total cement and supplementary cementitious material (SCM) content by mass. The recommended water-cementitious ratio design target is identified in Table 701.30-3. The water-cementitious ratio shall be less than or equal to 0.45.

Table 701.30-3: Freezing, Thawing, and De-icing Resistance

Exposure Class	Severity	Condition	Water-Cementitious Ratio
			Requirement
F3	Very Severe	Exposed to freezing and thawing cycles and accumulation of snow, ice, and de-icing chemicals; Frequent exposure to water	≤ 0.45

2. Air Content.

The air content for the mix design may be analyzed to evaluate potential properties of the concrete, including strength and resistance to freezing, thawing, de-icing, and sulfate reaction. The recommended air content design targets are identified in Table 701.30-4.

Table 701.30-4: Freezing, Thawing, and De-icing Resistance

Exposure Class	Severity	Condition	Nominal Maximum Aggregate Size (in.)	Air Content Target Recommendation (%)
F3	Very Severe	Exposed to freezing and thawing cycles and accumulation of snow, ice, and de-icing chemicals; Frequent exposure to water	3/8	7.5
			1/2	7.0
			3/4	7.0
			1	6.5
			1 1/2	6.5

3. Cement and Supplementary Cementitious Materials Content.

The cement and supplementary cementitious materials content incorporated into the mix design shall promote quality properties of the cement concrete, including resistance to alkali silica reaction, freezing, thawing, de-icing, and sulfate reaction. Incorporation of supplementary cementitious materials (SCM) in cement concrete may affect workmanship properties, including workability, bleed rate, setting time, and other properties. Adequate adjustments in Contractor workmanship practices, including placement, finishing, curing, and other construction practices shall be required to account for these changes in properties and to prevent scaling due to freezing, thawing, and de-icing cycles. The cement and supplementary cementitious materials content shall meet the design criteria identified in Table 701.30-5.

Table 701.30-5: Alkali Silica Reaction and Freezing, Thawing, and De-icing Resistance^{[1][2]}

Exposure Class	Severity	Condition	Material	Replacement by Weight of Cement (%)
F3	Very Severe	Exposed to freezing and thawing cycles and accumulation of snow, ice, and de-icing chemicals; Frequent exposure to water	Low Alkali Cement ($\leq 0.60\%$ Alkalinity)	–
			Blended Hydraulic Cement ^[3]	–
			Fly Ash (Class F)	15 – 30
			Slag (Grade 100 or 120)	25 – 50
			Silica Fume	5 – 10
			Total SCM	≤ 50
			Total Fly Ash and Silica Fume	≤ 35

^[1] Acceptable replacement by weight of cement for alkali silica reaction resistance shall be determined by the alkali silica reaction resistance performance test results and the criteria identified in Table 701.73-1: Minimum Acceptance Sampling and Testing Requirements.

^[2] Test results meeting the alkali silica reaction resistance performance criteria of Table 701.30-6: Alternative Performance Evaluation to Alkali Silica Reaction Resistance Design Criteria may supersede the replacement by weight of cement design criteria.

^[3] SCMs in blended hydraulic cement shall meet the criteria identified for fly ash, slag, and silica fume.

Table 701.30-6: Alternative Performance Evaluation to Alkali Silica Reaction Resistance Design Criteria

Method	Quality Characteristic	Criteria
C295	Petrographic Examination for Potential Alkali Aggregate Reactive Constituents and Deleterious Materials in Aggregate ^[1]	–
	Optically Strained, Microfractured or Microcrystalline Quartz (%)	≤ 5.0
	Chert or Chalcedony (%)	≤ 3.0
	Trydimite or Cristobalite (%)	≤ 1.0
	Opal (%)	≤ 0.5
	Natural Volcanic Glass (%)	≤ 3.0
T 380	Alkali Silica Reaction Resistance: Expansion of Miniature Concrete Prisms at 56 days (%)	≤ 0.03 ^[2]

^[1] Examination of aggregate shall be performed and reported to identify and quantify potential alkali-aggregate reactive constituents and deleterious materials in aggregate, as defined in ASTM C294 Standard Descriptive Nomenclature for Constituents of Concrete Aggregates and ASTM C295 Standard Guide for Petrographic Examination of Aggregates for Concrete.

^[2] 56-day expansion results greater than 0.03 but less than or equal to 0.04 shall be considered non-reactive if the average two-week rate of expansion from day 56 to day 84 is less than or equal to 0.01%, otherwise, expansion results shall be considered reactive.

4. Chemical Admixtures.

Chemical admixtures may be incorporated into the mix design to enhance the properties of the concrete.

Table 701.30-7: Chemical Admixtures

Spec.	Type	Chemical Admixture	Properties
M 194	A	Water-Reducing	Increases Workability and Air Content; Decreases Water Demand (5 – 10%, 3 – 6 in. Slump)
	B	Retarding	Increases Initial and Final Setting Time, Air Content, Long-Term Strength; Offsetting of Accelerating Effect of Hot Weather; Decreases Early-Age Strength
	C	Accelerating	Increases Early-Age Strength; Decreases Initial and Final Setting Time
	D	Water-Reducing and Retarding	Type A and Type B Admixture Properties
	E	Water-Reducing and Accelerating	Type A and Type C Admixture Properties
	F	High Range Water-Reducing	Increases Workability (More Effective than Type A), Air Content, Early-Age Strength, and Ultimate Strength; Decreases Water Demand (12 – 40%, > 6 in. Slump) and Permeability
	G	High Range Water-Reducing and Retarding	Type F and Type B Admixture Properties
	S-SRA	Shrinkage Reducing	Increases Setting Time; Decreases Drying Shrinkage Cracking and Bleed Rate
	S-CRA	Crack Reducing	Decreases Cracking (More Effective than SRAs) and Crack Width
M 154	AEA	Air-Entraining	Increases Cohesion, Workability, Stabilization of Air Bubbles, Resistance to Freezing, Thawing, and De-icing, Resistance to Alkali-Reactive Environment, and Resistance to Sulfate Reaction
M 194 ^[1]	MRWRA	Mid Range Water-Reducing	Type A and Type F Admixture Properties; Increases Workability (Especially Concrete with SCMs); Decreases Water Demand (6 – 12 %, 5 – 8 in. Slump)
C1622	CWA	Cold Weather	Increases Hydration Rate; Decreases Freezing Point of Mixing Water

^[1] Mid range water-reducing admixtures (MRWRA) may meet either water-reducing (A) or high range water-reducing (F) admixture criteria.

5. Paste Content.

The paste content for the mix design may be optimized to enhance potential properties of the concrete, including workability, strength, permeability, and resistance to drying shrinkage and cracking and volume change from wetting and drying. The volume of paste should adequately fill the voids and provide sufficient separation between the aggregate particles to promote workability and effective bonding of particles.

Table 701.30-8: Paste Content

Mix Design Characteristic	Recommendation
Volume of Cement Concrete (cf) ^[1]	27
Paste Content (%) ^[2]	≤ 28 ^[3]
Paste Content to Aggregate Void Content Ratio ^[4]	1.25 – 1.75
Excess Volume of Paste for Workability (%) ^[5]	–

^[1] The volume of cement concrete is determined by the following equation, where W = Weight (lbs.), SG = Specific Gravity, D = Density (pcf), and V = Volume (cf).

$$\begin{aligned}
 V_{\text{CEMENT}} &= W_{\text{CEMENT}} / SG_{\text{CEMENT}} * D_{\text{WATER}} \\
 V_{\text{SCM}} &= W_{\text{SCM}} / SG_{\text{SCM}} * D_{\text{WATER}} \\
 V_{\text{ADMIXTURE}} &= V_{\text{ADMIXTURE in oz.}} / 957.5 \text{ oz. per cf} \\
 V_{\text{WATER}} &= V_{\text{WATER in gal.}} / 7.48 \text{ gal. per cf} \\
 V_{\text{COARSE}} &= W_{\text{COARSE}} / SG_{\text{COARSE}} * D_{\text{WATER}} \\
 V_{\text{FINE}} &= W_{\text{FINE}} / SG_{\text{FINE}} * D_{\text{WATER}} \\
 V_{\text{CONCRETE}} &= V_{\text{CEMENT}} + V_{\text{SCM}} + V_{\text{ADMIXTURE}} + V_{\text{WATER}} + V_{\text{COARSE}} + V_{\text{FINE}} + V_{\text{AIR}}
 \end{aligned}$$

^[2] The paste content by volume of cement concrete is determined by the following equation, where V = Volume (cf) and PC = Paste Content (%).

$$\begin{aligned}
 V_{\text{PASTE}} &= V_{\text{CEMENT}} + V_{\text{SCM}} + V_{\text{ADMIXTURE}} + V_{\text{WATER}} \\
 PC_{\text{CONCRETE}} &= V_{\text{PASTE}} / V_{\text{CONCRETE}}
 \end{aligned}$$

^[3] The cracking tendency of structural concrete is significantly reduced when the paste content by volume is less than or equal to 28 percent.

^[4] The paste content to aggregate void content ratio is determined by the following equation, where D = Density (pcf), SG = Specific Gravity, BD = Bulk Density (pcf), VC = Void Content (%), V = Volume (cf), AVC = Aggregate Void Content (%), PC = Paste Content (%), and R = Ratio. Workability increases as the paste content to aggregate void content ratio increases. Decreased paste content to aggregate void content ratios will result in decreased workability, where water-reducing admixtures provide no benefit.

$$\begin{aligned}
 V_{\text{COARSE}} &= SG_{\text{COARSE}} * D_{\text{WATER}} - BD_{\text{COARSE}} / D_{\text{COARSE}} \\
 V_{\text{FINE}} &= SG_{\text{FINE}} * D_{\text{WATER}} - BD_{\text{FINE}} / D_{\text{FINE}} \\
 V_{\text{AGGREGATE}} &= [(V_{\text{COARSE}} / (V_{\text{COARSE}} + V_{\text{FINE}})) * VC_{\text{COARSE}} + (V_{\text{FINE}} / (V_{\text{COARSE}} + V_{\text{FINE}})) * VC_{\text{FINE}}] \\
 AVC_{\text{CONCRETE}} &= [V_{\text{AGGREGATE}} * ((V_{\text{COARSE}} + V_{\text{FINE}}) / V_{\text{CONCRETE}})]
 \end{aligned}$$

$$R_{PC-AVC} = PC_{CONCRETE} / AVC_{CONCRETE}$$

^[5] The excess paste content for workability is determined by the following equation, where PC = Paste Content (%), AC = Air Content (%), AVC = Aggregate Void Content (%), and EPC = Excess Paste Content for Workability (%).

$$EPC_{CONCRETE} = PC_{CONCRETE} + AC_{CONCRETE} - AVC_{CONCRETE}$$

C. Initial Curing Materials.

The materials and procedures used for initial curing methods of cement concrete shall meet the Manufacturer's instructions and recommendations and the requirements specified herein.

Cement concrete with a low to negligible bleeding rate, exposure to highly evaporative environments, high content of silica fume, fine cement, or other fine cementitious material, low water to cementitious ratio, high air content, or water-reducing admixtures have an increased susceptibility to surface drying and plastic shrinkage between placement and finishing operations. Initial curing materials and procedures shall be applied immediately after the bleed water sheen has disappeared from the surface of the concrete or the concrete surface exhibits loss of moisture and surface drying, between placement and finishing operations. Initial curing materials shall not be worked into the surface in subsequent finishing operations.

1. Liquid-Applied Evaporation Reducers.

Liquid-applied evaporation reducers used for initial curing methods shall produce an effective monomolecular film over the bleed water layer, to reduce the rate of evaporation of the bleed water from the surface and plastic shrinkage when the evaporation rate equals or exceeds the bleeding rate.

D. Intermediate Curing Materials.

The materials and procedures used for intermediate curing methods of cement concrete shall meet the Manufacturer's instructions and recommendations and the requirements specified herein.

In instances where finishing operations have been completed prior to the concrete achieving final set and the concrete surface exhibits loss of moisture and surface drying, the following curing materials and procedures shall be applied immediately to the concrete surface prior to the application of final curing materials, to prevent the loss of moisture without damaging the concrete surface, until final set of the concrete has been achieved and final curing materials have been applied to the concrete surface.

- 701.30.C.1: Liquid-Applied Evaporation Reducers
- 701.30.E.3.a: Liquid Membrane-Forming Compounds for Curing
- 701.30.E.3.b: Liquid Membrane-Forming Compounds for Curing and Sealing

E. Final Curing Materials.

The materials and procedures used for final curing methods of cement concrete shall meet the Manufacturer's instructions and recommendations and the requirements specified herein.

Curing water shall be free of deleterious impurities, causing staining and deterioration. The potential staining ability of curing water shall be evaluated by means of CRD-C401 (US Army Corps

of Engineers 1975) for instances where curing water quality is questioned. Curing water shall not exceed a temperature differential of more than 20°F from the internal concrete temperature, to prevent cracking due to temperature gradients causing strain that exceeds the strain capacity of concrete. Curing water shall remain above freezing temperatures throughout the duration of the curing cycle.

Final curing materials and procedures shall be applied to the concrete surface immediately after application of initial and intermediate curing materials, finishing operations, and final set of cement concrete, to prevent the loss of moisture and surface drying.

Materials used for final curing methods of cement concrete shall accommodate all exposed cement concrete surfaces with a continuous application of moisture throughout the entire duration of the final curing method cycle and provide controlled and gradual termination of the final curing method cycle.

Final curing materials applied to the concrete shall allow the concrete to mature sufficiently to achieve its designed and desired properties, including strength, volume stability, permeability, durability, and resistance to freezing, thawing, and de-icing cycles. Insufficient application of final curing materials results in decreased strength and durability of the top surface of concrete.

Protection to the concrete surface and curing materials shall be required in instances where adverse weather conditions are present, until curing operations can be initiated without damaging the surface of the concrete.

Final curing materials and procedures shall be applied to the concrete surface throughout the entire duration of the curing cycle and meet minimum sustained temperature, duration, and strength requirements, as specified in applicable Division II: Construction Details and herein. Controlled and gradual termination of the final curing method cycle shall begin only after all specified conditions are met, until the concrete gradually cools to within 20°F of the ambient temperature.

1. Saturated Covers.

Saturated covers used for final curing methods shall meet AASHTO M 182, Class 3. Saturated covers shall be in good condition, free from holes, tears, or other defects that would render it unsuitable for curing cement concrete and cementitious materials. Saturated covers shall be dried to prevent mildew when storing. Prior to application, saturated covers shall be thoroughly rinsed in water and free of harmful substances that are deleterious or cause discoloration to cement concrete and cementitious materials. Saturated covers shall have sufficient thickness and proper positioning onto the surface to maximize moisture retention. Saturated covers shall contain a sufficient amount of moisture to prevent moisture loss from the surface of cement concrete and cementitious materials. Saturated covers shall have the ability to retain sufficient moisture from continuous watering so that a film of water remains on the surface of cement concrete and cementitious materials throughout the entire duration of the final curing method cycle. Saturated covers shall not absorb water from cement concrete and cementitious materials. Polyethylene film may be applied over the saturated cover to limit the amount of continuous watering required for sufficient moisture retainage. Saturated covers shall accommodate uniform and slow drying of cement concrete and cementitious materials surfaces immediately prior to removal.

2. Sheet Materials.

Sheet materials, including polyethylene film, white burlap-polyethylene sheeting, and reinforced paper, used for final curing methods shall meet ASTM C171 and the requirements specified herein. Sheet materials shall inhibit moisture loss and reduce temperature rise in concrete exposed to radiation from the sun during the final curing method cycle. Adjoining covers shall overlap not less than 12 inches. All edges of the sheet materials shall be secured to maintain a moist environment.

a. Polyethylene Film.

Polyethylene film shall be clear, white, or black in color and consist of a single sheet manufactured from polyethylene resins, be free of visible defects, including tears, wrinkles, and discontinuity. The film shall prohibit mottling and uneven spots from appearing on the surface of concrete, due to variations in temperature, moisture content, or both. Application of additional curing water under the film or application of a polyethylene film bonded to absorbent fabric to the concrete surface may be required to prevent mottling and to retain and evenly distribute the moisture. Polyethylene film shall accommodate concrete surfaces with constant contact without damage. The film shall be sufficient in length to extend beyond the edges of the concrete surface. Edges of adjacent polyethylene film shall overlap a minimum of 6 inches and be tightly sealed with the use of sand, wood planks, pressure-sensitive tape, mastic, or glue to maintain close contact with the concrete surface, retain moisture, and prevent the formation of air pockets throughout the entire duration of the final curing method cycle.

i. White Polyethylene Film.

White polyethylene film shall minimize heat gain caused by absorption of solar radiation and shall be exclusively used during warm weather applications.

ii. Clear and Black Polyethylene Films.

Clear and black polyethylene films shall inhibit absorption of solar radiation for cold weather applications.

b. White Burlap-Polyethylene Sheeting.

White burlap-polyethylene sheeting shall be securely bonded to the burlap so to avoid separation of the materials during handling and curing of the concrete.

c. Reinforced Impervious Paper.

Reinforced impervious paper shall be white in color, consist of two sheets of kraft paper cemented together with a bituminous adhesive, and reinforced with embedded cords or strands of fiber running in both directions. Reinforced impervious paper shall be free of holes, tears, and pin holes from deterioration of the paper through repeated use. Reinforced impervious paper shall be treated to prevent tearing when wetted and dried. Reuse of reinforced impervious paper shall be permitted so long as it is able to retain moisture on the surface of concrete. The paper shall be discarded and prohibited from use when moisture is no longer retained in the material.

3. Liquid Membrane-Forming Compounds.

Compounds shall form a continuous, non-yellowing, and durable film with quality moisture-retention properties. Compounds shall maintain the relative humidity of the concrete surface

above 80% for seven days to sustain cement hydration. Compounds shall not affect the original color of the concrete surface. Compounds shall not degrade due to exposure to ultraviolet light from direct sunlight. Compounds shall meet the local and federal allowable Volatile Organic Compound (VOC) content limits.

White-pigmented compounds shall be used in instances where solar-heat gain is concern to the concrete surface. White-pigmented compounds shall be agitated in the container prior to application to prevent pigment from settling out resulting in non-uniform overage and ineffective curing.

Careful considerations shall be made by the Contractor to determine if the evaporation rate is exceeding the rate of bleeding, thus causing the surface to appear dry even though bleeding is still occurring. To diagnose and prevent this condition, the Contractor may place a transparent plastic sheet over a test area of the uncured and unfinished concrete surface and shall determine if any bleed water accumulates under the plastic. Under such conditions, the application of liquid membrane-forming compounds to the concrete surface shall be delayed to prevent bleed water from being sealed below the concrete surface, map cracking of the membrane films, reduction in moisture-retention capability, and the need for reapplication of the compound.

Prior to use, compounds shall be thoroughly mixed, stirred, and agitated per the Manufacturer's instructions and recommendations.

Compounds shall be applied continuously and uniformly to the surface of the concrete per the Manufacturer's instructions and recommendations. Compounds shall be applied immediately after the disappearance of the surface water sheen following final finishing. Applying of the compound immediately after final finishing and before all free water on the surface has evaporated will help prevent the formation of cracks. When using compounds to reduce moisture loss from formed surfaces, the exposed surface shall be wetted immediately after form removal and kept moist until the curing compound is applied. The concrete shall be allowed to reach a uniformly damp appearance with no free water on the surface, and then application of the compound shall begin at once. Delayed application will result in surface drying, absorption of the compound into the concrete, and no forming of a continuous membrane.

The concrete surface shall be damp when the compound is applied. Power-driven spray equipment shall be used for uniform application of compounds on large paving projects. Spray nozzles recommended by the compound Manufacturer and use of windshields shall be arranged by the Contractor to prevent wind-blown loss of compound and to ensure proper coverage application rates are achieved. The compound shall be applied by power sprayer, using appropriate wands and nozzles with pressures between 25 and 100 psi. The Contractor shall fill the power sprayer with curing compound from the Manufacturer's original container in the presence of the Engineer. Any dilution as recommended by the Manufacturer shall take place in the presence of the Engineer. For very small areas such as repairs, the compound shall be applied with a wide, soft-bristled brush or paint roller.

The Contractor shall verify the application rate and procedures are in accordance with the Manufacturer's instructions and recommendations. At least one uniform coat shall be applied at a rate of 150 to 200 ft²/gallon. On very deeply textured surfaces, the surface area to be treated shall be at least twice the surface area of the surface. In such cases, two separate applications may be needed, each at 200 ft²/gallon or greater if specified by the Manufacturer to achieve the desired

moisture retention rate, with the first being allowed to become tacky before the second is applied. If two coats are necessary to ensure complete coverage, for effective protection the second coat should be applied at right angles to the first. Complete coverage of the surface shall be attained due to the potential for formation of small pinholes in the membrane, which will result in loss of moisture from the concrete. Compounds shall not sag, run off peaks, or collect in grooves.

Compounds and procedures shall be compatible with concrete surfaces receiving subsequent applications or placements of concrete, overlays, coatings, paints, sealers, finishes or other toppings to ensure acceptable bonding to the concrete. Testing to establish compatibility among the curing compound, subsequent surface treatments, concrete moisture content and the actual finished surface texture of the concrete shall be conducted when compatibility is not known. The compound Manufacturer shall be consulted by the Contractor to determine the compatibility of the application. Compounds shall not be applied to concrete surfaces where bonding of subsequent applications or placements is incompatible or is of concern. The use of wax-based curing compounds shall be prohibited in instances where concrete surfaces are subject to additional toppings and vehicular, pedestrian, or other traffic. Deliberate removal of compounds in the presence of the Engineer and in accordance with Manufacturer's instructions and recommendations shall be conducted as an alternative to compatibility testing, incompatibility, or in instances where bonding is of concern. Bonding of subsequent materials may still be inhibited by the presence of the compound even after the moisture retention characteristics of the compound have diminished.

a. Liquid Membrane-Forming Compounds for Curing.

Liquid membrane-forming compounds for curing shall meet ASTM C309, the Manufacturer's instructions and recommendations, and the requirements specified herein.

Table 701.30-1: Types of Compounds for Curing

Type	Description
Type 1	Clear or translucent without dye
Type 1-D	Clear or translucent with fugitive dye
Type 2	White pigmented

Table 701.30-2: Composition Class of Compounds for Curing

Type	Description
Class A	Unrestricted composition, generally wax-based products
Class B	ASTM D883 resin-based products

b. Liquid Membrane-Forming Compounds for Curing and Sealing.

Liquid membrane-forming compounds for curing and sealing shall meet ASTM C 1315, the Manufacturer's instructions and recommendations, and the requirements specified herein.

In addition to moisture-retention capabilities compounds shall exhibit specific properties, including alkali resistance, acid resistance, adhesion-promoting quality, and resistance to degradation by ultraviolet light.

Table 701.30-3: Types of Compounds for Curing and Sealing

Type	Description
Type I	Clear or translucent
Type II	White pigmented

Table 701.30-4: Class of Compounds for Curing and Sealing

Type	Description
Class A	Non-yellowing

F. Protective Sealing Compounds.

Protective sealing compounds shall maintain valid listing on the Department Qualified Construction Materials List (QCML) and meet AASHTO M 224, NCHRP Report 244 and the requirements specified herein.

Protective sealing compounds shall sufficiently penetrate the concrete to seal the surface pores and fill the capillaries of the concrete by chemically reacting with the concrete and forming a hydrophobic layer. Protective sealing compounds shall limit the penetration of liquids, gases, and harmful substances into hardened concrete, including water, de-icing agents, and carbon dioxide to protect concrete from freezing, thawing, and de-icing cycles, corrosion of reinforcing steel, and acid attack. Protective sealing compounds shall limit the buildup of vapor pressure between the concrete and the applied sealer. Protective sealing compounds shall retard the penetration of harmful substances into hardened concrete. Protective sealing compounds shall maintain their protective properties during environmental exposure to freezing, thawing, and de-icing cycles. Protective sealing compounds shall not reduce the frictional properties of the concrete. Protective sealing compounds shall not affect the original color of the concrete surface if maintaining the original color is desired by the Department. Protective sealers shall meet the local and federal allowable Volatile Organic Compound (VOC) content limits.

Curing methods conforming to Department specifications shall be applied to the concrete prior to the application of protective sealers. Protective sealers shall not be applied to the concrete for a minimum of 28 days after placement and the surface shall be sufficiently prepared, clean, and dry for at least 24 hours with ambient temperatures exceeding 60°F. Protective sealers shall not be applied to concrete placed where freezing, thawing, and de-icing cycles are expected immediately after, due to the retainage of water in the concrete. Periodic re-application shall be required for protective penetrants requiring multiple applications and for concrete surfaces exhibiting wear to ensure long-term protection of the concrete surface.

G. Cold Weather Concreting Materials.

Cold weather concreting shall be defined as the procedures, operations, materials, and equipment required for the mixing, delivery, placement, finishing, curing, and protection of concrete during cold weather conditions, while exposed to air temperatures falling below, or expected to fall below 40°F.

The protection period shall be defined as the minimum duration required to prevent concrete from the negative effects of cold weather exposure. The protection period shall remain in place while

cold weather conditions exist. Controlled and gradual termination of the protection period shall be conducted only after 100% f'c is attained and all specified conditions are met.

The procedures, operations, materials, and equipment selected for cold weather concreting shall adequately maintain specified temperature ranges by addressing all variables, including ambient weather conditions, geometry of the structure, and mix design proportions. Concrete temperatures for cold weather concreting shall meet Table 701.30-5.

Table 701.30-5: Concrete Temperature Requirements for Cold Weather Concreting

Phase	Cold Weather Temperature (°F)	Concrete Temperature (°F)
Mixing	30-39	60-75
	0-30	65-80
	< 0	70-85
Placement	< 40	55-75
Protection Period	< 40	55-75
Termination of Protection Period – Allowable Rate of Decrease in 24 Hours	< 40	≤ 50

Cold weather concreting procedures, operations, materials, and equipment shall be developed and performed to prevent damage to concrete due to freezing at early ages, to ensure that the concrete develops the recommended strength for safe removal of forms, to maintain curing conditions that promote quality strength and durability development, to limit rapid temperature fluctuation, and to provide protection consistent with intended serviceability of the structure. The Contractor shall develop and submit to the Department for review and approval, cold weather concreting procedures for the mixing, delivery, placement, finishing, curing, and protection of concrete during cold weather, including:

- Procedures for protecting the subgrade from frost and the accumulation of ice or snow on reinforcement or forms prior to placement
- Methods and requirements for cold weather protection and temperature control of constituent materials incorporated into the mix design
- Chemical admixtures incorporated into the mix design for cold weather protection and temperature control
- Methods and requirements for cold weather protection and temperature control during mixing, delivery, placement, finishing, curing, and protection period
- Curing methods to be used during and following the protection period
- Types of covering, insulation, heating, or enclosures to be provided
- Methods for verification of in-place strength
- Procedures for measuring and recording concrete temperatures
- Procedures for preventing drying during dry, windy conditions

All procedures, operations, materials, and equipment required for adequate protection and curing shall be present and ready for use prior to concrete production.

1. Insulating Materials.

Insulating materials used for cold weather concreting shall meet the requirements specified herein. The thermal resistance of the proposed insulation system shall be determined to meet the concrete temperature range requirements specified herein. Supplemental heat, including hydronic heating systems, shall be applied in instances where insulating materials cannot achieve the concrete temperature requirements.

2. Heaters.

Heaters used for cold weather concreting including direct fired, indirect fired, and hydronic heaters shall meet ANSI A10.10 carbon monoxide limits, safety regulations for ventilation, and the stability, operation, fueling, and maintenance of heaters and the requirements specified herein.

a. Direct Fired Heaters.

Direct fired heaters generate heat to an enclosed space through the combustion of fossil fuels, including oil, kerosene, propane, gasoline, and natural gas. Hot air comprised of carbon dioxide and carbon monoxide combustion products, is discharged into the enclosed space. Direct fired heaters shall be prohibited from heating the air directly surrounding the concrete surface due to calcium carbonate formation interfering with the hydration reaction, from the reaction between the carbon dioxide generated from the combustion of fossil fuels and the calcium hydroxide on the surface of freshly placed concrete, resulting in a soft, chalky, and nondurable concrete surface. Direct fired heaters shall only be used on concrete surfaces protected from fossil fuel combustion products.

b. Indirect Fired Heaters.

Indirect fired heaters generate heat to an enclosed space through the combustion of fossil fuels, including oil, kerosene, propane, gasoline, and natural gas. The carbon dioxide and carbon monoxide combustion products are expelled through venting, resulting in clean heated air discharged into the enclosed space. Indirect fired heaters are suitable for heating the air directly surrounding the concrete surface.

c. Hydronic Heaters.

Hydronic heaters generate heat to an enclosed space through the circulation of the heat-transfer fluid in a closed system of pipes or hoses. The heat-transfer fluid is comprised of a propylene glycol water solution and is heated through the combustion of fossil fuels, including diesel fuel and kerosene. The combustion of fossil fuel occurs outside of the enclosed space and does not expose the concrete surface to the deleterious effects of carbon dioxide.

After the concrete placement achieves final set, polyethylene film or other suitable material shall sufficiently serve as a vapor barrier. The heat-transfer hoses shall be placed on top of the vapor barrier and covered with insulating materials meeting 701.30.G.1. Hydronic heaters shall be used to thaw or preheat subgrades prior to concrete placement and provide supplementary heat to insulating materials. Hydronic heaters shall provide an even distribution of heat to prevent curling and cracking induced by temperature gradients within concrete.

3. Enclosures.

Enclosures shall be made of wood, canvas tarpaulins, polyethylene film, or prefabricated rigid plastic. Enclosures shall be airtight, block wind, prevent admittance of cold air, conserve heat, and withstand wind and snow loads. Enclosures shall provide adequate headroom for craftsmen and sufficient space between the concrete and the enclosure to permit free circulation of warm air. Supplementary heat shall be supplied to enclosures by hydronic heaters, live steam, hot forced air, or indirect fired combustion heaters. Icing along the perimeter of the enclosure shall be prevented when live steam is utilized. Heaters and ducts shall be positioned to prevent the hot, dry air from overheating or drying the concrete surface. Insulating materials meeting 701.30.G.1 shall be applied as a vapor barrier to the concrete surface immediate after final set is attained.

H. Hot Weather Concreting Materials.

Hot weather concreting shall be defined as the procedures, operations, materials, and equipment required for the mixing, delivery, placement, finishing, bleed water evaporation, curing, and protection of concrete during hot weather conditions, while exposed to air temperatures exceeding, or expected to exceed 80°F; concrete temperatures approaching, or expected to approach 90°F; evaporation rates of surface water approaching, or expected to approach the bleeding rate of the concrete; high solar radiation; low relative humidity; and high wind speed.

The protection period shall be defined as the minimum duration required to prevent concrete from the negative effects of hot weather exposure, including the acceleration of rate of moisture loss and rate of cement hydration, difficulties in curing, increased concrete temperature, increased water demand, accelerated slump loss, increased rate of setting, increased tendency for plastic shrinkage and thermal cracking, increased potential for cold joints, and difficulties in controlling entrained air content. The protection period shall remain in place while hot weather conditions exist. Controlled and gradual termination of the protection period shall be conducted when conditions permit. The allowable rate of temperature decrease shall not exceed 5°F per hour and meet the allowable rate of temperature decrease specified in 701.30.G: Cold Weather Concreting Materials.

The procedures, operations, materials, and equipment selected for hot weather concreting shall adequately maintain specified temperature ranges and evaporation rates by addressing all variables, including ambient weather conditions, geometry of the structure, and mix design proportions. Initial materials meeting 701.30.C: Initial Curing Materials shall be applied to the concrete surface while the concrete and air temperatures, relative humidity of the air, and the wind speed have the capacity to evaporate free water from the fresh concrete surface at a rate that is equal to or greater than bleeding rate of the concrete. The evaporation rate of surface water shall be determined by the following equation:

$$E = (T_c^{2.5} - r * T_a^{2.5})(1 + 0.4V) \times 10^{-6}$$

where E = evaporation rate of water-covered surface (lb/ft²/hr), T_c = concrete temperature of the evaporating surface (°F), r = relative humidity of air surrounding the evaporating surface (%), T_a = temperature of the air surrounding the evaporative surface (°F), and V = average wind speed 20 inches above the evaporating surface. The air surrounding the evaporating surface shall be defined as the air approximately 4 to 6 feet above the evaporating surface on the windward side and shielded from the sun's rays.

Hot weather concreting procedures, operations, materials, and equipment shall be developed and performed to prevent damage to concrete and promote long-term durability. The Contractor shall develop and submit to the Department for review and approval, hot weather concreting procedures for the mixing, delivery, placement, finishing, curing, and protection of concrete during hot weather, including:

- Procedures for preparing the subgrade prior to placement
- Methods and requirements for hot weather protection and temperature control of constituent materials incorporated into the mix design
- Chemical admixtures incorporated into the mix design for hot weather protection and temperature control
- Methods and requirements for hot weather protection and temperature control during mixing, delivery, placement, finishing, curing, and protection period
- Initial curing methods to be used to reduce surface evaporation
- Curing methods to be used during and following the protection period
- Types of covering, insulation, cooling, or enclosures to be provided
- Evaporation rate and bleeding rate of concrete calculations
- Procedures for measuring and recording concrete temperatures
- Procedures for preventing drying during dry, windy conditions

All procedures, operations, materials, and equipment required for adequate protection and curing shall be present and ready for use prior to concrete production.

CONSTRUCTION METHODS

701.40: Pre-Placement

A. Excavation.

Excavation of the area shall be in accordance with the applicable portions of Subsection 120: Excavation.

B. Subgrade and Subbase.

The subgrade for the sidewalks and driveways shall be shaped parallel to the proposed surface of the sidewalks and driveways and thoroughly compacted. All depressions in the subgrade shall be filled with suitable material and again compacted until the surface is smooth and hard. Prior to the placement of the subbase, the Contractor shall inspect the prepared subgrade to ensure that it is in conformance with the required grade and cross-section. Subgrade shall be fine graded to meet the applicable requirements of Subsection 170: Grading.

After the subgrade has been prepared, a gravel subbase shall be placed upon it. After being compacted thoroughly, the subbase shall be at least 8 inches thick and parallel to the proposed surface of the sidewalk. Prior to the placement of the cement concrete, the Contractor shall inspect the prepared subbase material to ensure that it is in conformance with the required grade and cross-section. Subbase material that is not in accordance with the plans or specifications shall be reworked or replaced to meet the applicable requirements of Subsection 170: Grading before the start of cement concrete placement. When placing cement concrete, the compacted subbase shall not be frozen or have standing water.

C. Forms.

Side forms and transverse forms shall be smooth, free from warp, of sufficient strength to resist springing out of shape, of a depth to conform to the thickness of the proposed sidewalk or pedestrian curb ramp and of a type satisfactory to the Engineer.

All mortar or dirt from previously used forms shall be completely removed prior to use. The forms shall be well staked and thoroughly graded and set to the established lines with their upper edge conforming to the grade of the finished sidewalk or pedestrian curb ramp which shall have sufficient pitch to the roadside edge to provide for surface drainage.

All pedestrian curb ramp joints and transition sections which define grade changes shall be formed staked and checked for dimension, grade and slope conformance prior to placing cement concrete.

All forms shall be oiled before placing concrete.

701.41: Placement

The concrete shall be placed in alternate slabs 30 ft long except as otherwise ordered. The slabs shall be separated by transverse preformed expansion joint filler ½ in. thick.

Preformed expansion joint filler shall be placed adjacent to or around existing structures as directed.

Detectable warning panels conforming to the plans shall be securely incorporated into the work by means acceptable to the Engineer.

On the foundation as specified above, the concrete shall be placed in such quantity that after being thoroughly consolidated in place it shall be 4 in. deep. At driveways, the sidewalks shall be 6 in. deep.

In conveying the concrete from the place of mixing to the place of deposit, the operation shall be conducted in such a manner that no mortar will be lost, and the concrete shall be so handled that the concrete will be of uniform composition throughout, showing neither excess nor lack of mortar in any one place.

The surface of all concrete sidewalks shall be uniformly scored into block units of areas not more than 36 ft². The depth of the scoring shall be at least ½ in. deep and no more than ½ in. wide.

701.42: Initial Curing

In instances where the bleed water sheen has disappeared from the surface of the concrete or the concrete surface exhibits loss of moisture and surface drying between placement and finishing operations, the Contractor shall apply one of the following initial curing materials and procedures meeting 701.30.C: Initial Curing Materials until finishing operations occur.

- 701.30.C.1: Liquid-Applied Evaporation Reducers

Initial curing materials shall not be worked into the surface in subsequent finishing operations.

701.43: Finishing

The finishing of concrete surface shall be done by experienced and competent cement finishers. No finishing operation shall be performed while free water is present. Finishing operations shall be delayed until all bleed water and water sheen has left the surface and the concrete has started to stiffen. After water sheen has disappeared, edging operations, where required, shall be completed. After edging and joining operations, the surface shall be floated. Magnesium floats shall be used for all finishing operations. If necessary tooled joints and edges shall be rerun before and after floating to maintain uniformity. After floating, the surface shall be brushed by drawing a soft-bristled push broom with a long handle over the surface of the concrete to produce a nonslip surface.

701.44: Intermediate Curing

In instances where finishing operations have been completed prior to the concrete achieving final set and the concrete surface exhibits loss of moisture and surface drying, the Contractor shall apply one of the following intermediate curing materials and procedures meeting 701.30.D: Intermediate Curing Materials immediately to the concrete surface prior to the application of final curing materials, to prevent the loss of moisture without damaging the concrete surface, until final set of the concrete has been achieved and final curing materials have been applied to the concrete surface.

- 701.30.C.1: Liquid-Applied Evaporation Reducers
- 701.30.E.3.a: Liquid Membrane-Forming Compounds for Curing
- 701.30.E.3.b: Liquid Membrane-Forming Compounds for Curing and Sealing

701.45: Final Curing

The Contractor shall apply one of the following final curing materials and procedures meeting 701.30.E: Final Curing Materials to the concrete surface immediately after application of initial and intermediate curing materials, finishing operations, and final set of cement concrete, to prevent the loss of moisture and surface drying.

- 701.30.E.1: Saturated Covers
- 701.30.E.2: Sheet Materials
- 701.30.E.3.a: Liquid Membrane-Forming Compounds for Curing
- 701.30.E.3.b: Liquid Membrane-Forming Compounds for Curing and Sealing

The Contractor shall apply final curing materials and procedures to the concrete surface throughout the entire duration of the curing cycle and meet minimum sustained temperature, duration, and strength requirements, as specified in in Table 701.45-1. Controlled and gradual termination of the curing cycle shall begin after all specified conditions are met.

Table 701.45-1: Termination of Curing Cycle

Sustained Concrete Temperature	Final Curing Cycle Duration	Compressive Strength ^[1]
50°F ≤ °F ≤ 90°F	≥ Seven (7) days	≥ 70% f _c

^[1] Compressive strength cylinders for termination of curing cycle shall be cast and field cured with the same environmental conditions that the sidewalk is subjected to throughout the entire duration of the final curing cycle, per 701.73: Acceptance Sampling and Testing.

701.46: Protective Sealing

The Contractor shall apply sealing materials and procedures meeting 701.30.F: Protective Sealing Compounds only if one or more of the following final curing materials and procedures were applied:

- 701.30.E.1: Saturated Covers
- 701.30.E.2: Sheet Materials
- 701.30.E.3.a: Liquid Membrane-Forming Compounds for Curing

Protective sealing compounds shall not be applied to concrete surfaces applied with a final curing material and procedure meeting 701.30.E.3.b: Liquid Membrane-Forming Compounds for Curing and Sealing.

701.47: Cold Weather Concreting

The Contractor shall conduct cold weather concreting procedures, operations, materials, and equipment required for the mixing, delivery, placement, finishing, curing, and protection of concrete, while surfaces are exposed to air temperatures falling below, or expected to fall below 40°F in accordance with 701.30.G: Cold Weather Concreting Materials. All procedures, operations, materials, and equipment required for adequate protection and curing shall be present and ready for use prior to concrete production.

701.48: Hot Weather Concreting

The Contractor shall conduct hot weather concreting procedures, operations, materials, and equipment required for the mixing, delivery, placement, finishing, curing, and protection of concrete, while surfaces are exposed to air temperatures exceeding, or expected to exceed 80°F; concrete temperatures approaching, or expected to approach 90°F; evaporation rates of surface water approaching, or expected to approach the bleeding rate of the concrete; high solar radiation; low relative humidity; and high wind speed in accordance with 701.30.H: Hot Weather Concreting Materials. All procedures, operations, materials, and equipment required for adequate protection and curing shall be present and ready for use prior to concrete production

CONTRACTOR QUALITY CONTROL**701.60: General**

The Contractor shall provide adequate Quality Control (QC) to ensure that all materials and workmanship conform with the specification requirements. The Contractor shall perform QC activities as outlined further below.

701.61: Contractor Quality Control Plan

The Contractor shall provide and maintain a Quality Control Plan (QC Plan). The QC Plan should sufficiently document the QC processes of all Contractor parties (i.e. Prime Contractor, Subcontractors, Producers) performing work required under this specification.

701.62: Production Personnel

A. Foreman.

A foreman shall be present throughout the entire duration of the construction operation with at least one of the following personnel certifications.

- NRMCA Concrete Exterior Finisher Certification
- ACI Concrete Flatwork Technician and Flatwork Finisher

The foreman is responsible for the oversight of the construction operation per the requirements specified in Table 701.62-1.

Table 701.62-1: Minimum Foreman Activities

Operation	Foreman	Activity
Oversight	One (1)	Review and compare batch ticket quantities and sources to approved mix design
		Monitors conformance to AASHTO M 157 Standard Specification for Ready-Mixed Concrete
		Monitors conformance to Department specifications
		Monitors Production Personnel activities
		Verifies proper equipment is on hand prior to start of construction
		Monitors equipment, environmental conditions, materials, and workmanship
		Prohibits the use of prohibited equipment and practices
		Acknowledges sampling, testing, and inspection results

B. Operators.

Concrete sidewalk shall be constructed by sufficiently staffed, trained, experienced, and qualified equipment operators and craftsmen, who are presently involved in sidewalk construction, throughout the entire duration of the construction operation, per the requirements specified in Table 701.62-2.

Table 701.62-2: Minimum Operator Activities

Operation	Operators^[1]	Activity
701.40: Pre-Placement	Two (2)	Apply sufficient base compaction
		Moisten sub-base, free of standing water
		Secure forms, straight and level
		Mark expansion locations
		Prohibited Practices: Placement on frozen sub-grade
701.41: Placement (Concrete Discharging)	Two (2)	Direct concrete trucks
		Handle chute discharge and truck movement
		Assist in preparing concrete for testing
		Direct trucks to washout area
		Provide general help
		Prohibited Practices: Adding constituent materials not in conformance with AASHTO M 157 or without Department consent
701.41: Placement	Two (2)	Localize placement to minimize moving material
		Level concrete in front of the screed
		Operate come-alongs or flat headed shovel to move concrete in form
		Consolidate concrete along form edge to avoid honeycombing
		Operate screed over top of forms in sawing action for surface leveling
		Operate magnesium bull float to push coarse aggregate below the surface and fill in the low spots or depressions
		Prohibited Practices: Toothed raking, dragging of internal vibrator, and internal vibrator to move concrete; steel troweling or floating
701.42: Initial Curing	Apply an initial curing material and procedure per 701.42	
	One (1)	701.30.C.1: Liquid-Applied Evaporation Reducers
701.43: Finishing	Two (2)	Permit bleed water to dissipate and concrete to set
		Operate a hose drag or squeegee to remove water from the surface
		Check surface for flatness, fill/cut as necessary
		Finish surface with magnesium float
		Apply pulled broom finish at proper time to acceptable texture
		Clean broom when excessive mortar adheres
		Remove excess water from broom before use
		Finish edges and joints
		Finish well formed, properly spaced joints to sufficient depth
Prohibited Practices: Steel troweling or floating; adding water to the surface; excessive working of surface; pushing broom across surface		

^[1] Recommended number of operators.

Table 701.62-2: Minimum Operator Activities (Continued)

Operation	Operators ^[1]	Activity
701.44: Intermediate Curing	If applicable, apply an intermediate curing material and procedure per 701.44	
	One (1)	701.30.C.1: Liquid-Applied Evaporation Reducers
	One (1)	701.30.E.3.a: Liquid Membrane-Forming Compounds
	One (1)	701.30.E.3.b: Liquid Membrane-Forming Compounds for Curing and Sealing
701.45: Final Curing	Apply a final curing material and procedure meeting 701.45	
	Four (4)	701.30.E.1: Saturated Covers
	Four (4)	701.30.E.2: Sheet Materials
	One (1)	701.30.E.3.a: Liquid Membrane-Forming Compounds
	One (1)	701.30.E.3.b: Liquid Membrane-Forming Compounds for Curing and Sealing
701.46: Protective Sealing	One (1)	If applicable, apply a protective sealing material and procedure per 701.46
701.47: Cold Weather Concreting	Four (4)	If applicable, apply cold weather concreting materials and procedures per 701.47 and the Department approved Contractor cold weather concreting plan
701.48: Hot Weather Concreting	Four (4)	If applicable, apply hot weather concreting materials and procedures per 701.48 and the Department approved Contractor hot weather concreting plan

^[1] Recommended number of operators.

701.63: Quality Control Inspection

Quality Control inspection shall be performed and reported on inspection report forms by qualified Quality Control Technicians, to confirm conformance to specifications and to visually inspect equipment, environmental conditions, materials, and workmanship. Quality Control Technicians shall obtain at least one of the following personnel certifications.

- NRMCA Concrete Exterior Finisher Certification
- ACI Concrete Flatwork Technician and Flatwork Finisher

Quality Control inspection report forms shall be completed by the Contractor and submitted to the Department for review.

DEPARTMENT ACCEPTANCE

701.70: General

Acceptance shall be performed by the Department, including consultants under direct contract with the Department independent of the Contractor, to evaluate the degree of compliance with contract requirements, to monitor each Contractor entity’s Quality Control activities, to determine the

corresponding value for a given product, and to determine the acceptability of all material produced and placed.

701.71: Acceptance of Contractor Quality Control Plan

The Department will review the Contractor Quality Control Plan. Department approval shall be subject to conformance with the requirements specified herein.

701.72: Acceptance Inspection

Acceptance inspection will be performed and reported by qualified Department (or designee) Acceptance Technicians, to confirm conformance to specifications and to visually inspect equipment, environmental conditions, materials, and workmanship.

701.73: Acceptance Sampling and Testing

Acceptance sampling and testing will be performed and reported by qualified Department (or designee) Acceptance Technicians, to provide quality characteristic data used for Department Acceptance determination, per the requirements specified herein.

Table 701.73-1: Minimum Acceptance Sampling and Testing Requirements

Property	Method	Quality Characteristic	Sublot Size	Minimum Test Frequency	Point of Sampling	Criteria
Uniformity	T 119	Slump Allowable Tolerance (in.) ^[1]	100 cy	1 per Sublot	Point of Discharge	Target \pm 1.5
Workability	T 119	Segregation Resistance ^[2]	100 cy	1 per Sublot	Point of Discharge	Pass
Thermal	T 309	Concrete Temperature ($^{\circ}$ F)	100 cy	1 per Sublot	Point of Discharge	50 – 90
Strength	T 22	Compressive Strength at 7 Days for Curing Termination (psi) ^[3]	100 cy	1 per Sublot	Point of Discharge	\geq 70% f'_c
		Compressive Strength at 28 Days (psi) ^[3]	100 cy	1 per Sublot	Point of Discharge	\geq 100% f'_c
		Compressive Strength at 56 Days (psi) ^{[3][4]}	100 cy	1 per Sublot	Point of Discharge	\geq 100% f'_c
Durability	T 121 T 152 T 196	Freezing and Thawing Resistance: Air Content (%)	100 cy	1 per Sublot	Point of Discharge	5.5 – 8.5
	T 303 or C1567	Alkali Silica Reaction Resistance: Expansion at 14 Days (%)	–	1 per Annual Mix Design Submission Cycle	–	\leq 0.08

^[1] Test result and the Producer's mix design target shall be within the specified allowable tolerances. Slump shall be reported on the Producer's mix design batch ticket for each delivery.

^[2] Testing for segregation resistance shall be performed while the concrete is being discharged and during AASHTO T 119 Standard Method of Test for Slump of Hydraulic Cement Concrete. Visual signs of segregation include coarse particles advancing in front of or behind the fine particles and mortar and a tendency for coarse aggregate to separate from the mortar, particularly when the mixture is being consolidated.

^[3] Three (3) 4 x 8 in. compressive strength cylinders shall be cast and tested for each age per sublot.

^[4] Testing only required if compressive strength results at 28 days do not conform with specifications.

COMPENSATION

701.80: Method of Measurement

Cement Concrete Sidewalks, Pedestrian Curb Ramps, and Driveways will be measured in square yards.

Excavation will be measured by the cubic yard as specified in 120.80: Method of Measurement.

Gravel Borrow will be measured by the cubic yard as specified in 150.80: Method of Measurement.

Fine grading and compacting will be measured by the square yard as specified in 170.88: Method of Measurement.

701.81: Basis of Payment

Cement Concrete Sidewalk, Cement Concrete Pedestrian Curb Ramp, and Cement Concrete Driveway will be paid for at the contract unit price per square yard complete in place, including detectable warning panels and all incidental materials, labor, and equipment necessary to complete the work to the satisfaction of the Engineer.

Gravel will be paid for at the contract unit price per cubic yard under Item 151: Gravel Borrow.

Fine grading and compacting will be paid for at the contract unit price per square yard under Item 170: Fine Grading and Compacting – Subgrade Areas.

Excavation will be paid for at the contract unit price per cubic yard under the excavation items.

701.82: Payment Items

701.	Cement Concrete Sidewalk.....	Square Yard
701.1	Cement Concrete Sidewalk Driveways	Square Yard
701.2	Cement Concrete Pedestrian Curb Ramp	Square Yard

GUIDE TO THE INTERIM SUBSECTION 701 CEMENT CONCRETE SIDEWALK SPECIFICATION

MATERIALS ACTIVITIES

Section	Activity	
701.30.A	Combined Aggregate System	
701.30.A.1	The mix design's combined aggregate system should meet Table 701.30-1: Tarantula Curve Particle Size Distribution.	Recommendation
701.30.A.2	The mix design's combined aggregate system should meet Table 701.30-2 / Figure 701.30-1: Shilstone Workability-Coarseness.	Recommendation
701.30.A.3	The mix design's combined aggregate system should be analyzed using the Fineness Modulus.	Recommendation
701.30.A.4	The mix design's combined aggregate system should be analyzed using the Coarse Aggregate Content.	Recommendation
701.30.B	Paste System	
701.30.B.1	The mix design's Water-Cementitious Ratio should be ≤ 0.40 (Table 701.30-3: Freezing, Thawing, and De-icing Resistance).	Recommendation
701.30.B.1	The mix design's Water-Cementitious Ratio shall be ≤ 0.45 (Table 701.30-3: Freezing, Thawing, and De-icing Resistance).	Required
701.30.B.2	The mix design's Air Content should approach the recommended Air Content Targets identified in Table 701.30-4: Freezing, Thawing, and De-icing Resistance.	Recommendation
701.30.B.3	The mix design's Cement and Supplementary Cementitious Materials (SCM) Content shall meet Table 701.30-5: Alkali Silica Reaction and Freezing, Thawing, and De-icing Resistance requirements.	Requirement
701.30.B.3	Test results meeting Table 701.30-6: Alternative Performance Evaluation to Alkali Silica Reaction Resistance requirements may be used in lieu of the mix design requirements identified in Table 701.30-5: Alkali Silica Reaction and Freezing, Thawing, and De-icing Resistance requirements.	Optional
701.30.B.4	The mix design should incorporate Chemical Admixtures identified in Table 701.30-7: Chemical Admixtures to enhance the properties of the concrete.	Recommendation
701.30.B.5	The mix design's Paste Content should approach the recommended targets identified in Table 701.30-8: Paste Content.	Recommendation

701.73	Acceptance Sampling and Testing	
T 119	The Slump shall meet Table 701.71-1: Minimum Acceptance Sampling and Testing Requirements (± 1.5 from Slump Target identified by the Concrete Producer on the Batch Ticket).	Requirement
T 119	The Segregation Resistance shall meet Table 701.71-1: Minimum Acceptance Sampling and Testing Requirements.	Requirement
T 309	The Concrete Temperature shall meet Table 701.71-1: Minimum Acceptance Sampling and Testing Requirements.	Requirement
T 22	The Compressive Strength (7, 28, and 56 days) shall meet Table 701.71-1: Minimum Acceptance Sampling and Testing Requirements.	Requirement
T 121 T 152 T 196	The Air Content shall meet Table 701.71-1: Minimum Acceptance Sampling and Testing Requirements (5.5 – 8.5%).	Requirement
T 303 or C1567	The resistance to Alkali Silica Reaction shall meet Table 701.71-1: Minimum Acceptance Sampling and Testing Requirements (One per year for mix design verification).	Requirement

CONTRACTOR ACTIVITIES

Section	Activity	
701.40	Pre-Placement	
	The Contractor should have a minimum of two (2) Operators.	Recommendation
	The Contractor shall apply sufficient base compaction.	Requirement
	The Contractor shall moisten sub-base, free of standing water.	Requirement
	The Contractor shall secure forms, straight and level.	Requirement
	The Contractor shall mark expansion locations.	Requirement
	The Contractor shall be prohibited from performing the following practices: Placement on frozen sub-grade.	Requirement
701.41	Placement (Concrete Discharging)	
	The Contractor should have a minimum of two (2) Operators.	Recommendation
	The Contractor shall direct concrete trucks.	Requirement
	The Contractor shall handle chute discharge and truck movement.	Requirement
	The Contractor shall assist in preparing concrete for testing.	Requirement
	The Contractor shall direct trucks to washout area.	Requirement
	The Contractor shall provide general help.	Requirement

	The Contractor / Concrete Producer shall be prohibited from performing the following practices: Adding constituent materials not in conformance with AASHTO M 157 or without Department consent.	Requirement
701.41	Placement	
	The Contractor should have a minimum of two (2) Operators.	Recommendation
	The Contractor shall localize placement to minimize moving material.	Requirement
	The Contractor shall level concrete in front of the screed.	Requirement
	The Contractor shall operate come-alongs or flat headed shovel to move concrete in form.	Requirement
	The Contractor shall consolidate concrete along form edge to avoid honeycombing.	Requirement
	The Contractor shall operate screed over top of forms in sawing action for surface leveling.	Requirement
	The Contractor shall operate magnesium bull float to push coarse aggregate below the surface and fill in the low spots or depressions.	Requirement
	The Contractor shall be prohibited from performing the following practices: Toothed raking, dragging of internal vibrator, and internal vibrator to move concrete; steel troweling or floating.	Requirement
701.42	Initial Curing (When Applicable)	
	The Contractor should have a minimum of one (1) Operator.	Recommendation
	The Contractor shall apply 701.30.C.1: Liquid-Applied Evaporation Reducers when applicable.	Required when applicable
701.43	Finishing	
	The Contractor should have a minimum of two (2) Operators.	Recommendation
	The Contractor shall permit bleed water to dissipate and concrete to set.	Requirement
	The Contractor shall operate a hose drag or squeegee to remove water from the surface.	Requirement
	The Contractor shall check surface for flatness, fill/cut as necessary.	Requirement
	The Contractor shall finish surface with magnesium float.	Requirement
	The Contractor shall apply pulled broom finish at proper time to acceptable texture.	Requirement
	The Contractor shall clean broom when excessive mortar adheres.	Requirement
	The Contractor shall remove excess water from broom before use.	Requirement

	The Contractor shall finish edges and joints.	Requirement
	The Contractor shall finish well formed, properly spaced joints to sufficient depth.	Requirement
	The Contractor shall be prohibited from performing the following practices: Steel troweling or floating; adding water to the surface; excessive working of surface; pushing broom across surface.	Requirement
701.44	Intermediate Curing (When Applicable, Apply One of the Methods)	
	The Contractor should have a minimum of one (1) Operator.	Recommendation
	The Contractor shall apply 701.30.C.1: Liquid-Applied Evaporation Reducers when applicable and if selected.	Required when applicable
	The Contractor shall apply 701.30.E.3.a: Liquid Membrane-Forming Compounds when applicable and if selected.	Required when applicable
	The Contractor shall apply 701.30.E.3.b: Liquid Membrane-Forming Compounds for Curing and Sealing when applicable and if selected.	Required when applicable
701.45	Final Curing (Apply One of the Methods)	
	The Contractor should meet the minimum number of operators identified in Table 701.62-2: Minimum Operator Activities.	Recommendation
	The Contractor shall apply 701.30.E.1: Saturated Covers if selected.	Requirement
	The Contractor shall apply 701.30.E.2: Sheet Materials if selected.	Requirement
	The Contractor shall apply 701.30.E.3.a: Liquid Membrane-Forming Compounds if selected.	Requirement
	The Contractor shall apply 701.30.E.3.b: Liquid Membrane-Forming Compounds for Curing and Sealing if selected.	Requirement
701.46	Protective Sealing (If Required)	
	The Contractor should have a minimum of one (1) Operator.	Recommendation
	The Contractor shall apply 701.30.F: Protective Sealing Compounds at least 28 days after placement. Application of 701.30.F: Protective Sealing Compounds is NOT REQUIRED IF 701.30.E.3.b: Liquid Membrane-Forming Compounds for Curing and Sealing was applied.	Required if 701.30.E.3.b Curing and Sealing Compound was Not Applied
701.47	Cold Weather Concreting (When Applicable)	
	The Contractor should have a minimum of four (4) Operators.	Recommendation
	The Contractor shall submit a Cold Weather Concreting Plan meeting 701.47.	Required when applicable

	The Contractor shall apply cold weather concreting materials and procedures meeting 701.47 and the Department approved Contractor cold weather concreting plan.	Required when applicable
701.48	Hot Weather Concreting (When Applicable)	
	The Contractor should have a minimum of four (4) Operators.	Recommendation
	The Contractor shall submit a Hot Weather Concreting Plan meeting 701.48.	Required when applicable
	The Contractor shall apply hot weather concreting materials and procedures meeting 701.47 and the Department approved Contractor hot weather concreting plan.	Required when applicable
701.61	Contractor Quality Control Plan	
	The Contractor shall prepare and submit a Quality Control Plan (QC Plan) to the Department for review.	Requirement
701.62	Production Personnel	
701.62.A	Foreman	
	The Contractor shall have a minimum of One (1) Foreman.	Requirement
	A Foreman shall be present throughout the entire duration of the construction operation with at least one of the following personnel certifications. <ul style="list-style-type: none"> • NRMCA Concrete Exterior Finisher Certification • ACI Concrete Flatwork Technician and Flatwork Finisher 	Requirement
	The Contractor's Foreman shall review and compare batch ticket quantities and sources to approved mix design.	Requirement
	The Contractor's Foreman shall monitor conformance to AASHTO M 157 Standard Specification for Ready-Mixed Concrete.	Requirement
	The Contractor's Foreman shall monitor conformance to Department specifications.	Requirement
	The Contractor's Foreman shall monitor Production Personnel activities.	Requirement
	The Contractor's Foreman shall verify that proper equipment is on hand prior to start of construction.	Requirement
	The Contractor's Foreman shall monitors equipment, environmental conditions, materials, and workmanship.	Requirement
	The Contractor's Foreman shall prohibit the use of prohibited equipment and practices.	Requirement
	The Contractor's Foreman shall acknowledge sampling, testing, and inspection results.	Requirement

701.62.B	Operators	
	Concrete sidewalk shall be constructed by sufficiently staffed, trained, experienced, and qualified equipment operators and craftsmen, who are presently involved in sidewalk construction, throughout the entire duration of the construction operation, per the requirements specified in Sections 701.40 to 701.48.	Requirement
701.63	Quality Control Inspection	
	<p>Quality Control inspection shall be performed and reported on inspection report forms by qualified Quality Control Technicians, to confirm conformance to specifications and to visually inspect equipment, environmental conditions, materials, and workmanship. Quality Control Technicians shall obtain at least one of the following personnel certifications.</p> <ul style="list-style-type: none"> • NRMCA Concrete Exterior Finisher Certification • ACI Concrete Flatwork Technician and Flatwork Finisher <p>Quality Control inspection report forms shall be completed by the Contractor and submitted to the Department for review</p>	Requirement

Massachusetts Department of Transportation
Quality Assurance Specifications for Superpave Waterproofing Surface Course

DOCUMENT 00714

SUPERPAVE WATERPROOFING SURFACE COURSE

Massachusetts Department of Transportation
 Quality Assurance Specifications for Superpave Waterproofing Surface Course

SUBSECTION 457
SUPERPAVE WATERPROOFING SURFACE COURSE
DESCRIPTION
457.20 General.

The work under this Section consists of producing and placing a SUPERPAVE Waterproofing Surface Course (SSC-W). This Hot Mix Asphalt (HMA) mixture is intended to serve as a waterproof surface course for structures, including bridge decks, tunnels, and other roadway structures. All work associated with SSC-W is subject to the requirements of Section 450 Hot Mix Asphalt Pavement, Section M3 Asphaltic Materials, and the requirements herein.

MATERIALS
457.30 General.

Provide materials as specified in Section 450 Hot Mix Asphalt Pavement and Section M3 Asphalt Materials, as amended herein:

Performance Graded Asphalt Binder	M3.01.0
Warm Mix Asphalt Additive	M3.01.4
Asphalt Release Agents	M3.01.6
Asphalt Emulsion for Tack Coat	M3.03.1
Hot Applied Pavement Joint Adhesive	M3.05.4
Hot Mix Asphalt	M3.06.0
Hot Mix Asphalt Production Facility	M3.12.0
Contractor Quality Control Laboratory	M3.13.1
Department Acceptance Laboratory	M3.13.2

SSC-W Mix Design.

SSC-W shall be a mixture comprised of coarse aggregate, fine aggregate, asphalt binder, and warm mix asphalt additive, and may include mineral filler and crumb rubber. Reclaimed Asphalt Pavement (RAP), Recycled Asphalt Shingles (RAS), Manufactured Asphalt Shingles (MAS), or Recycled Glass Aggregate shall not be used in SSC-W mixtures.

The Contractor shall be responsible for development of an SSC-W Laboratory Trial Mix Formula (LTMF) for each SSC-W mixture type specified for the contract in accordance with the requirements of Subsection 457.30.

(1) Performance Graded Asphalt Binder.

The asphalt binder shall be polymer modified and achieve the performance grade necessary for the SSC-W mixture to meet the performance testing requirements specified below. The Contractor shall coordinate with the asphalt binder Supplier to select the proper binder grade.

The asphalt binder shall be storage-stable, pre-blended, homogeneous, and polymer modified. The asphalt binder shall be storage-stable, pre-blended, homogeneous, and polymer modified using Styrene-Butadiene (SB), Styrene-Butadiene-Styrene (SBS), or Styrene-Butadiene-Rubber (SBR) formulations. Other methods of binder modification must be reviewed by the MassDOT Research & Materials Section prior to the mix design. The asphalt binder certifications shall provide the continuous PG binder grade, the polymer content and the polyphosphoric acid content.

The continuous grading of the asphalt binder used for the mix design shall be reported in the mix design submission.

Massachusetts Department of Transportation
Quality Assurance Specifications for Superpave Waterproofing Surface Course

(2) Aggregate.

Aggregate shall conform to the requirements of Subsection M3.11.2. Fine aggregate shall be a manufactured sand and have an uncompacted void content of at least 45 percent when tested according to AASHTO T 304, Method A. The minimum sand equivalent of the fine aggregate shall be 45 percent when tested according to AASHTO T 176.

(3) LTMF Design and Verification.

The Contractor shall develop and submit a Laboratory Trial Mix Formula (LTMF), which is to be proposed as a Job Mix Formula, a minimum of sixty (60) days prior to the start of SSC-W production in accordance with the requirements of Subsection 457.30 and MassDOT's Asphalt Mix Design approval process. The submission shall identify the source of each component and provide results confirming that materials meet the criteria specified in Table 457.30-1 and Table 457.30-2.

The Contractor shall not proceed to SSC-W production for the Control Strip as outlined below until the LTMF is verified by the Department.

The Contractor shall submit the LTMF with supporting documentation to the Department along with samples of aggregate material and PG asphalt binder. An adequate amount of the aggregate and PG asphalt binder shall be supplied in order to verify the LTMF. The Department will use these samples for verification the LTMF and to benchmark the binder and mix design performance. Benchmarking shall include determining the continuous grade of the binder.

Should a change in sources, including the PG asphalt binder, be made or a change in the properties of materials occurs, the Department will require that a new LTMF be developed and approved before production can continue.

Massachusetts Department of Transportation
Quality Assurance Specifications for Superpave Waterproofing Surface Course

Table 457.30-1 –Aggregate Gradation and Percent Binder Requirements for SSC-W

Sieve Size	9.5 mm Mixture Design Control Points (% Passing) ⁽²⁾		12.5 mm Mixture Design Control Points (% Passing) ⁽²⁾	
	Min	Max	Min	Max
¾"	100	-	100	-
½"	100	-	90	100
3/8"	80	100	70	90
#4	55	85	45	75
#8	32	42	28	38
#16	20	30	20	30
#30	12	22	12	22
#50	7	16	7	16
#100	3	12	3	12
#200	2.0	6.0	2.0	6.0
N _{des} , gyrations	50		50	
P _b , %	≥ 7.0		≥ 7.0	
VCA _{mix} , % ⁽¹⁾	< VCA _{DRC}		< VCA _{DRC}	
Draindown, % ⁽³⁾	≤ 0.1		≤ 0.1	

⁽¹⁾ VCA determination shall be performed in accordance with the procedure outlined by MassDOT Research & Materials.
⁽²⁾ The SSC-W mix design gradation may go outside of the Mixture Design Control Points with prior approval of the Engineer. The mix design will still be required to meet the volumetric and performance criteria.
⁽³⁾ Draindown shall be tested in accordance with AASHTO T 305 at the production temperature.

Table 457.30-2 – Volumetric Requirements for Design and Control of SSC-W

	Required Density at N _{des}	Voids Filled with Asphalt	Voids in Mineral Aggregate (%)	Dust to Binder Ratio
	(% of G _{mm})	(VFA)	(VMA)	
Design Requirements	99	90 - 100	≥ 18.0 (SSC-W-9.5 mm)	0.3 - 0.9
Control Requirements	98 - 100		≥ 17.0 (SSC-W-12.5 mm)	

The Engineer may require that the Contractor demonstrate that the mixture meets a minimum tensile strength ratio (TSR) of 90 percent when tested according to AASHTO T 283 with the following modifications:

1. Compact specimens to 40 gyrations according to AASHTO T 312.
2. If less than 55 percent saturation is achieved, the procedure does not need to be repeated, unless the difference in tensile strength between duplicate specimens is greater than 25 pounds per square inch.

Massachusetts Department of Transportation
 Quality Assurance Specifications for Superpave Waterproofing Surface Course

(4) LTMF Performance Testing.

Submit to the Department a sample comprised of six (6) gyratory specimens, three (3) 5-gallon metal buckets of loose SSC-W mixture, and a sufficient amount of raw material for performance testing of the LTMF by the Department.

The 6 gyratory specimens shall be compacted according to AASHTO T 312 to a height of 60 mm and shall have an air void content of 3.0 ± 0.5 percent. The Department reserves the right to be present at the time of molding the gyratory specimens. The specimens will be tested using a Hamburg Wheel Tracking Device (HWTd) according to AASHTO T 324 at 45°C.

The Department will use the supplied loose mix sample to compact four (4) beam specimens to an air void content of 1.5 ± 0.5 percent for Flexural Beam Fatigue testing. The Beam Fatigue specimens will be tested according to AASHTO T 321 at 15°C, 10 Hz loading frequency, and 1,500 micro-strains.

The Department will approve the LTMF if the performance testing requirements in Table 457.30-3 are met. If the LTMF does not meet the HWTd and Flexural Beam Fatigue criteria, the LTMF shall be rejected.

Table 457.30-3 – Performance Testing Requirements for SSC-W

Performance Characteristic	Test Method	Requirement
HWTd Maximum Rut Depth	AASHTO T 324 @ 45°C ⁽¹⁾	< 0.25 inch
Beam Fatigue Test Failure	AASHTO T 321 @ 15°C ⁽²⁾	> 100,000 cycles
⁽¹⁾ Maximum rut depth after 20,000 passes. ⁽²⁾ Test performed at a strain level of 1,500 microstrains.		

CONSTRUCTION PROCEDURES

457.40 General.

Construction procedures for the SSC-W mixture shall be in accordance with Section 450, as amended herein.

457.41 Weather Limitations.

When SSC-W is to be paved on a concrete bridge deck, the deck’s surface moisture content shall be measured in accordance with ASTM F2659 and shall be less than 5.0%. Do not place SSC-W mixture if it is precipitating. Do not allow trucks to leave the plant when precipitation is imminent. If precipitation occurs the Contractor may resume operations when precipitation has stopped and when the concrete surface has a moisture content less than 5.0%. Do not pave if the base temperature is below 50°F.

457.42 Tack Coat.

A tack coat of asphalt emulsion shall be applied in accordance with Subsection 450.43G. Ensure that required repairs to the underlying structure have been completed before placing the tack coat and SSC-W mixture. Clean the surface where the SSC-W mixture is to be placed of foreign and loose material.

Massachusetts Department of Transportation
Quality Assurance Specifications for Superpave Waterproofing Surface Course

Immediately before beginning paving operations, ensure that the surface is completely dry. Use heaters, propane torches or other appropriate methods acceptable to the Department to dry the surface.

Only apply tack coat that can be paved over in the same day. Apply tack coat at an emulsion application rate of 0.07 gallons per square yard. Adjust the application rate to produce a uniform coating, with no excess material. Ensure that the tack coat has fully broken prior to placing the SSC-W mixture.

457.43 Joint Adhesive.

A hot applied pavement joint adhesive meeting the requirements in Subsection 457.30 shall be applied to all joint edges and vertical surfaces. Apply a 1/8-inch thick, uniform coating of joint adhesive to vertical contact surfaces of curbing, gutters, scuppers, parapets and other structures before placing the SSC-W against them. The joint adhesive shall be applied in a manner that ensures an even coating thickness.

457.44 SSC-W Placement.

Procedures for placement of the SSC-W mixture shall be in accordance with Subsection 450.47. Place SSC-W mixture at the laydown temperature recommended by the supplier of the asphalt binder.

457.45 SSC-W Compaction.

Compact the SSC-W mixture as specified in Subsection 450.48. Operate rollers in static mode only. Rollers operated in oscillatory mode may be permitted provided that mixture does not excessively bleed or flush. The compacted SSC-W pavement course shall be free of the mat deficiencies depicted in Subsection 450.48D and shall meet the requirements for in-place density, thickness, and ride quality specified in Subsection 457.65.

457.46 SSC-W Joints.

Construct all joints in accordance with Subsection 450.49. The use of wedge joints will not be permitted. Where traffic operations allow, adjacent passes shall be paved prior to the previous pass achieves a mat temperature below 200°F. The Contractor will measure the surface smoothness and test the in-place density of each transverse joint and longitudinal joint as specified in Subsection 457.65.

457.47 Opening to Traffic.

No vehicular traffic or loads shall be permitted on the newly completed SSC-W pavement until adequate stability has been attained and the material has cooled sufficiently to a surface temperature of 120°F or less as indicated by an infrared thermometer. Remove loose material from the traveled way, shoulder, and auxiliary lanes before opening to traffic.

457.48 Control Strip Requirements.

SSC-W Control Strip.

A minimum of thirty (30) days prior to the start of SSC-W production the Contractor shall produce and place a Control Strip Lot for the SSC-W mixture at a location off of the project site, agreed upon by the Department, before proceeding to the first day of production. The Control Strip Lot shall consist of a minimum of 50 tons of SSC-W mixture but the Department will compensate the Contractor for a maximum of 60 tons of SSC-W mixture. The Control Strip will be used to verify that the SSC-W mixture can be produced per the LTMF, to establish rolling patterns, and to verify that the equipment and processes for lay-down are capable of providing the SSC-W pavement course in conformance with these specifications.

Massachusetts Department of Transportation
Quality Assurance Specifications for Superpave Waterproofing Surface Course

(1) Control Strip Inspection.

The Contractor's QC personnel shall perform inspection of each Control Strip Sublot at both the HMA production facility and at the site of SSC-W field placement. The specific attributes to be inspected for the Control Strip shall include the four primary inspection components (Equipment, Environmental Conditions, Materials, Workmanship) in accordance with the requirements of Table 450.64-3, Table 450.64-4 and as specified in the Contractor's approved QC Plan.

The Department will also inspect each Control Strip Sublot for the inspection components of Materials and Workmanship.

(2) Control Strip Sampling and Testing.

The Contractor and the Department shall independently sample and test the Control Strip Lot for the Quality Characteristics identified in Table 457.48-1. The Contractor shall obtain a minimum of two (2) samples of SSC-W mixture for QC testing. The Department will obtain a minimum of one sample of SSC-W mixture for Acceptance testing. The Contractor QC samples and the Agency Acceptance sample(s) shall be randomly obtained from the Lot in accordance with ASTM D3665 and the prescribed sampling protocols for each Quality Characteristic as outlined in Table 457.65-1. Split samples shall be retained for each sample by both the Contractor and the Department in accordance with Subsection 450.65D.

The Contractor and the Department shall each obtain three (3) cores from randomly selected locations in the Control Strip to test the bulk specific gravity of the SSC-W mixture. The Contractor shall fill all core holes, whether from QC sampling or Department Acceptance sampling, with fresh SSC-W mixture from the same Lot. The filled core holes shall be thoroughly compacted as outlined in the Contractor's approved QC Plan. The Contractor and Department shall compare the density gauge readings and the core test results to establish a correlation. Both the Contractor and the Department will use this correlation as a guide for their respective density gauge testing for Quality Control and Acceptance during SSC-W production and placement.

(3) Control Strip Performance Testing.

The Department will obtain a sample comprised of five (5) 5-gallon metal buckets of loose SSC-W mixture from the Control Strip Lot for performance testing. Test specimens will be prepared and tested in accordance with AASHTO T 324 and AASHTO T 321 as specified in Section 457.30A(4).

(4) Evaluation of Control Strip Inspection Data.

The Contractor and the Department shall each evaluate their respective Control Strip inspection data against the requirements for Materials and Workmanship specified in Subsection 450.43 through Subsection 450.52 as well as Subsection 457.42 through Subsection 457.48.

(5) Evaluation of Control Strip Sampling and Testing Data.

The Contractor and the Department shall each evaluate their respective Control Strip test results against the Control Strip Quality Limits in Table 457.48-1.

(6) Evaluation of Control Strip Performance Testing Data.

The Department will evaluate the Control Strip sample performance testing results against the requirements in Table 457.30-3.

(7) Verification of Control Strip Lot and LTMF.

In order for a Control Strip Lot and corresponding LTMF to be Verified, the criteria in Table 457.48-1 and Subsection 450.51 must be met. In addition, the performance testing results shall meet the requirements in Table 457.30-3.

Massachusetts Department of Transportation
Quality Assurance Specifications for Superpave Waterproofing Surface Course

(8) Acceptance and Payment of Control Strips.

If the Control Strip Lot has been Verified in accordance with the requirements above, the Lot will be accepted and paid for at the unit bid price per ton of SSC-W mixture. If the Control Strip Lot is not Verified, the Contractor will be required to construct another Control Strip.

Table 457.48-1 SSC-W Control Strip Quality Limits

Quality Characteristic	Target	Specification Limits		Engineering Limits		Acceptance Limit
		LSL	USL	LEL	UEL	
PG Asphalt Binder Grading	Per Binder Grade specified	N/A	N/A	Per AASHTO M320	Per AASHTO M320	N/A
PG Asphalt Binder Content	Per LTMF	Target - 0.3 %	Target + 0.3 %	Target - 0.4 %	Target + 0.4 %	N/A
Particle Coating	100%	98 %	N/A	95%	100%	
Volumetrics: Air Voids	1%	0 %	2 %	0 %	3 %	N/A
Fines to Effective Asphalt Ratio	Per JMF	N/A	N/A	0.3	0.9	N/A
Moisture Content of SSC-W Mixture	Per JMF	N/A	N/A	0%	1%	N/A
Combined Gradation: Passing #4 and Larger Sieves	Per JMF	N/A	N/A	Target - 6%	Target + 6%	N/A
Combined Gradation: Passing #8 Sieve	Per JMF	N/A	N/A	Target - 5%	Target + 5%	N/A
Combined Gradation: Passing #16 to #50 Sieve	Per JMF	N/A	N/A	Target - 3%	Target + 3%	N/A
Combined Gradation: Passing #100 Sieve	Per JMF	N/A	N/A	Target - 2%	Target + 2%	N/A
Combined Gradation: Passing #200 Sieve	Per JMF	N/A	N/A	Target - 1.5%	Target + 1.5%	N/A
In-Place SSC-W Mat Density (Density Gauge)	99% of G _{mm}	97% of G _{mm}	N/A	96% of G _{mm}	100% of G _{mm}	N/A
Transverse Joint Density (Density Gauge)	95% of G _{mm}	N/A	N/A	92% of G _{mm}	100% of G _{mm}	N/A
Longitudinal Joint Density (Density Gauge)	95% of G _{mm}	N/A	N/A	92% of G _{mm}	100% of G _{mm}	N/A

Massachusetts Department of Transportation
Quality Assurance Specifications for Superpave Waterproofing Surface Course

CONTRACTOR QUALITY CONTROL

457.60 General.

The Contractor shall provide a Quality Control (QC) system in accordance with the provisions of Section 450 Hot Mix Asphalt, as modified below.

457.61 Contractor Quality Control Plan.

The QC system shall be detailed in a Quality Control Plan (QC Plan). This may be either a standalone QC Plan for the SSC-W mixture, or if a QC Plan is required for other HMA mixtures on the project, the SSC-W mixture may be addressed in that QC Plan. The QC Plan shall conform to the requirements in Subsection 450.61 for submittal, format, contents, and approval.

457.62 Quality Control Personnel Requirements.

The Contractor shall provide the QC personnel required by Subsection 450.62.

457.63 Quality Control Laboratory Facility Requirements.

The Contractor shall provide the QC laboratory facilities required by Subsection 457.40.

457.64 Quality Control Inspection.

The Contractor shall perform Quality Control inspection of the SSC-W mixture in accordance with the requirements of Subsection 450.64, as amended herein.

A. QC Inspection for Preparation of Underlying Surface.

If HMA patching is required on the approach pavement, Quality Control inspection of HMA for Patching shall be performed in accordance with the requirements of Subsection 450.64A and Table 450.64-1. Quality Control inspection of the tack coat for HMA mixtures shall be performed in accordance with the requirements of Table 450.64-2.

B. QC Inspection for Production & Placement of SSC-W Lots.

The Contractor's QC personnel will perform Quality Control inspection at both the HMA production facility and at the site of SSC-W field placement to ensure that the production and placement processes are providing work conforming to the contract requirements. For purposes of QC inspection, the total quantity of SSC-W produced and placed during the same construction season will constitute a Lot. Each in-place Lot shall be divided into 100 lane-feet Sublots. The specific attributes to be inspected for each SSC-W Lot shall be in accordance with the requirements of Subsection 450.43 through Subsection 450.52, as amended herein, and as outlined in Table 450.64-3 and Table 450.64-4.

457.65 Quality Control Sampling and Testing Requirements.

The Contractor shall perform Quality Control sampling and testing of the SSC-W mixture in accordance with the requirements of Subsection 450.65, as amended herein.

Massachusetts Department of Transportation
 Quality Assurance Specifications for Superpave Waterproofing Surface Course
A. Quality Control Testing of Prepared Underlying Surface.

Quality Control sampling and testing of HMA for Patching shall be performed in accordance with the requirements of Table 450.65-1.

B. Quality Control Testing of SSC-W Lots.

The Contractor's QC personnel will perform Quality Control sampling and testing at both the SSC-W production facility and at the site of HP field placement to ensure that the production and placement processes are providing work conforming to the contract requirements. All QC sampling and testing shall be in accordance with the AASHTO, ASTM, NETTCP, or Department procedures specified in Table 457.65-1 below. The Contractor shall furnish approved containers for all material samples. The Department shall be provided the opportunity to monitor and witness all QC sampling and testing.

Quality Control testing of the SSC-W pavement course for Ride Quality will only be required when the criteria in Subsection 450.65F(11) are met.

Table 457.65-1 - Minimum Quality Control Sampling & Testing of SSC-W Lots

Quality Characteristic	Test Method(s)	Sublot Size	Minimum Test Frequency	Point of Sampling	Sampling Method
PG Asphalt Binder Grading	Per Binder Grade from JMF	Per Supplier QC Plan or 24,000 tons of SSC-W per Subsection 450.65F ⁽¹⁾	See Subsection 450.65F(1)	See Subsection 450.65F(1)	Random AASHTO R 66
Aggregate Gradation	AASHTO T 27	Per QC Plan	Per QC Plan	At HMA Plant Per QC Plan	Random AASHTO T 2
PG Asphalt Binder Content	AASHTO T 308	150 tons	1 per Sublot ⁽¹⁾	From Haul Vehicle at Plant	Random AASHTO T 168 and R 47
Combined Aggregate Gradation	AASHTO T 30	150 tons	1 per Sublot ⁽¹⁾	From Haul Vehicle at Plant	Random AASHTO T 168 and R 47
Particle Coating	AASHTO T 195 ⁽²⁾	150 tons	1 per Sublot ⁽¹⁾	From Haul Vehicle at Plant	Random AASHTO T 168 and R 47
Maximum Theo. Specific Gravity	AASHTO T 209	150 tons	1 per Sublot ⁽¹⁾	From Haul Vehicle at Plant	Random AASHTO T 168 and R 47
Bulk Specific Gravity	AASHTO T 166 (Method A)	150 tons	1 per Sublot ⁽¹⁾	From Haul Vehicle at Plant	Random AASHTO T 168 and R 47
Volumetrics: Air Voids, VMA, VFA	AASHTO T 312 and R 35	150 tons	1 per Sublot ⁽¹⁾	From Haul Vehicle at Plant	Random AASHTO T 168 and R 47
Fines to Effective Asphalt Ratio	AASHTO T 312 and R 35	150 tons	1 per Sublot ⁽¹⁾	From Haul Vehicle at Plant	Random AASHTO T 168 and R 47
Moisture Content of SSC-W Mixture	AASHTO T 329 ⁽³⁾	150 tons	1 per Sublot ⁽¹⁾	From Haul Vehicle at Plant	Random AASHTO T 168 and R 47

Massachusetts Department of Transportation
 Quality Assurance Specifications for Superpave Waterproofing Surface Course

Quality Characteristic	Test Method(s)	Sublot Size	Minimum Test Frequency	Point of Sampling	Sampling Method
In-place SSC-W Mat Density (Density Gauge)	AASHTO T 343 or T 355	150 tons	3 per Sublot ⁽¹⁾	From Compacted SSC-W Course	Selective & Random AASHTO T 343 or T 355
Transverse Joint Density (Density Gauge)	AASHTO T 343 or T 355	Each Joint	3 per Sublot ⁽¹⁾	At Finished Joint	Selective & Random AASHTO T 343 or T 355
Longitudinal Joint Density (Density Gauge)	AASHTO T 343 or T 355	50 feet per Joint	3 per Sublot ⁽¹⁾	At Finished Joint	Selective & Random AASHTO T 343 or T 355
Ride Quality (IRI)	AASHTO R 54 Per Subsection 450.65F(11)	0.1 miles per each Wheel Path	3 Runs per Sublot	Each Pavement Course Per Subsection 450.65F(11)	Random Per Subsection 450.65F(11)
⁽¹⁾ In the event that the total daily SSC-W production is less than one Sublot, a minimum of one random QC sample shall be obtained for the day's production. On bridge decks over 1,500 ft ² a minimum of 3 tests shall be performed. ⁽²⁾ At least 95 percent of the coarse aggregate particles shall be entirely coated with asphalt binder as determined according to AASHTO T 195. ⁽³⁾ The moisture content of the mixture from the plant shall not exceed 1.0 percent.					

457.66 Quality Control Documentation and Data Evaluation.

The Contractor shall document all QC inspection, sampling and testing and perform evaluation of QC data in accordance with Subsection 450.66.

457.67 Corrective Action.

As part of the Quality Control system, the Contractor shall implement corrective action in accordance with Subsection 450.67 for any part of a Lot that is determined by inspection or testing to not be in conformance with the quality requirements.

457.68 Quality Control Records System.

The Contractor shall maintain a QC records system for the SSC-W in accordance with Subsection 450.68.

Massachusetts Department of Transportation
Quality Assurance Specifications for Superpave Waterproofing Surface Course

DEPARTMENT ACCEPTANCE

457.70: General

The Department is responsible for performing all Acceptance activities and making the final Acceptance determination for each SSC-W Lot produced and placed. The Department's Acceptance System will include monitoring the Contractor's QC activity and performing Acceptance inspection, sampling and testing in order to determine the Quality and corresponding payment for each Lot.

457.71 Acceptance System Approach.

The Department's Acceptance determination for each Lot of SSC-W will be based on an evaluation of its Acceptance inspection information, testing data, and performance testing results.

457.72 Department Monitoring of Contractor Quality Control.

The Department will monitor the Contractor's Quality Control system in accordance with Section 450.72.

457.73 Acceptance Inspection.

The Department will perform Acceptance inspection of all work items addressed under Section 450 Hot Mix Asphalt Pavement and herein in accordance with Subsection 450.73, to ensure that all materials and completed work are in conformance with the contract requirements.

A. Acceptance Inspection of Prepared Underlying Surface.

If HMA patching is required on the approach pavement, Acceptance inspection of HMA for Patching shall be performed in accordance with the requirements of Subsection 450.73 and Table 450.73.-1.

Acceptance inspection of the tack coat for HMA mixtures shall be performed in accordance with the requirements of Table 450.73-2.

B. Acceptance Inspection of SSC-W Lots.

The Department will perform Acceptance inspection of the SSC-W at both the HMA production facility and at the site of SSC-W field placement. For purposes of Acceptance inspection, the total quantity of SSC-W mixture produced and placed during the same construction season will constitute a Lot. Each in-place SSC-W Lot will be divided into 100 lane-feet Sublots. The attributes to be inspected and minimum frequency of inspection will be in accordance with the requirements of Subsection 450.73.

457.74 Acceptance Sampling & Testing.

The Department will perform sampling and testing of the SSC-W mixture in accordance with the requirements of Subsection 450.74, as amended herein.

The Department will obtain random samples for Acceptance testing from all Sublots from the SSC-W production facility and at the site of SSC-W field placement in accordance with Subsection 450.74A. The specific Quality Characteristics subject to Department Acceptance testing are identified in Table 457.74-1. All Acceptance testing of SSC-W Lots will be performed by the Department in accordance with the AASHTO, ASTM, NETTCP, or Department test methods specified in Subsection 450.74F and Table 457.74-1.

Massachusetts Department of Transportation
 Quality Assurance Specifications for Superpave Waterproofing Surface Course

Acceptance testing of the SSC-W pavement course for Ride Quality will only be required when the criteria in Subsection 450.65F(11) are met.

Table 457.74-1 - Department Acceptance Sampling & Testing of SSC-W Lots

Quality Characteristic	Test Method(s)	Sublot Size	Minimum Test Frequency	Point of Sampling	Sampling Method
PG Asphalt Binder Grading	AASHTO M 320	12,000 tons of SSC-W using same PG Grade	1 per Sublot	From In-line Sample Valve at HMA Plant	Random AASHTO R 66
PG Asphalt Binder Content	AASHTO T 308	150 tons	1 per Sublot	From Haul Vehicle at Plant	Random AASHTO T 168 & R 47
Particle Coating	AASHTO T 195 ⁽¹⁾	150 tons	1 per Sublot	From Haul Vehicle at Plant	Random AASHTO T 168 & R 47
Volumetrics: Air Voids	AASHTO T 312 and R 35	150 tons	1 per Sublot	From Haul Vehicle at Plant	Random AASHTO T 168 & R 47
Fines to Effective Asphalt Ratio	AASHTO T 312 and R 35	150 tons	1 per Sublot	From Haul Vehicle at Plant	Random AASHTO T 168 & R 47
Moisture Content of SSC-W Mixture	AASHTO T 329	300 tons	1 per Sublot	From Haul Vehicle at Plant	Random AASHTO T 168 & R 47
In-place SSC-W Mat Density (Density Gauge)	AASHTO T 343 or T 355	150 tons	1 per Sublot ⁽²⁾	From Compacted SSC-W Course	Selective & Random AASHTO T 343 or T 355
Ride Quality (IRI)	AASHTO R 54 per Subsection 450.65F(11)	0.1 miles per each Wheel Path	3 Runs per Sublot	Each Pavement Course Per Subsection 450.65F(11)	Random Per Subsection 450.65F(11)
⁽¹⁾ At least 95 percent of the coarse aggregate particles shall be entirely coated with asphalt binder as determined according to AASHTO T 195. ⁽²⁾ On bridge decks over 1,500 ft ² a minimum of 3 tests shall be performed.					

Performance Testing for Acceptance.

The Department will obtain random samples for performance testing from the first Sublot and from a minimum of 25% of all Sublots produced and placed thereafter. Each sample will be comprised of five (5) 5-gallon metal buckets of loose SSC-W mixture. Test specimens will be prepared and tested in accordance with AASHTO T 324 and AASHTO T 321. The Department will evaluate the performance testing results against the requirements in Table 457.30-3.

457.75 Split Sample Correlation.

Split Sample Correlation shall be performed when Validated Contractor QC test data is to be included in the acceptance determination in accordance with Subsection 450.75.

Massachusetts Department of Transportation
 Quality Assurance Specifications for Superpave Waterproofing Surface Course
457.76 Lot Acceptance Determination Based on Inspection Results.

The Department's Acceptance inspection results will be used in the final acceptance determination for each SSC-W pavement Lot in accordance with Subsection 450.76.

457.77 Lot Acceptance Determination Based on Testing Data.

The Department's Acceptance testing data will be evaluated for the final acceptance determination for each SSC-W Lot in accordance with Subsection 450.77 and Table 457.77-1 below.

Table 457.77-1 - Quality Limits for Acceptance of SSC-W Lots

Quality Characteristic	Target	Specification Limits		Engineering Limits		Acceptance Limit
		LSL	USL	LEL	UEL	
PG Asphalt Binder Grading	Per Binder Grade specified	N/A	N/A	Per M3.01.0		N/A
PG Asphalt Binder Content	Per JMF	Target - 0.3 %	Target + 0.3 %	Target - 0.4 %	Target + 0.4 %	60 PWL
Particle Coating	98 %	N/A	N/A	95%	100%	N/A
Volumetrics: Air Voids	1 %	0 %	2 %	0 %	3 %	60 PWL
In-Place SSC-W Mat Density (Density Gauge)	99.0 % of G_{mm}	97.0%	N/A	96.0 % of G_{mm}	100 % of G_{mm}	N/A
Ride Quality: Posted Speed Limit ≥ 55 mph ⁽¹⁾	50 in/mile	N/A	70 in/mile	N/A	80 in/mile	60 PWL
Posted Speed Limit ≥ 40 mph, but < 55 mph ⁽¹⁾	70 in/mile	N/A	100 in/mile	N/A	110 in/mile	60 PWL
Ride Quality: Posted Speed Limit < 40 mph	Not subject to Ride Quality Testing					
⁽¹⁾ Projects with posted speed limits that fall into more than one of the Posted Speed Limit ranges above will be divided into multiple Lots and evaluated separately.						

Lot Acceptance Determination Based on Performance Testing.

The Department's Performance testing data for each SSC-W Lot will be evaluated against the requirements in Table 457.30-3. The Department will accept a Lot if the evaluation of all Acceptance testing data for the Lot is in conformance with the Quality Limits specified in Table 457.30-3 and Table 457.77-1 above.

457.78 Quality Level Analysis Procedures.

For each SSC-W Category A or B Lot, the Engineer will determine the Lot Quality Level, for the applicable Quality Characteristics in Table 457.77-1, using the Quality Level Analysis (QLA) procedures outlined in Subsection 450.78.

Massachusetts Department of Transportation
 Quality Assurance Specifications for Superpave Waterproofing Surface Course

For each SSC-W pavement course that is subject to Ride Quality testing per Subsection 450.65F(11), the Department will determine the Quality Level for the Ride Quality of each SSC-W Lot, using the Quality Level Analysis (QLA) procedures outlined in Subsection 450.78.

DISPUTE RESOLUTION

457.80 Procedures for Dispute Resolution.

The Contractor or the Department may dispute any of the test values that are utilized in the Acceptance determination for a given SSC-W Lot in accordance with the procedures contained in Subsection 450.80 through Subsection 450.84.

COMPENSATION

457.90 Method of Measurement.

HMA for Patching (if required), Tack Coat, and Joint Sealer will be measured as specified in Section 450.90.

SSC-W pavement course mixtures will be measured by the ton and shall be the actual pavement course quantity complete, in place, and accepted by the Engineer. The quantity shall be determined only by weight slips that have been properly countersigned by the Engineer at the time of delivery.

457.91 Basis of Payment.

HMA for Patching (if required), Tack Coat, and Joint Sealer will be paid for as specified in Section 450.91.

Each SSC-W pavement course will be paid for at the contract unit price per ton of in-place mixture under the SSC-W Pay Items specified (Pay Items 457.1 through 457.2). Payment shall include sweeping the underlying surface, transportation, delivery, placement (including providing an MTV, when required), and compaction of each SSC-W pavement course in accordance with Subsection 457.40 through 457.48. Mobile lighting for nighttime milling and paving, in accordance with 450.47, Part C, is considered incidental to the cost of each SSC-W pavement course placed.

All sawcutting required for transverse joints or longitudinal joints in accordance with Subsection 457.46 shall also be included in the contract unit price for each SSC-W pavement course. All required sawcutting in the existing pavement in accordance with this specification will be included in the contract unit price for each SSC-W pavement course, except sawcutting pavement for box widening, which will be paid under Item 482.5.

457.92 Pay Adjustment (PA).

Payment adjustments for each SSC-W Lot will be made, for the applicable Quality Characteristic(s) in Table 457.77-1, in accordance with Subsection 450.92.

457.93	Payment Items	Payment Unit
457.1	SUPERPAVE Waterproofing Surface Course - 9.5 (SSC-W - 9.5)	Ton
457.2	SUPERPAVE Waterproofing Surface Course - 12.5 (SSC-W - 12.5)	Ton
451.	HMA for Patching	Ton

Massachusetts Department of Transportation
Quality Assurance Specifications for Superpave Waterproofing Surface Course

452.	Asphalt Emulsion for Tack Coat	Gallon
453.	HMA Joint Adhesive	Foot
999.490	HMA Pay Adjustment – PG Asphalt Binder Content ⁽¹⁾	Dollar
999.491	HMA Pay Adjustment – Volumetrics (Air Voids) ⁽¹⁾	Dollar
999.494	HMA Pay Adjustment – Ride Quality ⁽¹⁾	Dollar

(1) Not a bid item

DOCUMENT 00715



SUPPLEMENTAL SPECIFICATIONS

SEPTEMBER 30, 2024

The 2024 *Standard Specifications for Highways and Bridges* are amended by the following modifications, additions and deletions. These Supplemental Specifications prevail over those published in the Standard Specifications.

The Specifications Committee has issued these Supplemental Specifications for inclusion into each proposal until such time as they are updated or incorporated into the next Standard Specifications.

Contractors are cautioned that these Supplemental Specifications are dated and will change as they are updated.

DIVISION I

GENERAL REQUIREMENTS AND COVENANTS

SECTION 1: DEFINITION OF TERMS

Subsection 1.03: Defined Terms

Under Part of the First Part replace the words Chapter 90 of the General Laws with MGL Chapter 6C, Section 4[b].

SECTION 2: PROPOSAL REQUIREMENTS AND CONDITIONS

Subsection 2.01: Proposal Forms and Plans

Replace the first paragraph under A. Prequalification Prior to Requesting Proposal Forms with the following:

Subject to the requirements of M.G.L. Chapter 81, Section 8B, each prospective Bidder proposing to bid on any work, excepting the construction, reconstruction, repair or alteration of buildings, to be awarded by the Department or by a municipality under the provisions of M.G.L. Chapter 6C, Section 4(b) must be prequalified in accordance with 700 CMR 14.00 Prequalification of contractors and subcontractors, if the amount of the proposal added to the value of the uncompleted work already under contract with the Department will aggregate \$50,000 or more.

Replace the second paragraph under B. Issuance of Proposal Forms and Plans with the following:

For projects to be awarded under the provisions of M.G.L. Chapter 6C, Section 4(b), bidders may obtain plans and specifications from the applicable municipality at the place specified in the Notice to Contractors.

SECTION 4: SCOPE OF WORK

Subsection 4.04: Changed Conditions

Replace the last paragraph with the following.

The provisions of Section 39N of Chapter 30 of the General Laws, as amended, do not apply to construction contracts entered into on behalf of a municipality under the provisions of M.G.L. Chapter 6C, Section 4(b).

Subsection 4.06: Increased or Decreased Contract Quantities

Replace the second paragraph with the following.

Where the actual quantity of a pay item varies by more than 25% above or below the estimated quantity stated in the Contract, an equitable adjustment in the Contract Price for that pay item shall be negotiated upon demand of either party regardless of the cause of the variation in quantity. A demand for an equitable adjustment must be submitted to the other party within 30 days after beginning the work of the affected item that is greater than 25% above the bid quantity or within 30 days after completing the work when the actual quantity is 25% less than the bid quantity.

SECTION 9: MEASUREMENT AND PAYMENT

Subsection 9.03: Payment for Extra Work

Replace paragraph B., (2) with the following.

- (2) Plus 13 percent of direct labor, for the actual costs of Federal Insurance Contribution Act (FICA) including Medicare; Federal Unemployment Tax Act (FUTA); State Unemployment Tax Act (SUTA), which includes Unemployment Insurance, the Workforce Training Fund Program, ~~and~~ Employer Medical Assistance Contribution, and COVID-19 Recovery Assessment; Earned Sick Time (EST) Law (940 CMR 33.00); and Paid Family and Medical Leave (PFML) Act (458 CMR 2.00); or, as an alternative to the above 13 percent, the Contractor may elect to use actual rates for FICA, FUTA, SUTA, EST and PFML provided the actual rates are supported with verifiable documentation and shall be subject to review by MassDOT Audit Operations.

Subsection 9.04: Partial Payments

Replace the last sentence of the first paragraph with the following;

No such estimates or payment shall be required to be made when, in the Engineer's judgment, the work is not proceeding in accordance with the provisions of the Contract, or when in their judgment the total value of the work completed since the last estimate amounts to less than \$5,000.00.

DIVISION II

CONSTRUCTION DETAILS

DIVISION II: Construction Details

Replace M4.02.15 Cement Mortar with M4.04.0 Grout, Mortar, and Concrete Products where encountered, including in Subsections 230.40, 485.40, 501.40, 685.40, 940.40A and 983.40.

SECTION 100: EARTHWORK, GRADING, DEMOLITION, RODENT CONTROL AND BORINGS

SUBSECTION 150: EMBANKMENT

Subsection 150.62: Embankment Construction with Materials Other Than Rock

Replace the fourth paragraph with the following.

The embankment materials shall be compacted to not less than 95% of the maximum dry density of the embankment material as determined by AASHTO T 99, Method C. If required, a correction for oversized particles shall be in accordance with Annex A of AASHTO T 99. If the material retained on the $\frac{3}{4}$ -in. sieve is 30% or more of the total sample, this test shall not apply and the material shall be compacted to the target density. The target density shall be established by determining the number of passes of a roller required to produce a constant and uniform density, after conducting a series of tests using either AASHTO T 310, *In-Place Density and Moisture Content of Soil and Soil-Aggregate by Nuclear Methods (Shallow Depth)*, AASHTO T 191, *Density of Soil In-Place by the Sand-Cone Method*, or *ASTM D 8167 Standard Test Method for In-Place Bulk Density of Soil and Soil-Aggregate by a Low-Activity Nuclear Method (Shallow Depth)*. The Contractor shall, without additional compensation, employ whatever measures may be necessary to adjust the natural water content of the suitable embankment material to permit the placement and compaction as hereinbefore specified.

SUBSECTION 160: CONTROLLED LOW-STRENGTH MATERIAL

Subsection 160: Controlled Low-Strength Material

Add this new subsection.

DESCRIPTION

160.20: General

Controlled Low-Strength Material shall be installed in accordance with the relevant provisions of Subsection 150: Embankment, Section 901: Cement Concrete and in accordance with the procedures described herein.

Controlled Low Strength Materials (CLSM) shall be a self-compacting, self-leveling, flowable, excavatable or non-excavatable, low strength, rigid setting, and unshrinkable material, used as an alternative to compacted granular fills, including backfill, structural fill, utility fill, pavement base, subgrade, subbase, base course, conduit bedding, erosion control, and void filling.

MATERIALS

160.40: General

Material for controlled low-strength material shall meet the requirement specified of M4.08.0 Controlled Low-Strength Material. The material shall be specified by the Engineer as one of the following types;

- CLSM – Manual Excavatable (≤ 100 psi)
- CLSM – Mechanical Excavatable (101-300 psi)
- CLSM – Structural Non Excavatable (> 300 psi)

Permeability testing as specified in Table M4.08.0-2 shall be required when the material is placed outside of roadway areas or footings for concrete structures, or as directed by the Engineer.

CONSTRUCTION METHODS

160.60: General

The Contractor shall submit a placement plan for Controlled Low-Strength Material (CLSM). The plan shall include the type of CLSM, detailed descriptions of methods used for placing and containing the controlled density fill and the set time to strength.

The Contractor shall remove all debris prior to placing the fill. Fill shall not be placed against any structural elements or utilities unless approved by the Engineer.

CLSM shall be poured in lifts not exceeding 4 feet to insure stability under the fluid effects of the pour. Care shall be taken to ensure the integrity of the forms or other means of supporting the material until the material sets up.

COMPENSATION

160.80: Method of Measurement

Controlled Low-Strength Material shall be measured by the cubic yard in place to the neat lines established on the plans or specified by the Engineer. When backfilling pipes the horizontal neat lines shall be not greater than 3.0 ft. greater than the rated inside diameter of the pipe and vertically from the top of the crushed stone foundation material, if any, or 6 in. below the pipe invert whichever is less to the specified top elevation. A deduction shall be made for the volume of the pipe or conduit encased.

160.81: Basis of Payment

Payment under this item shall constitute full compensation for the placement, testing, and all material, equipment and labor to complete the work.

160.82: Payment Items

- 160.1 Controlled Low-Strength Material - Cubic Yard
Manual Excavatable (≤ 100 PSI)
- 160.2 Controlled Low-Strength Material – Cubic Yard
Mechanical Excavatable (101-300 PSI)
- 160.3 Controlled Low-Strength Material (>300 PSI) Cubic Yard

SECTION 200: DRAINAGE

SUBSECTION 201: BASINS, MANHOLES AND INLETS

Subsection 201.40: General

Replace "Cement Mortar M4.02.15" with "Mortar M4.04.0".

SECTION 400: SUB-BASE, BASE COURSES, SHOULDERS, PAVEMENTS AND BERMS

SUBSECTION 401: GRAVEL SUB-BASE

Subsection 401.60: Gravel Sub-base

Replace the last sentence of the first paragraph with the following.

The specific density of the Gravel Sub-base shall be maintained by determining the number of passes of a roller required to produce a constant and uniform density, after conducting a series of tests using a nuclear device or the sand/volume method in accordance with AASHTO T310, AASHTO T 191, or ASTM D 8167.

SUBSECTION 402: DENSE GRADED CRUSHED STONE FOR SUB-BASE

Subsection 402.61: Spreading and Compacting

Replace the last sentence of the first paragraph with the following.

The specified density of the Dense Graded Crushed Stone shall be maintained by determining the number of passes of a roller are required to produce a constant and uniform density, after conducting a series of tests using a nuclear device or the sand/volume method in accordance with AASHTO T310, AASHTO T 191, or ASTM D 8167.

SUBSECTION 403: RECLAIMED PAVEMENT FOR BASE COURSE AND/OR SUB-BASE

Subsection 403.64: Compaction and Dust Control

Replace the second paragraph with the following.

The reclaimed base course shall be tested for compaction and smoothness and accuracy of grade in accordance with the applicable provisions of 401.60: Gravel Sub-base. The required density shall be measured by using a nuclear device or the sand/volume method in accordance with AASHTO T310, AASHTO T 191, or ASTM D 8167. If any portions are found to be unacceptable by the Engineer, such portions shall be reprocessed, regraded, and recompacted until the required smoothness and accuracy are obtained.

SUBSECTION 404: RECLAIMED PAVEMENT BORROW MATERIAL

Subsection 404.60: General

Replace the second sentence with the following.

The specified density of the Reclaimed Pavement Borrow Material shall be maintained by determining the number of passes of a roller that are required to produce a constant and uniform density, after conducting a series of tests using a nuclear device or the sand/volume method in accordance with AASHTO T310, AASHTO T 191, or ASTM D 8167

SUBSECTION 450: HOT MIX ASPHALT PAVEMENT

Subsection 450.40: General

Add the following paragraph to the end of this subsection.

Prior to placing hot mix asphalt the contractor shall provide notice to the Engineer at least 48 hours in advance of the work. The notice shall include the anticipated schedule, HMA tonnage, the type of mix, the mix provider and plant location.

SUBSECTION 460: HOT MIX ASPHALT PAVEMENT FOR LOCAL ROADS

Subsection 460.40: General

Add the following paragraph to the end of this subsection.

Prior to placing hot mix asphalt the contractor shall provide notice to the Engineer at least 48 hours in advance of the work. The notice shall include the anticipated schedule, HMA tonnage, the type of mix, the mix provider and plant location.

SUBSECTION 466: STRESS ABSORBING MEMBRANE & STRESS ABSORBING MEMBRANE INTERLAYER

Subsection 466.40: General

Replace this subsection with the following.

Prior to placing stress absorbing membrane the contractor shall provide notice to the Engineer at least 48 hours in advance of the work. The notice shall include the anticipated schedule, tonnage, the type of mix, the mix provider and plant location. Stress absorbing membrane and stress absorbing membrane interlayer shall be constructed as specified herein.

SUBSECTION 470: HOT MIX ASPHALT PAVEMENT BERM

Subsection 470.40: General

Replace this subsection with the following.

Prior to placing hot mix asphalt the contractor shall provide notice to the Engineer at least 48 hours in advance of the work. The notice shall include the anticipated schedule, HMA tonnage, the type of mix, the mix provider and plant location. The Contractor shall obtain HMA berm material of the type specified.

SUBSECTION 472: TEMPORARY ASPHALT PATCHING

Subsection 472.40: General

Add the following paragraph to the beginning of this subsection.

Prior to placing hot mix asphalt the contractor shall provide notice to the Engineer at least 48 hours in advance of the work. The notice shall include the anticipated schedule, HMA tonnage, the type of mix, the mix provider and plant location.

SUBSECTION 486: ULTRATHIN BONDED OVERLAY

Subsection 486.40: General

Add the following paragraph to the end of this subsection.

Prior to placing ultrathin bonded overlay the contractor shall provide notice to the Engineer at least 48 hours in advance of the work. The notice shall include the anticipated schedule, tonnage, the type of mix, the mix provider and plant location.

SECTION 600: HIGHWAY GUARD, FENCES AND WALLS

SUBSECTION 690: WALLS REMOVED AND RESET

Subsection 690.40: General

Replace the last sentence with the following.

Mortar shall meet the requirement of M4.04.0: Grout, Mortar, and Concrete Products.

SECTION 700: INCIDENTAL WORK

SUBSECTION 702: HOT MIX ASPHALT SIDEWALKS AND DRIVEWAYS

Subsection 702.40: General

Add the following paragraph to the end of this subsection.

Prior to placing hot mix asphalt the contractor shall provide notice to the Engineer at least 48 hours in advance of the work. The notice shall include the anticipated schedule, HMA tonnage, the type of mix, the mix provider and plant location.

SECTION 800: TRAFFIC CONTROL DEVICES

SUBSECTION 825: RECTANGULAR RAPID FLASHING BEACONS

Subsection 825: Rectangular Rapid Flashing Beacons

Add this new subsection.

DESCRIPTION

825.20: General

This work shall consist of furnishing and installing a solar-powered, actuated, Rectangular Rapid Flashing Beacon (RRFB) system at the location(s) shown in the Plans.

MATERIALS

825.40: General

Rectangular Rapid-Flashing Beacons shall meet the requirements specified in the following Subsections of Division III, Materials:

Cement Concrete.....	M4.02.00
Signal Posts and Bases	M10.05.1
APS Pushbuttons.....	M10.09.1
RRFB Assemblies.....	M10.11.0

An RRFB system shall include the following items (quantities shown in the Major Items List found in the Plans):

- Cement Concrete Foundation
- Signal Post and Pedestal Base
- APS Pushbutton
- Light Bar
- Signage
- Enclosure for Controller, Activation Unit, and Battery System
- Solar Panel
- All mounting and supporting hardware and wiring necessary to complete a working system

The Contractor shall supply cement concrete foundations per the Plans.

The Contractor shall supply Schedule 80 aluminum signal posts with a brushed or spun finish and square, pedestal aluminum bases with a natural finish unless otherwise shown in the Plans or Special Provisions.

Each Light Bar shall have a pair of yellow beacons facing one or both directions of traffic, as shown in the Plans.

All sign designs shall conform to the MUTCD. Sign panel information, including dimensions, shall be per the Plans.

The warning signs (MUTCD code W11-2, W11-15, or S1-1 signs – see Plans for sign type), and the diagonal downward arrow sign (W16-7P) signs shall be on Type A substrate, conforming to 828.42: Panels. The sign sheeting shall be fluorescent yellow-green, conforming to ASTM D4956 Type IX.

An R10-25 sign, conforming to the MUTCD, shall be mounted above the APS Pushbutton on a Type A substrate or may be integral to the button assembly.

The solar panel and battery system may be integrated into a single unit or housed separately, per the manufacturer’s design. These may also be co-housed with the Light Bar and/or the Controller and Activation Unit.

The solar panel and battery system shall be sized appropriately to accommodate 300 actuations per day, 365 days a year, for the duration of the repeating flashing sequence shown in the Plans. The sizing calculations shall be based upon solar and temperature conditions for a typical December-January in Massachusetts. The system shall have a minimum autonomy of 5 days.

Each assembly shall be rated for wind speeds of up to 90 mph.

Any proprietary software required for the programming and/or operation of the system during its lifetime shall be included at no additional cost.

825.41: Shop Drawings

Within 30 days from the Notice to Proceed the Contractor shall submit shop drawings for the RRFB system, including cutsheets for all components to show conformance with M10.05, M10.09.1, and M10.11.0 and these specifications.

Shop drawings shall include all solar and battery sizing calculations. These calculations shall have Contractor- or manufacturer-supplied, site-specific shading factors applied.

825.42: Material Warranties

All RRFB components shall include a minimum 1-year manufacturer's replacement warranty for manufacturing or installation defects starting at the date of acceptance by the Engineer. A battery shall be considered defective should it not retain 80% of its original capacity within the warranty period.

CONSTRUCTION METHODS

825.60: General

RRFBs shall be installed on new foundations at the locations as shown in the Plans. Bases shall be secured to the foundation in accordance with the manufacturer's specifications.

All systems shall be installed per the manufacturer's instructions.

The location and orientation of the system shall be per the Plans.

The arrow on each APS pushbutton shall be aligned parallel to the direction of travel of the crosswalk.

The Light Bar(s) shall be oriented towards the incoming lane(s).

Solar panels shall be oriented to maximize sunlight gain.

SYSTEM OPERATION

825.70: APS Pushbuttons

APS Pushbuttons shall actuate the RRFB system. Upon actuation, an audible speech message shall be broadcast from each pushbutton in the system that says, "Warning lights are flashing," shall be stated twice. This message shall be repeated upon each actuation. No other messages shall be allowed.

While the system is in dark mode, the APS Pushbuttons shall broadcast a locator tone. The locator tone shall have a duration of 0.15 seconds or less and shall repeat at 1-second intervals at all times that the system is in dark mode. The locator tone shall be set 2 to 5 dBA above ambient sound, shall automatically adjust intensity, but cap at a maximum volume of 100 dBA.

APS Pushbuttons shall have all other vibrotactile and percussive indications disabled.

825.71: Light Bar

The Light Bar shall remain dark until actuated.

Upon actuation, all Light Bars in the system shall be activated simultaneously for a predetermined repeating flash sequence. The flashing rate shall be 75 flashing sequences per minute.

The left and right yellow beacons shall operate using the following sequence:

- A. The yellow beacon on the left-hand side shall be illuminated for approximately 50 milliseconds.
- B. Both yellow beacons shall be dark for approximately 50 milliseconds.
- C. The yellow beacon on the right-hand side shall be illuminated for approximately 50 milliseconds.
- D. Both yellow beacons shall be dark for approximately 50 milliseconds.
- E. The yellow beacon on the left-hand side shall be illuminated for approximately 50 milliseconds.
- F. Both yellow beacons shall be dark for approximately 50 milliseconds.
- G. The yellow beacon on the right-hand side shall be illuminated for approximately 50 milliseconds.
- H. Both yellow beacons shall be dark for approximately 50 milliseconds.
- I. Both yellow beacons shall be illuminated for approximately 50 milliseconds.
- J. Both yellow beacons shall be dark for approximately 50 milliseconds.
- K. Both yellow beacons shall be illuminated for approximately 50 milliseconds.
- L. Both yellow beacons shall be dark for approximately 250 milliseconds.

The flash rate of each individual RRFB indication, as applied over the full flashing sequence, shall not be more than 5 flashes per second, to avoid frequencies that might cause seizures.

The sequence shall then be repeated until the duration time has been met and then all yellow beacons shall return to dark mode simultaneously. The duration time shall be per the Plans.

The predetermined repeating flash sequence shall be immediately initiated every time a pushbutton detector is actuated. If the RRFBs are already flashing and an actuation is received, it shall restart the duration time. There shall be no delay time programmed between actuations.

COMPENSATION

825.80: Method of Measurement

RRFBs will be measured as a single system, 2-Post Assembly or 3-Post Assembly, furnished and installed.

825.81: Basis of Payment

The work will be paid for at the contract price each under the respective item for a 2-Post Assembly System or 3-Post Assembly System. Any additional wiring, mounting equipment, or other materials or labor required to for an operating system per the Plans and Specifications shall be considered as incidental to the construction and be included in the contract price.

825.82: Payment Item

825.2	RRFB (2-Post Assembly System)	Each
825.3	RRFB (3-Post Assembly System)	Each

SECTION 900: STRUCTURES

Subsection 922: Elastomeric Bearing Pads

Add this new subsection.

SUBSECTION 922: ELASTOMERIC BEARING PADS

DESCRIPTION

922.20: General

This specification consists of the construction requirements for elastomeric bearing pads. Elastomeric bearing pads shall consist of plain or laminated bearings consisting of layers of elastomers restrained at their interfaces by bonded steel laminates.

MATERIALS

922.40: General

Elastomeric bearing pads shall meet the following requirements:

Elastomeric Bearing Pads	M9.14.5
Anchor bolts	M8.01.5

CONSTRUCTION METHODS

922.50: Submittals

The Contractor shall submit the following to the Engineer for approval:

1. Prior to fabrication:
 - a. Written notification 30 days prior to the start of bearing production. The notification shall include the contract number, quantity, type, and size of bearing being produced, manufacturer’s name, and the name of the independent testing lab.
 - b. Shop drawings for approval in accordance with Subsection 5.02, 14 days prior to the start of bearing production.
2. At the time of bearing pad delivery:
 - a. A certificate of compliance (COC) certifying that the elastomeric bearing pads meet the requirements of the contract specifications. The COC shall be accompanied by:
 - A mill certificate for steel laminates used in bearings, where applicable.
 - Fabricator QC test reports.
 - b. Independent test results as required under Subsection 922.62.

922.51: Fabricators

Fabricators shall be in accordance with Subsection M9.14.5D.

922.52: Fabrication

Fabrication shall be in accordance with Subsection M9.14.5E.

In addition to the number of bearing pads required for the contract the Contractor shall order additional bearing pads as defined in Subsection M9.14.5G, in order to allow the Engineer to randomly select a bearing pad for testing in accordance with 922.72.

922.53: Packaging, Handling, & Storage

The bearing pads shall be packaged, handled, and stored in accordance with Subsection M9.14.5F.

All bearing devices and components shall be stored on the project in an area that provides protection from environmental and physical damage. When installed, bearings shall be clean and free of all foreign substances.

922.54 Installation

Bearing pads shall be installed only on concrete bridge seat bearing areas that have been prepared in accordance with Subsection 901.65A(3).

Bearing pads shall be installed by qualified personnel to the positions, elevations, and slopes shown on the plans and to the dimensions and offsets prescribed by the manufacturer. The bearing pads shall be adjusted, as necessary, to take into account the ambient temperature at installation and future movements of the bridge due to temperature changes, release of falsework, and shortening due to post-tensioning.

Elastomeric bearings shall be placed directly on the concrete surface provided that it is flat within the bearing area to within a tolerance of 0.005 times the smallest nominal dimension of the bearing as measured by a straight edge from peak to valley. Bearings shall be placed on surfaces that do not deviate from the specified bridge seat slope in any direction by more than 0.01 rad.

Any bearing areas that exceed these tolerances shall be brought into compliance by grouting or use of shims as directed by the Engineer before the weight of the structure acts on the bearing.

Bearings that have an internal tapered load plates shall be marked with an arrow that points up-station in order to properly align the slope of the internal tapered load plate with the centerline of the bridge.

Sole plates that sit on the bearing shall not be welded to the beam flange in the field unless at least 1.5 in. of the steel exists between the weld and the elastomer. In no case shall the elastomer or the bond be subjected to temperatures higher than 400°F.

No beams shall be erected until the bearings have been accepted by the Engineer.

CONTRACTOR QUALITY CONTROL

922.60: General

The Contractor shall provide a Quality Control System (QC System) to ensure that all materials and workmanship meet the required specifications.

922.61: Quality Control Inspection

The Contractor shall perform QC inspection of all work items addressed under this specification. Inspection activities during placement may be performed by qualified production personnel. The Contractor's QC personnel shall have overall responsibility for the QC inspection. The Contractor shall not rely on the results of the Engineer's Acceptance inspection for QC purposes. The Engineer shall be provided with the opportunity to monitor and witness all QC inspections.

QC inspection activities must address the following three primary components:

- a. Materials
- b. Environmental Conditions
- c. Workmanship

The minimum frequency of QC inspection activity shall be in accordance with the requirements below.

Table 922.61-1 - Minimum QC Inspection of Elastomeric Bearing Pads

Inspection Component	Inspection Attribute	Minimum Inspection Frequency	Point of Inspection	Inspection Method
Materials	Bearing Pad	Each Delivery	Bearing Pad	Check COC
	Geometry and Surface	Each Bearing Pad	Bearing Pad Surface	Visual Check & Check Measurement
Environmental Conditions	Temperature of Air	1 per Day	At Project Site	Check Measurement
Workmanship	Bridge Seat	Each Bearing Location	Bearing Pad Location	Visual Check
	Elevation	Each Bearing Pad	Bearing Pad Location	Check Measurement
	Orientation	Each Bearing Pad	Bearing Pad Location	Check Measurement

922.62: Quality Control Sampling and Testing Requirements

The Contractor shall have each Lot of bearing pads sampled and tested in accordance with Subsection M9.14.5G. This shall include both QC and compliant independent laboratory test results.

DEPARTMENT ACCEPTANCE

922.70: General

The Department shall sample and test bearing pads as part of its Acceptance activities. Independent testing shall also be used to supplement its testing.

922.71: Acceptance Inspection

The Engineer will perform Acceptance inspection to ensure that materials and completed work are in conformance with the contract requirements. Acceptance inspection is intended to visually assess the quality of each Lot produced and placed and will address only the inspection components of materials and workmanship in support of the Department’s final Acceptance determination. All Acceptance inspection activities by the Department will be performed independent of the Contractor’s QC inspection.

Table 922.71-1 – Department Acceptance Inspection of Elastomeric Bearing Pads

Inspection Component	Inspection Attribute	Minimum Inspection Frequency	Point of Inspection	Inspection Method
Materials	Bearing Pad	1 Per Bearing Pad	Bearing Pad Surface	Check COC
	Geometry and Surface	1 Per Bearing Pad	Bearing Pad Surface	Visual Check & Check Measurement
Workmanship	Elevation	1 per Bearing Pad	Bearing Pad Location	Check Measurement
	Orientation	1 per Bearing Pad	Bearing Pad Location	Check Measurement

922.72: Acceptance Sampling and Testing Requirements

For Acceptance samples taken by the Engineer at the project, the sampling rate shall be in accordance with Subsection M9.14.5G. Bearing pads shall be tested by the Department in accordance with Table M9.14.5-1.

922.73: Lot Acceptance Determination Based on Inspection Results

The Engineer's Acceptance inspection results will be used in the final Acceptance determination for all Lots. Prior to final Acceptance of each Lot produced and placed, the Engineer will evaluate all Acceptance inspection information for the Lot. The materials and product workmanship for the completed work will be evaluated for conformance with the plans and the requirements specified in Subsections 922.60, 922.61, and 922.62.

When the Acceptance information identifies deficiencies in either material quality or product workmanship, the location will be isolated and further evaluated by the Engineer through additional Acceptance inspection. Depending upon the findings of the additional Acceptance inspection activity, the Engineer will determine the disposition of the nonconforming work in accordance with Division I, Subsection 5.03, Conformity with Plans and Specifications.

922.74: Lot Acceptance Determination Based on Testing Data

Prior to final Acceptance of each Lot, the Engineer will evaluate all available QC, independent, and Acceptance testing data for the Lot to determine conformance with the minimum requirements in Subsection M9.14.5G and Table M9.14.5-1.

If a test result does not meet the minimum requirement, the Contractor and Engineer will further assess the quality to determine whether the material can remain in place.

If the Engineer's assessment determines that the material quality is not sufficient to permit the bearing pad to remain in place, the pad shall be removed and replaced. When a nonconforming bearing pad is corrected or replaced, the Engineer will perform Acceptance testing of the replacement bearing pad and evaluate the test results for conformance with the minimum requirements.

922.75: Final Lot Acceptance Determination

For each Lot produced and placed, the Engineer will evaluate all Acceptance inspection and testing data for the Lot. The final review and visual inspection shall be conducted jointly by the Contractor and Engineer. Any items that do not meet the requirements of the specifications and plans shall be addressed at this time, at no additional cost to the Department.

After each Lot is complete, including any corrective action, the Engineer will perform a final evaluation of all Acceptance data for the Lot. The Engineer will accept the Lot if the evaluation of all inspection and testing data for the Lot is in conformance with this specification and the contract documents.

When the above requirements have been met, the Engineer will accept all completed bearing pads.

COMPENSATION

922.80: Method of Measurement

Laminated Elastomeric Bearing Pads will be measured by each pad installed. Plain Elastomeric Bearing Pads will be measured by the square foot installed. The measured quantities do not include the additional bearings required for conformance and destructive testing.

922.81: Basis of Payment

Payment under this item shall be at the contract unit price. This price will include all materials, equipment, tools and labor, additional bearing pads for testing and all required testing necessary to complete the work.

922.82: Payment Items

- 921. Laminated Elastomeric Bearing Pad with Anchor Bolts Each
- 922. Laminated Elastomeric Bearing Pad without Anchor Bolts Each
- 923. Laminated Sliding Elastomeric Bearing Pad with Anchor Bolts Each
- 933. Plain Elastomeric Bearing Pad Square Foot

SECTION 970: DAMP-PROOFING

Subsection 970.30: General

Add the following material to this subsection.

Mortar..... M4.04.0

Subsection 970.40: General

Replace the second sentence in the second paragraph with the following.

All holes in concrete surfaces shall be satisfactorily filled with mortar before damp-proofing is applied.

SUBSECTION 983: REVETMENT

Subsection 983.64 Special Slope Paving Under Bridges

Replace the last sentence under B. Quarry Stone or Precast Concrete Blocks. with the following.

Mortar shall then be placed in the joints to the top of the paved surface.

Subsection 983.65 Channel Paving and Grouted Channel Paving

Replace the last sentence with the following.

The grout shall conform to M4.04.0: Grout, Mortar, and Concrete Products.

DIVISION III
MATERIALS SPECIFICATIONS

SECTION M4: CEMENT AND CEMENT CONCRETE MATERIALS

Subsection M4.02.00 Cement Concrete

Add the following to the end of this subsection.

Alkali Silica Reactivity - Resistant Portland Cement Concrete

All cement concrete and precast/prestressed concrete products shall be alkali silica reactivity-resistant. Proportion Portland cement concrete mixes to include materials that meet either the aggregate requirement or Alkali-Silica Reactivity (ASR) mitigation criteria listed below. Provide cement mill test reports from certified laboratories that show the materials' source, composition and the cement alkali content expressed as sodium oxide equivalent(s) not to exceed 1.4%. Certified test reports according to test procedures as specified in Table A will be required to be submitted with the trial batch submission to RMS for approval every year or whenever the source of material is changed.

Select non-reactive aggregates that meet all the criteria of Table M4.02.00-2. Mitigate the mix as described below when nonreactive aggregates are unavailable. If non-reactive aggregates are used for portland cement concrete mix, 15% by weight of the cementitious content shall be fly ash meeting AASHTO M 295, Type F.

Select a material or a combination of materials that meet the criteria shown in Table M4.02.00-3 to mitigate ASR when concrete mixes must be proportioned with reactive aggregates. Perform verification test according to AASHTO T 303 and ASTM C295 to determine the effectiveness of the resulting mix design against ASR. Use the same proportion of cement and pozzolan for each test mixture as that proposed for the actual mix design. Provide the Department with certified documentation of the mixtures' effectiveness to control ASR.

Table M4.02.00-2: Tests and Criteria for Proposed Aggregates

Procedure	Description	Limits
AASHTO T 303: Accelerated Detection of Potentially Deleterious Expansion of Mortar Bars Due to Alkali-Silica Reaction	Mean mortar bar expansion at 14 days. Perform a polynomial fit ⁽¹⁾ of 4, 7, 11, and 14 days to determine reliability of results	0.08% maximum metamorphic aggregate; 0.10% maximum all other aggregates. Repeat AASHTO T 303 if r ² is less than 0.95.
ASTM C295: Petrographic Examination of Aggregates for Concrete	Optically strained, microfractured, or microcrystalline quartz	5.0% maximum ⁽²⁾
	Chert or chalcedony	3.0% maximum ⁽²⁾
	Tridymite or cristobolite	1.0% maximum ⁽²⁾
	Opal	0.5% maximum ⁽²⁾
	Natural volcanic glass	3.0% maximum ⁽²⁾
⁽¹⁾ Use a second order polynomial of %Exp = A ⁰ + A ¹ SQRT(t) + A ² t. See publication SD92-04-F.		
⁽²⁾ Based on the total aggregate sample.		

Table M4.02.00-3: Mitigation Methods for ASR in Portland Cement Concrete

Material	Specification	Cementitious Material Percentage ⁽¹⁾
Low alkali cement ⁽²⁾	AASHTO M 85	100%
Fly ash - Class F	AASHTO M 295	15% minimum to 30% ⁽⁴⁾ maximum
Silica Fume ⁽⁵⁾	AASHTO M 307	6% ± 1% ⁽⁶⁾
Slag Grade 100 and 120	AASHTO M 302	25% minimum to 50% maximum

⁽¹⁾ Measure this minimum content of cementitious material as percent by weight of cement plus pozzolan.

⁽²⁾ This single criterion is not effective in all cases in remediating ASR. Low alkali cement (0.60% maximum ⁽³⁾) must be used in combination with other pozzolanic materials in Table B.

⁽³⁾ $\text{Na}_2\text{O equivalent} = \% \text{Na}_2\text{O} + 0.658 (\% \text{K}_2\text{O})$

⁽⁴⁾ Fly ash, Type F, shall replace 15% by weight of the design cement content, and any additional fly ash will be considered as fine aggregate.

⁽⁵⁾ Silica fume shall only be used in silica fume cement concrete.

⁽⁶⁾ The total amount of Type F fly ash and silica fume shall constitute 20% by weight of the design cement content, and any additional fly ash shall be considered as fine aggregate.

Subsection M4.02.15 Cement Mortar

Delete this subsection.

Subsection M4.04.0: Grout, Mortar and Concrete Products

Replace this subsection with the following.

M4.04.0: Grout, Mortar, and Concrete Products

Grout, cementitious mortar, and concrete products shall be packaged, dry, and preblended with preformulated constituent materials (excluding mixing water) to produce a material with acceptable quality characteristics and material properties, including time of set, compressive strength, flexural strength, slant shear bond strength, resistance to alkali silica reaction, freezing/thawing, and de-icing cycles, shrinkage, expansion, and sulfate reaction.

Mortar products shall be defined as products containing aggregate of which less than 5% by mass of the total mixture is retained on the 3/8 in. sieve. Mortar products for concrete repairs shall be used only on repair depths of 2 in. or less. Concrete products shall be defined as products containing aggregate of which 5% or more by mass of the total mixture is retained on the 3/8 in. sieve. Concrete products for concrete repairs shall be used only on repair depths greater than 2 in.

The aggregate sources included in the prepackaged product or extended into the product shall meet Section M4.02.02: Aggregates. Grout, cementitious mortar, and concrete products shall only be applied per the requirements provided on the product's technical data sheet. Grout, cementitious mortar, and concrete products shall maintain valid listing on the MassDOT Qualified Construction Materials List (QCML). Grout, cementitious mortar, and concrete products shall meet requirements specified herein.

A. Technical Data Sheet.

The Manufacturer shall submit the product's technical data sheet to the Department for review. At a minimum, the product's technical data sheets shall include:

- (a) Product Name
- (b) Manufacturer, including address and contact information
- (c) Packaging
- (d) Yield
- (e) Product Description, including an overview of the product and its intended application(s) and use(s).

- (f) Technical Data, including quality characteristics and corresponding performance criteria with the AASHTO and/or ASTM standard test methods identified.
- (g) Recommended Equipment
- (h) Instructions, including surface preparation, mixing, forming, placing, finishing, curing, and protection from adverse conditions, such as precipitation, cold conditions, and hot conditions.
- (i) Limitations
- (j) Storage and Shelf Life
- (k) Safety

B. Mix Design Formulation.

Products that are extended with aggregate not included in the original product packaging shall be formulated per the product's technical data sheet and evaluated through Department mix design evaluation and verification testing. Producers shall report and submit proposed mix design formulations onto the Department issued mix design sheet. The Producer shall select an AASHTO accredited independent laboratory to conduct verification testing. The sampling and testing conducted by the independent laboratory shall be witnessed by the Department.

C. Product Verification Testing.

Verification test results shall be within the limits specified herein.

M4.04.1: Conventional Grout, Cementitious Mortar, and Concrete Products

Conventional grout, cementitious mortar, and concrete products shall meet the requirements of Section M4: Cement and Cement Concrete Materials, performance criteria of the product's technical data sheet, and the requirements specified herein.

M4.04.2: Rapid Hardening Cementitious Mortar and Concrete Products

Rapid hardening cementitious mortar and concrete products shall meet the requirements and performance criteria of the product's technical data sheet, ASTM C928 Standard Specification for Packaged, Dry, Rapid-Hardening Cementitious Materials for Concrete Repairs, and Table M4.04.2-2.

Table M4.04.2-1: Types of Rapid Hardening Cementitious Products for Concrete Repairs

Type	Description	Application
R1	General Rapid Hardening	Vertical and Overhead Repairs
R2	Medium Rapid Hardening	Vertical and Overhead Repairs
R3	Very Rapid Hardening	Horizontal, Vertical, and Overhead Repairs

Table M4.04.2-2: Verification Testing Requirements

Property	Method	Quality Characteristic		Limits					
				R1		R2		R3	
				Min.	Max.	Min.	Max.	Min.	Max.
Setting	T 197	Initial Set (min.)		Technical Data Sheet					
		Final Set (min.)		Technical Data Sheet					
Strength	T 97 ^[1]	Flexural Strength (psi)	24 Hours	-	-	-	-	650	-
			7 Days	-	-	-	-	-	-
Durability	T 358	Surface Chloride Ion Penetration Resistance (kΩ-cm)	28 Days	21	-	21	-	21	-
			T 161 (A)	Relative Durability Factor		90	-	90	-
		Mass Loss (%)		-	6.0	-	6.0	-	6.0

[1] Not applicable to vertical and overhead repair applications.

M4.04.3: Mortar Products for Unit Masonry

Mortar products for unit masonry shall meet the requirements and performance criteria of the product’s technical data sheet and Type M specified in ASTM C270 Standard Specification for Mortar for Unit Masonry. Field proportioned cement mortar for laying brick and block shall be composed of 1 part Portland cement and 2 parts of fine aggregate by volume with a sufficient amount of water to form a workable mixture, while still achieving the properties specified herein.

M4.04.4: Grout Products for Unit Masonry

Grout products for unit masonry shall meet the requirements and performance criteria of the product’s technical data sheet and ASTM C476 Standard Specification for Grout for Masonry.

M4.04.5: Non-Shrink Grout Products

Non-shrink grout products are intended for use under applied load, including supporting a structure, transfer medium between load-bearing members, shear keys, and other non-shrink applications, where a change in height below initial placement height is to be avoided. Non-shrink grout products shall meet the requirements and performance criteria of the product’s technical data sheet and ASTM C1107 Standard Specification for Packaged Dry, Hydraulic-Cement Grout (Nonshrink).

SECTION M5: PIPE, CULVERT SECTIONS AND CONDUIT

Subsection M5.01.0: Joint Material for Pipe

Replace M4.02.15 Cement Mortar with M4.04.0 Grout, Mortar, and Concrete Products in paragraph B.

SECTION M8: METALS AND RELATED MATERIALS

Subsection M8.18.1: Traffic Signal Supports

Delete the heading Posts and the two paragraphs under it. Delete the heading Bases and the three paragraphs under it.

SECTION M9: MISCELLANEOUS MATERIALS

Subsection M9.14.5: Elastomeric Bridge Bearing Pads

Replace this subsection with the following:

M9.14.5: Elastomeric Bearing Pads**A. General Requirements**

Elastomeric bearing pads shall be plain or laminated. They shall meet the applicable requirements of AASHTO M 251, the MassDOT Bridge Manual, and the AASHTO LRFD Bridge Design and Construction Specifications. The type of bearing will be specified on the plans.

Laminated elastomeric bearing pads consist of layers of elastomers restrained at their interfaces by bonded metal laminates.

B. Material Requirements

Plain elastomeric bearing pads shall consist of elastomer.

Laminated elastomeric bearing pad shall consist of:

- Elastomer
- Internal Steel Laminates
- Tapered Internal Load Plates (if used)

The components of the elastomeric bearing pad shall conform to AASHTO M 251 and the following:

- The elastomer compound shall be 100% virgin neoprene and classified as being of low-temperature grade 3.
- The steel laminates shall meet the requirements of ASTM A 1011 Grade 36 or higher

C. Material Qualification

Elastomeric bearing pads shall be approved on a project basis. The Contractor shall furnish to the Research and Materials Section certified independent test reports demonstrating conformance. All testing shall be performed by the same independent lab in accordance with Subsection M9.14.5G.

D. Fabricators

Bearing shall be fabricated by a fabricator listed on the MassDOT Qualified Construction Materials List (QCML).

E. Fabrication

Fabrication shall not begin until the shop drawings have been approved and the Department has an inspector at the fabricator's facility.

The shop drawings shall specify bearing dimensions as shown on the plans and, where applicable, shall include:

- Elastomer thickness and edge cover,
- Number and thickness of steel reinforcing laminates,
- Dimensions of load plates (if any),
- Design shear modulus of the elastomer shall be as shown on the Plans.

Plain elastomeric bearing pads shall be fabricated and tested in accordance with the "Method A" design outlined in the AASHTO LRFD Bridge Design Specifications.

Laminated elastomeric bearing pads shall be fabricated and tested in accordance with the "Method B" design outlined in the AASHTO LRFD Bridge Design Specifications.

The manufacturer shall designate the bearings in each Lot, as described in Subsection M9.14.5G, and certify that each bearing in the Lot was manufactured in a reasonably continuous manner from the same batch of elastomer and cured under the same conditions. In addition, the manufacturer shall certify that each bearing in the Lot satisfies the requirements of this specification, AASHTO M 251, the AASHTO LRFD Bridge Construction Specifications, and the contract plans and documents.

The tolerances on the overall dimensions for the bearings shall be according to Table 2 of AASHTO M 251, except that the tolerance on the overall vertical dimension shall be limited to 0, +1/8" regardless of the design thickness.

All steel included in the final bearing product must conform to Buy America Requirements.

F. Packaging, Handling, & Storage

The bearing pads shall be packaged, handled, and stored as specified below:

Prior to shipment from the point of manufacture, bearings shall be packaged in such a manner to ensure that during shipment and storage the bearings will be protected against damage from handling, weather, or any normal hazard. Each completed bearing shall have its components clearly identified, be securely bolted, strapped, or otherwise fastened to prevent any relative movement, and be marked on its top as to location and orientation in each structure in the project in conformity with the contract documents.

Each elastomeric bearing shall be marked in indelible ink or flexible paint. The marking shall consist of the order number, lot number, bearing identification number, and elastomer type and grade per AASHTO M 251. For bearing pads fabricated with a tapered internal load plate, a 1/32" deep direction arrow shall be inscribed into the bearing which will allow the bearing to be aligned with the up-station direction. All marks shall be permanent and be visible after the bearing is installed.

G. Testing Requirements

Quality Control System

Fabricators shall perform Quality Control (QC) testing in accordance with their quality system. QC test reports shall accompany the bearing pads when delivered to the project.

Acceptance System

MassDOT will evaluate the fabricator's quality system and QC test reports. It will also perform its own testing and verify the independent laboratory's test reports, if applicable.

Lot Sizes

Sampling of bearing pads for testing shall be random and performed on a Lot basis. A Lot of bearings shall be a group of 100 or fewer bearings that are:

- For a single contract,
- Cured under the same conditions,
- The same size and configuration,
- Manufactured in a reasonably continuous manner from the same batch of elastomer.

Testing of Plain Bearings

Testing Laboratory

Plain elastomeric bearing pads shall be tested by both an independent laboratory and MassDOT:

- Independent testing shall be performed by a nationally recognized third-party laboratory approved by the Research & Materials Section.
- Acceptance testing shall be performed by the Research and Materials.

Sampling Frequency

Each Lot of plain bearings shall be randomly sampled for testing. The Contractor shall ensure that the fabricator produces the additional bearings required for testing.

Samples for independent testing shall be selected by the fabricator. The sampling rate for the independent

testing shall be as follows:

- Lot sizes less than 10 bearings – One full-size bearing per Lot.
- Lot sizes greater than or equal to 10 bearings – Two full-size bearings per lot.

Samples for Acceptance testing shall be selected by the Engineer. The sampling rate for Acceptance testing shall be one bearing pad per lot.

Testing Requirements

The laboratory shall test the bearings in accordance with Sections 8 and 9 of AASHTO M 251 as specified below:

1. Dimensions per Section 8.4.
2. Elastomer per Section 8.6.
 - The hardness, tensile strength, and ultimate elongation shall be in accordance with Table 1 of AASHTO M 251.
3. Test procedures per Section 8.9.
 - Heat resistance per Section 8.9.3.

Testing of Laminated Bearings

Testing Laboratory

Laminated elastomeric bearing pads shall be tested by both an independent laboratory and MassDOT:

- Independent testing shall be performed by a nationally recognized third-party laboratory approved by the Research & Materials Section.
- Acceptance testing shall be performed by the Research and Materials.

Sampling Frequency

Each Lot of laminated bearings shall be randomly sampled for testing. The Contractor shall ensure that the fabricator produces the additional bearings required for testing.

Samples for independent testing shall be selected by the fabricator. The sampling rate for the independent testing shall be as follows:

- Lot sizes less than 10 bearings – One full-size bearing per Lot.
- Lots sizes greater than or equal to 10 bearings:
 - One full-size bearing per every twenty per lot, or a minimum of two bearings.
 - The number of laminated bearings to sample shall be determined by taking the Lot size divided by 20. If the integer part of this calculation is 0 or 1, then two bearings shall be sampled. For example, if the lot size is 58 laminated bearings, two bearings shall be sampled; if the lot size is 65, three bearings shall be sampled; and if the lot size is 22, two bearings shall be sampled.

Samples for Acceptance testing shall be selected by the Engineer. The sampling rate for Acceptance testing shall be one bearing pad per lot.

Testing Requirements

Testing of the bearings shall be in accordance with Sections 8 and 9 of AASHTO M 251 as specified below:

1. Dimensions per Section 8.4.
2. Elastomer per Section 8.6.
 - The hardness, tensile strength, and ultimate elongation shall be in accordance with Table 1 of AASHTO M 251.
3. Compressive strain at the maximum design dead plus live service compressive load per Section 8.8.1.1.

- The compressive deflection, as determined per Section 9.1., between the two loadings for each bearing tested shall not exceed 10%.
- 4. Bond via Compressive Load per Section 8.8.2.2.
- 5. Shear Modulus of the elastomer per Section 8.8.3.
 - Shear modulus shall meet the requirements on the plans.
- 6. Test procedures per Section 8.9.
 - a. Additional Low Temperature Shear Modulus testing per Section 8.9.1.
 - b. Heat resistance per Section 8.9.3.
 - c. Compression set per Section 8.9.4.
 - d. Creep per Section 8.9.5.
 - The percent creep shall be less than 35%.
 - e. Long Term Compression per Section 8.9.6.

Table M9.14.5-1: Department Acceptance Testing of Elastomeric Bearing Pads

Quality Characteristic	Test Method	Requirement
Hardness	ASTM D2240	From Independent Test Results ± 5 Pts
Tensile Strength	ASTM D412	≥ 2250 psi
Ultimate Elongation	ASTM D412	Minimum Elongation Based on Durometer according to AASHTO M 251 Table 1
Shear Modulus (see Note 1)	ASTM D4014	Specified Value ± 15%
After Heat Aging for 70 Hours at 100°C (Maximum Change from Unaged Testing)		
Hardness	ASTM D573	Hardness + 15 Pts
Tensile Strength	ASTM D573	Tensile Strength - 15%
Ultimate Elongation	ASTM D573	Ultimate Elongation - 40%
Note 1: Test is only required for laminated elastomeric bearing pads.		

SECTION M10: TRAFFIC CONTROL DEVICES

Subsection M10.05.0: Traffic Signal Structures (General)

Add this new subsection.

M10.05.0: Traffic Signal Structures (General)

The bases of all Traffic Signal Structures shall be supplied with a bonding lug.

Subsection M10.05.1: Signal Posts and Bases

Add this new subsection.

M10.05.1: Signal Posts and Bases

All Signal Posts shall be one-piece 4-in. diameter, Schedule 40 or Schedule 80, and machine-threaded.

Signal Posts may be fabricated from aluminum with a brushed or spun finish or from steel with a galvanized finish.

The interior of Signal Posts shall be coated as specified in Underwriters Laboratories UL-6 for enameled conduit, or aluminum conduit conforming to M5.07.1: Electrical Conduit-Rigid Metallic (Type RM), Paragraph C.

Signal Posts Bases shall be fabricated to accept the threads from the Signal Post and locked into place with set screws.

THIS PAGE IS INTENTIONALLY LEFT BLANK

DOCUMENT 00719

(Revised September 14, 2023 – for all Federally Aided Projects)

**SPECIAL PROVISIONS FOR PARTICIPATION BY
DISADVANTAGED BUSINESS ENTERPRISES**
(IMPLEMENTING TITLE 49 OF THE CODE OF FEDERAL REGULATIONS, PART 26)

Section: Page 00719-

POLICY 2

1. DEFINITIONS..... 3

2. DBE PARTICIPATION 5

 a. Goal 5

 b. Bidders List..... 5

3. CONTRACTOR ASSURANCES 6

4. REQUIRED SUBCONTRACT PROVISIONS 6

5. ELIGIBILITY OF DBES 6

 a. Massachusetts DBE Directory 6

 b. DBE Certification 6

 c. Joint Venture Approval 7

6. COUNTING DBE PARTICIPATION TOWARDS DBE PARTICIPATION GOALS..... 7

 a. Commercially Useful Function 7

 b. Counting Participation Toward The Contract Participation Goal..... 7

 c. Joint Check Policy..... 9

 d. Joint Check Procedure(s) 10

7. AWARD DOCUMENTATION AND PROCEDURES 11

8. COMPLIANCE 13

9. SANCTIONS..... 16

10. FURTHER INFORMATION; ENFORCEMENT, COOPERATION AND
 CONFIDENTIALITY 16

11. LIST OF ADDITIONAL DOCUMENTS 18

POLICY

The Massachusetts Department of Transportation (MassDOT) receives Federal financial assistance from the Federal Highway Administration (FHWA), United States Department of Transportation (U.S. DOT), and as a condition of receiving this assistance, has signed an assurance that it will comply with 49 CFR Part 26 (Participation By Disadvantaged Business Enterprises In Department Of Transportation Financial Assistance Programs). The U.S. DOT Disadvantaged Business Enterprise Program is authorized by the Safe, Accountable, Flexible, Efficient Transportation Equity Act: A Legacy for Users (“SAFETEA-LU”), as amended, at Title 23, United States Code, § 1101.

Accordingly, MassDOT has established a Disadvantaged Business Enterprise (DBE) Program in accordance with 49 CFR Part 26. It is the policy of MassDOT to ensure that DBEs have an equal opportunity to receive and participate in U.S. DOT assisted Contracts, without regard to race, color, national origin, or sex. To this end, MassDOT shall not directly, or through contractual or other arrangements, use criteria or methods of administration that have the effect of defeating or substantially impairing accomplishment of the program objectives stated below:

- ◆ To ensure nondiscrimination in the award and administration of U.S. DOT assisted Contracts;
- ◆ To create a level playing field on which DBEs can compete fairly for U.S. DOT assisted Contracts;
- ◆ To ensure that the DBE Program is narrowly tailored in accordance with applicable law;
- ◆ To ensure that only firms that fully meet 49 CFR Part 26 eligibility standards are permitted to participate as DBEs;
- ◆ To help remove barriers to the participation of DBEs in U.S. DOT assisted Contracts; and
- ◆ To assist the development of firms that can compete successfully in the market place outside the DBE Program.

The Director of Civil Rights of MassDOT has been designated as the DBE Liaison Officer. The DBE Liaison Officer is responsible for implementing all aspects of the DBE Program. Other MassDOT employees are responsible for assisting the Office of Civil Rights in carrying out this obligation. Implementation of the DBE Program is accorded the same priority as compliance with all other legal obligations incurred by MassDOT in its financial assistance agreements with each operating administration of the U.S. DOT. Information on the Federal requirements and MassDOT’s policies and information can be found at:

<i>Type of Info</i>	<i>Website</i>	<i>Description</i>
MassDOT Highway Division Policies and Info	https://www.mass.gov/disadvantaged-business-enterprise-goals-2019-2022	MassDOT– Highway Div’n Page
For copies of the Code of Federal Regulations	http://www.gpo.gov/fdsys/browse/collectionCfr.action?collectionCode=CFR	FDsys – US Gov’t Printing Office
For information about the U.S.DOT DBE Program	https://www.transportation.gov/civil-rights/disadvantaged-business-enterprise	U.S. DOT/ FHWA page

1. DEFINITIONS

As used in these provisions, the terms set out below are defined as follows:

“Broker”, for purposes of these provisions, shall mean a DBE Entity that has entered into a legally binding relationship to provide goods or services delivered or performed by a third party. A broker may be a DBE Entity that arranges or expedites transactions but performs no work or installation services.

“Contractor”, “General” or “Prime” Contractor, “Bidder,” and “DB Entity” shall mean a person, firm, or other entity that has contracted directly with MassDOT to provide contracted work or services.

“Contract” shall mean the Contract for work between the Contractor and MassDOT.

“DBB” or “Design-Bid-Build” shall mean the traditional design, bid and project delivery method consisting of separate contracts between awarding authority and a designer resulting in a fully designed project; and a separate bidding process and Contract with a construction Contractor or Bidder.

“DB” or “Design-Build” shall mean an accelerated design, bid and project delivery method consisting of a single contract between the awarding authority and a DB Entity, consisting of design and construction companies that will bring a project to full design and construction.

“Disadvantaged Business Enterprise” or “DBE” shall mean a for-profit, small business concern:

- (a) that is at least fifty-one (51%) percent owned by one or more individuals who are both socially and economically disadvantaged, or, in the case of any corporation, in which at least fifty-one (51%) percent of the stock is owned by one or more such individuals; and
- (b) where the management and daily business operations are controlled by one or more of the socially and economically disadvantaged individuals who own it.

“FHWA” shall mean the Federal Highway Administration,” an agency within U.S. DOT that supports State and local governments in the design, and maintenance of the Nation’s highway system (Federal Aid Highway Program).

“Good faith efforts” shall mean efforts to achieve a DBE participation goal or other requirement of these Special Provisions that, by their scope, intensity, and appropriateness to the objective, can reasonably be expected to fulfill the program requirement. Such efforts must be deemed acceptable by MassDOT.

“Joint Venture” shall mean an association of a DBE firm and one or more other firms to carry out a single, for-profit business enterprise, for which the parties combine their property, capital, efforts, skills and knowledge, and in which the DBE is responsible for a distinct, clearly defined portion of the work of the Contract and whose share in the capital contribution, control, management, risks, and profits of the joint venture are commensurate with its ownership interest.

“Approved Joint Venture” shall mean a joint venture, as defined above, which has been approved by MassDOT’s Prequalification Office and Office of Civil Rights for DBE participation on a particular Contract.

"Manufacturer" shall mean a firm that operates or maintains a factory or establishment that produces, on the premises, the materials, supplies, articles or equipment required under the contract and of the general character described by the specifications.

"Regular Dealer" shall mean a DBE firm that owns, operates, or maintains a store, warehouse, or other establishment in which materials, supplies, articles or equipment of the general character described by the specifications and required under the Contract are bought, kept in stock, and regularly sold or leased to the public in the usual course of business.

- (a) To be a regular dealer, the firm must be an established, regular business that engages, as its principal business, and under its own name, in the purchase and sale of the products in question.
- (b) A person may be a regular dealer in such bulk items as petroleum products, steel, cement, gravel, stone, or asphalt without owning, operating, or maintaining a place of business as provided above if the person both owns and operates distribution equipment for the products. Any supplementing of regular dealers' own distribution equipment shall be by long term lease agreement and not on an ad hoc or contract by contract basis.
- (c) Packagers, brokers, manufacturers' representatives, or other persons who arrange or expedite transactions are not regular dealers within the meaning of this definition.

"Responsive" and "Responsible" refers to the bidder's submittal meeting all of the requirements of the advertised request for proposal. The term responsible refers to the ability of the Contractor to perform the work. This ability can be determined prior to bid invitations.

"Small Business or Small Business Concern" shall mean a small business concern or company as defined in Section 3 of the Small Business Act and SBA regulations implementing it (13 CFR Part 121); and is a business that does not exceed the cap on annual average gross receipts established by the U.S. Secretary of Transportation pursuant to 49 CFR Part 26.65; see also 49 CFR Part 26.39.

"SDO" shall mean the Massachusetts Supplier Diversity Office, formerly known as the State Office of Minority and Women Business Assistance (SOMWBA). In 2010, SOMWBA was abolished and the SDO was established. *See* St. 2010, c. 56. The SDO has assumed all the functions of SOWMBA. SDO is an agency within the Commonwealth of Massachusetts Executive office of Administration and Finance (ANF) Operational Services Division (OSD). The SDO mandate is to help promote the development of business enterprises and non-profit organizations owned and operated by minorities and women.

"Socially and economically disadvantaged individuals" shall mean individuals who are citizens of the United States (or lawfully admitted permanent residents) and who are:

- (a) Individuals found by SDO to be socially and economically disadvantaged individuals on a case by case basis.
- (b) Individuals in the following groups, members of which are rebuttably presumed to be socially and economically disadvantaged:

- (1) "Black Americans" which includes persons having origin in any of the Black racial groups of Africa; (2) "Hispanic Americans" which include persons of Mexican, Puerto Rican, Cuban, Dominican, Central or South American, or other Spanish or Portuguese culture or origin, regardless of race; (3) "Native Americans" which include persons who are American Indians, Eskimos, Aleuts, or Native Hawaiians; (4) "Asian Pacific Americans" which includes persons whose origins are from Japan, China, Taiwan, Korea, Burma (Myanmar), Vietnam, Laos, Cambodia (Kampuchea), Thailand, Malaysia, Indonesia, the Philippines, Brunei, Samoa, Guam, the U.S. Trust Territories of the Pacific Islands (Republic of Palau), the Commonwealth of the Northern Marianas Islands, Macao, Fiji, Tonga, Kiribati, Tuvalu, Nauru, Federated States of Micronesia, or Hong Kong; (5) "Subcontinent Asian Americans" which includes persons whose origins are from India, Pakistan, Bangladesh, Bhutan, the Maldives Islands, Nepal or Sri Lanka; (6) Women; or (7) Any additional groups whose members are designated as socially and economically disadvantaged by the Small Business Administration (SBA), at such time as the SBA designation becomes effective.

Other terms and definitions applicable to the U.S. DOT DBE Program may be found at 49 CFR Part 26 and related appendices and guidance pages.

2. DBE PARTICIPATION

a. Goal

On this Contract, MassDOT has established the following goal(s) for participation by firms owned and controlled by socially and economically disadvantaged persons. At least half of the goal must be met in the form of DBE Subcontractor construction activity as opposed to material supplies or other services. The applicable goal remains in effect throughout the life of the contract regardless of whether pre-identified DBE Subcontractors remain on the Project or under Contract.

Design-Bid-Build Projects: DBE Participation Goal ____%
(One half of this goal shall be met in the form of Subcontractor construction activity)

Design-Build Projects: DBE Design Participation Goal ____% and DBE Construction Participation Goal ____%
(One half of the Construction Goal shall be met in the form of Subcontractor construction activity)

b. Bidders List

Pursuant to the provisions of 49 CFR Part 26.11(c), Recipients such as MassDOT, must collect from all Bidders who seek work on Federally assisted Contracts the firm full company name(s), addresses and telephone numbers of all firms that have submitted bids or quotes to the Bidders in connection with this Project. All bidders should refer to the Special Provision Document "A00801" of the Project proposal for this requirement.

In addition, MassDOT must provide to U.S. DOT, information concerning contractors firm status as a DBE or non-DBE, the age of the firm, and the annual gross receipts of the firm within a series of brackets (e.g., less than \$500,000; \$500,000–\$1 million; \$1–2 million; \$2–5 million, etc.). The status, firm age, and annual gross receipt information will be sought by MassDOT regularly prior to setting its DBE participation goal for submission to U.S. DOT. MassDOT will survey each individual firm for this information directly.

Failure to comply with a written request for this information within fifteen (15) business days may result in the suspension of bidding privileges or other such sanctions, as provided for in Section 9 of this provision, until the information is received.

3. CONTRACTOR ASSURANCES

No Contractor or any Subcontractor shall discriminate on the basis of race color, national origin, or sex in the performance of this contract. The Contractor shall carry out applicable requirements of 49 CFR Part 26 in all respects and as applicable prior to, or subsequent to, award of U.S. DOT assisted Contracts. The Contractor agrees to affirmatively seek out and consider DBE firms as Contractors, Subcontractors, and/or suppliers of materials and services for this Contract. No Contract will be approved until MassDOT has reviewed Bidders'/Contractors' affirmative actions concerning DBEs. Failure to carry out these requirements is a material breach of this Contract which may result in the termination of the Contract or such other remedy as MassDOT or FHWA deem appropriate.

4. REQUIRED SUBCONTRACT PROVISIONS

The Prime Contractor shall include the provisions of Section 3 above in every subcontract, making those provisions binding on each Subcontractor; in addition, the Prime Contractor shall include a copy of this Special Provision, in its entirety, in every subcontract with a DBE firm which is, or may be, submitted for credit toward the Contract participation goal.

5. ELIGIBILITY OF DBES

Only firms that have been certified by SDO and confirmed by MassDOT as eligible in accordance with 49 CFR Part 26 to participate as DBEs on federally aided MassDOT Contracts may be used on this Contract for credit toward the DBE participation goal.

a. Massachusetts DBE Directory

MassDOT makes available to all bidders the most current Massachusetts Disadvantaged Business Enterprise Directory. This directory is made available for Contractors' convenience and is informational only. The Directory lists those firms that have been certified as eligible in accordance with the criteria of 49 CFR Part 26 to participate as DBEs on federally aided MassDOT contracts. The Directory also lists the kinds of work each firm is certified to perform but does not constitute an endorsement of the quality of performance of any business and does not represent MassDOT Subcontractor approval.

Contractors are encouraged to make use of the DBE Directory maintained by SDO on the Internet.

This listing is updated daily and may be accessed at the SDO's website at:

<https://www.diversitycertification.mass.gov/BusinessDirectory/BusinessDirectorySearch.aspx>

b. DBE Certification

A firm must apply to SDO, currently acting as certification agent for MassDOT, for DBE certification to participate on federally aided MassDOT Contracts. A DBE application may be made in conjunction with a firm's application to SDO for certification to participate in state-funded minority and women business enterprise programs or may be for DBE certification only. An applicant for DBE certification must identify the area(s) of work it seeks to perform on U.S. DOT funded projects.

c. Joint Venture Approval

To obtain recognition as an approved DBE Joint Venture, the parties to the joint venture must provide to MassDOT's Office of Civil Rights and Prequalification Office, at least fourteen (14) business days before the bid opening date, an Affidavit of DBE/Non-DBE Joint Venture in the form attached hereto, and including, but not limited to the following:

1. a copy of the Joint Venture Agreement;
2. a description of the distinct, clearly defined portion of the contract work that the DBE will perform with its own forces; and,
3. all such additional information as may be requested by MassDOT for the purpose of determining whether the joint venture is eligible.

6. COUNTING DBE PARTICIPATION TOWARDS DBE PARTICIPATION GOALS

In order for DBE participation to count toward the Contract participation goal, the DBE(s) must have served a commercially useful function in the performance of the Contract and must have been paid in full for acceptable performance.

a. Commercially Useful Function

- (1) In general, a DBE performs a commercially useful function when it is responsible for execution of the work of the contract and is carrying out its responsibilities by actually performing, managing, and supervising the work involved. With respect to materials and supplies used on the Contract, the DBE must be responsible for negotiating price, determining quality and quantity, ordering the material, installing (where applicable) and paying for the material itself.
- (2) To determine whether a DBE is performing a commercially useful function, MassDOT will evaluate the amount of work subcontracted, industry practices, whether the amount the firm is to be paid under the Contract is commensurate with the work it is actually performing and the DBE credit claimed for its performance of the work, and other relevant factors.
- (3) A DBE does not perform a commercially useful function if its role is limited to that of an extra participant in a transaction, contract, or project through which funds are passed in order to obtain the appearance of DBE participation. In determining whether a DBE is such an extra participant, MassDOT will examine similar transactions, particularly those in which DBEs do not participate.

b. Counting Participation Toward The Contract Participation Goal

DBE participation which serves a commercially useful function shall be counted toward the DBE participation goal in accordance with the Provisions of 49 CFR Part 26.55(a) to (h), as follows:

- (1) When a DBE participates in a construction Contract, MassDOT will count the value of the work performed by the DBE's own forces. MassDOT will count the cost of supplies and materials obtained by the DBE for the work of its contract, including supplies purchased or equipment leased by the DBE. Supplies, labor, or equipment the DBE Subcontractor uses, purchases, or leases from the Prime Contractor or any affiliate of the Prime Contractor will not be counted.

-
- (2) MassDOT will count the entire amount of fees or commissions charged by a DBE firm for providing bona fide services, such as professional, technical, consultant, or managerial services, or for providing bonds or insurance specifically required for the performance of a U.S. DOT assisted Contract, toward DBE participation goals, provided it is determined that the fee is reasonable and not excessive as compared with fees customarily allowed for similar services.
 - (3) When a DBE performs as a participant in a joint venture, MassDOT will count toward DBE participation goals a portion of the total dollar value of the contract that is equal to the distinct, clearly defined portion of the work of the Contract that the DBE performs with its own forces.
 - (4) MassDOT will use the following factors in determining whether a DBE trucking company is performing a commercially useful function:
 - (i) the DBE must be responsible for the management and supervision of the entire trucking operation for which it is responsible on a particular contract; there cannot be a contrived arrangement for the purpose of meeting DBE participation goals.
 - (ii) the DBE must itself own and operate at least one fully licensed, insured, and operational truck used on the Contract.
 - (iii) the Contractor will receive DBE credit for the total value of the transportation services the DBE provides on the Contract using trucks owned, insured, and operated by the DBE itself and using drivers the DBE employs alone.
 - (iv) the DBE may lease trucks from another DBE firm, including an owner-operator who is certified as a DBE. The Contractor who has a contract with a DBE who leases trucks from another DBE will receive credit for the total value of the transportation services of the lease.
 - (v) the DBE may also lease trucks from a non-DBE firm, including an owner-operator. The Contractor who has a Contract with a DBE who leases trucks from a non-DBE is entitled to credit for the total value of the transportation services provided by non-DBE lessees not to exceed the value of transportation services provided by DBE-owned trucks on the Contract. Additional participation by non-DBE lessees receives credit only for the fee or commission it receives as a result of the lease arrangement, fee or commission it receives as a result of the lease arrangement. The DBE does not receive credit for the total value of the transportation services provided by the lessee, since these services are not provided by a DBE.
 - (vi) the lease must indicate that the DBE has exclusive use of, and control over, the truck. This does not preclude the leased truck from working for others during the term of the lease with the consent of the DBE, so long as the lease gives the DBE absolute priority for use of the leased truck. Leased trucks must display the name and identification number of the DBE.
-

- (5) MassDOT will count the Prime Contractor's expenditures with DBEs for materials or supplies toward DBE participation goals as follows:
- (i) if the materials or supplies are obtained from a DBE manufacturer, as defined in Section 1 above, MassDOT will count one hundred (100%) percent of the cost of the materials or supplies toward DBE participation goals, provided the DBE meets the other requirements of the regulations.
 - (ii) if the materials or supplies are purchased from a DBE regular dealer, as defined in Section 1 above, MassDOT will count sixty (60%) percent of the cost of the materials or supplies toward the Contract participation goal, provided the DBE meets the other requirements of the regulations.
 - (iii) for materials or supplies purchased from a DBE which is neither a manufacturer nor a regular dealer, MassDOT will count the entire amount of fees or commissions charged for assistance in the procurement of the materials and supplies, or fees or transportation charges for the delivery of materials or supplies required on a job site toward the Contract participation goal, provided that MassDOT determines the fees to be reasonable and not excessive as compared with fees customarily allowed for similar services; the cost of the materials and supplies themselves will not be counted; and provided the DBE meets the other requirements of the regulations.

c. Joint Check Policy

MassDOT recognizes that the use of joint checks may be a business practice required by material suppliers and vendors in the construction industry. A joint check is a two-party check issued by a/the Prime Contractor to a DBE third party such as a regular dealer of material or supplies. The Prime Contractor issues the check as payor to the DBE and the third party jointly as payees to guarantee payment to the third party for materials or supplies obtained or to be used by the DBE. FHWA has established criteria to ensure that DBEs are in fact performing a commercially useful function ("CUF") while using a joint check arrangement. Contractors and DBEs must meet and conform to these conditions and criteria governing the use of joint checks.

In the event that a Contractor or DBE Subcontractor desires to use a joint check, MassDOT will require prior notice and will closely monitor the arrangement for compliance with FHWA regulations and guidance. MassDOT may allow a joint check arrangement and give credit to a Contractor for use of the DBE where one or more of the following conditions exist:

- The use of a joint check is in fact required by this type of vendor or supplier as a standard industry practice that applies to all Contractors (DBEs and non-DBEs); or is required by a specific vendor or supplier;
- Payment for supplies or materials would be delayed for an unreasonably extended period without the joint check arrangement;
- The DBE (or any of its Subcontractors) has a pattern or history of not paying a vendor or supplier within a reasonable time or has not established enough of a credit history with the supplier or vendor; and/or
- The presence of severe adverse economic conditions, where credit resources may be limited and such practices may be necessary or required to effect timely payments.

Other factors MassDOT may consider:

- Whether there is a requirement by the Prime Contractor that a DBE should use a specific vendor or supplier to meet their Subcontractor specifications;
- Whether there is a requirement that a DBE use the Prime Contractor's negotiated price;
- The independence of the DBE;
- Whether approval has been sought prior to use of a joint check arrangement; and
- Whether any approved joint check arrangement has exceeded a reasonable period of use;
- The operation of the joint check arrangement; and
- Whether the DBE has made an effort to establish alternate arrangements for following periods (i.e., the DBE must show it can, or has, or why it has not, established or increased a credit line with the vendor or supplier).

Even with the use of a Joint Check, both the Contractor and DBE remain responsible for compliance with all other elements under 49 CFR § 26.55 (c) (1), and must still be able to prove that a commercially useful function is being performed for the Contractor.

d. Joint Check Procedure(s)

- The DBE advises its General or Prime Contractor that it will have to use a Joint Check and provide proof of such requirement.
- The General or the Prime Contractor submits a request for approval to MassDOT, using MassDOT's approved Joint Check Request form (Document B00855) and by notification on the DBE Letter of Intent (Document B00854), and any other relevant documents. Requests that are not initiated during the bid process should be made in writing and comply with the procedure.
- The MassDOT Office of Civil Rights will review the request and render a decision as part of the approval process for DBE Schedules and Letters of Intent.
- Review and Approval will be project specific and relevant documents will be made part of the project Contract file.
- Payments should be made in the name of both the DBE and vendor or supplier. Payments should be issued and signed by the Contractor as only the guarantor for prompt payment of purchases to the vendor or supplier. The payment to the vendor or supplier should be handled by the DBE (i.e. if possible, funds or the joint check should be processed by the DBE and sent by the DBE to the vendor or supplier).
- MassDOT may request copies of cancelled checks (front and back) and transmittal information to verify any payments made to the DBE and vendor or supplier.
- MassDOT may request other information and documents, and may ask questions of the Contractor, Subcontractor and vendor or supplier prior to, during, and after the project performance to ascertain whether the Subcontractor is performing a commercially useful function and all parties are complying with DBE Program policies and procedures as part of the Subcontractor approval process.

7. AWARD DOCUMENTATION AND PROCEDURES

- a. The two lowest bidders/the two bidders with the lowest price per quality score point, shall submit, by the close of business on the third (3rd) business day after the bid opening, a completed Schedule of Participation by DBEs (Document B00853) which shall list:
- (1) The full company name, address and telephone number of each DBE with whom the bidder intends to make a commitment.
 - (2) The contract item(s), by number(s) and quantity(ies), if applicable, or specific description of other business activity to be performed by each DBE as set forth in the Letters of Intent. The Bidder shall list only firms which have the capacity to perform, manage and supervise the work proposed in accordance with the requirements of 49 CFR Part 26 and Section **6.b** of these Special Provisions.
 - (3) The total dollar amount to be paid to each DBE. (Bidders are cautioned that at least one half of the participation goal must be met with construction activity work.)
 - (4) The total dollar amount to be paid to each DBE that is eligible for credit toward the DBE participation goal under the counting rules set out in Section **6.b**.
 - (5) The total creditable DBE participation as a percentage of the total bid price.
- b. All firms listed on the Schedule must be currently certified.
- c. The two lowest bidders/the two bidders with the lowest price per quality score point, shall each submit, with their Schedules of Participation, fully completed, signed Letters of Intent (Document B00854) from each of the DBEs listed on the Schedule. The Letters of Intent shall be in the form attached and shall identify specifically the contract activity the DBE proposes to perform, expressed as contract item number, if applicable, description of the activity, NAICS code, quantity, unit price and total price. In the event of discrepancy between the Schedule and the Letter of Intent, the Letter of Intent shall govern.
- d. Evidence of good faith efforts will be evaluated by MassDOT in the selection of the lowest responsible bidder.

All information requested by MassDOT for the purpose of evaluating the Contractor's efforts to achieve the participation goal must be provided within three (3) calendar days and must be accurate and complete in every detail. The apparent low bidder's attainment of the DBE participation goal or a satisfactory demonstration of good faith efforts is a prerequisite for award of the Contract.

- e. Failure to meet, or to demonstrate good faith efforts to meet, the requirements of these Special Provisions shall render a bid non-responsive. Therefore, in order to be eligible for award, the bidder (1) must list all DBE's it plans to employ on the Schedule of Participation; and provide the required Letters of Intent for, DBE participation which meets or exceeds the Contract goal in accordance with the terms of these Special Provisions or (2) must demonstrate, to the satisfaction of MassDOT, that good faith efforts were made to achieve the participation goal. MassDOT will adhere to the guidance provided in Appendix A to 49 CFR Part 26 on the determination of a Contractor's good faith efforts to meet the DBE participation goal(s) set forth in Section 2 herein.

- f. If MassDOT finds that the percentage of DBE participation submitted by the bidder on its Schedule does not meet the Contract participation goal, or that Schedule and Letters of Intent were not timely filed, and that the bidder has not demonstrated good faith efforts to comply with these requirements, it shall propose that the bidder be declared ineligible for award. In that case, the bidder may request administrative reconsideration. Such requests must be sent in writing within three (3) calendar days of receiving notice of proposed ineligibility to: The Office of the General Counsel, Massachusetts Department of Transportation, 10 Park Plaza, Boston, MA, 02116.
- g. If, after administrative reconsideration, MassDOT finds that the bidder has not shown that sufficient good faith efforts were made to comply with the requirements of these Special Provisions, it shall reject the bidder's proposal and may retain the proposal guaranty.
- h. Actions which constitute evidence of good faith efforts to meet a DBE participation goal include, but are not limited to, the following examples, which are set forth in 49 CFR Part 26, Appendix A:
- (1) Soliciting through all reasonable and available means (e.g., attendance at pre-bid meetings, advertising and/or written notices) the interest of all certified DBEs who have the capability to perform the work of the Contract. The bidder must solicit this interest within sufficient time to allow the DBEs to respond to the solicitation. The bidder must determine with certainty if the DBEs are interested by taking appropriate steps to follow up initial solicitations.
 - (2) Selecting portions of the work to be performed by DBEs in order to increase the likelihood that the DBE participation goal will be achieved. This includes, where appropriate, breaking out contract work items into economically feasible units to facilitate DBE participation, even when the Prime Contractor might otherwise prefer to perform these work items with its own forces.
 - (3) Providing interested DBEs with adequate information about the plans, specifications, and requirements of the contract in a timely manner to assist them in responding to a solicitation.
 - (4) Negotiating in good faith with interested DBEs. It is the bidder's responsibility to make a portion of the work available to DBE Subcontractors and suppliers and to select those portions of the work or material needs consistent with the available DBE Subcontractors and suppliers, so as to facilitate DBE participation. Evidence of such negotiation includes the names, addresses, and telephone number of DBEs that were considered; a description of the information provided regarding the plans and specifications for the work selected for subcontracting; and evidence as to why additional agreements could not be reached for DBEs to perform the work.

A bidder using good business judgment would consider a number of factors in negotiating with Subcontractors, including DBE Subcontractors, and would take a firm's price and capabilities as well as Contract participation goals into consideration. However, the fact that there may be some additional costs involved in finding and using DBEs is not in itself sufficient reason for a bidder's failure to meet the Contract DBE participation goal, as long as such costs are reasonable. Also, the ability or desire of a Prime Contractor to perform the work of a Contract with its own organization does not relieve the bidder of the responsibility to make good faith efforts. Prime Contractors are not, however, required to accept higher quotes from DBEs if the price difference is excessive or unreasonable.

- (5) Not rejecting DBEs as being unqualified without sound reasons based on a thorough investigation of their capabilities. Contractors should be careful of adding additional requirements of performance that would in effect limit participation by DBEs or any small business. The Contractor's standing within its industry, membership in specific groups, organizations, or associations and political or social affiliations (for example union vs. nonunion employee status) are not legitimate causes for the rejection or non-solicitation of bids in the Contractor's efforts to meet the Contract participation goal.
- (6) Making efforts to assist interested DBEs in obtaining bonding, lines of credit, or insurance as required by the recipient or contractor.
- (7) Making efforts to assist interested DBEs in obtaining necessary equipment, supplies, materials, or related assistance or services.
- (8) Effectively using the services of available minority/women community organizations; minority/women contractors' groups; local, state, and federal minority/women business assistance offices; and other organizations as allowed on a case by case basis to provide assistance in the recruitment and placement of DBEs.

8. COMPLIANCE

- a. All activity performed by a DBE for credit toward the Contract participation goal must be performed, managed and supervised by the DBE in accordance with all commercially useful function requirements of 49 CFR Part 26. The Prime Contractor shall not enter into, or condone, any other arrangement.
- b. The Prime Contractor shall not perform with its own organization, or assign to any other business, an activity designated for the DBE(s) named on the Schedule(s) submitted by the Prime Contractor under Section 7 or under paragraph 8.f of this section, without the approval of MassDOT in accordance with the requirements of paragraphs 8.f and 8.j of this section.
- c. MassDOT may suspend payment for any activity that was not performed by the DBE to whom the activity was committed on the approved Schedule of Participation, or that was not performed in accordance with the requirements of Section 6.
- d. MassDOT retains the right to approve or disapprove of any or all Subcontractors. Requests by the Prime Contractor for approval of participation by a DBE Subcontractor for credit toward the Contract participation goal must include, in addition to any other requirements for Subcontractor approval, the following:
 - (1) A copy of the proposed subcontract. The subcontract must be for at least the dollar amount, and for the work described, in the Bidder's Schedule of Participation.
 - (2) A resume stating the qualifications and experience of the DBE Superintendent and/or foreperson who will supervise the on-site work. A new resume will be required for any change in supervisory personnel during the progress of the work.
 - (3) A Schedule of Operations indicating when the DBE is expected to perform the work.
 - (4) A list of (1) equipment owned by the DBE to be used on the Project, and (2) equipment to be leased by the DBE for use on the Project.

- (5) A list of: (1) all projects (public and private) which the DBE is currently performing; (2) all projects (public and private) to which the DBE is committed; and (3) all projects (public and private) to which the DBE intends to make a commitment. For each Contract, list the contracting organization, the name and telephone number of a contact person for the contracting organization, the dollar value of the work, a description of the work, and the DBE's work schedule for each project.
- e. If, pursuant to the Subcontractor approval process, MassDOT finds that a DBE Subcontractor does not have sufficient experience or resources to perform, manage and supervise work of the kind proposed in accordance with the requirements of 49 CFR Part 26, approval of the DBE Subcontractor may be denied. In the event of such denial, the Prime Contractor shall proceed in accordance with the requirements paragraphs **8.f** and **8.j** of this section.
 - f. If, for reasons beyond its control, the Prime Contractor cannot comply with its DBE participation commitment in accordance with the Schedule of Participation submitted under Section 7, the Prime Contractor shall submit to MassDOT the reasons for its inability to comply with its obligations and shall submit, and request approval for, a revised Schedule of Participation. If approved by MassDOT, the revised Schedule shall govern the Prime Contractor's performance in meeting its obligations under these Special Provisions.
 - g. A Prime Contractor's compliance with the participation goal in Section 2 shall be determined by reference to the established percentage of the total contract price, provided, however, that no decrease in the dollar amount of a bidder's commitment to any DBE shall be allowed without the approval of MassDOT.
 - h. If the contract amount is increased, the Prime Contractor may be required to submit a revised Schedule of Participation in accordance with paragraphs **8.f** and **8.j** of this section.
 - i. In the event of the decertification of a DBE scheduled to participate on the Contract for credit toward the participation goal, but not under subcontract, the Contractor shall proceed in accordance with paragraphs **8.f** and **8.j** of this section.
 - j. The Prime Contractor shall notify MassDOT immediately of any facts that come to its attention indicating that it may or will be unable to comply with any aspect of its DBE obligation under this Contract.
 - k. Any notice required by these Special Provisions shall be given in writing to: (1) the Resident Engineer; (2) the District designated Compliance Officer; and (3) the DBE Liaison Officer, MassDOT Office of Civil Rights, 10 Park Plaza, – 3rd Floor - West, Boston, MA, 02116 and cc'd to the Deputy Chief of External Programs.
 - l. The Prime Contractor and its Subcontractors shall comply with MassDOT's Electronic Reporting System Requirements (MassDOT Document 00821) and submit all information required by MassDOT related to the DBE Special Provisions through the Equitable Business Opportunity Solution ("EBO"). MassDOT reserves the right to request reports in the format it deems necessary anytime during the performance of the Contract.
 - m. Termination of DBE by Prime Contractor
 - (1) A Prime Contractor shall not terminate a DBE Subcontractor or an approved substitute DBE firm without the prior written consent of MassDOT. This includes, but is not limited to, instances in which a Prime Contractor seeks to perform work originally designated for a DBE Subcontractor with its own forces or those of an affiliate, a non-DBE firm, or with another DBE firm.

-
- (2) MassDOT may provide such written consent only if MassDOT agrees, for reasons stated in its concurrence document, that the Prime Contractor has good cause to terminate the DBE firm.
 - (3) For purposes of this paragraph, good cause includes the following circumstances:
 - (i) The DBE Subcontractor fails or refuses to execute a written contract;
 - (ii) The DBE Subcontractor fails or refuses to perform the work of its subcontract in a way consistent with normal industry standards. Good cause, however, does not exist if the failure or refusal of the DBE Subcontractor to perform its work on the subcontract results from the bad faith or discriminatory action of the Prime Contractor;
 - (iii) The DBE Subcontractor fails or refuses to meet the Prime Contractor's reasonable, nondiscriminatory bond requirements.
 - (iv) The DBE Subcontractor becomes bankrupt, insolvent, or exhibits credit unworthiness;
 - (v) The DBE Subcontractor is ineligible to work on public works projects because of suspension and debarment proceedings pursuant 2 CFR Parts 180, 215 and 1,200 or applicable State law;
 - (vi) (vii) MassDOT has determined that the listed DBE Subcontractor is not a responsible contractor;
 - (vii) The listed DBE Subcontractor voluntarily withdraws from the Project and provides written notice of its withdrawal;
 - (viii) The listed DBE is ineligible to receive DBE credit for the type of work required;
 - (ix) A DBE owner dies or becomes disabled with the result that the listed DBE Contractor is unable to complete its work on the Contract;
 - (x) Other documented good cause that MassDOT determines compels the termination of the DBE Subcontractor. Good cause, however, does not exist if the Prime Contractor seeks to terminate a DBE it relied upon to obtain the Contract so that the Prime Contractor can self-perform the DBE work or substitute another DBE or non-DBE Contractor after Contract Award.
 - (4) Before transmitting to MassDOT a request to terminate and/or substitute a DBE Subcontractor, the Prime Contractor must give notice in writing to the DBE Subcontractor, with a copy to MassDOT, of its intent to request to terminate and/or substitute, and the reason for the request.
 - (5) The Prime Contractor must give the DBE five (5) business days to respond to the Prime Contractor's notice. The DBE must advise MassDOT and the Contractor of the reasons, if any, why it objects to the proposed termination of its subcontract and why MassDOT should not approve the Prime Contractor's action. If required in a particular case as a matter of public necessity (e.g., safety), MassDOT may provide a response period shorter than five (5) business days.
 - (6) In addition to post-award terminations, the provisions of this section apply to pre-award deletions of or substitutions for DBE firms.
-

n. Prompt Payment.

Contractors are required to promptly pay Subcontractors under this Prime Contract within ten (10) business days from the receipt of each payment the Prime Contractor receives from MassDOT. Failure to comply with this requirement may result in the withholding of payment to the Prime Contractor until such time as all payments due under this provision have been received by the Subcontractor(s) and/or referral to the Prequalification Committee for action which may affect the Contractor's prequalification status.

9. SANCTIONS

If the Prime Contractor does not comply with the terms of these Special Provisions and cannot demonstrate to the satisfaction of MassDOT that good faith efforts were made to achieve such compliance, MassDOT may, in addition to any other remedy provided for in the Contract, and notwithstanding any other provision in the Contract:

- a. Retain, in connection with final acceptance and final payment processing, an amount determined by multiplying the total contract amount by the percentage in Section 2, less the amount paid to approved DBE(s) for work performed under the Contract in accordance with the provisions of Section 8.
- b. Suspend, terminate or cancel this Contract, in whole or in part, and call upon the Prime Contractor's surety to perform all terms and conditions in the Contract.
- c. In accordance with 720 CMR 5.05(1)(f), modify or revoke the Prime Contractor's Prequalification status or recommend that the Prime Contractor not receive award of a pending Contract. The Prime Contractor may appeal the determination of the Prequalification Committee in accordance with the provisions of 720 CMR 5.06.
- d. Initiate debarment proceedings pursuant to M.G.L. c. 29 §29F and, as applicable, 2 CFR Parts 180, 215 and 1,200.
- e. Refer the matter to the Massachusetts Attorney General for review and prosecution, if appropriate, of any false claim or pursuant to M.G.L. c. 12, §§ 5A to 5O (the Massachusetts False Claim Act).
- f. Refer the matter to the U.S. DOT's Office of the Inspector General or other agencies for prosecution under Title 18, U.S.C. § 1001, 49 CFR Parts 29 and 31, and other applicable laws and regulations.

10. FURTHER INFORMATION; ENFORCEMENT, COOPERATION AND CONFIDENTIALITY.

- a. Any proposed DBE, bidder, or Contractor shall provide such information as is necessary in the judgment of MassDOT to ascertain its compliance with the terms of this Special Provision. Further, pursuant to 49 CFR, Part 26.107:

- (1) If you are a firm that does not meet the eligibility criteria of 49 CFR, Parts 26.61 to 26.73 (“subpart D”), that attempts to participate in a DOT- assisted program as a DBE on the basis of false, fraudulent, or deceitful statements or representations or under circumstances indicating a serious lack of business integrity or honesty, MassDOT or FHWA may initiate suspension or debarment proceedings against you under 49 CFR Part 29.
 - (2) If you are a firm that, in order to meet DBE Contract participation goals or other DBE Program requirements, uses or attempts to use, on the basis of false, fraudulent or deceitful statements or representations or under circumstances indicating a serious lack of business integrity or honesty, another firm that does not meet the eligibility criteria of subpart D, FHWA may initiate suspension or debarment proceedings against you under 49 CFR Part 29.
 - (3) In a suspension or debarment proceeding brought either under subparagraph a.(1) or b.(2) of this section, the concerned operating administration may consider the fact that a purported DBE has been certified by a recipient. Such certification does not preclude FHWA from determining that the purported DBE, or another firm that has used or attempted to use it to meet DBE participation goals, should be suspended or debarred.
 - (4) FHWA may take enforcement action under 49 CFR Part 31, Program Fraud and Civil Remedies, against any participant in the DBE Program whose conduct is subject to such action under 49 CFR Part 31.
 - (5) FHWA may refer to the Department of Justice, for prosecution under 18 U.S.C. 1001 or other applicable provisions of law, any person who makes a false or fraudulent statement in connection with participation of a DBE in any DOT-assisted program or otherwise violates applicable Federal statutes.
- b. Pursuant to 49 CFR Part 26.109, the rules governing information, confidentiality, cooperation, and intimidation or retaliation are as follows:
 - (1) Availability of records.
 - (i) In responding to requests for information concerning any aspect of the DBE Program, FHWA complies with provisions of the Federal Freedom of Information and Privacy Acts (5 U.S.C. 552 and 552a). FHWA may make available to the public any information concerning the DBE Program release of which is not prohibited by Federal law.
 - (ii) MassDOT shall safeguard from disclosure to unauthorized persons information that may reasonably be considered as confidential business information, consistent with Federal and Massachusetts General Law (M.G.L. c. 66, § 10, M.G.L. c. 4, §7 (26), 950 CMR 32.00).
 - (2) Confidentiality of information on complainants. Notwithstanding the provisions of subparagraph b.(1) of this section, the identity of complainants shall be kept confidential, at their election. If such confidentiality will hinder the investigation, proceeding or hearing, or result in a denial of appropriate administrative due process to other parties, the complainant must be advised for the purpose of waiving the privilege. Complainants are advised that, in some circumstances, failure to waive the privilege may result in the closure of the investigation or dismissal of the proceeding or hearing.

- (3) Cooperation. All participants in FHWA's DBE Program (including, but not limited to, recipients, DBE firms and applicants for DBE certification, complainants and appellants, and Contractors using DBE firms to meet Contract participation goals) are required to cooperate fully and promptly with U.S. DOT and recipient compliance reviews, certification reviews, investigations, and other requests for information. Failure to do so shall be a ground for appropriate action against the party involved (e.g., with respect to recipients, a finding of noncompliance; with respect to DBE firms, denial of certification or removal of eligibility and/or suspension and debarment; with respect to a complainant or appellant, dismissal of the complaint or appeal; with respect to a Contractor which uses DBE firms to meet participation goals, findings of non-responsibility for future Contracts and/or suspension and debarment).
- (4) Intimidation and retaliation. No recipient, Contractor, or any other participant in the program, may intimidate, threaten, coerce, or discriminate against any individual or firm for the purpose of interfering with any right or privilege secured by this part or because the individual or firm has made a complaint, testified, assisted, or participated in any manner in an investigation, proceeding, or hearing under this part. If any recipient or contractor violates this prohibition, that entity is in noncompliance with this 49 CFR Part 26.

11. LIST OF ADDITIONAL DOCUMENTS.

- a. The following documents shall be completed and signed by the bidder and designated DBEs in accordance with Section 7 - Award Documentation and Procedures. These documents must be returned by the bidder to MassDOT's Bid Document Distribution Center:
- Schedule of DBE Participation (Document B00853)
 - Letter of Intent (Document B00854)
 - DBE Joint Check Arrangement Approval Form (Document B00855), if Contractor and DBE plan, or if DBE is required to use a Joint Check
- b. The following document shall be signed and returned by Contractor and Subcontractors/DBEs to the MassDOT District Office overseeing the Project, as applicable:
- Contractor/Subcontractor Certification Form (Document No. 00859) (a checklist of other documents to be included with every subcontract (DBEs and non-DBEs alike)).
- c. The following document shall be provided to MassDOT's Office of Civil Rights and Prequalification Office at least fourteen (14) business days before the bid opening date, if applicable:
- Affidavit of DBE/Non-DBE Joint Venture (Document B00856)
- d. The following document shall be provided to MassDOT's District Office of Civil Rights within 30 calendar days after the work of the DBE is completed, or no later than 30 calendar days after the work of the DBE is on a completed and processed CQE. This document shall be completed and submitted by the Prime Contractor:
- Certificate of Completion by a Minority/Women or Disadvantaged Business Enterprise (M/W/DBE) (Form No. CSD-100)

**REQUIRED CONTRACT PROVISIONS
FEDERAL-AID CONSTRUCTION CONTRACTS**

- I. General
- II. Nondiscrimination
- III. Non-segregated Facilities
- IV. Davis-Bacon and Related Act Provisions
- V. Contract Work Hours and Safety Standards Act Provisions
- VI. Subletting or Assigning the Contract
- VII. Safety: Accident Prevention
- VIII. False Statements Concerning Highway Projects
- IX. Implementation of Clean Air Act and Federal Water Pollution Control Act
- X. Certification Regarding Debarment, Suspension, Ineligibility and Voluntary Exclusion
- XI. Certification Regarding Use of Contract Funds for Lobbying
- XII. Use of United States-Flag Vessels:

ATTACHMENTS

A. Employment and Materials Preference for Appalachian Development Highway System or Appalachian Local Access Road Contracts (included in Appalachian contracts only)

I. GENERAL

1. Form FHWA-1273 must be physically incorporated in each construction contract funded under title 23, United States Code, as required in 23 CFR 633.102(b) (excluding emergency contracts solely intended for debris removal). The contractor (or subcontractor) must insert this form in each subcontract and further require its inclusion in all lower tier subcontracts (excluding purchase orders, rental agreements and other agreements for supplies or services). 23 CFR 633.102(e).

The applicable requirements of Form FHWA-1273 are incorporated by reference for work done under any purchase order, rental agreement or agreement for other services. The prime contractor shall be responsible for compliance by any subcontractor, lower-tier subcontractor or service provider. 23 CFR 633.102(e).

Form FHWA-1273 must be included in all Federal-aid design-build contracts, in all subcontracts and in lower tier subcontracts (excluding subcontracts for design services, purchase orders, rental agreements and other agreements for supplies or services) in accordance with 23 CFR 633.102. The design-builder shall be responsible for compliance by any subcontractor, lower-tier subcontractor or service provider.

Contracting agencies may reference Form FHWA-1273 in solicitation-for-bids or request-for-proposals documents, however, the Form FHWA-1273 must be physically incorporated (not referenced) in all contracts, subcontracts and lower-tier subcontracts (excluding purchase orders, rental agreements and other agreements for supplies or services related to a construction contract). 23 CFR 633.102(b).

2. Subject to the applicability criteria noted in the following sections, these contract provisions shall apply to all work

performed on the contract by the contractor's own organization and with the assistance of workers under the contractor's immediate superintendence and to all work performed on the contract by piecework, station work, or by subcontract. 23 CFR 633.102(d).

3. A breach of any of the stipulations contained in these Required Contract Provisions may be sufficient grounds for withholding of progress payments, withholding of final payment, termination of the contract, suspension / debarment or any other action determined to be appropriate by the contracting agency and FHWA.

4. Selection of Labor: During the performance of this contract, the contractor shall not use convict labor for any purpose within the limits of a construction project on a Federal-aid highway unless it is labor performed by convicts who are on parole, supervised release, or probation. 23 U.S.C. 114(b). The term Federal-aid highway does not include roadways functionally classified as local roads or rural minor collectors. 23 U.S.C. 101(a).

II. NONDISCRIMINATION (23 CFR 230.107(a); 23 CFR Part 230, Subpart A, Appendix A; EO 11246)

The provisions of this section related to 23 CFR Part 230, Subpart A, Appendix A are applicable to all Federal-aid construction contracts and to all related construction subcontracts of \$10,000 or more. The provisions of 23 CFR Part 230 are not applicable to material supply, engineering, or architectural service contracts.

In addition, the contractor and all subcontractors must comply with the following policies: Executive Order 11246, 41 CFR Part 60, 29 CFR Parts 1625-1627, 23 U.S.C. 140, Section 504 of the Rehabilitation Act of 1973, as amended (29 U.S.C. 794), Title VI of the Civil Rights Act of 1964, as amended (42 U.S.C. 2000d et seq.), and related regulations including 49 CFR Parts 21, 26, and 27; and 23 CFR Parts 200, 230, and 633.

The contractor and all subcontractors must comply with: the requirements of the Equal Opportunity Clause in 41 CFR 60-1.4(b) and, for all construction contracts exceeding \$10,000, the Standard Federal Equal Employment Opportunity Construction Contract Specifications in 41 CFR 60-4.3.

Note: The U.S. Department of Labor has exclusive authority to determine compliance with Executive Order 11246 and the policies of the Secretary of Labor including 41 CFR Part 60, and 29 CFR Parts 1625-1627. The contracting agency and the FHWA have the authority and the responsibility to ensure compliance with 23 U.S.C. 140, Section 504 of the Rehabilitation Act of 1973, as amended (29 U.S.C. 794), and Title VI of the Civil Rights Act of 1964, as amended (42 U.S.C. 2000d et seq.), and related regulations including 49 CFR Parts 21, 26, and 27; and 23 CFR Parts 200, 230, and 633.

The following provision is adopted from 23 CFR Part 230, Subpart A, Appendix A, with appropriate revisions to conform to the U.S. Department of Labor (US DOL) and FHWA requirements.

1. Equal Employment Opportunity: Equal Employment Opportunity (EEO) requirements not to discriminate and to take affirmative action to assure equal opportunity as set forth under laws, executive orders, rules, regulations (see 28 CFR Part 35, 29 CFR Part 1630, 29 CFR Parts 1625-1627, 41 CFR Part 60 and 49 CFR Part 27) and orders of the Secretary of Labor as modified by the provisions prescribed herein, and imposed pursuant to 23 U.S.C. 140, shall constitute the EEO and specific affirmative action standards for the contractor's project activities under this contract. The provisions of the Americans with Disabilities Act of 1990 (42 U.S.C. 12101 et seq.) set forth under 28 CFR Part 35 and 29 CFR Part 1630 are incorporated by reference in this contract. In the execution of this contract, the contractor agrees to comply with the following minimum specific requirement activities of EEO:

a. The contractor will work with the contracting agency and the Federal Government to ensure that it has made every good faith effort to provide equal opportunity with respect to all of its terms and conditions of employment and in their review of activities under the contract. 23 CFR 230.409 (g)(4) & (5).

b. The contractor will accept as its operating policy the following statement:

"It is the policy of this Company to assure that applicants are employed, and that employees are treated during employment, without regard to their race, religion, sex, sexual orientation, gender identity, color, national origin, age or disability. Such action shall include: employment, upgrading, demotion, or transfer; recruitment or recruitment advertising; layoff or termination; rates of pay or other forms of compensation; and selection for training, including apprenticeship, pre-apprenticeship, and/or on-the-job training."

2. EEO Officer: The contractor will designate and make known to the contracting officers an EEO Officer who will have the responsibility for and must be capable of effectively administering and promoting an active EEO program and who must be assigned adequate authority and responsibility to do so.

3. Dissemination of Policy: All members of the contractor's staff who are authorized to hire, supervise, promote, and discharge employees, or who recommend such action or are substantially involved in such action, will be made fully cognizant of and will implement the contractor's EEO policy and contractual responsibilities to provide EEO in each grade and classification of employment. To ensure that the above agreement will be met, the following actions will be taken as a minimum:

a. Periodic meetings of supervisory and personnel office employees will be conducted before the start of work and then not less often than once every six months, at which time the contractor's EEO policy and its implementation will be reviewed and explained. The meetings will be conducted by the EEO Officer or other knowledgeable company official.

b. All new supervisory or personnel office employees will be given a thorough indoctrination by the EEO Officer, covering all major aspects of the contractor's EEO obligations within thirty days following their reporting for duty with the contractor.

c. All personnel who are engaged in direct recruitment for the project will be instructed by the EEO Officer in the contractor's procedures for locating and hiring minorities and women.

d. Notices and posters setting forth the contractor's EEO policy will be placed in areas readily accessible to employees, applicants for employment and potential employees.

e. The contractor's EEO policy and the procedures to implement such policy will be brought to the attention of employees by means of meetings, employee handbooks, or other appropriate means.

4. Recruitment: When advertising for employees, the contractor will include in all advertisements for employees the notation: "An Equal Opportunity Employer." All such advertisements will be placed in publications having a large circulation among minorities and women in the area from which the project work force would normally be derived.

a. The contractor will, unless precluded by a valid bargaining agreement, conduct systematic and direct recruitment through public and private employee referral sources likely to yield qualified minorities and women. To meet this requirement, the contractor will identify sources of potential minority group employees and establish with such identified sources procedures whereby minority and women applicants may be referred to the contractor for employment consideration.

b. In the event the contractor has a valid bargaining agreement providing for exclusive hiring hall referrals, the contractor is expected to observe the provisions of that agreement to the extent that the system meets the contractor's compliance with EEO contract provisions. Where implementation of such an agreement has the effect of discriminating against minorities or women, or obligates the contractor to do the same, such implementation violates Federal nondiscrimination provisions.

c. The contractor will encourage its present employees to refer minorities and women as applicants for employment. Information and procedures with regard to referring such applicants will be discussed with employees.

5. Personnel Actions: Wages, working conditions, and employee benefits shall be established and administered, and personnel actions of every type, including hiring, upgrading, promotion, transfer, demotion, layoff, and termination, shall be taken without regard to race, color, religion, sex, sexual orientation, gender identity, national origin, age or disability. The following procedures shall be followed:

a. The contractor will conduct periodic inspections of project sites to ensure that working conditions and employee facilities do not indicate discriminatory treatment of project site personnel.

b. The contractor will periodically evaluate the spread of wages paid within each classification to determine any evidence of discriminatory wage practices.

c. The contractor will periodically review selected personnel actions in depth to determine whether there is evidence of discrimination. Where evidence is found, the contractor will promptly take corrective action. If the review indicates that the discrimination may extend beyond the actions reviewed, such corrective action shall include all affected persons.

d. The contractor will promptly investigate all complaints of alleged discrimination made to the contractor in connection with its obligations under this contract, will attempt to resolve such complaints, and will take appropriate corrective action

within a reasonable time. If the investigation indicates that the discrimination may affect persons other than the complainant, such corrective action shall include such other persons. Upon completion of each investigation, the contractor will inform every complainant of all of their avenues of appeal.

6. Training and Promotion:

a. The contractor will assist in locating, qualifying, and increasing the skills of minorities and women who are applicants for employment or current employees. Such efforts should be aimed at developing full journey level status employees in the type of trade or job classification involved.

b. Consistent with the contractor's work force requirements and as permissible under Federal and State regulations, the contractor shall make full use of training programs (i.e., apprenticeship and on-the-job training programs for the geographical area of contract performance). In the event a special provision for training is provided under this contract, this subparagraph will be superseded as indicated in the special provision. The contracting agency may reserve training positions for persons who receive welfare assistance in accordance with 23 U.S.C. 140(a).

c. The contractor will advise employees and applicants for employment of available training programs and entrance requirements for each.

d. The contractor will periodically review the training and promotion potential of employees who are minorities and women and will encourage eligible employees to apply for such training and promotion.

7. Unions: If the contractor relies in whole or in part upon unions as a source of employees, the contractor will use good faith efforts to obtain the cooperation of such unions to increase opportunities for minorities and women. 23 CFR 230.409. Actions by the contractor, either directly or through a contractor's association acting as agent, will include the procedures set forth below:

a. The contractor will use good faith efforts to develop, in cooperation with the unions, joint training programs aimed toward qualifying more minorities and women for membership in the unions and increasing the skills of minorities and women so that they may qualify for higher paying employment.

b. The contractor will use good faith efforts to incorporate an EEO clause into each union agreement to the end that such union will be contractually bound to refer applicants without regard to their race, color, religion, sex, sexual orientation, gender identity, national origin, age, or disability.

c. The contractor is to obtain information as to the referral practices and policies of the labor union except that to the extent such information is within the exclusive possession of the labor union and such labor union refuses to furnish such information to the contractor, the contractor shall so certify to the contracting agency and shall set forth what efforts have been made to obtain such information.

d. In the event the union is unable to provide the contractor with a reasonable flow of referrals within the time limit set forth in the collective bargaining agreement, the contractor will, through independent recruitment efforts, fill the employment vacancies without regard to race, color, religion, sex, sexual orientation, gender identity, national origin, age, or disability; making full efforts to obtain qualified and/or qualifiable minorities and women. The failure of a union to provide

sufficient referrals (even though it is obligated to provide exclusive referrals under the terms of a collective bargaining agreement) does not relieve the contractor from the requirements of this paragraph. In the event the union referral practice prevents the contractor from meeting the obligations pursuant to Executive Order 11246, as amended, and these special provisions, such contractor shall immediately notify the contracting agency.

8. Reasonable Accommodation for Applicants / Employees with Disabilities: The contractor must be familiar with the requirements for and comply with the Americans with Disabilities Act and all rules and regulations established thereunder. Employers must provide reasonable accommodation in all employment activities unless to do so would cause an undue hardship.

9. Selection of Subcontractors, Procurement of Materials and Leasing of Equipment: The contractor shall not discriminate on the grounds of race, color, religion, sex, sexual orientation, gender identity, national origin, age, or disability in the selection and retention of subcontractors, including procurement of materials and leases of equipment. The contractor shall take all necessary and reasonable steps to ensure nondiscrimination in the administration of this contract.

a. The contractor shall notify all potential subcontractors, suppliers, and lessors of their EEO obligations under this contract.

b. The contractor will use good faith efforts to ensure subcontractor compliance with their EEO obligations.

10. Assurances Required:

a. The requirements of 49 CFR Part 26 and the State DOT's FHWA-approved Disadvantaged Business Enterprise (DBE) program are incorporated by reference.

b. The contractor, subrecipient or subcontractor shall not discriminate on the basis of race, color, national origin, or sex in the performance of this contract. The contractor shall carry out applicable requirements of 49 CFR part 26 in the award and administration of DOT-assisted contracts. Failure by the contractor to carry out these requirements is a material breach of this contract, which may result in the termination of this contract or such other remedy as the recipient deems appropriate, which may include, but is not limited to:

- (1) Withholding monthly progress payments;
- (2) Assessing sanctions;
- (3) Liquidated damages; and/or
- (4) Disqualifying the contractor from future bidding as non-responsible.

c. The Title VI and nondiscrimination provisions of U.S. DOT Order 1050.2A at Appendixes A and E are incorporated by reference. 49 CFR Part 21.

11. Records and Reports: The contractor shall keep such records as necessary to document compliance with the EEO requirements. Such records shall be retained for a period of three years following the date of the final payment to the contractor for all contract work and shall be available at reasonable times and places for inspection by authorized representatives of the contracting agency and the FHWA.

a. The records kept by the contractor shall document the following:

(1) The number and work hours of minority and non-minority group members and women employed in each work classification on the project;

(2) The progress and efforts being made in cooperation with unions, when applicable, to increase employment opportunities for minorities and women; and

(3) The progress and efforts being made in locating, hiring, training, qualifying, and upgrading minorities and women.

b. The contractors and subcontractors will submit an annual report to the contracting agency each July for the duration of the project indicating the number of minority, women, and non-minority group employees currently engaged in each work classification required by the contract work. This information is to be reported on [Form FHWA-1391](#). The staffing data should represent the project work force on board in all or any part of the last payroll period preceding the end of July. If on-the-job training is being required by special provision, the contractor will be required to collect and report training data. The employment data should reflect the work force on board during all or any part of the last payroll period preceding the end of July.

III. NONSEGREGATED FACILITIES

This provision is applicable to all Federal-aid construction contracts and to all related construction subcontracts of more than \$10,000. 41 CFR 60-1.5.

As prescribed by 41 CFR 60-1.8, the contractor must ensure that facilities provided for employees are provided in such a manner that segregation on the basis of race, color, religion, sex, sexual orientation, gender identity, or national origin cannot result. The contractor may neither require such segregated use by written or oral policies nor tolerate such use by employee custom. The contractor's obligation extends further to ensure that its employees are not assigned to perform their services at any location under the contractor's control where the facilities are segregated. The term "facilities" includes waiting rooms, work areas, restaurants and other eating areas, time clocks, restrooms, washrooms, locker rooms and other storage or dressing areas, parking lots, drinking fountains, recreation or entertainment areas, transportation, and housing provided for employees. The contractor shall provide separate or single-user restrooms and necessary dressing or sleeping areas to assure privacy between sexes.

IV. DAVIS-BACON AND RELATED ACT PROVISIONS

This section is applicable to all Federal-aid construction projects exceeding \$2,000 and to all related subcontracts and lower-tier subcontracts (regardless of subcontract size), in accordance with 29 CFR 5.5. The requirements apply to all projects located within the right-of-way of a roadway that is functionally classified as Federal-aid highway. 23 U.S.C. 113. This excludes roadways functionally classified as local roads or rural minor collectors, which are exempt. 23 U.S.C. 101. Where applicable law requires that projects be treated as a project on a Federal-aid highway, the provisions of this subpart will apply regardless of the location of the project. Examples include: Surface Transportation Block Grant Program projects funded under 23 U.S.C. 133 [excluding recreational trails projects], the Nationally Significant Freight and Highway

Projects funded under 23 U.S.C. 117, and National Highway Freight Program projects funded under 23 U.S.C. 167.

The following provisions are from the U.S. Department of Labor regulations in 29 CFR 5.5 "Contract provisions and related matters" with minor revisions to conform to the FHWA-1273 format and FHWA program requirements.

1. Minimum wages (29 CFR 5.5)

a. *Wage rates and fringe benefits.* All laborers and mechanics employed or working upon the site of the work (or otherwise working in construction or development of the project under a development statute), will be paid unconditionally and not less often than once a week, and without subsequent deduction or rebate on any account (except such payroll deductions as are permitted by regulations issued by the Secretary of Labor under the Copeland Act ([29 CFR part 3](#))), the full amount of basic hourly wages and bona fide fringe benefits (or cash equivalents thereof) due at time of payment computed at rates not less than those contained in the wage determination of the Secretary of Labor which is attached hereto and made a part hereof, regardless of any contractual relationship which may be alleged to exist between the contractor and such laborers and mechanics. As provided in paragraphs (d) and (e) of 29 CFR 5.5, the appropriate wage determinations are effective by operation of law even if they have not been attached to the contract. Contributions made or costs reasonably anticipated for bona fide fringe benefits under the Davis-Bacon Act ([40 U.S.C. 3141\(2\)\(B\)](#)) on behalf of laborers or mechanics are considered wages paid to such laborers or mechanics, subject to the provisions of paragraph 1.e. of this section; also, regular contributions made or costs incurred for more than a weekly period (but not less often than quarterly) under plans, funds, or programs which cover the particular weekly period, are deemed to be constructively made or incurred during such weekly period. Such laborers and mechanics must be paid the appropriate wage rate and fringe benefits on the wage determination for the classification(s) of work actually performed, without regard to skill, except as provided in paragraph 4. of this section. Laborers or mechanics performing work in more than one classification may be compensated at the rate specified for each classification for the time actually worked therein: *Provided*, That the employer's payroll records accurately set forth the time spent in each classification in which work is performed. The wage determination (including any additional classifications and wage rates conformed under paragraph 1.c. of this section) and the Davis-Bacon poster (WH-1321) must be posted at all times by the contractor and its subcontractors at the site of the work in a prominent and accessible place where it can be easily seen by the workers.

b. *Frequently recurring classifications.* (1) In addition to wage and fringe benefit rates that have been determined to be prevailing under the procedures set forth in [29 CFR part 1](#), a wage determination may contain, pursuant to § 1.3(f), wage and fringe benefit rates for classifications of laborers and mechanics for which conformance requests are regularly submitted pursuant to paragraph 1.c. of this section, provided that:

(i) The work performed by the classification is not performed by a classification in the wage determination for which a prevailing wage rate has been determined;

(ii) The classification is used in the area by the construction industry; and

(iii) The wage rate for the classification bears a reasonable relationship to the prevailing wage rates contained in the wage determination.

(2) The Administrator will establish wage rates for such classifications in accordance with paragraph 1.c.(1)(iii) of this section. Work performed in such a classification must be paid at no less than the wage and fringe benefit rate listed on the wage determination for such classification.

c. *Conformance.* (1) The contracting officer must require that any class of laborers or mechanics, including helpers, which is not listed in the wage determination and which is to be employed under the contract be classified in conformance with the wage determination. Conformance of an additional classification and wage rate and fringe benefits is appropriate only when the following criteria have been met:

(i) The work to be performed by the classification requested is not performed by a classification in the wage determination; and

(ii) The classification is used in the area by the construction industry; and

(iii) The proposed wage rate, including any bona fide fringe benefits, bears a reasonable relationship to the wage rates contained in the wage determination.

(2) The conformance process may not be used to split, subdivide, or otherwise avoid application of classifications listed in the wage determination.

(3) If the contractor and the laborers and mechanics to be employed in the classification (if known), or their representatives, and the contracting officer agree on the classification and wage rate (including the amount designated for fringe benefits where appropriate), a report of the action taken will be sent by the contracting officer by email to DBAconformance@dol.gov. The Administrator, or an authorized representative, will approve, modify, or disapprove every additional classification action within 30 days of receipt and so advise the contracting officer or will notify the contracting officer within the 30-day period that additional time is necessary.

(4) In the event the contractor, the laborers or mechanics to be employed in the classification or their representatives, and the contracting officer do not agree on the proposed classification and wage rate (including the amount designated for fringe benefits, where appropriate), the contracting officer will, by email to DBAconformance@dol.gov, refer the questions, including the views of all interested parties and the recommendation of the contracting officer, to the Administrator for determination. The Administrator, or an authorized representative, will issue a determination within 30 days of receipt and so advise the contracting officer or will notify the contracting officer within the 30-day period that additional time is necessary.

(5) The contracting officer must promptly notify the contractor of the action taken by the Wage and Hour Division

under paragraphs 1.c.(3) and (4) of this section. The contractor must furnish a written copy of such determination to each affected worker or it must be posted as a part of the wage determination. The wage rate (including fringe benefits where appropriate) determined pursuant to paragraph 1.c.(3) or (4) of this section must be paid to all workers performing work in the classification under this contract from the first day on which work is performed in the classification.

d. *Fringe benefits not expressed as an hourly rate.* Whenever the minimum wage rate prescribed in the contract for a class of laborers or mechanics includes a fringe benefit which is not expressed as an hourly rate, the contractor may either pay the benefit as stated in the wage determination or may pay another bona fide fringe benefit or an hourly cash equivalent thereof.

e. *Unfunded plans.* If the contractor does not make payments to a trustee or other third person, the contractor may consider as part of the wages of any laborer or mechanic the amount of any costs reasonably anticipated in providing bona fide fringe benefits under a plan or program, *Provided*, That the Secretary of Labor has found, upon the written request of the contractor, in accordance with the criteria set forth in § 5.28, that the applicable standards of the Davis-Bacon Act have been met. The Secretary of Labor may require the contractor to set aside in a separate account assets for the meeting of obligations under the plan or program.

f. *Interest.* In the event of a failure to pay all or part of the wages required by the contract, the contractor will be required to pay interest on any underpayment of wages.

2. Withholding (29 CFR 5.5)

a. *Withholding requirements.* The contracting agency may, upon its own action, or must, upon written request of an authorized representative of the Department of Labor, withhold or cause to be withheld from the contractor so much of the accrued payments or advances as may be considered necessary to satisfy the liabilities of the prime contractor or any subcontractor for the full amount of wages and monetary relief, including interest, required by the clauses set forth in this section for violations of this contract, or to satisfy any such liabilities required by any other Federal contract, or federally assisted contract subject to Davis-Bacon labor standards, that is held by the same prime contractor (as defined in § 5.2). The necessary funds may be withheld from the contractor under this contract, any other Federal contract with the same prime contractor, or any other federally assisted contract that is subject to Davis-Bacon labor standards requirements and is held by the same prime contractor, regardless of whether the other contract was awarded or assisted by the same agency, and such funds may be used to satisfy the contractor liability for which the funds were withheld. In the event of a contractor's failure to pay any laborer or mechanic, including any apprentice or helper working on the site of the work all or part of the wages required by the contract, or upon the contractor's failure to submit the required records as discussed in paragraph 3.d. of this section, the contracting agency may on its own initiative and after written notice to the contractor, take such action as may be necessary to cause the suspension of any further payment, advance, or guarantee of funds until such violations have ceased.

b. *Priority to withheld funds.* The Department has priority to funds withheld or to be withheld in accordance with paragraph

2.a. of this section or Section V, paragraph 3.a., or both, over claims to those funds by:

- (1) A contractor's surety(ies), including without limitation performance bond sureties and payment bond sureties;
- (2) A contracting agency for its procurement costs;
- (3) A trustee(s) (either a court-appointed trustee or a U.S. trustee, or both) in bankruptcy of a contractor, or a contractor's bankruptcy estate;
- (4) A contractor's assignee(s);
- (5) A contractor's successor(s); or
- (6) A claim asserted under the Prompt Payment Act, [31 U.S.C. 3901–3907](#).

3. Records and certified payrolls (29 CFR 5.5)

a. Basic record requirements (1) Length of record retention. All regular payrolls and other basic records must be maintained by the contractor and any subcontractor during the course of the work and preserved for all laborers and mechanics working at the site of the work (or otherwise working in construction or development of the project under a development statute) for a period of at least 3 years after all the work on the prime contract is completed.

(2) Information required. Such records must contain the name; Social Security number; last known address, telephone number, and email address of each such worker; each worker's correct classification(s) of work actually performed; hourly rates of wages paid (including rates of contributions or costs anticipated for bona fide fringe benefits or cash equivalents thereof of the types described in [40 U.S.C. 3141\(2\)\(B\)](#) of the Davis-Bacon Act); daily and weekly number of hours actually worked in total and on each covered contract; deductions made; and actual wages paid.

(3) Additional records relating to fringe benefits. Whenever the Secretary of Labor has found under paragraph 1.e. of this section that the wages of any laborer or mechanic include the amount of any costs reasonably anticipated in providing benefits under a plan or program described in [40 U.S.C. 3141\(2\)\(B\)](#) of the Davis-Bacon Act, the contractor must maintain records which show that the commitment to provide such benefits is enforceable, that the plan or program is financially responsible, and that the plan or program has been communicated in writing to the laborers or mechanics affected, and records which show the costs anticipated or the actual cost incurred in providing such benefits.

(4) Additional records relating to apprenticeship. Contractors with apprentices working under approved programs must maintain written evidence of the registration of apprenticeship programs, the registration of the apprentices, and the ratios and wage rates prescribed in the applicable programs.

b. Certified payroll requirements (1) Frequency and method of submission. The contractor or subcontractor must submit weekly, for each week in which any DBA- or Related Acts-covered work is performed, certified payrolls to the contracting

agency. The prime contractor is responsible for the submission of all certified payrolls by all subcontractors. A contracting agency or prime contractor may permit or require contractors to submit certified payrolls through an electronic system, as long as the electronic system requires a legally valid electronic signature; the system allows the contractor, the contracting agency, and the Department of Labor to access the certified payrolls upon request for at least 3 years after the work on the prime contract has been completed; and the contracting agency or prime contractor permits other methods of submission in situations where the contractor is unable or limited in its ability to use or access the electronic system.

(2) Information required. The certified payrolls submitted must set out accurately and completely all of the information required to be maintained under paragraph 3.a.(2) of this section, except that full Social Security numbers and last known addresses, telephone numbers, and email addresses must not be included on weekly transmittals. Instead, the certified payrolls need only include an individually identifying number for each worker (e.g., the last four digits of the worker's Social Security number). The required weekly certified payroll information may be submitted using Optional Form WH-347 or in any other format desired. Optional Form WH-347 is available for this purpose from the Wage and Hour Division website at <https://www.dol.gov/sites/dolgov/files/WHD/legacy/files/wh347.pdf> or its successor website. It is not a violation of this section for a prime contractor to require a subcontractor to provide full Social Security numbers and last known addresses, telephone numbers, and email addresses to the prime contractor for its own records, without weekly submission by the subcontractor to the contracting agency.

(3) Statement of Compliance. Each certified payroll submitted must be accompanied by a "Statement of Compliance," signed by the contractor or subcontractor, or the contractor's or subcontractor's agent who pays or supervises the payment of the persons working on the contract, and must certify the following:

(i) That the certified payroll for the payroll period contains the information required to be provided under paragraph 3.b. of this section, the appropriate information and basic records are being maintained under paragraph 3.a. of this section, and such information and records are correct and complete;

(ii) That each laborer or mechanic (including each helper and apprentice) working on the contract during the payroll period has been paid the full weekly wages earned, without rebate, either directly or indirectly, and that no deductions have been made either directly or indirectly from the full wages earned, other than permissible deductions as set forth in [29 CFR part 3](#); and

(iii) That each laborer or mechanic has been paid not less than the applicable wage rates and fringe benefits or cash equivalents for the classification(s) of work actually performed, as specified in the applicable wage determination incorporated into the contract.

(4) Use of Optional Form WH-347. The weekly submission of a properly executed certification set forth on the reverse side of Optional Form WH-347 will satisfy the requirement for submission of the "Statement of Compliance" required by paragraph 3.b.(3) of this section.

(5) *Signature.* The signature by the contractor, subcontractor, or the contractor's or subcontractor's agent must be an original handwritten signature or a legally valid electronic signature.

(6) *Falsification.* The falsification of any of the above certifications may subject the contractor or subcontractor to civil or criminal prosecution under [18 U.S.C. 1001](#) and [31 U.S.C. 3729](#).

(7) *Length of certified payroll retention.* The contractor or subcontractor must preserve all certified payrolls during the course of the work and for a period of 3 years after all the work on the prime contract is completed.

c. *Contracts, subcontracts, and related documents.* The contractor or subcontractor must maintain this contract or subcontract and related documents including, without limitation, bids, proposals, amendments, modifications, and extensions. The contractor or subcontractor must preserve these contracts, subcontracts, and related documents during the course of the work and for a period of 3 years after all the work on the prime contract is completed.

d. *Required disclosures and access (1) Required record disclosures and access to workers.* The contractor or subcontractor must make the records required under paragraphs 3.a. through 3.c. of this section, and any other documents that the contracting agency, the State DOT, the FHWA, or the Department of Labor deems necessary to determine compliance with the labor standards provisions of any of the applicable statutes referenced by § 5.1, available for inspection, copying, or transcription by authorized representatives of the contracting agency, the State DOT, the FHWA, or the Department of Labor, and must permit such representatives to interview workers during working hours on the job.

(2) *Sanctions for non-compliance with records and worker access requirements.* If the contractor or subcontractor fails to submit the required records or to make them available, or refuses to permit worker interviews during working hours on the job, the Federal agency may, after written notice to the contractor, sponsor, applicant, owner, or other entity, as the case may be, that maintains such records or that employs such workers, take such action as may be necessary to cause the suspension of any further payment, advance, or guarantee of funds. Furthermore, failure to submit the required records upon request or to make such records available, or to permit worker interviews during working hours on the job, may be grounds for debarment action pursuant to § 5.12. In addition, any contractor or other person that fails to submit the required records or make those records available to WHD within the time WHD requests that the records be produced will be precluded from introducing as evidence in an administrative proceeding under [29 CFR part 6](#) any of the required records that were not provided or made available to WHD. WHD will take into consideration a reasonable request from the contractor or person for an extension of the time for submission of records. WHD will determine the reasonableness of the request and may consider, among other things, the location of the records and the volume of production.

(3) *Required information disclosures.* Contractors and subcontractors must maintain the full Social Security number and last known address, telephone number, and email address

of each covered worker, and must provide them upon request to the contracting agency, the State DOT, the FHWA, the contractor, or the Wage and Hour Division of the Department of Labor for purposes of an investigation or other compliance action.

4. Apprentices and equal employment opportunity (29 CFR 5.5)

a. *Apprentices (1) Rate of pay.* Apprentices will be permitted to work at less than the predetermined rate for the work they perform when they are employed pursuant to and individually registered in a bona fide apprenticeship program registered with the U.S. Department of Labor, Employment and Training Administration, Office of Apprenticeship (OA), or with a State Apprenticeship Agency recognized by the OA. A person who is not individually registered in the program, but who has been certified by the OA or a State Apprenticeship Agency (where appropriate) to be eligible for probationary employment as an apprentice, will be permitted to work at less than the predetermined rate for the work they perform in the first 90 days of probationary employment as an apprentice in such a program. In the event the OA or a State Apprenticeship Agency recognized by the OA withdraws approval of an apprenticeship program, the contractor will no longer be permitted to use apprentices at less than the applicable predetermined rate for the work performed until an acceptable program is approved.

(2) *Fringe benefits.* Apprentices must be paid fringe benefits in accordance with the provisions of the apprenticeship program. If the apprenticeship program does not specify fringe benefits, apprentices must be paid the full amount of fringe benefits listed on the wage determination for the applicable classification. If the Administrator determines that a different practice prevails for the applicable apprentice classification, fringe benefits must be paid in accordance with that determination.

(3) *Apprenticeship ratio.* The allowable ratio of apprentices to journeyworkers on the job site in any craft classification must not be greater than the ratio permitted to the contractor as to the entire work force under the registered program or the ratio applicable to the locality of the project pursuant to paragraph 4.a.(4) of this section. Any worker listed on a payroll at an apprentice wage rate, who is not registered or otherwise employed as stated in paragraph 4.a.(1) of this section, must be paid not less than the applicable wage rate on the wage determination for the classification of work actually performed. In addition, any apprentice performing work on the job site in excess of the ratio permitted under this section must be paid not less than the applicable wage rate on the wage determination for the work actually performed.

(4) *Reciprocity of ratios and wage rates.* Where a contractor is performing construction on a project in a locality other than the locality in which its program is registered, the ratios and wage rates (expressed in percentages of the journeyworker's hourly rate) applicable within the locality in which the construction is being performed must be observed. If there is no applicable ratio or wage rate for the locality of the project, the ratio and wage rate specified in the contractor's registered program must be observed.

b. *Equal employment opportunity.* The use of apprentices and journeyworkers under this part must be in conformity with

the equal employment opportunity requirements of Executive Order 11246, as amended, and [29 CFR part 30](#).

c. Apprentices and Trainees (programs of the U.S. DOT).

Apprentices and trainees working under apprenticeship and skill training programs which have been certified by the Secretary of Transportation as promoting EEO in connection with Federal-aid highway construction programs are not subject to the requirements of paragraph 4 of this Section IV. 23 CFR 230.111(e)(2). The straight time hourly wage rates for apprentices and trainees under such programs will be established by the particular programs. The ratio of apprentices and trainees to journeyworkers shall not be greater than permitted by the terms of the particular program.

5. Compliance with Copeland Act requirements. The contractor shall comply with the requirements of 29 CFR part 3, which are incorporated by reference in this contract as provided in 29 CFR 5.5.

6. Subcontracts. The contractor or subcontractor must insert FHWA-1273 in any subcontracts, along with the applicable wage determination(s) and such other clauses or contract modifications as the contracting agency may by appropriate instructions require, and a clause requiring the subcontractors to include these clauses and wage determination(s) in any lower tier subcontracts. The prime contractor is responsible for the compliance by any subcontractor or lower tier subcontractor with all the contract clauses in this section. In the event of any violations of these clauses, the prime contractor and any subcontractor(s) responsible will be liable for any unpaid wages and monetary relief, including interest from the date of the underpayment or loss, due to any workers of lower-tier subcontractors, and may be subject to debarment, as appropriate. 29 CFR 5.5.

7. Contract termination: debarment. A breach of the contract clauses in 29 CFR 5.5 may be grounds for termination of the contract, and for debarment as a contractor and a subcontractor as provided in 29 CFR 5.12.

8. Compliance with Davis-Bacon and Related Act requirements. All rulings and interpretations of the Davis-Bacon and Related Acts contained in 29 CFR parts 1, 3, and 5 are herein incorporated by reference in this contract as provided in 29 CFR 5.5.

9. Disputes concerning labor standards. As provided in 29 CFR 5.5, disputes arising out of the labor standards provisions of this contract shall not be subject to the general disputes clause of this contract. Such disputes shall be resolved in accordance with the procedures of the Department of Labor set forth in 29 CFR parts 5, 6, and 7. Disputes within the meaning of this clause include disputes between the contractor (or any of its subcontractors) and the contracting agency, the U.S. Department of Labor, or the employees or their representatives.

10. Certification of eligibility. a. By entering into this contract, the contractor certifies that neither it nor any person or firm who has an interest in the contractor's firm is a person or firm ineligible to be awarded Government contracts by virtue of [40 U.S.C. 3144\(b\)](#) or § 5.12(a).

b. No part of this contract shall be subcontracted to any person or firm ineligible for award of a Government contract by virtue of [40 U.S.C. 3144\(b\)](#) or § 5.12(a).

c. The penalty for making false statements is prescribed in the U.S. Code, Title 18 Crimes and Criminal Procedure, [18 U.S.C. 1001](#).

11. Anti-retaliation. It is unlawful for any person to discharge, demote, intimidate, threaten, restrain, coerce, blacklist, harass, or in any other manner discriminate against, or to cause any person to discharge, demote, intimidate, threaten, restrain, coerce, blacklist, harass, or in any other manner discriminate against, any worker or job applicant for:

a. Notifying any contractor of any conduct which the worker reasonably believes constitutes a violation of the DBA, Related Acts, this part, or [29 CFR part 1](#) or [3](#);

b. Filing any complaint, initiating or causing to be initiated any proceeding, or otherwise asserting or seeking to assert on behalf of themselves or others any right or protection under the DBA, Related Acts, this part, or [29 CFR part 1](#) or [3](#);

c. Cooperating in any investigation or other compliance action, or testifying in any proceeding under the DBA, Related Acts, this part, or [29 CFR part 1](#) or [3](#); or

d. Informing any other person about their rights under the DBA, Related Acts, this part, or [29 CFR part 1](#) or [3](#).

V. CONTRACT WORK HOURS AND SAFETY STANDARDS ACT

Pursuant to 29 CFR 5.5(b), the following clauses apply to any Federal-aid construction contract in an amount in excess of \$100,000 and subject to the overtime provisions of the Contract Work Hours and Safety Standards Act. These clauses shall be inserted in addition to the clauses required by 29 CFR 5.5(a) or 29 CFR 4.6. As used in this paragraph, the terms laborers and mechanics include watchpersons and guards.

1. Overtime requirements. No contractor or subcontractor contracting for any part of the contract work which may require or involve the employment of laborers or mechanics shall require or permit any such laborer or mechanic in any workweek in which he or she is employed on such work to work in excess of forty hours in such workweek unless such laborer or mechanic receives compensation at a rate not less than one and one-half times the basic rate of pay for all hours worked in excess of forty hours in such workweek. 29 CFR 5.5.

2. Violation; liability for unpaid wages; liquidated damages. In the event of any violation of the clause set forth in paragraph 1. of this section the contractor and any subcontractor responsible therefor shall be liable for the unpaid wages and interest from the date of the underpayment. In addition, such contractor and subcontractor shall be liable to the United States (in the case of work done under contract for the District of Columbia or a territory, to such District or to such territory), for liquidated damages. Such liquidated damages shall be computed with respect to each individual laborer or

mechanic, including watchpersons and guards, employed in violation of the clause set forth in paragraph 1. of this section, in the sum currently provided in 29 CFR 5.5(b)(2)* for each calendar day on which such individual was required or permitted to work in excess of the standard workweek of forty hours without payment of the overtime wages required by the clause set forth in paragraph 1. of this section.

* \$31 as of January 15, 2023 (See 88 FR 88 FR 2210) as may be adjusted annually by the Department of Labor, pursuant to the Federal Civil Penalties Inflation Adjustment Act of 1990.

3. Withholding for unpaid wages and liquidated damages

a. *Withholding process.* The FHWA or the contracting agency may, upon its own action, or must, upon written request of an authorized representative of the Department of Labor, withhold or cause to be withheld from the contractor so much of the accrued payments or advances as may be considered necessary to satisfy the liabilities of the prime contractor or any subcontractor for any unpaid wages; monetary relief, including interest; and liquidated damages required by the clauses set forth in this section on this contract, any other Federal contract with the same prime contractor, or any other federally assisted contract subject to the Contract Work Hours and Safety Standards Act that is held by the same prime contractor (as defined in § 5.2). The necessary funds may be withheld from the contractor under this contract, any other Federal contract with the same prime contractor, or any other federally assisted contract that is subject to the Contract Work Hours and Safety Standards Act and is held by the same prime contractor, regardless of whether the other contract was awarded or assisted by the same agency, and such funds may be used to satisfy the contractor liability for which the funds were withheld.

b. *Priority to withheld funds.* The Department has priority to funds withheld or to be withheld in accordance with Section IV paragraph 2.a. or paragraph 3.a. of this section, or both, over claims to those funds by:

- (1) A contractor's surety(ies), including without limitation performance bond sureties and payment bond sureties;
- (2) A contracting agency for its procurement costs;
- (3) A trustee(s) (either a court-appointed trustee or a U.S. trustee, or both) in bankruptcy of a contractor, or a contractor's bankruptcy estate;
- (4) A contractor's assignee(s);
- (5) A contractor's successor(s); or
- (6) A claim asserted under the Prompt Payment Act, [31 U.S.C. 3901](#)–3907.

4. Subcontracts. The contractor or subcontractor must insert in any subcontracts the clauses set forth in paragraphs 1. through 5. of this section and a clause requiring the subcontractors to include these clauses in any lower tier subcontracts. The prime contractor is responsible for compliance by any subcontractor or lower tier subcontractor with the clauses set forth in paragraphs 1. through 5. In the

event of any violations of these clauses, the prime contractor and any subcontractor(s) responsible will be liable for any unpaid wages and monetary relief, including interest from the date of the underpayment or loss, due to any workers of lower-tier subcontractors, and associated liquidated damages and may be subject to debarment, as appropriate.

5. Anti-retaliation. It is unlawful for any person to discharge, demote, intimidate, threaten, restrain, coerce, blacklist, harass, or in any other manner discriminate against, or to cause any person to discharge, demote, intimidate, threaten, restrain, coerce, blacklist, harass, or in any other manner discriminate against, any worker or job applicant for:

- a. Notifying any contractor of any conduct which the worker reasonably believes constitutes a violation of the Contract Work Hours and Safety Standards Act (CWHSSA) or its implementing regulations in this part;
- b. Filing any complaint, initiating or causing to be initiated any proceeding, or otherwise asserting or seeking to assert on behalf of themselves or others any right or protection under CWHSSA or this part;
- c. Cooperating in any investigation or other compliance action, or testifying in any proceeding under CWHSSA or this part; or
- d. Informing any other person about their rights under CWHSSA or this part.

VI. SUBLETTING OR ASSIGNING THE CONTRACT

This provision is applicable to all Federal-aid construction contracts on the National Highway System pursuant to 23 CFR 635.116.

1. The contractor shall perform with its own organization contract work amounting to not less than 30 percent (or a greater percentage if specified elsewhere in the contract) of the total original contract price, excluding any specialty items designated by the contracting agency. Specialty items may be performed by subcontract and the amount of any such specialty items performed may be deducted from the total original contract price before computing the amount of work required to be performed by the contractor's own organization (23 CFR 635.116).

a. The term "perform work with its own organization" in paragraph 1 of Section VI refers to workers employed or leased by the prime contractor, and equipment owned or rented by the prime contractor, with or without operators. Such term does not include employees or equipment of a subcontractor or lower tier subcontractor, agents of the prime contractor, or any other assignees. The term may include payments for the costs of hiring leased employees from an employee leasing firm meeting all relevant Federal and State regulatory requirements. Leased employees may only be included in this term if the prime contractor meets all of the following conditions: (based on longstanding interpretation)

- (1) the prime contractor maintains control over the supervision of the day-to-day activities of the leased employees;
- (2) the prime contractor remains responsible for the quality of the work of the leased employees;

- (3) the prime contractor retains all power to accept or exclude individual employees from work on the project; and
- (4) the prime contractor remains ultimately responsible for the payment of predetermined minimum wages, the submission of payrolls, statements of compliance and all other Federal regulatory requirements.

b. "Specialty Items" shall be construed to be limited to work that requires highly specialized knowledge, abilities, or equipment not ordinarily available in the type of contracting organizations qualified and expected to bid or propose on the contract as a whole and in general are to be limited to minor components of the overall contract. 23 CFR 635.102.

2. Pursuant to 23 CFR 635.116(a), the contract amount upon which the requirements set forth in paragraph (1) of Section VI is computed includes the cost of material and manufactured products which are to be purchased or produced by the contractor under the contract provisions.

3. Pursuant to 23 CFR 635.116(c), the contractor shall furnish (a) a competent superintendent or supervisor who is employed by the firm, has full authority to direct performance of the work in accordance with the contract requirements, and is in charge of all construction operations (regardless of who performs the work) and (b) such other of its own organizational resources (supervision, management, and engineering services) as the contracting officer determines is necessary to assure the performance of the contract.

4. No portion of the contract shall be sublet, assigned or otherwise disposed of except with the written consent of the contracting officer, or authorized representative, and such consent when given shall not be construed to relieve the contractor of any responsibility for the fulfillment of the contract. Written consent will be given only after the contracting agency has assured that each subcontract is evidenced in writing and that it contains all pertinent provisions and requirements of the prime contract. (based on long-standing interpretation of 23 CFR 635.116).

5. The 30-percent self-performance requirement of paragraph (1) is not applicable to design-build contracts; however, contracting agencies may establish their own self-performance requirements. 23 CFR 635.116(d).

VII. SAFETY: ACCIDENT PREVENTION

This provision is applicable to all Federal-aid construction contracts and to all related subcontracts.

1. In the performance of this contract the contractor shall comply with all applicable Federal, State, and local laws governing safety, health, and sanitation (23 CFR Part 635). The contractor shall provide all safeguards, safety devices and protective equipment and take any other needed actions as it determines, or as the contracting officer may determine, to be reasonably necessary to protect the life and health of employees on the job and the safety of the public and to protect property in connection with the performance of the work covered by the contract. 23 CFR 635.108.

2. It is a condition of this contract, and shall be made a condition of each subcontract, which the contractor enters into pursuant to this contract, that the contractor and any subcontractor shall not permit any employee, in performance of the contract, to work in surroundings or under conditions which are unsanitary, hazardous or dangerous to his/her health or safety, as determined under construction safety and

health standards (29 CFR Part 1926) promulgated by the Secretary of Labor, in accordance with Section 107 of the Contract Work Hours and Safety Standards Act (40 U.S.C. 3704). 29 CFR 1926.10.

3. Pursuant to 29 CFR 1926.3, it is a condition of this contract that the Secretary of Labor or authorized representative thereof, shall have right of entry to any site of contract performance to inspect or investigate the matter of compliance with the construction safety and health standards and to carry out the duties of the Secretary under Section 107 of the Contract Work Hours and Safety Standards Act (40 U.S.C. 3704).

VIII. FALSE STATEMENTS CONCERNING HIGHWAY PROJECTS

This provision is applicable to all Federal-aid construction contracts and to all related subcontracts.

In order to assure high quality and durable construction in conformity with approved plans and specifications and a high degree of reliability on statements and representations made by engineers, contractors, suppliers, and workers on Federal-aid highway projects, it is essential that all persons concerned with the project perform their functions as carefully, thoroughly, and honestly as possible. Willful falsification, distortion, or misrepresentation with respect to any facts related to the project is a violation of Federal law. To prevent any misunderstanding regarding the seriousness of these and similar acts, Form FHWA-1022 shall be posted on each Federal-aid highway project (23 CFR Part 635) in one or more places where it is readily available to all persons concerned with the project:

18 U.S.C. 1020 reads as follows:

"Whoever, being an officer, agent, or employee of the United States, or of any State or Territory, or whoever, whether a person, association, firm, or corporation, knowingly makes any false statement, false representation, or false report as to the character, quality, quantity, or cost of the material used or to be used, or the quantity or quality of the work performed or to be performed, or the cost thereof in connection with the submission of plans, maps, specifications, contracts, or costs of construction on any highway or related project submitted for approval to the Secretary of Transportation; or

Whoever knowingly makes any false statement, false representation, false report or false claim with respect to the character, quality, quantity, or cost of any work performed or to be performed, or materials furnished or to be furnished, in connection with the construction of any highway or related project approved by the Secretary of Transportation; or

Whoever knowingly makes any false statement or false representation as to material fact in any statement, certificate, or report submitted pursuant to provisions of the Federal-aid Roads Act approved July 11, 1916, (39 Stat. 355), as amended and supplemented;

Shall be fined under this title or imprisoned not more than 5 years or both."

IX. IMPLEMENTATION OF CLEAN AIR ACT AND FEDERAL WATER POLLUTION CONTROL ACT (42 U.S.C. 7606; 2 CFR 200.88; EO 11738)

This provision is applicable to all Federal-aid construction contracts in excess of \$150,000 and to all related subcontracts. 48 CFR 2.101; 2 CFR 200.327.

By submission of this bid/proposal or the execution of this contract or subcontract, as appropriate, the bidder, proposer, Federal-aid construction contractor, subcontractor, supplier, or vendor agrees to comply with all applicable standards, orders or regulations issued pursuant to the Clean Air Act (42 U.S.C. 7401-7671q) and the Federal Water Pollution Control Act, as amended (33 U.S.C. 1251-1387). Violations must be reported to the Federal Highway Administration and the Regional Office of the Environmental Protection Agency. 2 CFR Part 200, Appendix II.

The contractor agrees to include or cause to be included the requirements of this Section in every subcontract, and further agrees to take such action as the contracting agency may direct as a means of enforcing such requirements. 2 CFR 200.327.

X. CERTIFICATION REGARDING DEBARMENT, SUSPENSION, INELIGIBILITY AND VOLUNTARY EXCLUSION

This provision is applicable to all Federal-aid construction contracts, design-build contracts, subcontracts, lower-tier subcontracts, purchase orders, lease agreements, consultant contracts or any other covered transaction requiring FHWA approval or that is estimated to cost \$25,000 or more – as defined in 2 CFR Parts 180 and 1200. 2 CFR 180.220 and 1200.220.

1. Instructions for Certification – First Tier Participants:

a. By signing and submitting this proposal, the prospective first tier participant is providing the certification set out below.

b. The inability of a person to provide the certification set out below will not necessarily result in denial of participation in this covered transaction. The prospective first tier participant shall submit an explanation of why it cannot provide the certification set out below. The certification or explanation will be considered in connection with the department or agency's determination whether to enter into this transaction. However, failure of the prospective first tier participant to furnish a certification or an explanation shall disqualify such a person from participation in this transaction. 2 CFR 180.320.

c. The certification in this clause is a material representation of fact upon which reliance was placed when the contracting agency determined to enter into this transaction. If it is later determined that the prospective participant knowingly rendered an erroneous certification, in addition to other remedies available to the Federal Government, the contracting agency may terminate this transaction for cause of default. 2 CFR 180.325.

d. The prospective first tier participant shall provide immediate written notice to the contracting agency to whom this proposal is submitted if any time the prospective first tier participant learns that its certification was erroneous when submitted or has become erroneous by reason of changed circumstances. 2 CFR 180.345 and 180.350.

e. The terms "covered transaction," "debarred," "suspended," "ineligible," "participant," "person," "principal," and "voluntarily excluded," as used in this clause, are defined in 2 CFR Parts 180, Subpart I, 180.900-180.1020, and 1200. "First Tier Covered Transactions" refers to any covered transaction between a recipient or subrecipient of Federal funds and a participant (such as the prime or general contract). "Lower Tier Covered Transactions" refers to any covered transaction under a First Tier Covered Transaction (such as subcontracts). "First Tier Participant" refers to the participant who has entered into a covered transaction with a recipient or subrecipient of Federal funds (such as the prime or general contractor). "Lower Tier Participant" refers any participant who has entered into a covered transaction with a First Tier Participant or other Lower Tier Participants (such as subcontractors and suppliers).

f. The prospective first tier participant agrees by submitting this proposal that, should the proposed covered transaction be entered into, it shall not knowingly enter into any lower tier covered transaction with a person who is debarred, suspended, declared ineligible, or voluntarily excluded from participation in this covered transaction, unless authorized by the department or agency entering into this transaction. 2 CFR 180.330.

g. The prospective first tier participant further agrees by submitting this proposal that it will include the clause titled "Certification Regarding Debarment, Suspension, Ineligibility and Voluntary Exclusion-Lower Tier Covered Transactions," provided by the department or contracting agency, entering into this covered transaction, without modification, in all lower tier covered transactions and in all solicitations for lower tier covered transactions exceeding the \$25,000 threshold. 2 CFR 180.220 and 180.300.

h. A participant in a covered transaction may rely upon a certification of a prospective participant in a lower tier covered transaction that is not debarred, suspended, ineligible, or voluntarily excluded from the covered transaction, unless it knows that the certification is erroneous. 2 CFR 180.300; 180.320, and 180.325. A participant is responsible for ensuring that its principals are not suspended, debarred, or otherwise ineligible to participate in covered transactions. 2 CFR 180.335. To verify the eligibility of its principals, as well as the eligibility of any lower tier prospective participants, each participant may, but is not required to, check the System for Award Management website (<https://www.sam.gov/>). 2 CFR 180.300, 180.320, and 180.325.

i. Nothing contained in the foregoing shall be construed to require the establishment of a system of records in order to render in good faith the certification required by this clause. The knowledge and information of the prospective participant is not required to exceed that which is normally possessed by a prudent person in the ordinary course of business dealings.

j. Except for transactions authorized under paragraph (f) of these instructions, if a participant in a covered transaction knowingly enters into a lower tier covered transaction with a person who is suspended, debarred, ineligible, or voluntarily excluded from participation in this transaction, in addition to other remedies available to the Federal Government, the department or agency may terminate this transaction for cause or default. 2 CFR 180.325.

* * * * *

2. Certification Regarding Debarment, Suspension, Ineligibility and Voluntary Exclusion – First Tier Participants:

a. The prospective first tier participant certifies to the best of its knowledge and belief, that it and its principals:

(1) Are not presently debarred, suspended, proposed for debarment, declared ineligible, or voluntarily excluded from participating in covered transactions by any Federal department or agency, 2 CFR 180.335;

(2) Have not within a three-year period preceding this proposal been convicted of or had a civil judgment rendered against them for commission of fraud or a criminal offense in connection with obtaining, attempting to obtain, or performing a public (Federal, State, or local) transaction or contract under a public transaction; violation of Federal or State antitrust statutes or commission of embezzlement, theft, forgery, bribery, falsification or destruction of records, making false statements, or receiving stolen property, 2 CFR 180.800;

(3) Are not presently indicted for or otherwise criminally or civilly charged by a governmental entity (Federal, State or local) with commission of any of the offenses enumerated in paragraph (a)(2) of this certification, 2 CFR 180.700 and 180.800; and

(4) Have not within a three-year period preceding this application/proposal had one or more public transactions (Federal, State or local) terminated for cause or default. 2 CFR 180.335(d).

(5) Are not a corporation that has been convicted of a felony violation under any Federal law within the two-year period preceding this proposal (USDOT Order 4200.6 implementing appropriations act requirements); and

(6) Are not a corporation with any unpaid Federal tax liability that has been assessed, for which all judicial and administrative remedies have been exhausted, or have lapsed, and that is not being paid in a timely manner pursuant to an agreement with the authority responsible for collecting the tax liability (USDOT Order 4200.6 implementing appropriations act requirements).

b. Where the prospective participant is unable to certify to any of the statements in this certification, such prospective participant should attach an explanation to this proposal. 2 CFR 180.335 and 180.340.

3. Instructions for Certification - Lower Tier Participants:

(Applicable to all subcontracts, purchase orders, and other lower tier transactions requiring prior FHWA approval or estimated to cost \$25,000 or more - 2 CFR Parts 180 and 1200). 2 CFR 180.220 and 1200.220.

a. By signing and submitting this proposal, the prospective lower tier participant is providing the certification set out below.

b. The certification in this clause is a material representation of fact upon which reliance was placed when this transaction was entered into. If it is later determined that the prospective lower tier participant knowingly rendered an erroneous certification, in addition to other remedies available to the Federal Government, the department, or agency with which

this transaction originated may pursue available remedies, including suspension and/or debarment.

c. The prospective lower tier participant shall provide immediate written notice to the person to which this proposal is submitted if at any time the prospective lower tier participant learns that its certification was erroneous by reason of changed circumstances. 2 CFR 180.365.

d. The terms "covered transaction," "debarred," "suspended," "ineligible," "participant," "person," "principal," and "voluntarily excluded," as used in this clause, are defined in 2 CFR Parts 180, Subpart I, 180.900 – 180.1020, and 1200. You may contact the person to which this proposal is submitted for assistance in obtaining a copy of those regulations. "First Tier Covered Transactions" refers to any covered transaction between a recipient or subrecipient of Federal funds and a participant (such as the prime or general contract). "Lower Tier Covered Transactions" refers to any covered transaction under a First Tier Covered Transaction (such as subcontracts). "First Tier Participant" refers to the participant who has entered into a covered transaction with a recipient or subrecipient of Federal funds (such as the prime or general contractor). "Lower Tier Participant" refers any participant who has entered into a covered transaction with a First Tier Participant or other Lower Tier Participants (such as subcontractors and suppliers).

e. The prospective lower tier participant agrees by submitting this proposal that, should the proposed covered transaction be entered into, it shall not knowingly enter into any lower tier covered transaction with a person who is debarred, suspended, declared ineligible, or voluntarily excluded from participation in this covered transaction, unless authorized by the department or agency with which this transaction originated. 2 CFR 1200.220 and 1200.332.

f. The prospective lower tier participant further agrees by submitting this proposal that it will include this clause titled "Certification Regarding Debarment, Suspension, Ineligibility and Voluntary Exclusion-Lower Tier Covered Transaction," without modification, in all lower tier covered transactions and in all solicitations for lower tier covered transactions exceeding the \$25,000 threshold. 2 CFR 180.220 and 1200.220.

g. A participant in a covered transaction may rely upon a certification of a prospective participant in a lower tier covered transaction that is not debarred, suspended, ineligible, or voluntarily excluded from the covered transaction, unless it knows that the certification is erroneous. A participant is responsible for ensuring that its principals are not suspended, debarred, or otherwise ineligible to participate in covered transactions. To verify the eligibility of its principals, as well as the eligibility of any lower tier prospective participants, each participant may, but is not required to, check the System for Award Management website (<https://www.sam.gov/>), which is compiled by the General Services Administration. 2 CFR 180.300, 180.320, 180.330, and 180.335.

h. Nothing contained in the foregoing shall be construed to require establishment of a system of records in order to render in good faith the certification required by this clause. The knowledge and information of participant is not required to exceed that which is normally possessed by a prudent person in the ordinary course of business dealings.

i. Except for transactions authorized under paragraph e of these instructions, if a participant in a covered transaction knowingly enters into a lower tier covered transaction with a person who is suspended, debarred, ineligible, or voluntarily

excluded from participation in this transaction, in addition to other remedies available to the Federal Government, the department or agency with which this transaction originated may pursue available remedies, including suspension and/or debarment. 2 CFR 180.325.

4. Certification Regarding Debarment, Suspension, Ineligibility and Voluntary Exclusion--Lower Tier Participants:

a. The prospective lower tier participant certifies, by submission of this proposal, that neither it nor its principals:

(1) is presently debarred, suspended, proposed for debarment, declared ineligible, or voluntarily excluded from participating in covered transactions by any Federal department or agency, 2 CFR 180.355;

(2) is a corporation that has been convicted of a felony violation under any Federal law within the two-year period preceding this proposal (USDOT Order 4200.6 implementing appropriations act requirements); and

(3) is a corporation with any unpaid Federal tax liability that has been assessed, for which all judicial and administrative remedies have been exhausted, or have lapsed, and that is not being paid in a timely manner pursuant to an agreement with the authority responsible for collecting the tax liability. (USDOT Order 4200.6 implementing appropriations act requirements)

b. Where the prospective lower tier participant is unable to certify to any of the statements in this certification, such prospective participant should attach an explanation to this proposal.

XI. CERTIFICATION REGARDING USE OF CONTRACT FUNDS FOR LOBBYING

This provision is applicable to all Federal-aid construction contracts and to all related subcontracts which exceed \$100,000. 49 CFR Part 20, App. A.

1. The prospective participant certifies, by signing and submitting this bid or proposal, to the best of his or her knowledge and belief, that:

a. No Federal appropriated funds have been paid or will be paid, by or on behalf of the undersigned, to any person for influencing or attempting to influence an officer or employee of any Federal agency, a Member of Congress, an officer or employee of Congress, or an employee of a Member of Congress in connection with the awarding of any Federal contract, the making of any Federal grant, the making of any Federal loan, the entering into of any cooperative agreement, and the extension, continuation, renewal, amendment, or modification of any Federal contract, grant, loan, or cooperative agreement.

b. If any funds other than Federal appropriated funds have been paid or will be paid to any person for influencing or attempting to influence an officer or employee of any Federal agency, a Member of Congress, an officer or employee of Congress, or an employee of a Member of Congress in connection with this Federal contract, grant, loan, or

cooperative agreement, the undersigned shall complete and submit Standard Form-LLL, "Disclosure Form to Report Lobbying," in accordance with its instructions.

2. This certification is a material representation of fact upon which reliance was placed when this transaction was made or entered into. Submission of this certification is a prerequisite for making or entering into this transaction imposed by 31 U.S.C. 1352. Any person who fails to file the required certification shall be subject to a civil penalty of not less than \$10,000 and not more than \$100,000 for each such failure.

3. The prospective participant also agrees by submitting its bid or proposal that the participant shall require that the language of this certification be included in all lower tier subcontracts, which exceed \$100,000 and that all such recipients shall certify and disclose accordingly.

XII. USE OF UNITED STATES-FLAG VESSELS:

This provision is applicable to all Federal-aid construction contracts, design-build contracts, subcontracts, lower-tier subcontracts, purchase orders, lease agreements, or any other covered transaction. 46 CFR Part 381.

This requirement applies to material or equipment that is acquired for a specific Federal-aid highway project. 46 CFR 381.7. It is not applicable to goods or materials that come into inventories independent of an FHWA funded-contract.

When oceanic shipments (or shipments across the Great Lakes) are necessary for materials or equipment acquired for a specific Federal-aid construction project, the bidder, proposer, contractor, subcontractor, or vendor agrees:

1. To utilize privately owned United States-flag commercial vessels to ship at least 50 percent of the gross tonnage (computed separately for dry bulk carriers, dry cargo liners, and tankers) involved, whenever shipping any equipment, material, or commodities pursuant to this contract, to the extent such vessels are available at fair and reasonable rates for United States-flag commercial vessels. 46 CFR 381.7.

2. To furnish within 20 days following the date of loading for shipments originating within the United States or within 30 working days following the date of loading for shipments originating outside the United States, a legible copy of a rated, 'on-board' commercial ocean bill-of-lading in English for each shipment of cargo described in paragraph (b)(1) of this section to both the Contracting Officer (through the prime contractor in the case of subcontractor bills-of-lading) and to the Office of Cargo and Commercial Sealift (MAR-620), Maritime Administration, Washington, DC 20590. (MARAD requires copies of the ocean carrier's (master) bills of lading, certified onboard, dated, with rates and charges. These bills of lading may contain business sensitive information and therefore may be submitted directly to MARAD by the Ocean Transportation Intermediary on behalf of the contractor). 46 CFR 381.7.

**ATTACHMENT A - EMPLOYMENT AND MATERIALS
PREFERENCE FOR APPALACHIAN DEVELOPMENT
HIGHWAY SYSTEM OR APPALACHIAN LOCAL ACCESS
ROAD CONTRACTS (23 CFR 633, Subpart B, Appendix B)**

This provision is applicable to all Federal-aid projects funded under the Appalachian Regional Development Act of 1965.

1. During the performance of this contract, the contractor undertaking to do work which is, or reasonably may be, done as on-site work, shall give preference to qualified persons who regularly reside in the labor area as designated by the DOL wherein the contract work is situated, or the subregion, or the Appalachian counties of the State wherein the contract work is situated, except:

a. To the extent that qualified persons regularly residing in the area are not available.

b. For the reasonable needs of the contractor to employ supervisory or specially experienced personnel necessary to assure an efficient execution of the contract work.

c. For the obligation of the contractor to offer employment to present or former employees as the result of a lawful collective bargaining contract, provided that the number of nonresident persons employed under this subparagraph (1c) shall not exceed 20 percent of the total number of employees employed by the contractor on the contract work, except as provided in subparagraph (4) below.

2. The contractor shall place a job order with the State Employment Service indicating (a) the classifications of the laborers, mechanics and other employees required to perform the contract work, (b) the number of employees required in each classification, (c) the date on which the participant estimates such employees will be required, and (d) any other pertinent information required by the State Employment Service to complete the job order form. The job order may be placed with the State Employment Service in writing or by telephone. If during the course of the contract work, the information submitted by the contractor in the original job order is substantially modified, the participant shall promptly notify the State Employment Service.

3. The contractor shall give full consideration to all qualified job applicants referred to him by the State Employment Service. The contractor is not required to grant employment to any job applicants who, in his opinion, are not qualified to perform the classification of work required.

4. If, within one week following the placing of a job order by the contractor with the State Employment Service, the State Employment Service is unable to refer any qualified job applicants to the contractor, or less than the number requested, the State Employment Service will forward a certificate to the contractor indicating the unavailability of applicants. Such certificate shall be made a part of the contractor's permanent project records. Upon receipt of this certificate, the contractor may employ persons who do not normally reside in the labor area to fill positions covered by the certificate, notwithstanding the provisions of subparagraph (1c) above.

5. The provisions of 23 CFR 633.207(e) allow the contracting agency to provide a contractual preference for the use of mineral resource materials native to the Appalachian region.

6. The contractor shall include the provisions of Sections 1 through 4 of this Attachment A in every subcontract for work which is, or reasonably may be, done as on-site work.

DOCUMENT 00811

SPECIAL PROVISIONS
MONTHLY PRICE ADJUSTMENT FOR HOT MIX ASPHALT (HMA) MIXTURES
Revised: 02/03/2023

This provision applies to all projects using greater than 100 tons of hot mix asphalt (HMA) mixtures containing liquid asphalt cement as stipulated in the Notice to Contractors section of the bid documents.

Price Adjustments will be based on the variance in price, for the liquid asphalt component only, between the Base Price and the Period Price. They shall not include transportation or other charges. Price Adjustments will occur on a monthly basis.

Base Price

The Base Price of liquid asphalt on a project as listed in the Notice to Contractors section of the bid documents is a fixed price determined by the Department at the time of the bid using the same method as the determination of the Period Price detailed below. The Base Price shall be used in all bids.

Period Price

The Period Price is the price of liquid asphalt for each monthly period as determined by the Department using the average selling price per standard ton of PG64-28 paving grade (primary binder classification) asphalt, FOB manufacturer's terminal, as listed under the "East Coast Market - New England, Boston, Massachusetts area" section of the Poten & Partners, Inc. "Asphalt Weekly Monitor". This average selling price is listed in the issue having a publication date of the second Friday of the month and will be posted as the Period Price for that month. The Department will post this Period Price on its website at <https://www.mass.gov/service-details/massdot-current-contract-price-adjustments> following its receipt of the relevant issue of the "Asphalt Weekly Monitor". Poten and Partners has granted the Department the right to publish this specific asphalt price information sourced from the Asphalt Weekly Monitor.

Price Adjustment Determination, Calculation and Payment

The Contract Price of the HMA mixture will be paid under the respective item in the Contract. Price Adjustments, as herein provided, either upwards or downwards, will be made after the work has been performed using the monthly period price for the month during which the work was performed.

Price Adjustments will be paid only if the variance from the Base Price is 5% or more for a monthly period. The complete adjustment will be paid in all cases with no deduction of the 5% from either upward or downward adjustments.

The Price Adjustment applies only to the actual virgin liquid asphalt content in the mixture placed on the job in accordance with the approved Job Mix Formula.

Price Adjustments will be separate payment items. The pay item numbers are 999.401 for a positive price adjustment (a payment) and 999.402 for a negative price adjustment (a deduction). Price Adjustments will be calculated using the following equation:

Price Adjustment = Tons of HMA Placed X Liquid Asphalt Content % X RAP Factor X (Period Price - Base Price)

No Price Adjustment will be allowed beyond the Completion Date of this Contract, unless there is a Department-approved extension of time.

***** END OF DOCUMENT *****

THIS PAGE INTENTIONALLY LEFT BLANK

DOCUMENT 00812

SPECIAL PROVISIONS
MONTHLY PRICE ADJUSTMENT FOR DIESEL FUEL AND GASOLINE –
ENGLISH UNITS
Revised: 02/01/2021

This monthly fuel price adjustment is inserted in this contract because the national and worldwide energy situation has made the future cost of fuel unpredictable. This adjustment will provide for either additional compensation to the Contractor or repayment to the Commonwealth, depending on an increase or decrease in the average price of diesel fuel or gasoline.

This adjustment will be based on fuel usage factors for various items of work developed by the Highway Research Board in Circular 158, dated July 1974. These factors will be multiplied by the quantities of work done in each item during each monthly period and further multiplied by the variance in price from the Base Price to the Period Price.

The Base Price of Diesel Fuel and Gasoline will be the price as indicated in the Department’s web site <https://www.mass.gov/service-details/massdot-current-contract-price-adjustments> for the month in which the contract was bid, which includes State Tax.

The Period Price will be the average of prices charged to the State, including State Tax for the bulk purchases made during each month.

This adjustment will be effected only if the variance from the Base Price is 5% or more for a monthly period. The complete adjustment will be paid in all cases with no deduction of the 5% from either upward or downward adjustments.

No adjustment will be paid for work done beyond the extended completion date of any contract.

Any adjustment (increase or decrease) to estimated quantities made to each item at the time of final payment will have the fuel price adjustment figured at the average period price for the entire term of the project for the difference of quantity.

The fuel price adjustment will apply only to the following items of work at the fuel factors shown:

ITEMS COVERED	FUEL FACTORS	
	Diesel	Gasoline
Excavation: and Borrow Work: Items 120, 120.1, 121, 123, 124, 125, 127, 129.3, 140, 140.1, 141, 142, 143, 144, 150, 150.1, 151 and 151.1 (Both Factors used)	0.29 Gallons / CY.	0.15 Gallons / CY
Surfacing Work: All Items containing Hot Mix Asphalt	2.90 Gallons / Ton	Does Not Apply

*** END OF DOCUMENT ***

THIS PAGE INTENTIONALLY LEFT BLANK

DOCUMENT 00813

SPECIAL PROVISIONS

PRICE ADJUSTMENTS FOR STRUCTURAL STEEL AND REINFORCING STEEL

December 12, 2024

This special provision applies to all projects containing the use of structural steel and/or reinforcing steel as specified elsewhere in the Contract work. It applies to all structural steel and all reinforcing steel, as defined below, on the project. Compliance with this provision is mandatory, i.e., there are no “opt-in” or “opt-out” clauses. Price adjustments will be handled as described below and shall only apply to unfabricated reinforcing steel bars and unfabricated structural steel material, consisting of rolled shapes, plate steel, sheet piling, pipe piles, steel castings and steel forgings.

Price adjustments will be variances between Base Prices and Period Prices. Base Prices and Period Prices are defined below.

Price adjustments will only be made if the variances between Base Prices and Period Prices are 5% or more. A variance can result in the Period Price being either higher or lower than the Base Price. Once the 5% threshold has been achieved, the adjustment will apply to the full variance between the Base Price and the Period Price.

Price adjustments will be calculated by multiplying the number of pounds of unfabricated structural steel material or unfabricated reinforcing steel bars on a project by the index factor calculated as shown below under Example of a Period Price Calculation.

Price adjustments will not include guardrail panels or the costs of shop drawing preparation, handling, fabrication, coatings, transportation, storage, installation, profit, overhead, fuel costs, fuel surcharges, or other such charges not related to the cost of the unfabricated structural steel and unfabricated reinforcing steel.

The weight of steel subject to a price adjustment shall not exceed the final shipping weight of the fabricated part by more than 10%.

Base Prices and Period Prices are defined as follows:

Base Prices of unfabricated structural steel and unfabricated reinforcing steel on a project are fixed prices determined by the Department and found in the table below. While it is the intention of the Department to make this table comprehensive, some of a project’s unfabricated structural steel and/or unfabricated reinforcing steel may be inadvertently omitted. Should this occur, the Contractor shall bring the omission to the Department’s attention so that a contract alteration may be processed that adds the missing steel to the table and its price adjustments to the Contract.

The Base Price Date is the month and year of the most recent finalized period price index at the time that MassDOT opened bids for the project. The Base Price Index for this contract is the Steel PPI listed in the Notice to Contractors.

Period Prices of unfabricated structural steel and unfabricated reinforcing steel on a project are variable prices that have been calculated using the Period Price Date and an index of steel prices to adjust the Base Price.

The Period Price Date is the date the steel was delivered to the fabricator as evidenced by an official bill of lading submitted to the Department containing a description of the shipped materials, weights of the shipped materials and the date of shipment. This date is used to select the Period Price Index.

The index used for the calculation of Period Prices is the U.S. Department of Labor Bureau of Labor Statistics Producer Price Index (PPI) Series ID WPU101702 (Not Seasonally Adjusted, Group: Metals and Metal Products, Item: Semi-finished Steel Mill Products.) As this index is subject to revision for a period of up to four (4) months after its original publication, no price adjustments will be made until the index for the period is finalized, i.e., the index is no longer suffixed with a “(P)”.

Period Prices are determined as follows:

Period Price = Base Price X Index Factor

Index Factor = Period Price Index / Base Price Index

Example of a Period Price Calculation:

Calculate the Period Price for December 2009 using a Base Price from March 2009 of \$0.82/Pound for 1,000 Pounds of ASTM A709 (AASHTO M270) Grade A36 Structural Steel Plate.

The Period Price Date is December 2009. From the PPI website*, the Period Price Index = 218.0.

The Base Price Date is March 2009. From the PPI website*, the Base Price Index = 229.4.

Index Factor = Period Price Index / Base Price Index = 218.0 / 229.4 = 0.950

Period Price = Base Price X Index Factor = \$0.82/Pound X 0.950 = \$0.78/Pound

Since \$0.82 - \$0.78 = \$0.04 is less than 5% of \$0.82, no price adjustment is required.

If the \$0.04 difference shown above was greater than 5% of the Base Price, then the price adjustment would be 1,000 Pounds X \$0.04/Pound = \$40.00. Since the Period Price of \$0.78/Pound is less than the Base Price of \$0.82/Pound, indicating a drop in the price of steel between the bid and the delivery of material, a credit of \$40.00 would be owed to MassDOT. When the Period Price is higher than the Base Price, the price adjustment is owed to the Contractor.

* To access the PPI website and obtain a Base Price Index or a Period Price Index, go to

<http://data.bls.gov/cgi-bin/srgate>

End of example.

The Contractor will be paid for unfabricated structural steel and unfabricated reinforcing steel under the respective contract pay items for all components constructed of either structural steel or reinforced Portland cement concrete under their respective Contract Pay Items.

Price adjustments, as herein provided for, will be paid separately as follows:

Structural Steel

Pay Item Number 999.449 for positive (+) pay adjustments (payments to the Contractor)

Pay Item Number 999.457 for negative (-) pay adjustments (credits to MassDOT Highway Division)

Reinforcing Steel

Pay Item Number 999.466 for positive (+) pay adjustments (payments to the Contractor)

Pay Item Number 999.467 for negative (-) pay adjustments (credits to MassDOT Highway Division)

No price adjustment will be made for price changes after the Contract Completion Date, unless the MassDOT Highway Division has approved an extension of Contract Time for the Contract.

TABLE

Steel Type	Price per Pound	
1	ASTM A615/A615M Grade 60 (AASHTO M31 Grade 60 or 420) Reinforcing Steel	\$0.58
2	ASTM A27 (AASHTO M103) Steel Castings, H-Pile Points & Pipe Pile Shoes (See Note below.)	\$0.81
3	ASTM A668 / A668M (AASHTO M102) Steel Forgings	\$0.81
4	ASTM A108 (AASHTO M169) Steel Forgings for Shear Studs	\$0.84
5	ASTM A709/A709M Grade 36 / AASHTO M270M/M270 Grade 36 or 250 Structural Steel Plate	\$0.89
6	ASTM A709/A709M Grade 36 / AASHTO M270M/M270 Grade 36 or 250 Structural Steel Shapes	\$0.83
7	ASTM A709/A709M Grade 50 / AASHTO M270M/M270 Grade 50 or 345 Structural Steel Plate	\$0.89
8	ASTM A709/A709M Grade 50 / AASHTO M270M/M270 Grade 50 or 345 Structural Steel Shapes	\$0.83
9	ASTM A709/A709M Grade 50WT / AASHTO M270M/M270 Grade 50WT or 345WT Structural Steel Plate	\$0.92
10	ASTM A709/A709M Grade 50WT / AASHTO M270M/M270 Grade 50WT or 345WT Structural Steel Shapes	\$0.84
11	ASTM A709/A709M Grade 50W / AASHTO M270M/M270 Grade 50W 345W Structural Steel Plate	\$0.92
12	ASTM A709/A709M Grade 50W / AASHTO M270M/M270 Grade 50W or 345W Structural Steel Shapes	\$0.84
13	ASTM A709/A709M Grade HPS 50W / AASHTO M270M/M270 Grade HPS 50W or 345W Structural Steel Plate	\$0.96
14	ASTM A709/A709M Grade HPS 70W / AASHTO M270M/M270 Grade HPS 70W or 485W Structural Steel Plate	\$1.03
15	ASTM A514/A514M-05 Grade HPS 100W / AASHTO M270M/M270 Grade HPS 100W or 690W Structural Steel Plate	\$1.58
16	ASTM A992/A992M Grade 50S / AASHTO M270M/M270 Grade 50S or 345S Structural Steel Plate	\$0.92
17	ASTM A992/A992M Grade 50S / AASHTO M270M/M270 Grade 50S or 345S Structural Steel Shapes	\$0.84
18	ASTM A276 Type 316 Stainless Steel	\$4.71
19	ASTM A240 Type 316 Stainless Steel	\$4.71
20	ASTM A148 Grade 80/50 Steel Castings (See Note below.)	\$1.62
21	ASTM A53 Grade B Structural Steel Pipe	\$1.03
22	ASTM A500 Grades A, B, 36 & 50 Structural Steel Pipe	\$1.03
23	ASTM A252, Grades 240 (36 KSI) & 414 (60 KSI) Pipe Pile	\$0.82
24	ASTM 252, Grade 2 Permanent Steel Casing	\$0.82
25	ASTM A36 (AASHTO M183) for H-piles, steel supports and sign supports	\$0.87
26	ASTM A328 / A328M, Grade 50 (AASHTO M202) Steel Sheetpiling	\$1.55
27	ASTM A572 / A572M, Grade 50 Sheetpiling	\$1.55
28	ASTM A36/36M, Grade 50	\$0.89
29	ASTM A570, Grade 50	\$0.87
30	ASTM A572 (AASHTO M223), Grade 50 H-Piles	\$0.89
31	ASTM A1085 Grade A (50 KSI) Steel Hollow Structural Sections (HSS), heat-treated per ASTM A1085 Supplement S1	\$1.03
32	AREA 140 LB Rail and Track Accessories	\$0.53

NOTE: Steel Castings are generally used only on moveable bridges. Cast iron frames, grates and pipe are not "steel" castings and will not be considered for price adjustments.

END OF DOCUMENT

THIS PAGE IS INTENTIONALLY LEFT BLANK

DOCUMENT 00814

SPECIAL PROVISIONS
PRICE ADJUSTMENT FOR PORTLAND CEMENT CONCRETE MIXES

January 12, 2009

This provision applies to all projects using greater than 100 Cubic Yards (76 Cubic Meters) of Portland cement concrete containing Portland cement as stipulated in the Notice to Contractors section of the Bid Documents. This Price Adjustment will occur on a monthly basis.

The Price Adjustment will be based on the variance in price for the Portland cement component only from the Base Price to the Period Price. It shall not include transportation or other charges.

The Base Price of Portland cement on a project is a fixed price determined at the time of bid by the Department by using the same method as for the determination of the Period Price (see below) and found in the Notice to Contractors.

The Period Price of Portland cement will be determined by using the latest published price, in dollars per ton (U.S.), for Portland cement (Type I) quoted for Boston, U.S.A. in the **Construction Economics** section of *ENR Engineering News-Record* magazine or at the ENR website <http://www.enr.com> under **Construction Economics**. The Period Price will be posted on the MassDOT website the Wednesday immediately following the publishing of the monthly price in ENR, which is normally the first week of the month.

The Contract Price of the Portland cement concrete mix will be paid under the respective item in the Contract. The price adjustment, as herein provided, upwards or downwards, will be made after the work has been performed, using the monthly period price for the month during which the work was performed.

The price adjustment applies only to the actual Portland cement content in the mix placed on the job in accordance with the Standard Specifications for Highways and Bridges, Division III, Section M4.02.01. No adjustments will be made for any cement replacement materials such as fly ash or ground granulated blast furnace slag.

The Price Adjustment will be a separate payment item. It will be determined by multiplying the number of cubic yards of Portland cement concrete placed during each monthly period times the Portland cement content percentage times the variance in price between the Base Price and Period Price of Portland cement.

This Price Adjustment will be paid only if the variance from the Base Price is 5% or more for a monthly period. The complete adjustment will be paid in all cases with no deduction of the 5% from either upward or downward adjustments.

No Price Adjustment will be allowed beyond the Completion Date of this Contract, unless there is a Department-approved extension of time.

*** END OF DOCUMENT ***

THIS PAGE INTENTIONALLY LEFT BLANK

DOCUMENT 00820

**THE COMMONWEALTH OF MASSACHUSETTS
SUPPLEMENTAL EQUAL EMPLOYMENT OPPORTUNITY,
NON-DISCRIMINATION AND AFFIRMATIVE ACTION PROGRAM**

I. Definitions

For purposes of this contract,

"Minority" means a person who meets one or more of the following definitions:

- (a) American Indian or Native American means: all persons having origins in any of the original peoples of North America and who are recognized as an Indian by a tribe or tribal organization.
- (b) Asian means: All persons having origins in any of the original peoples of the Far East, Southeast Asia, the Indian sub-continent, or the Pacific Islands, including, but Not limited to China, Japan, Korea, Samoa, India, and the Philippine Islands.
- (c) Black means: All persons having origins in any of the Black racial groups of Africa, including, but not limited to, African-Americans, and all persons having origins in any of the original peoples of the Cape Verdean Islands.
- (d) Eskimo or Aleut means: All persons having origins in any of the peoples of Northern Canada, Greenland, Alaska, and Eastern Siberia.
- (e) Hispanic means: All persons having their origins in any of the Spanish-speaking peoples of Mexico, Puerto Rico, Cuba, Central or South America, or the Caribbean Islands.

"State construction contract" means a contract for the construction, reconstruction, installation, demolition, maintenance or repair of a building or capital facility, or a contract for the construction, reconstruction, alteration, remodeling or repair of a public work undertaken by a department, agency, board, or commission of the commonwealth.

"State assisted construction contract" means a contract for the construction, reconstruction, installation, demolition, maintenance or repair of a building or capital facility undertaken by a political subdivision of the commonwealth, or two or more political subdivisions thereof, an authority, or other instrumentality and whose costs of the contract are paid for, reimbursed, grant funded, or otherwise supported, in whole or in part, by the commonwealth.

II. Equal Opportunity, Non-Discrimination and Affirmative Action

During the performance of this Contract, the Contractor and all subcontractors (hereinafter collectively referred to as "the Contractor") for a state construction contract or a state assisted construction contract, for him/herself, his/her assignees and successors in interest, agree to comply with all applicable equal employment opportunity, non-discrimination and affirmative action requirements, including but not limited to the following:

In connection with the performance of work under this contract, the Contractor shall not discriminate against any employee or applicant for employment because of race, color, religious creed, national origin, sex, sexual orientation, genetic information, military service, age, ancestry or disability, shall not discriminate in the selection or retention of subcontractors, and shall not discriminate in the procurement of materials and rentals of equipment.

The aforesaid provision shall include, but not be limited to, the following: employment upgrading, demotion, or transfer; recruitment advertising, layoff or termination; rates of pay or other forms of compensation; conditions or privileges of employment; and selection for apprenticeship or on-the-job training opportunity. The Contractor shall comply with the provisions of chapter 151B of the Massachusetts General Laws, as amended, and all other applicable anti-discrimination and equal opportunity laws, all of which are herein incorporated by reference and made a part of this Contract.

The Contractor shall post hereafter in conspicuous places, available for employees and applicants for employment, notices to be provided by the Massachusetts Commission Against Discrimination setting forth the provisions of the Fair Employment Practices Law of the Commonwealth (Massachusetts General Laws Chapter 151 B).

In connection with the performance of work under this contract, the Contractor shall undertake, in good faith, affirmative action measures to eliminate any discriminatory barriers in the terms and conditions of employment on the grounds of race, color, religious creed, national origin, sex, sexual orientation, genetic information, military service, age, ancestry or disability. Such affirmative action measures shall entail positive and aggressive measures to ensure nondiscrimination and to promote equal opportunity in the areas of hiring, upgrading, demotion or transfer, recruitment, layoff or termination, rate of compensation, apprenticeship and on-the-job training programs. A list of positive and aggressive measures shall include, but not be limited to, advertising employment opportunities in minority and other community news media; notifying minority, women and other community-based organizations of employment opportunities; validating all job specifications, selection requirements, and tests; maintaining a file of names and addresses of each worker referred to the Contractor and what action was taken concerning such worker; and notifying the administering agency in writing when a union with whom the Contractor has a collective bargaining agreement has failed to refer a minority or woman worker. These and other affirmative action measures shall include all actions required to guarantee equal employment opportunity for all persons, regardless of race, color, religious creed, national origin, sex, sexual orientation, genetic information, military service, age, ancestry or disability. One purpose of this provision is to ensure to the fullest extent possible an adequate supply of skilled tradesmen for this and future Commonwealth public construction projects.

III. Minority and Women Workforce Participation

Pursuant to his/her obligations under the preceding section, the Contractor shall strive to achieve on this project the labor participation goals contained herein. Said participation goals shall apply in each job category on this project including but not limited to bricklayers, carpenters, cement masons, electricians, ironworkers, operating engineers and those classes of work enumerated in Section 44F of Chapter 149 of the Massachusetts General Laws. The participation goals for this project shall be 15.3% for minorities and 6.9% for women. The participation goals, as set forth herein, shall not be construed as quotas or set-asides; rather, such participation goals will be used to measure the progress of the Commonwealth's equal opportunity, non-discrimination and affirmative action program. Additionally, the participation goals contained herein should not be seen or treated as a floor or as a ceiling for the employment of particular individuals or group of individuals.

IV. Liaison Committee

At the discretion of the agency that administers the contract for the construction project there may be established for the life of the contract a body to be known as the Liaison Committee. The Liaison Committee shall be composed of one representative each from the agency or agencies administering the contract for the construction project, hereinafter called the administering agency, a representative from the Office of Affirmative action, and such other representatives as may be designated by the administering agency. The Contractor (or his/her agent, if any, designated by him/her as the on-site equal employment opportunity officer) shall recognize the Liaison Committee as an affirmative action body, and shall establish a continuing working relationship with the Liaison Committee, consulting with the Liaison Committee on all matters related to minority recruitment, referral, employment and training.

V. Reports and Records

The Contractor shall prepare projected workforce tables on a quarterly basis when required by the administering agency. These shall be broken down into projections, by week, of workers required in each trade. Copies shall be furnished one week in advance of the commencement of the period covered, and also, when updated, to the administering agency and the Liaison Committee when required.

The Contractor shall prepare weekly reports in a form approved by the administering agency, unless information required is required to be reported electronically by the administering agency, the number of hours worked in each trade by each employee, identified as woman, minority, or non-minority. Copies of these shall be provided at the end of each such week to the administering agency and the Liaison Committee.

Records of employment referral orders, prepared by the Contractor, shall be made available to the administering agency on request.

The Contractor will provide all information and reports required by the administering agency on instructions issued by the administering agency and will permit access to its facilities and any books, records, accounts and other sources of information which may be determined by the administering agency to effect the employment of personnel. This provision shall apply only to information pertinent to the Commonwealth's supplementary non-discrimination, equal opportunity and access and opportunity contract requirements. Where information required is in the exclusive possession of another who fails or refuses to furnish this information, the Contractor shall so certify to the administering agency and shall set forth what efforts he has made to obtain the information.

VI. Access to Work Site

A designee of the administering agency and a designee of the Liaison Committee shall each have a right to access the work site.

VII. Solicitations for Subcontracts, and for the Procurement of Materials and Equipment

In all solicitations either by competitive bidding or negotiation made by the Contractor either for work to be performed under a subcontract or for the procurement of materials or equipment, each potential subcontractor or supplier shall be notified in writing by the Contractor of the Contractor's obligations under this contract relative to non-discrimination and equal opportunity.

VIII. Sanctions

Whenever the administering agency believes the General or Prime Contractor or any subcontractor may not be operating in compliance with the provisions of the Fair Employment Practices Law of the Commonwealth (Massachusetts General Laws Chapter 151B), the administering agency may refer the matter to the Massachusetts Commission Against Discrimination ("Commission") for investigation.

Following the referral of a matter by the administering agency to the Massachusetts Commission Against Discrimination, and while the matter is pending before the MCAD, the administering agency may withhold payments from contractors and subcontractors when it has documentation that the contractor or subcontractor has violated the Fair Employment Practices Law with respect to its activities on the Project, or if the administering agency determines that the contractor has materially failed to comply with its obligations and the requirements of this Section. The amount withheld shall not exceed a withhold of payment to the General or Prime Contractor of 1/100 or 1% of the contract award price or \$5,000, whichever sum is greater, or, if a subcontractor is in non-compliance, a withhold by the administering agency from the General Contractor, to be assessed by the General Contractor as a charge against the subcontractor, of 1/100 or 1% of the subcontractor price, or \$1,000 whichever sum is greater, for each violation of the applicable law or contract requirements. The total withheld from anyone General or Prime Contractor or subcontractor on a Project shall not exceed \$20,000 overall. No withhold of payments or investigation by the Commission or its agent shall be initiated without the administering agency providing prior notice to the Contractor.

If, after investigation, the Massachusetts Commission Against Discrimination finds that a General or Prime Contractor or subcontractor, in commission of a state construction contract or state-assisted construction contract, violated the provisions of the Fair Employment Practices Law, the administering agency may convert the amount withheld as set forth above into a permanent sanction, as a permanent deduct from payments to the General or Prime Contractor or subcontractor, which sanction will be in addition to any such sanctions, fines or penalties imposed by the Massachusetts Commission Against Discrimination.

No sanction enumerated under this Section shall be imposed by the administering agency except after notice to the General or Prime Contractor or subcontractor and an adjudicatory proceeding, as that term is used, under Massachusetts General Laws Chapter 30A, has been conducted.

IX. Severability

The provisions of this section are severable, and if any of these provisions shall be held unconstitutional by any court of competent jurisdiction, the decision of such court shall not affect or impair any of the remaining provisions.

X. Contractor's Certification

After award and prior to the execution of any contract for a state construction contract or a state assisted construction contract, the Prime or General Contractor shall certify that it will comply with all provisions of this Document 00820 Supplemental Equal Employment Opportunity, Non-Discrimination and Affirmative Action Program, by executing Document 00859 Contractor/Subcontractor Certification Form.

XI. Subcontractor Requirements

Prior to the award of any subcontract for a state construction contract or a state assisted construction contract, the Prime or General Contractor shall provide all prospective subcontractors with a complete copy of this Document 00820 entitled "Supplemental Equal Employment Opportunity, Non-Discrimination and Affirmative Action Program" and will incorporate the provisions of this Document 00820 into any and all contracts or work orders for all subcontractors providing work on the Project. In order to ensure that the said subcontractor's certification becomes a part of all subcontracts under the prime contract, the Prime or General Contractor shall certify in writing to the administering agency that it has complied with the requirements as set forth in the preceding paragraph by executing Document 00859 Contractor/Subcontractor Certification Form.

Rev'd 03/07/14

*** END OF DOCUMENT ***

THIS PAGE INTENTIONALLY LEFT BLANK

DOCUMENT 00821

ELECTRONIC REPORTING REQUIREMENTS
CIVIL RIGHTS PROGRAMS AND CERTIFIED PAYROLL

Implemented on March 2, 2009

Revised June 04, 2019

The Massachusetts Department Of Transportation (MassDOT) has replaced the CHAMP reporting system with Equitable Business Opportunity Solution (EBO), a new web-based civil rights reporting software system. This system is capable of handling both civil rights reporting requirements and certified payrolls. The program's functions include the administration of Equal Employment Opportunity (EEO) requirements, On-The-Job Training requirements (OJT), Disadvantage Business Enterprise (DBE) and/or Minority / Women's Business Enterprise (M/WBE) subcontracting requirements, and the electronic collection of certified payrolls associated with MassDOT projects. In addition, this system is used to generate various data required as part of the American Recovery and Reinvestment Act (ARRA). Contractors are responsible for all coordination with all sub-contractors to ensure timely and accurate electronic submission of all required data.

Contractor and Sub-Contractor EBO User Certification

All contractors and sub-contractors must use the EBO software system. The software vendor, Internet Government Solutions (IGS), has developed an online EBO Training Module that is available to contractors and sub-contractors. This module is a self-tutorial which allows all users in the company to access the training, complete the tutorial, and become certified as EBO users for a one time fee of \$75.00. This is the only cost to contractors and sub-contractors associated with the EBO software system. The online EBO Training Module can be accessed at www.ebotraining.com. Click the "Register My Company" button on the login page to begin your training registration. Questions regarding EBO online training should be directed to Gerry Anguilano, IGS at (440) 238-1684.

MassDOT will track contractors and sub-contractors who have successfully completed the on-line training module. All persons performing civil rights program and/or certified payroll functions should be EBO certified.

Vetting of Firms and Designated Firm Individuals

Contractors must authorize a Primary Log-In ID Holder who has completed EBO on-line training to have access to the EBO system by completing and submitting the "Request For EBO System Log-In/Password Form" located on the MassDOT website at: <https://www.mass.gov/how-to/how-to-get-an-ebo-login>. Contractors must also agree to comply with the EBO system user agreement located on the MassDOT website.

All subcontracts entered into on a project must include language that identifies the submission and training requirements that the sub-contractor must perform. Sub-contractors will be approved by the respective District Office of MassDOT through the existing approval process. When new sub-contractors, who have not previously worked for MassDOT, are initially selected by a general contractor, the new sub-contractor must be approved by the District before taking the EBO on-line training module.

Interim Reporting Requirements

Until MassDOT is satisfied that the EBO system is fully operational and functioning as designed, contractors and sub-contractors will be required to submit certified payrolls manually. There will be a transition period where dual reporting, through manual and electronic submission, will be required. MassDOT, however, will notify contractors and sub-contractors when they may cease manual submission of certified payrolls.

*** END OF DOCUMENT ***

THIS PAGE INTENTIONALLY LEFT BLANK

DOCUMENT 00859

CONTRACTOR/SUBCONTRACTOR CERTIFICATION FORM ‡

The contractor shall submit this completed document 00859 to MassDOT for each subcontract.

_____ (Contractor) Date: _____

_____ (Subcontractor) District Approved Subcontractor

Contract No: 129070 Project No. 612097 Federal Aid No.: NHP(IM)/HIP(BR)-0912(310)X

Location: WEST SPRINGFIELD - CHICOPEE

Project Description: Pavement and Bridge Preservation on I-91

PART 1 CONTRACTOR CERTIFICATION: I hereby certify, as an authorized official of this company, that to the best of my knowledge, information and belief, the company is in compliance with all applicable federal and state laws, rules, and regulations governing fair labor and employment practices, that the company will not discriminate in their employment practices, that the company will make good faith efforts to comply with the minority employee and women employee workforce participation ratio goals and specific affirmative action steps contained in Contract Document 00820 The Commonwealth of Massachusetts Supplemental Equal Employment Opportunity, Non-Discrimination and Affirmative Action Program, and that the company will comply with the special provisions and documentation indicated below (as checked).

I further hereby certify, as an authorized official of this company, that the special provisions and documentation indicated below (as checked) have been or are included in, and made part of, the Subcontractor Agreement entered into with the firm named above.

This is not a Federally-aided construction project

Document #

- 00718 –Participation By Minority Or Women's Business Enterprises and SDVOBE†
- 00761 –Certification Regarding Debarment, Suspension, Ineligibility, and Voluntary Exclusion
- 00820 – MA Supplemental Equal Employment Opportunity, Non-Discrimination, and Affirmative Action Program
- 00821 – Electronic Reporting Requirements, Civil Rights Programs, and Certified Payroll
- 00859 – Contractor/Subcontractor Certification Form (this document)
- 00860 – MA Employment Laws
- 00861 – Applicable State Wage Rates in the Contract Proposal**
- B00842 – MA Schedule of Participation By Minority or Women Business Enterprises (M/WBEs)†
- B00843 – MA Letter of Intent – M/WBEs†
 - ** Does not apply to Material Suppliers, unless performing work on-site
 - † Applies only if Subcontractor is a M/WBE; only include these forms for the particular M/WBE Entity
- B00844 - Schedule of Participation By SDVOBE
- B00845 - Letter of Intent – SDVOBE
- B00846 – M/WBE or SDVOBE Joint Check Arrangement Approval Form
- B00847 – Joint Venture Affidavit

This is a Federally-aided construction project (Federal Aid Number is present)

Document #

- 00719 – Special Provisions for Participation by Disadvantaged Business Enterprises†
- 00760 - Form FHWA 1273 - Required Contract Provisions for Federal-Aid Construction Contracts
- 00820 – MA Supplemental Equal Employment Opportunity, Non-Discrimination and Affirmative Action Program
- 00821 – Electronic Reporting Requirements, Civil Rights Programs and Certified Payroll
- 00859 – Contractor/Subcontractor Certification Form (this document)
- 00860 – MA Employment Laws
- 00870 – Standard Federal Equal Employment Opportunity Construction Contract Specifications Executive Order 11246, (41 CFR Parts 60-4.2 and 60-4.3 (Solicitations and Equal Opportunity Clauses)*
- 00875 – Federal Trainee Special Provisions



- B00853 – Schedule of Participation by Disadvantaged Business Enterprise†
- B00854 – Letter of Intent – DBEs†
- B00855 – DBE Joint Check Arrangement Approval Form
- B00856 – Joint Venture Affidavit
- 00861/00880 - Applicable state and federal wage rates from Contract Proposal**

*Applicable only to Contracts or Subcontracts in excess of \$10,000

**Does not apply to Material Suppliers, unless performing work on-site

† Applies only if Subcontractor is a DBE; only include these forms for the particular DBE Entity

Signed this _____ Day of _____, 20____ Under The Pains And Penalties Of Perjury.

(Print Name and Title)

(Authorized Signature)

PART 2

PART 2. SUBCONTRACTOR CERTIFICATION: I hereby certify, as an authorized official of this company, that the required documents in Part 1 above were physically incorporated in our Agreement/Subcontract with the Contractor and give assurance that this company will fully comply or make every good faith effort to comply with the same. I further certify that:

1. This company recognizes that if this is a Federal-Aid Project, then this Contract is covered by the equal employment opportunity laws administered and enforced by the United States Department of Labor (“USDOL”), Office of Federal Contract Compliance Programs (“OFCCP”). By signing below, we acknowledge that this company has certain reporting obligations to the OFCCP, as specified by 41 CFR Part 60-4.2.
2. This company further acknowledges that any contractor with fifty (50) or more employees on a Federal-aid Contract with a value of fifty-thousand (\$50,000) dollars or more must annually file an EEO-1 Report (SF 100) to the EEOC, Joint Reporting Committee, on or before September 30th, each year, as specified by 41 CFR Part 60-1.7a.
3. For more information regarding the federal reporting requirements, please contact the USDOL, OFCCP Regional Office, at 1-646-264-3170 or EEO-1, Joint Reporting Committee at 1-866-286-6440. You may also find guidance at: <http://www.dol.gov/ofccp/TAGuides/consttag.pdf> or <http://www.wdol.gov/dba.aspx#0>.
4. This company has, has not, participated in a previous contract or subcontract subject to the Equal Opportunity clauses set forth in 41 CFR Part 60-4 and Executive Order 11246, and where required, has filed with the Joint Reporting Committee, the Director of the Office of Federal Contract Compliance Programs or the EEO Commission all reports due under the applicable filing requirements.
5. This company is in full compliance with applicable Federal and Commonwealth of Massachusetts laws, rules, and regulations and is not currently debarred or disqualified from bidding on or participating in construction contracts in any jurisdiction of the United States. See : <https://www.mass.gov/service-details/contractors-and-vendors-suspended-or-debarred-by-massdot>
6. This company is properly registered and in good standing with the Office of the Secretary of the Commonwealth.

Signed this _____ Day of _____, 20____, Under The Pains And Penalties Of Perjury.

Firm: _____

Address: _____

(Print Name and Title)

Telephone Number: _____

Federal I.D. Number: _____

(Authorized Signature)

Estimated Start Date: _____

Estimated Completion Date: _____

Estimated Dollar Amount: _____

(Date)

DOCUMENT 00860

COMMONWEALTH OF MASSACHUSETTS PUBLIC EMPLOYMENT LAWS

Revised February 20, 2019

The Contractor's attention is directed to Massachusetts General Laws, Chapter 149, Sections 26 through 27H, and 150A. This contract is considered to fall within the ambit of that law, which provides that in general, the Prevailing Rate or Total Rate must be paid to employees working on projects funded by the Commonwealth of Massachusetts or any political subdivision including Massachusetts Department of Transportation (MassDOT).

A Federal Aid project is also subject to the Federal Minimum Wage Rate law for construction. When comparing a state minimum wage rate, monitored by the Massachusetts Attorney General, versus federal minimum wage rate, monitored by the U.S. Department of Labor Wage and Hour Division, for a particular job classification the higher wage is at all times to be paid to the affected employee.

Every contractor or subcontractor engaged in this contract to which sections twenty-seven and twenty-seven A apply will keep a true and accurate record of all mechanics and apprentices, teamsters, chauffeurs and laborers employed thereon, showing the name, address and occupational classification of each such employee on this contract, and the hours worked by, and the wages paid to, each such employee, and shall furnish to the MassDOT's Resident Engineer, on a weekly basis, a copy of said record, in a form approved by MassDOT and in accordance with M.G.L. c. 149, § 27B, signed by the employer or his/her authorized agent under the penalties of perjury.

Each such contractor or subcontractor shall preserve its payroll records for a period of three years from the date of completion of the contract.

The Prevailing Wage Rate generally includes the following:

Minimum Hourly Wage + Employer Contributions to Benefit Plans = Prevailing Wage Rate or Total Rate

Any employer who does not make contributions to Benefit Plans must pay the total Prevailing Wage Rate directly to the employee.

Any deduction from the Prevailing Wage Rate or Total Rate for contributions to benefit plans can only be for a Health & Welfare, Pension, or Supplementary Unemployment plan meeting the requirements of the Employee Retirement Income Security Act (ERISA) of 1974. The maximum allowable deduction for these benefits from the prevailing wage rate cannot be greater than the amount allowed by Executive Office of Labor (EOL) for the specified benefits. Any additional expense of providing benefits to the employees is to be borne by the employer and cannot be deducted from the Minimum Hourly Wage. If the employer's benefit expense is less than that so provided by EOL the difference will be paid directly to the employee. The rate established must be paid to all employees who perform work on the project.

When an employer makes deductions from the Minimum Hourly Wage for an employee's contribution to social security, state taxes, federal taxes, and/or other contribution programs, allowed by law, the employer shall furnish each employee a suitable pay slip, check stub or envelope notifying the employee of the amount of the deductions.

No contractor or subcontractor contracting for any part of the contract week shall require or permit any laborer or mechanic to be employed on such work in excess of forty hours in any workweek unless such laborer or mechanic receives compensation at a rate not less than one and one-half times his basic rate of pay for all hours worked in excess of forty hours in such workweek, whichever is the greater number of overtime hours.

Apprentice Rates are permitted only when there is an Apprentice Agreement registered with the Massachusetts Division of Apprentice Training in accordance with M.G.L. c. 23, § 11E-11L.

The Prevailing Wage Rates issued for each project shall be the rates paid for the entire project. The Prevailing Wage Rates must be posted on the job site at all times and be visible from a public way.

In addition, each such contractor and subcontractor shall furnish to the MassDOT's Resident Engineer, within fifteen days after completion of its portion of the work, a statement, executed by the contractor or subcontractor or by any authorized officer or employee of the contractor or subcontractor who supervises the payment of wages, in the following form:

STATEMENT OF COMPLIANCE

Date: _____

I, _____ do hereby state:
(Name of signatory party) (Title)

That I pay or supervise the payment of the persons employed by:

(Contractor or Subcontractor)

on the _____
(MassDOT Project Location and Contract Number)

and that all mechanics and apprentices, teamsters, chauffeurs and laborers employed on said project have been paid in accordance with wages determined under the provisions of sections twenty-six and twenty-seven of chapter one hundred and forty-nine of the General Laws.

Signature _____

Title _____

The above-mentioned copies of payroll records and statements of compliance shall be available for inspection by any interested party filing a written request to the MassDOT's Resident Engineer for such inspection and copying.

Massachusetts General Laws c. 149, §27, requires annual updates to prevailing wage schedules for all public construction contracts lasting longer than one year. MassDOT will request the required updates and furnish them to the Contractor. The Contractor is required to pay no less than the wage rates indicated on the annual updated wage schedules.

MassDOT will request the updates no later that two week before the anniversary of the Notice to Proceed date of the contract to allow for adequate processing by the Department of Labor Standards (DLS). The effective date for the new rates will be the anniversary date of the contract (i.e. the notice to proceed date), regardless of the date of issuance on the schedule from DLS.

All bidders are cautioned that the aforementioned laws require that employers pay to covered employees no less than the applicable minimum wages. In addition, the same laws require that the applicable prevailing wages become incorporated as part of this contract. The prevailing minimum wage law establishes serious civil and criminal penalties for violations, including imprisonment and exclusion from future public contracts. Bidders are cautioned to carefully read the relevant sections of the Massachusetts General Laws.

*** END OF DOCUMENT ***

DOCUMENT 00861

STATE PREVAILING WAGE RATES

THIS PAGE INTENTIONALLY LEFT BLANK



MAURA HEALEY
Governor

KIM DRISCOLL
Lt. Governor

THE COMMONWEALTH OF MASSACHUSETTS
EXECUTIVE OFFICE OF LABOR AND WORKFORCE DEVELOPMENT
DEPARTMENT OF LABOR STANDARDS

Prevailing Wage Rates

As determined by the Director under the provisions of the
Massachusetts General Laws, Chapter 149, Sections 26 to 27H

LAUREN JONES
Secretary

MICHAEL FLANAGAN
Director

Awarding Authority: MassDOT Highway
Contract Number: 129070 **City/Town:** WEST SPRINGFIELD
Description of Work: WEST SPRINGFIELD - CHICOPEE - Federal Aid Project No. NHP(IM)/HIP(BR)-0912(310)X Pavement and Bridge Preservation on I-91
Job Location: Along I-91

Information about Prevailing Wage Schedules for Awarding Authorities and Contractors

- The wage rates will remain in effect for the duration of the project, except in the case of multi-year public construction projects. For construction projects lasting longer than one year, awarding authorities must request an updated wage schedule no later than two weeks before the anniversary of the date the contract was executed by the awarding authority and the general contractor. For multi-year CM AT RISK projects, the awarding authority must request an annual update no later than two weeks before the anniversary date, determined as the earlier of: (a) the execution date of the GMP Amendment, or (b) the execution date of the first amendment to permit procurement of construction services. The updated wage schedule must be provided to all contractors, including general and sub-contractors, working on the construction project.
- This annual update requirement is generally not applicable to 27F "rental of equipment" contracts. For such contracts, the prevailing wage rates issued by DLS shall remain in effect for the duration of the contract term. However, if the prevailing wage rate sheet issued does not contain wage rates for each year covered by the contract term, the Awarding Authority must request updated rate sheets from DLS and provide them to the contractor to ensure the correct rates are being paid throughout the duration of the contract. Additionally, if an Awarding Authority exercises an option to renew or extend the contract term, they must request updated rate sheets from DLS and provide them to the contractor.
- This wage schedule applies only to the specific project referenced at the top of this page and uniquely identified by the "Wage Request Number" on all pages of this schedule.
- An Awarding Authority must request an updated wage schedule if it has not opened bids or selected a contractor within 90 days of the date of issuance of the wage schedule. For CM AT RISK projects (bid pursuant to G.L. c.149A), the earlier of: (a) the execution date of the GMP Amendment, or (b) the bid for the first construction scope of work must be within 90-days of the wage schedule issuance date.
- The wage schedule shall be incorporated in any advertisement or call for bids for the project as required by M.G.L. c. 149, § 27. The wage schedule shall be made a part of the contract awarded for the project. The wage schedule must be posted in a conspicuous place at the work site for the life of the project in accordance with M.G.L. c. 149 § 27. The wages listed on the wage schedule must be paid to employees performing construction work on the project whether they are employed by the prime contractor, a filed sub-bidder, or a sub-contractor.
- Apprentices working on the project are required to be registered with the Massachusetts Division of Apprentice Standards (DAS). Apprentices must keep their apprentice identification card on their persons during all work hours on the project. An apprentice registered with DAS may be paid the lower apprentice wage rate at the applicable step as provided on the prevailing wage schedule. **Any apprentice not registered with DAS regardless of whether they are registered with another federal, state, local, or private agency must be paid the journeyworker's rate.**
- Every contractor or subcontractor working on the construction project must submit weekly payroll reports and a Statement of Compliance directly to the awarding authority by mail or email and keep them on file for three years. Each weekly payroll report must contain: the employee's name, address, occupational classification, hours worked, and wages paid. Do not submit weekly payroll reports to DLS. For a sample payroll reporting form go to <http://www.mass.gov/dols/pw>.
- Contractors with questions about the wage rates or classifications included on the wage schedule have an affirmative obligation to inquire with DLS at (617) 626-6953.
- Contractors must obtain the wage schedules from awarding authorities. Failure of a contractor or subcontractor to pay the prevailing wage rates listed on the wage schedule to all employees who perform construction work on the project is a violation of the law and subjects the contractor or subcontractor to civil and criminal penalties.
- Employees not receiving the prevailing wage rate set forth on the wage schedule may file a complaint with the Fair Labor Division of the office of the Attorney General at (617) 727-3465.

Issue Date: 12/27/2024

Wage Request Number: 20241227-016-2

Classification	Effective Date	Base Wage	Health	Pension	Supplemental Unemployment	Total Rate
Construction						
(2 AXLE) DRIVER - EQUIPMENT <i>TEAMSTERS JOINT COUNCIL NO. 10 ZONE B</i>	12/01/2024	\$39.95	\$15.07	\$20.17	\$0.00	\$75.19
	01/01/2025	\$39.95	\$15.57	\$20.17	\$0.00	\$75.69
	06/01/2025	\$40.95	\$15.57	\$20.17	\$0.00	\$76.69
	12/01/2025	\$40.95	\$15.57	\$21.78	\$0.00	\$78.30
	01/01/2026	\$40.95	\$16.17	\$21.78	\$0.00	\$78.90
	06/01/2026	\$41.95	\$16.17	\$21.78	\$0.00	\$79.90
	12/01/2026	\$41.95	\$16.17	\$23.52	\$0.00	\$81.64
	01/01/2027	\$41.95	\$16.77	\$23.52	\$0.00	\$82.24
(3 AXLE) DRIVER - EQUIPMENT <i>TEAMSTERS JOINT COUNCIL NO. 10 ZONE B</i>	12/01/2024	\$40.02	\$15.07	\$20.17	\$0.00	\$75.26
	01/01/2025	\$40.02	\$15.57	\$20.17	\$0.00	\$75.76
	06/01/2025	\$41.02	\$15.57	\$20.17	\$0.00	\$76.76
	12/01/2025	\$41.02	\$15.57	\$21.78	\$0.00	\$78.37
	01/01/2026	\$41.02	\$16.17	\$21.78	\$0.00	\$78.97
	06/01/2026	\$42.02	\$16.17	\$21.78	\$0.00	\$79.97
	12/01/2026	\$42.02	\$16.17	\$23.52	\$0.00	\$81.71
	01/01/2027	\$42.02	\$16.77	\$23.52	\$0.00	\$82.31
(4 & 5 AXLE) DRIVER - EQUIPMENT <i>TEAMSTERS JOINT COUNCIL NO. 10 ZONE B</i>	12/01/2024	\$40.14	\$15.07	\$20.17	\$0.00	\$75.38
	01/01/2025	\$40.14	\$15.57	\$20.17	\$0.00	\$75.88
	06/01/2025	\$41.14	\$15.57	\$20.17	\$0.00	\$76.88
	12/01/2025	\$41.14	\$15.57	\$21.78	\$0.00	\$78.49
	01/01/2026	\$41.14	\$16.17	\$21.78	\$0.00	\$79.09
	06/01/2026	\$42.14	\$16.17	\$21.78	\$0.00	\$80.09
	12/01/2026	\$42.14	\$16.17	\$23.52	\$0.00	\$81.83
	01/01/2027	\$42.14	\$16.77	\$23.52	\$0.00	\$82.43
ADS/SUBMERSIBLE PILOT <i>PILE DRIVER LOCAL 56 (ZONE 3)</i>	08/01/2024	\$117.16	\$10.08	\$24.29	\$0.00	\$151.53
For apprentice rates see "Apprentice- PILE DRIVER"						
AIR TRACK OPERATOR <i>LABORERS - ZONE 3 (BUILDING & SITE)</i>	12/02/2024	\$36.50	\$9.65	\$17.07	\$0.00	\$63.22
	06/02/2025	\$37.75	\$9.65	\$17.07	\$0.00	\$64.47
	12/01/2025	\$39.00	\$9.65	\$17.07	\$0.00	\$65.72
	06/01/2026	\$40.30	\$9.65	\$17.07	\$0.00	\$67.02
	12/07/2026	\$41.60	\$9.65	\$17.07	\$0.00	\$68.32
	06/07/2027	\$43.00	\$9.65	\$17.07	\$0.00	\$69.72
	12/06/2027	\$44.40	\$9.65	\$17.07	\$0.00	\$71.12
	06/05/2028	\$45.90	\$9.65	\$17.07	\$0.00	\$72.62
For apprentice rates see "Apprentice- LABORER"						
AIR TRACK OPERATOR (HEAVY & HIGHWAY) <i>LABORERS - ZONE 3 (HEAVY & HIGHWAY)</i>	12/01/2024	\$36.50	\$9.65	\$15.06	\$0.00	\$61.21
	06/01/2025	\$37.75	\$9.65	\$15.06	\$0.00	\$62.46
	12/01/2025	\$38.99	\$9.65	\$15.06	\$0.00	\$63.70
	06/01/2026	\$40.29	\$9.65	\$15.06	\$0.00	\$65.00
	12/01/2026	\$41.58	\$9.65	\$15.06	\$0.00	\$66.29
For apprentice rates see "Apprentice- LABORER (Heavy and Highway)"						

Classification	Effective Date	Base Wage	Health	Pension	Supplemental Unemployment	Total Rate
ASBESTOS WORKER (PIPES & TANKS) <i>HEAT & FROST INSULATORS LOCAL 6 (SPRINGFIELD)</i>	12/01/2024	\$38.52	\$14.50	\$10.55	\$0.00	\$63.57
	06/01/2025	\$39.42	\$14.50	\$10.55	\$0.00	\$64.47
	12/01/2025	\$40.32	\$14.50	\$10.55	\$0.00	\$65.37
ASPHALT RAKER <i>LABORERS - ZONE 3 (BUILDING & SITE)</i>	12/02/2024	\$36.00	\$9.65	\$17.07	\$0.00	\$62.72
	06/02/2025	\$37.25	\$9.65	\$17.07	\$0.00	\$63.97
	12/01/2025	\$38.50	\$9.65	\$17.07	\$0.00	\$65.22
	06/01/2026	\$39.80	\$9.65	\$17.07	\$0.00	\$66.52
	12/07/2026	\$41.10	\$9.65	\$17.07	\$0.00	\$67.82
	06/07/2027	\$42.50	\$9.65	\$17.07	\$0.00	\$69.22
	12/06/2027	\$43.90	\$9.65	\$17.07	\$0.00	\$70.62
	06/05/2028	\$45.40	\$9.65	\$17.07	\$0.00	\$72.12
12/04/2028	\$46.90	\$9.65	\$17.07	\$0.00	\$73.62	
For apprentice rates see "Apprentice- LABORER"						
ASPHALT RAKER (HEAVY & HIGHWAY) <i>LABORERS - ZONE 3 (HEAVY & HIGHWAY)</i>	12/01/2024	\$36.00	\$9.65	\$15.06	\$0.00	\$60.71
	06/01/2025	\$37.25	\$9.65	\$15.06	\$0.00	\$61.96
	12/01/2025	\$38.49	\$9.65	\$15.06	\$0.00	\$63.20
	06/01/2026	\$39.79	\$9.65	\$15.06	\$0.00	\$64.50
	12/01/2026	\$41.08	\$9.65	\$15.06	\$0.00	\$65.79
For apprentice rates see "Apprentice- LABORER (Heavy and Highway)"						
AUTOMATIC GRADER-EXCAVATOR (RECLAIMER) <i>OPERATING ENGINEERS LOCAL 98</i>	12/01/2023	\$39.56	\$13.78	\$15.15	\$0.00	\$68.49
For apprentice rates see "Apprentice- OPERATING ENGINEERS"						
BACKHOE/FRONT-END LOADER OPERATOR <i>OPERATING ENGINEERS LOCAL 98</i>	12/01/2023	\$39.56	\$13.78	\$15.15	\$0.00	\$68.49
For apprentice rates see "Apprentice- OPERATING ENGINEERS"						
BARCO-TYPE JUMPING TAMPER <i>LABORERS - ZONE 3 (BUILDING & SITE)</i>	12/02/2024	\$36.00	\$9.65	\$17.07	\$0.00	\$62.72
	06/02/2025	\$37.25	\$9.65	\$17.07	\$0.00	\$63.97
	12/01/2025	\$38.50	\$9.65	\$17.07	\$0.00	\$65.22
	06/01/2026	\$39.80	\$9.65	\$17.07	\$0.00	\$66.52
	12/07/2026	\$41.10	\$9.65	\$17.07	\$0.00	\$67.82
	06/07/2027	\$42.50	\$9.65	\$17.07	\$0.00	\$69.22
	12/06/2027	\$43.90	\$9.65	\$17.07	\$0.00	\$70.62
	06/05/2028	\$45.40	\$9.65	\$17.07	\$0.00	\$72.12
12/04/2028	\$46.90	\$9.65	\$17.07	\$0.00	\$73.62	
For apprentice rates see "Apprentice- LABORER"						
BATCH/CEMENT PLANT - ON SITE <i>OPERATING ENGINEERS LOCAL 98</i>	12/01/2023	\$39.03	\$13.78	\$15.15	\$0.00	\$67.96
For apprentice rates see "Apprentice- OPERATING ENGINEERS"						
BLOCK PAVER, RAMMER / CURB SETTER <i>LABORERS - ZONE 3 (BUILDING & SITE)</i>	12/02/2024	\$36.50	\$9.65	\$17.07	\$0.00	\$63.22
	06/02/2025	\$37.75	\$9.65	\$17.07	\$0.00	\$64.47
	12/01/2025	\$39.00	\$9.65	\$17.07	\$0.00	\$65.72
	06/01/2026	\$40.30	\$9.65	\$17.07	\$0.00	\$67.02
	12/07/2026	\$41.60	\$9.65	\$17.07	\$0.00	\$68.32
	06/07/2027	\$43.00	\$9.65	\$17.07	\$0.00	\$69.72
	12/06/2027	\$44.40	\$9.65	\$17.07	\$0.00	\$71.12
	06/05/2028	\$45.90	\$9.65	\$17.07	\$0.00	\$72.62
12/04/2028	\$47.40	\$9.65	\$17.07	\$0.00	\$74.12	
For apprentice rates see "Apprentice- LABORER"						

Classification	Effective Date	Base Wage	Health	Pension	Supplemental Unemployment	Total Rate
BLOCK PAVER, RAMMER / CURB SETTER (HEAVY & HIGHWAY) <i>LABORERS - ZONE 3 (HEAVY & HIGHWAY)</i>	12/01/2024	\$36.50	\$9.65	\$15.06	\$0.00	\$61.21
	06/01/2025	\$37.75	\$9.65	\$15.06	\$0.00	\$62.46
	12/01/2025	\$38.99	\$9.65	\$15.06	\$0.00	\$63.70
	06/01/2026	\$40.29	\$9.65	\$15.06	\$0.00	\$65.00
	12/01/2026	\$41.58	\$9.65	\$15.06	\$0.00	\$66.29
For apprentice rates see "Apprentice- LABORER (Heavy and Highway)						
BOILER MAKER <i>BOILERMAKERS LOCAL 29</i>	01/01/2024	\$48.12	\$7.07	\$20.60	\$0.00	\$75.79

Apprentice - BOILERMAKER - Local 29

Effective Date - 01/01/2024

Step	percent	Apprentice Base Wage	Health	Pension	Supplemental Unemployment	Total Rate
1	65	\$31.28	\$7.07	\$13.22	\$0.00	\$51.57
2	65	\$31.28	\$7.07	\$13.22	\$0.00	\$51.57
3	70	\$33.68	\$7.07	\$14.23	\$0.00	\$54.98
4	75	\$36.09	\$7.07	\$15.24	\$0.00	\$58.40
5	80	\$38.50	\$7.07	\$16.25	\$0.00	\$61.82
6	85	\$40.90	\$7.07	\$17.28	\$0.00	\$65.25
7	90	\$43.31	\$7.07	\$18.28	\$0.00	\$68.66
8	95	\$45.71	\$7.07	\$19.32	\$0.00	\$72.10

Notes:

Apprentice to Journeyworker Ratio:1:4

BRICK/STONE/ARTIFICIAL MASONRY (INCL. MASONRY WATERPROOFING) <i>BRICKLAYERS LOCAL 3 (SPRINGFIELD/PITTSFIELD)</i>	08/01/2024	\$52.06	\$11.49	\$21.46	\$0.00	\$85.01
	02/01/2025	\$53.36	\$11.49	\$21.46	\$0.00	\$86.31
	08/01/2025	\$55.51	\$11.49	\$21.46	\$0.00	\$88.46
	02/01/2026	\$56.86	\$11.49	\$21.46	\$0.00	\$89.81
	08/01/2026	\$59.06	\$11.49	\$21.46	\$0.00	\$92.01
	02/01/2027	\$60.46	\$11.49	\$21.46	\$0.00	\$93.41

Classification	Effective Date	Base Wage	Health	Pension	Supplemental Unemployment	Total Rate
-----------------------	-----------------------	------------------	---------------	----------------	----------------------------------	-------------------

Apprentice - BRICK/PLASTER/CEMENT MASON - Local 3 Springfield/Pittsfield

Effective Date - 08/01/2024

Step	percent	Apprentice Base Wage	Health	Pension	Supplemental Unemployment	Total Rate
1	50	\$26.03	\$11.49	\$21.46	\$0.00	\$58.98
2	60	\$31.24	\$11.49	\$21.46	\$0.00	\$64.19
3	70	\$36.44	\$11.49	\$21.46	\$0.00	\$69.39
4	80	\$41.65	\$11.49	\$21.46	\$0.00	\$74.60
5	90	\$46.85	\$11.49	\$21.46	\$0.00	\$79.80

Effective Date - 02/01/2025

Step	percent	Apprentice Base Wage	Health	Pension	Supplemental Unemployment	Total Rate
1	50	\$26.68	\$11.49	\$21.46	\$0.00	\$59.63
2	60	\$32.02	\$11.49	\$21.46	\$0.00	\$64.97
3	70	\$37.35	\$11.49	\$21.46	\$0.00	\$70.30
4	80	\$42.69	\$11.49	\$21.46	\$0.00	\$75.64
5	90	\$48.02	\$11.49	\$21.46	\$0.00	\$80.97

Notes:

Apprentice to Journeyworker Ratio:1:5

BULLDOZER/POWER SHOVEL/TREE SHREDDER /CLAM SHELL OPERATING	12/01/2023	\$39.56	\$13.78	\$15.15	\$0.00	\$68.49
---	------------	---------	---------	---------	--------	---------

ENGINEERS LOCAL 98

For apprentice rates see "Apprentice- OPERATING ENGINEERS"

CAISSON & UNDERPINNING BOTTOM MAN LABORERS - FOUNDATION AND MARINE	12/01/2024	\$48.10	\$9.65	\$18.22	\$0.00	\$75.97
	06/01/2025	\$49.60	\$9.65	\$18.22	\$0.00	\$77.47
	12/01/2025	\$51.10	\$9.65	\$18.22	\$0.00	\$78.97
	06/01/2026	\$52.65	\$9.65	\$18.22	\$0.00	\$80.52
	12/01/2026	\$54.15	\$9.65	\$18.22	\$0.00	\$82.02

For apprentice rates see "Apprentice- LABORER"

CAISSON & UNDERPINNING LABORER LABORERS - FOUNDATION AND MARINE	12/01/2024	\$46.95	\$9.65	\$18.22	\$0.00	\$74.82
	06/01/2025	\$48.45	\$9.65	\$18.22	\$0.00	\$76.32
	12/01/2025	\$49.95	\$9.65	\$18.22	\$0.00	\$77.82
	06/01/2026	\$51.50	\$9.65	\$18.22	\$0.00	\$79.37
	12/01/2026	\$53.00	\$9.65	\$18.22	\$0.00	\$80.87

For apprentice rates see "Apprentice- LABORER"

CAISSON & UNDERPINNING TOP MAN LABORERS - FOUNDATION AND MARINE	12/01/2024	\$47.28	\$9.65	\$18.22	\$0.00	\$75.15
	06/01/2025	\$48.78	\$9.65	\$18.22	\$0.00	\$76.65
	12/01/2025	\$50.28	\$9.65	\$18.22	\$0.00	\$78.15
	06/01/2026	\$51.83	\$9.65	\$18.22	\$0.00	\$79.70
	12/01/2026	\$53.33	\$9.65	\$18.22	\$0.00	\$81.20

For apprentice rates see "Apprentice- LABORER"

Classification	Effective Date	Base Wage	Health	Pension	Supplemental Unemployment	Total Rate
CARBIDE CORE DRILL OPERATOR <i>LABORERS - ZONE 3 (BUILDING & SITE)</i>	12/02/2024	\$36.00	\$9.65	\$17.07	\$0.00	\$62.72
	06/02/2025	\$37.25	\$9.65	\$17.07	\$0.00	\$63.97
	12/01/2025	\$38.50	\$9.65	\$17.07	\$0.00	\$65.22
	06/01/2026	\$39.80	\$9.65	\$17.07	\$0.00	\$66.52
	12/07/2026	\$41.10	\$9.65	\$17.07	\$0.00	\$67.82
	06/07/2027	\$42.50	\$9.65	\$17.07	\$0.00	\$69.22
	12/06/2027	\$43.90	\$9.65	\$17.07	\$0.00	\$70.62
	06/05/2028	\$45.40	\$9.65	\$17.07	\$0.00	\$72.12
	12/04/2028	\$46.90	\$9.65	\$17.07	\$0.00	\$73.62

For apprentice rates see "Apprentice- LABORER"

CARPENTER <i>CARPENTERS LOCAL 336 - HAMPDEN HAMPSHIRE FRANKLIN</i>	09/01/2024	\$42.36	\$7.91	\$18.15	\$0.00	\$68.42
	03/01/2025	\$43.26	\$7.91	\$18.15	\$0.00	\$69.32
	09/01/2025	\$44.21	\$7.91	\$18.15	\$0.00	\$70.27
	03/01/2026	\$45.11	\$7.91	\$18.15	\$0.00	\$71.17
	09/01/2026	\$46.06	\$7.91	\$18.15	\$0.00	\$72.12
	03/01/2027	\$46.96	\$7.91	\$18.15	\$0.00	\$73.02

Apprentice - CARPENTER - Local 336 Hampden Hampshire Franklin

Effective Date - 09/01/2024

Step	percent	Apprentice Base Wage	Health	Pension	Supplemental Unemployment	Total Rate
1	45	\$19.06	\$7.91	\$1.40	\$0.00	\$28.37
2	45	\$19.06	\$7.91	\$1.40	\$0.00	\$28.37
3	55	\$23.30	\$7.91	\$2.76	\$0.00	\$33.97
4	55	\$23.30	\$7.91	\$2.76	\$0.00	\$33.97
5	70	\$29.65	\$7.91	\$15.39	\$0.00	\$52.95
6	70	\$29.65	\$7.91	\$15.39	\$0.00	\$52.95
7	80	\$33.89	\$7.91	\$16.77	\$0.00	\$58.57
8	80	\$33.89	\$7.91	\$16.77	\$0.00	\$58.57

Effective Date - 03/01/2025

Step	percent	Apprentice Base Wage	Health	Pension	Supplemental Unemployment	Total Rate
1	45	\$19.47	\$7.91	\$1.40	\$0.00	\$28.78
2	45	\$19.47	\$7.91	\$1.40	\$0.00	\$28.78
3	55	\$23.79	\$7.91	\$2.76	\$0.00	\$34.46
4	55	\$23.79	\$7.91	\$2.76	\$0.00	\$34.46
5	70	\$30.28	\$7.91	\$15.39	\$0.00	\$53.58
6	70	\$30.28	\$7.91	\$15.39	\$0.00	\$53.58
7	80	\$34.61	\$7.91	\$16.77	\$0.00	\$59.29
8	80	\$34.61	\$7.91	\$16.77	\$0.00	\$59.29

Notes:

Apprentice to Journeyworker Ratio:1:5

Classification	Effective Date	Base Wage	Health	Pension	Supplemental Unemployment	Total Rate
CARPENTER WOOD FRAME	10/01/2024	\$26.65	\$7.02	\$4.80	\$0.00	\$38.47
<i>CARPENTERS-ZONE 3 (Wood Frame)</i>	10/01/2025	\$27.75	\$7.02	\$4.80	\$0.00	\$39.57
	10/01/2026	\$28.85	\$7.02	\$4.80	\$0.00	\$40.67

All Aspects of New Wood Frame Work

Apprentice - CARPENTER (Wood Frame) - Zone 3

Effective Date - 10/01/2024

Step	percent	Apprentice Base Wage	Health	Pension	Supplemental Unemployment	Total Rate
1	60	\$15.99	\$7.02	\$0.00	\$0.00	\$23.01
2	60	\$15.99	\$7.02	\$0.00	\$0.00	\$23.01
3	65	\$17.32	\$7.02	\$1.00	\$0.00	\$25.34
4	70	\$18.66	\$7.02	\$1.00	\$0.00	\$26.68
5	75	\$19.99	\$7.02	\$4.80	\$0.00	\$31.81
6	80	\$21.32	\$7.02	\$4.80	\$0.00	\$33.14
7	85	\$22.65	\$7.02	\$4.80	\$0.00	\$34.47
8	90	\$23.99	\$7.02	\$4.80	\$0.00	\$35.81

Effective Date - 10/01/2025

Step	percent	Apprentice Base Wage	Health	Pension	Supplemental Unemployment	Total Rate
1	60	\$16.65	\$7.02	\$0.00	\$0.00	\$23.67
2	60	\$16.65	\$7.02	\$0.00	\$0.00	\$23.67
3	65	\$18.04	\$7.02	\$1.00	\$0.00	\$26.06
4	70	\$19.43	\$7.02	\$1.00	\$0.00	\$27.45
5	75	\$20.81	\$7.02	\$4.80	\$0.00	\$32.63
6	80	\$22.20	\$7.02	\$4.80	\$0.00	\$34.02
7	85	\$23.59	\$7.02	\$4.80	\$0.00	\$35.41
8	90	\$24.98	\$7.02	\$4.80	\$0.00	\$36.80

Notes:

Apprentice to Journeyworker Ratio:1:5

CEMENT MASONRY/PLASTERING	01/01/2024	\$44.68	\$12.90	\$18.66	\$1.25	\$77.49
<i>BRICKLAYERS LOCAL 3 (SPRINGFIELD/PITTSFIELD)</i>						

Classification	Effective Date	Base Wage	Health	Pension	Supplemental Unemployment	Total Rate
-----------------------	-----------------------	------------------	---------------	----------------	----------------------------------	-------------------

Apprentice - CEMENT MASONRY/PLASTERING - Springfield/Pittsfield

Effective Date - 01/01/2024

Step	percent	Apprentice Base Wage	Health	Pension	Supplemental Unemployment	Total Rate
1	50	\$22.34	\$12.90	\$15.86	\$0.00	\$51.10
2	60	\$26.81	\$12.90	\$18.66	\$1.25	\$59.62
3	65	\$29.04	\$12.90	\$18.66	\$1.25	\$61.85
4	70	\$31.28	\$12.90	\$18.66	\$1.25	\$64.09
5	75	\$33.51	\$12.90	\$18.66	\$1.25	\$66.32
6	80	\$35.74	\$12.90	\$18.66	\$1.25	\$68.55
7	90	\$40.21	\$12.90	\$18.66	\$1.25	\$73.02

Notes:

Steps 3,4 are 500 hrs. All other steps are 1,000 hrs.

Apprentice to Journeyworker Ratio:1:3

CHAIN SAW OPERATOR <i>LABORERS - ZONE 3 (BUILDING & SITE)</i>	12/02/2024	\$36.00	\$9.65	\$17.07	\$0.00	\$62.72
	06/02/2025	\$37.25	\$9.65	\$17.07	\$0.00	\$63.97
	12/01/2025	\$38.50	\$9.65	\$17.07	\$0.00	\$65.22
	06/01/2026	\$39.80	\$9.65	\$17.07	\$0.00	\$66.52
	12/07/2026	\$41.10	\$9.65	\$17.07	\$0.00	\$67.82
	06/07/2027	\$42.50	\$9.65	\$17.07	\$0.00	\$69.22
	12/06/2027	\$43.90	\$9.65	\$17.07	\$0.00	\$70.62
	06/05/2028	\$45.40	\$9.65	\$17.07	\$0.00	\$72.12
	12/04/2028	\$46.90	\$9.65	\$17.07	\$0.00	\$73.62

For apprentice rates see "Apprentice- LABORER"

COMPRESSOR OPERATOR <i>OPERATING ENGINEERS LOCAL 98</i>	12/01/2023	\$39.03	\$13.78	\$15.15	\$0.00	\$67.96
---	------------	---------	---------	---------	--------	---------

For apprentice rates see "Apprentice- OPERATING ENGINEERS"

CRANE OPERATOR <i>OPERATING ENGINEERS LOCAL 98</i>	12/01/2023	\$43.06	\$13.78	\$15.15	\$0.00	\$71.99
--	------------	---------	---------	---------	--------	---------

For apprentice rates see "Apprentice- OPERATING ENGINEERS"

DELEADER (BRIDGE) <i>PAINTERS LOCAL 35 - ZONE 3</i>	07/01/2024	\$57.26	\$9.95	\$23.95	\$0.00	\$91.16
	01/01/2025	\$58.46	\$9.95	\$23.95	\$0.00	\$92.36

Classification **Effective Date** **Base Wage** **Health** **Pension** **Supplemental Unemployment** **Total Rate**

Apprentice - PAINTER Local 35 - BRIDGES/TANKS

Effective Date - 07/01/2024

Step	percent	Apprentice Base Wage	Health	Pension	Supplemental Unemployment	Total Rate
1	50	\$28.63	\$9.95	\$0.00	\$0.00	\$38.58
2	55	\$31.49	\$9.95	\$6.66	\$0.00	\$48.10
3	60	\$34.36	\$9.95	\$7.26	\$0.00	\$51.57
4	65	\$37.22	\$9.95	\$7.87	\$0.00	\$55.04
5	70	\$40.08	\$9.95	\$20.32	\$0.00	\$70.35
6	75	\$42.95	\$9.95	\$20.93	\$0.00	\$73.83
7	80	\$45.81	\$9.95	\$21.53	\$0.00	\$77.29
8	90	\$51.53	\$9.95	\$22.74	\$0.00	\$84.22

Effective Date - 01/01/2025

Step	percent	Apprentice Base Wage	Health	Pension	Supplemental Unemployment	Total Rate
1	50	\$29.23	\$9.95	\$0.00	\$0.00	\$39.18
2	55	\$32.15	\$9.95	\$6.66	\$0.00	\$48.76
3	60	\$35.08	\$9.95	\$7.26	\$0.00	\$52.29
4	65	\$38.00	\$9.95	\$7.87	\$0.00	\$55.82
5	70	\$40.92	\$9.95	\$20.32	\$0.00	\$71.19
6	75	\$43.85	\$9.95	\$20.93	\$0.00	\$74.73
7	80	\$46.77	\$9.95	\$21.53	\$0.00	\$78.25
8	90	\$52.61	\$9.95	\$22.74	\$0.00	\$85.30

Notes:

Steps are 750 hrs.

Apprentice to Journeyworker Ratio:1:1

DEMO: ADZEMAN	12/02/2024	\$47.00	\$9.65	\$18.40	\$0.00	\$75.05
LABORERS - ZONE 3 (BUILDING & SITE)	06/02/2025	\$48.50	\$9.65	\$18.40	\$0.00	\$76.55
	12/01/2025	\$50.00	\$9.65	\$18.40	\$0.00	\$78.05
	06/01/2026	\$51.55	\$9.65	\$18.40	\$0.00	\$79.60
	12/07/2026	\$53.05	\$9.65	\$18.40	\$0.00	\$81.10
	06/07/2027	\$54.65	\$9.65	\$18.40	\$0.00	\$82.70
	12/06/2027	\$56.25	\$9.65	\$18.40	\$0.00	\$84.30
	06/05/2028	\$57.93	\$9.65	\$18.40	\$0.00	\$85.98
	12/04/2028	\$59.60	\$9.65	\$18.40	\$0.00	\$87.65

For apprentice rates see "Apprentice- LABORER"

Classification	Effective Date	Base Wage	Health	Pension	Supplemental Unemployment	Total Rate
DEMO: BACKHOE/LOADER/HAMMER OPERATOR <i>LABORERS - ZONE 3 (BUILDING & SITE)</i>	12/02/2024	\$48.00	\$9.65	\$18.40	\$0.00	\$76.05
	06/02/2025	\$49.50	\$9.65	\$18.40	\$0.00	\$77.55
	12/01/2025	\$51.00	\$9.65	\$18.40	\$0.00	\$79.05
	06/01/2026	\$52.55	\$9.65	\$18.40	\$0.00	\$80.60
	12/07/2026	\$54.05	\$9.65	\$18.40	\$0.00	\$82.10
	06/07/2027	\$55.65	\$9.65	\$18.40	\$0.00	\$83.70
	12/06/2027	\$57.25	\$9.65	\$18.40	\$0.00	\$85.30
	06/05/2028	\$58.93	\$9.65	\$18.40	\$0.00	\$86.98
	12/04/2028	\$60.60	\$9.65	\$18.40	\$0.00	\$88.65
For apprentice rates see "Apprentice- LABORER"						
DEMO: BURNERS <i>LABORERS - ZONE 3 (BUILDING & SITE)</i>	12/02/2024	\$47.75	\$9.65	\$18.40	\$0.00	\$75.80
	06/02/2025	\$49.25	\$9.65	\$18.40	\$0.00	\$77.30
	12/01/2025	\$50.75	\$9.65	\$18.40	\$0.00	\$78.80
	06/01/2026	\$52.30	\$9.65	\$18.40	\$0.00	\$80.35
	12/07/2026	\$53.80	\$9.65	\$18.40	\$0.00	\$81.85
	06/07/2027	\$55.40	\$9.65	\$18.40	\$0.00	\$83.45
	12/06/2027	\$57.00	\$9.65	\$18.40	\$0.00	\$85.05
	06/05/2028	\$58.68	\$9.65	\$18.40	\$0.00	\$86.73
	12/04/2028	\$60.35	\$9.65	\$18.40	\$0.00	\$88.40
For apprentice rates see "Apprentice- LABORER"						
DEMO: CONCRETE CUTTER/SAWYER <i>LABORERS - ZONE 3 (BUILDING & SITE)</i>	12/02/2024	\$48.00	\$9.65	\$18.40	\$0.00	\$76.05
	06/02/2025	\$49.50	\$9.65	\$18.40	\$0.00	\$77.55
	12/01/2025	\$51.00	\$9.65	\$18.40	\$0.00	\$79.05
	06/01/2026	\$52.55	\$9.65	\$18.40	\$0.00	\$80.60
	12/07/2026	\$54.05	\$9.65	\$18.40	\$0.00	\$82.10
	06/07/2027	\$55.65	\$9.65	\$18.40	\$0.00	\$83.70
	12/06/2027	\$57.25	\$9.65	\$18.40	\$0.00	\$85.30
	06/05/2028	\$58.93	\$9.65	\$18.40	\$0.00	\$86.98
	12/04/2028	\$60.60	\$9.65	\$18.40	\$0.00	\$88.65
For apprentice rates see "Apprentice- LABORER"						
DEMO: JACKHAMMER OPERATOR <i>LABORERS - ZONE 3 (BUILDING & SITE)</i>	12/02/2024	\$47.75	\$9.65	\$18.40	\$0.00	\$75.80
	06/02/2025	\$49.25	\$9.65	\$18.40	\$0.00	\$77.30
	12/01/2025	\$50.75	\$9.65	\$18.40	\$0.00	\$78.80
	06/01/2026	\$52.30	\$9.65	\$18.40	\$0.00	\$80.35
	12/07/2026	\$53.80	\$9.65	\$18.40	\$0.00	\$81.85
	06/07/2027	\$55.40	\$9.65	\$18.40	\$0.00	\$83.45
	12/06/2027	\$57.00	\$9.65	\$18.40	\$0.00	\$85.05
	06/05/2028	\$58.68	\$9.65	\$18.40	\$0.00	\$86.73
	12/04/2028	\$60.35	\$9.65	\$18.40	\$0.00	\$88.40
For apprentice rates see "Apprentice- LABORER"						

Classification	Effective Date	Base Wage	Health	Pension	Supplemental Unemployment	Total Rate
DEMO: WRECKING LABORER <i>LABORERS - ZONE 3 (BUILDING & SITE)</i>	12/02/2024	\$47.00	\$9.65	\$18.40	\$0.00	\$75.05
	06/02/2025	\$48.50	\$9.65	\$18.40	\$0.00	\$76.55
	12/01/2025	\$50.00	\$9.65	\$18.40	\$0.00	\$78.05
	06/01/2026	\$51.55	\$9.65	\$18.40	\$0.00	\$79.60
	12/07/2026	\$53.05	\$9.65	\$18.40	\$0.00	\$81.10
	06/07/2027	\$54.65	\$9.65	\$18.40	\$0.00	\$82.70
	12/06/2027	\$56.25	\$9.65	\$18.40	\$0.00	\$84.30
	06/05/2028	\$57.93	\$9.65	\$18.40	\$0.00	\$85.98
	12/04/2028	\$59.60	\$9.65	\$18.40	\$0.00	\$87.65
For apprentice rates see "Apprentice- LABORER"						
DIVER <i>PILE DRIVER LOCAL 56 (ZONE 3)</i>	08/01/2024	\$78.11	\$10.08	\$24.29	\$0.00	\$112.48
as of 8-1-24, Apprentices with diving licenses begin at second year. % of Diver wage 70/80/90 2A \$69.83, 3A \$91.79,4A \$102.14 Total Rate						
DIVER TENDER <i>PILE DRIVER LOCAL 56 (ZONE 3)</i>	08/01/2024	\$49.19	\$10.08	\$24.29	\$0.00	\$83.56
as of 8-1-24, Apprentices with diving licenses begin at second year. % of Piledriver wage 70/80/90 2A \$54.20, 3A \$73.93,4A \$82.05 Total Rate						
DIVER TENDER (EFFLUENT) <i>PILE DRIVER LOCAL 56 (ZONE 3)</i>	08/01/2024	\$83.69	\$10.08	\$24.29	\$0.00	\$118.06
For apprentice rates see "Apprentice- PILE DRIVER"						
DIVER/SLURRY (EFFLUENT) <i>PILE DRIVER LOCAL 56 (ZONE 3)</i>	08/01/2024	\$117.16	\$10.08	\$24.29	\$0.00	\$151.53
For apprentice rates see "Apprentice- PILE DRIVER"						
DRAWBRIDGE OPERATOR (Construction) <i>DRAWBRIDGE - SEIU LOCAL 888</i>	07/01/2020	\$26.77	\$6.67	\$3.93	\$0.16	\$37.53
ELECTRICIAN (Including Core Drilling) <i>ELECTRICIANS LOCAL 7</i>	06/30/2024	\$50.01	\$13.00	\$14.86	\$0.00	\$77.87
	12/29/2024	\$51.06	\$13.25	\$15.06	\$0.00	\$79.37
	06/29/2025	\$52.16	\$13.50	\$15.21	\$0.00	\$80.87
	12/28/2025	\$53.26	\$13.75	\$15.36	\$0.00	\$82.37
	06/28/2026	\$54.41	\$14.00	\$15.46	\$0.00	\$83.87
	01/03/2027	\$55.56	\$14.25	\$15.56	\$0.00	\$85.37

Classification

Effective Date Base Wage Health Pension Supplemental Unemployment Total Rate

Apprentice - ELECTRICIAN - Local 7

Effective Date - 06/30/2024

Step	percent	Apprentice Base Wage	Health	Pension	Supplemental Unemployment	Total Rate
1	40	\$20.00	\$7.20	\$0.60	\$0.00	\$27.80
2	45	\$22.50	\$7.20	\$0.68	\$0.00	\$30.38
3	50	\$25.01	\$13.00	\$7.40	\$0.00	\$45.41
4	55	\$27.51	\$13.00	\$7.48	\$0.00	\$47.99
5	65	\$32.51	\$13.00	\$9.64	\$0.00	\$55.15
6	70	\$35.01	\$13.00	\$11.06	\$0.00	\$59.07

Effective Date - 12/29/2024

Step	percent	Apprentice Base Wage	Health	Pension	Supplemental Unemployment	Total Rate
1	40	\$20.42	\$7.35	\$0.61	\$0.00	\$28.38
2	45	\$22.98	\$7.35	\$0.69	\$0.00	\$31.02
3	50	\$25.53	\$13.25	\$7.47	\$0.00	\$46.25
4	55	\$28.08	\$13.25	\$7.54	\$0.00	\$48.87
5	65	\$33.19	\$13.25	\$9.74	\$0.00	\$56.18
6	70	\$35.74	\$13.25	\$11.19	\$0.00	\$60.18

Notes:

Steps 1-2 are 1000 hrs; Steps 3-6 are 1500 hrs.

Apprentice to Journeyworker Ratio:2:3****

ELEVATOR CONSTRUCTOR	01/01/2024	\$61.98	\$16.18	\$20.96	\$0.00	\$99.12
ELEVATOR CONSTRUCTORS LOCAL 41	01/01/2025	\$62.83	\$16.28	\$21.36	\$0.00	\$100.47
	01/01/2026	\$63.68	\$16.38	\$21.76	\$0.00	\$101.82
	01/01/2027	\$64.53	\$16.48	\$22.16	\$0.00	\$103.17

Classification	Effective Date	Base Wage	Health	Pension	Supplemental Unemployment	Total Rate
-----------------------	-----------------------	------------------	---------------	----------------	----------------------------------	-------------------

Apprentice - ELEVATOR CONSTRUCTOR - Local 41

Effective Date - 01/01/2024

Step	percent	Apprentice Base Wage	Health	Pension	Supplemental Unemployment	Total Rate
1	50	\$30.99	\$16.18	\$0.00	\$0.00	\$47.17
2	55	\$34.09	\$16.18	\$20.96	\$0.00	\$71.23
3	65	\$40.29	\$16.18	\$20.96	\$0.00	\$77.43
4	70	\$43.39	\$16.18	\$20.96	\$0.00	\$80.53
5	80	\$49.58	\$16.18	\$20.96	\$0.00	\$86.72

Effective Date - 01/01/2025

Step	percent	Apprentice Base Wage	Health	Pension	Supplemental Unemployment	Total Rate
1	50	\$31.42	\$16.28	\$0.00	\$0.00	\$47.70
2	55	\$34.56	\$16.28	\$21.36	\$0.00	\$72.20
3	65	\$40.84	\$16.28	\$21.36	\$0.00	\$78.48
4	70	\$43.98	\$16.28	\$21.36	\$0.00	\$81.62
5	80	\$50.26	\$16.28	\$21.36	\$0.00	\$87.90

Notes:

Steps 1-2 are 6 mos.; Steps 3-5 are 1 year

Apprentice to Journeyworker Ratio:1:1

ELEVATOR CONSTRUCTOR HELPER <i>ELEVATOR CONSTRUCTORS LOCAL 41</i>	01/01/2024	\$43.39	\$16.18	\$20.96	\$0.00	\$80.53
	01/01/2025	\$43.98	\$16.28	\$21.36	\$0.00	\$81.62
	01/01/2026	\$44.58	\$16.38	\$21.76	\$0.00	\$82.72
	01/01/2027	\$45.17	\$16.48	\$22.16	\$0.00	\$83.81

For apprentice rates see "Apprentice - ELEVATOR CONSTRUCTOR"

FENCE & GUARD RAIL ERECTOR (HEAVY & HIGHWAY) <i>LABORERS - ZONE 3 (HEAVY & HIGHWAY)</i>	12/01/2024	\$36.00	\$9.65	\$15.06	\$0.00	\$60.71
	06/01/2025	\$37.25	\$9.65	\$15.06	\$0.00	\$61.96
	12/01/2025	\$38.49	\$9.65	\$15.06	\$0.00	\$63.20
	06/01/2026	\$39.79	\$9.65	\$15.06	\$0.00	\$64.50
	12/01/2026	\$41.08	\$9.65	\$15.06	\$0.00	\$65.79

For apprentice rates see "Apprentice- LABORER (Heavy and Highway)"

FIELD ENG.INST/ROD-BLDG,SITE,HVY/HWY <i>OPERATING ENGINEERS LOCAL 98</i>	06/01/1999	\$18.84	\$4.80	\$4.10	\$0.00	\$27.74
---	------------	---------	--------	--------	--------	---------

FIELD ENG.PARTY CHIEF:BLDG,SITE,HVY/HWY <i>OPERATING ENGINEERS LOCAL 98</i>	06/01/1999	\$21.33	\$4.80	\$4.10	\$0.00	\$30.23
--	------------	---------	--------	--------	--------	---------

FIELD ENG.SURVEY CHIEF-BLDG,SITE,HVY/HWY <i>OPERATING ENGINEERS LOCAL 98</i>	06/01/1999	\$22.33	\$4.80	\$4.10	\$0.00	\$31.23
---	------------	---------	--------	--------	--------	---------

FIRE ALARM INSTALLER <i>ELECTRICIANS LOCAL 7</i>	06/30/2024	\$50.01	\$13.00	\$14.86	\$0.00	\$77.87
	12/29/2024	\$51.06	\$13.25	\$15.06	\$0.00	\$79.37
	06/29/2025	\$52.16	\$13.50	\$15.21	\$0.00	\$80.87
	12/28/2025	\$53.26	\$13.75	\$15.36	\$0.00	\$82.37
	06/28/2026	\$54.41	\$14.00	\$15.46	\$0.00	\$83.87
	01/03/2027	\$55.56	\$14.25	\$15.56	\$0.00	\$85.37

For apprentice rates see "Apprentice- ELECTRICIAN"

Classification	Effective Date	Base Wage	Health	Pension	Supplemental Unemployment	Total Rate
FIRE ALARM REPAIR / MAINTENANCE / COMMISSIONING <i>ELECTRICIANS</i>	06/30/2024	\$50.01	\$13.00	\$14.86	\$0.00	\$77.87
<i>LOCAL 7</i>	12/29/2024	\$51.06	\$13.25	\$15.06	\$0.00	\$79.37
	06/29/2025	\$52.16	\$13.50	\$15.21	\$0.00	\$80.87
	12/28/2025	\$53.26	\$13.75	\$15.36	\$0.00	\$82.37
	06/28/2026	\$54.41	\$14.00	\$15.46	\$0.00	\$83.87
	01/03/2027	\$55.56	\$14.25	\$15.56	\$0.00	\$85.37
For apprentice rates see "Apprentice- TELECOMMUNICATIONS TECHNICIAN"						
FIREMAN <i>OPERATING ENGINEERS LOCAL 98</i>	12/01/2023	\$39.03	\$13.78	\$15.15	\$0.00	\$67.96

Apprentice - OPERATING ENGINEERS - Local 98 Class 3

Effective Date - 12/01/2023

Step	percent	Apprentice Base Wage	Health	Pension	Supplemental Unemployment	Total Rate
1	60	\$23.42	\$13.78	\$15.15	\$0.00	\$52.35
2	70	\$27.32	\$13.78	\$15.15	\$0.00	\$56.25
3	80	\$31.22	\$13.78	\$15.15	\$0.00	\$60.15
4	90	\$35.13	\$13.78	\$15.15	\$0.00	\$64.06

Notes:

Steps 1-2 are 1000 hrs.; Steps 3-4 are 2000 hrs.

Apprentice to Journeyworker Ratio:1:6

FLAGGER & SIGNALER (HEAVY & HIGHWAY) <i>LABORERS - ZONE 3 (HEAVY & HIGHWAY)</i>	12/01/2024	\$27.01	\$9.65	\$15.06	\$0.00	\$51.72
	06/01/2025	\$28.09	\$9.65	\$15.06	\$0.00	\$52.80
	12/01/2025	\$28.09	\$9.65	\$15.06	\$0.00	\$52.80
	06/01/2026	\$29.21	\$9.65	\$15.06	\$0.00	\$53.92
	12/01/2026	\$29.21	\$9.65	\$15.06	\$0.00	\$53.92
For apprentice rates see "Apprentice- LABORER (Heavy and Highway)"						
FLOORCOVERER <i>FLOORCOVERERS LOCAL 2168 ZONE III</i>	09/01/2024	\$42.36	\$7.91	\$18.15	\$0.00	\$68.42
	03/01/2025	\$43.26	\$7.91	\$18.15	\$0.00	\$69.32
	09/01/2025	\$44.21	\$7.91	\$18.15	\$0.00	\$70.27
	03/01/2026	\$45.11	\$7.91	\$18.15	\$0.00	\$71.17
	09/01/2026	\$46.06	\$7.91	\$18.15	\$0.00	\$72.12
	03/01/2027	\$46.96	\$7.91	\$18.15	\$0.00	\$73.02

Classification	Effective Date	Base Wage	Health	Pension	Supplemental Unemployment	Total Rate
-----------------------	-----------------------	------------------	---------------	----------------	----------------------------------	-------------------

Apprentice - FLOORCOVERER - Local 2168 Zone III

Effective Date - 09/01/2024

Step	percent	Apprentice Base Wage	Health	Pension	Supplemental Unemployment	Total Rate
1	50	\$21.18	\$7.91	\$1.38	\$0.00	\$30.47
2	55	\$23.30	\$7.91	\$1.38	\$0.00	\$32.59
3	60	\$25.42	\$7.91	\$2.76	\$0.00	\$36.09
4	65	\$27.53	\$7.91	\$2.76	\$0.00	\$38.20
5	70	\$29.65	\$7.91	\$15.39	\$0.00	\$52.95
6	75	\$31.77	\$7.91	\$15.39	\$0.00	\$55.07
7	80	\$33.89	\$7.91	\$16.77	\$0.00	\$58.57
8	85	\$36.01	\$7.91	\$16.77	\$0.00	\$60.69

Effective Date - 03/01/2025

Step	percent	Apprentice Base Wage	Health	Pension	Supplemental Unemployment	Total Rate
1	50	\$21.63	\$7.91	\$1.38	\$0.00	\$30.92
2	55	\$23.79	\$7.91	\$1.38	\$0.00	\$33.08
3	60	\$25.96	\$7.91	\$2.76	\$0.00	\$36.63
4	65	\$28.12	\$7.91	\$2.76	\$0.00	\$38.79
5	70	\$30.28	\$7.91	\$15.39	\$0.00	\$53.58
6	75	\$32.45	\$7.91	\$15.39	\$0.00	\$55.75
7	80	\$34.61	\$7.91	\$16.77	\$0.00	\$59.29
8	85	\$36.77	\$7.91	\$16.77	\$0.00	\$61.45

Notes: Steps are 750 hrs.
 % After 10/1/17; 45/45/55/55/70/70/80/80 (1500hr Steps)
 Step 1&2 \$26.72.24/ 3&4 \$32.11/ 5&6 \$50.75/ 7&8 \$56.14

Apprentice to Journeyworker Ratio:1:1

FORK LIFT <i>OPERATING ENGINEERS LOCAL 98</i>	12/01/2023	\$39.25	\$13.78	\$15.15	\$0.00	\$68.18
---	------------	---------	---------	---------	--------	---------

For apprentice rates see "Apprentice- OPERATING ENGINEERS"

GENERATORS/LIGHTING PLANTS <i>OPERATING ENGINEERS LOCAL 98</i>	12/01/2023	\$35.80	\$13.78	\$15.15	\$0.00	\$64.73
--	------------	---------	---------	---------	--------	---------

For apprentice rates see "Apprentice- OPERATING ENGINEERS"

GLAZIER (GLASS PLANK/AIR BARRIER/INTERIOR SYSTEMS) <i>GLAZIERS LOCAL 1333</i>	06/01/2020	\$39.18	\$10.80	\$10.45	\$0.00	\$60.43
---	------------	---------	---------	---------	--------	---------

Classification	Effective Date	Base Wage	Health	Pension	Supplemental Unemployment	Total Rate
Apprentice - GLAZIER - Local 1333						
Effective Date - 06/01/2020						
Step	percent	Apprentice Base Wage	Health	Pension	Supplemental Unemployment	Total Rate
1	50	\$19.59	\$10.80	\$1.80	\$0.00	\$32.19
2	56	\$22.04	\$10.80	\$1.80	\$0.00	\$34.64
3	63	\$24.49	\$10.80	\$2.45	\$0.00	\$37.74
4	69	\$26.94	\$10.80	\$2.45	\$0.00	\$40.19
5	75	\$29.39	\$10.80	\$3.15	\$0.00	\$43.34
6	81	\$31.83	\$10.80	\$3.15	\$0.00	\$45.78
7	88	\$34.28	\$10.80	\$10.45	\$0.00	\$55.53
8	94	\$36.73	\$10.80	\$10.45	\$0.00	\$57.98

Notes:

Apprentice to Journeyworker Ratio:1:3

GRADER/TRENCHING MACHINE/DERRICK <i>OPERATING ENGINEERS LOCAL 98</i>	12/01/2023	\$39.56	\$13.78	\$15.15	\$0.00	\$68.49
For apprentice rates see "Apprentice- OPERATING ENGINEERS"						
HVAC (DUCTWORK) <i>SHEETMETAL WORKERS LOCAL 63</i>	07/01/2024	\$40.98	\$12.20	\$18.74	\$2.13	\$74.05
	01/01/2025	\$42.23	\$12.20	\$18.74	\$2.13	\$75.30
For apprentice rates see "Apprentice- SHEET METAL WORKER"						
HVAC (ELECTRICAL CONTROLS) <i>ELECTRICIANS LOCAL 7</i>	06/30/2024	\$50.01	\$13.00	\$14.86	\$0.00	\$77.87
	12/29/2024	\$51.06	\$13.25	\$15.06	\$0.00	\$79.37
	06/29/2025	\$52.16	\$13.50	\$15.21	\$0.00	\$80.87
	12/28/2025	\$53.26	\$13.75	\$15.36	\$0.00	\$82.37
	06/28/2026	\$54.41	\$14.00	\$15.46	\$0.00	\$83.87
	01/03/2027	\$55.56	\$14.25	\$15.56	\$0.00	\$85.37
For apprentice rates see "Apprentice- ELECTRICIAN"						
HVAC (TESTING AND BALANCING - AIR) <i>SHEETMETAL WORKERS LOCAL 63</i>	07/01/2024	\$40.98	\$12.20	\$18.74	\$2.13	\$74.05
	01/01/2025	\$42.23	\$12.20	\$18.74	\$2.13	\$75.30
For apprentice rates see "Apprentice- SHEET METAL WORKER"						
HVAC (TESTING AND BALANCING - WATER) <i>PLUMBERS & PIPEFITTERS LOCAL 104</i>	03/17/2024	\$49.21	\$9.55	\$17.10	\$0.00	\$75.86
For apprentice rates see "Apprentice- PIPEFITTER" or "PLUMBER/PIPEFITTER"						
HVAC MECHANIC <i>PLUMBERS & PIPEFITTERS LOCAL 104</i>	03/17/2024	\$49.21	\$9.55	\$17.10	\$0.00	\$75.86
For apprentice rates see "Apprentice- PIPEFITTER" or "PLUMBER/PIPEFITTER"						
HYDRAULIC DRILLS (HEAVY & HIGHWAY) <i>LABORERS - ZONE 3 (HEAVY & HIGHWAY)</i>	12/01/2024	\$36.50	\$9.65	\$15.06	\$0.00	\$61.21
	06/01/2025	\$37.75	\$9.65	\$15.06	\$0.00	\$62.46
	12/01/2025	\$38.99	\$9.65	\$15.06	\$0.00	\$63.70
	06/01/2026	\$40.29	\$9.65	\$15.06	\$0.00	\$65.00
	12/01/2026	\$41.58	\$9.65	\$15.06	\$0.00	\$66.29
For apprentice rates see "Apprentice- LABORER (Heavy and Highway)"						

Classification	Effective Date	Base Wage	Health	Pension	Supplemental Unemployment	Total Rate
INSULATOR (PIPES & TANKS) <i>HEAT & FROST INSULATORS LOCAL 6 (SPRINGFIELD)</i>	09/01/2024	\$45.54	\$14.75	\$19.61	\$0.00	\$79.90
	09/01/2025	\$48.27	\$14.75	\$19.61	\$0.00	\$82.63
	09/01/2026	\$51.01	\$14.75	\$19.61	\$0.00	\$85.37

Apprentice - ASBESTOS INSULATOR (Pipes & Tanks) - Local 6 Springfield

Effective Date - 09/01/2024

Step	percent	Apprentice Base Wage	Health	Pension	Supplemental Unemployment	Total Rate
1	50	\$22.77	\$14.75	\$14.32	\$0.00	\$51.84
2	60	\$27.32	\$14.75	\$15.37	\$0.00	\$57.44
3	70	\$31.88	\$14.75	\$16.43	\$0.00	\$63.06
4	80	\$36.43	\$14.75	\$17.49	\$0.00	\$68.67

Effective Date - 09/01/2025

Step	percent	Apprentice Base Wage	Health	Pension	Supplemental Unemployment	Total Rate
1	50	\$24.14	\$14.75	\$14.32	\$0.00	\$53.21
2	60	\$28.96	\$14.75	\$15.37	\$0.00	\$59.08
3	70	\$33.79	\$14.75	\$16.43	\$0.00	\$64.97
4	80	\$38.62	\$14.75	\$17.49	\$0.00	\$70.86

Notes:

Steps are 1 year

Apprentice to Journeyworker Ratio:1:4

IRONWORKER/WELDER <i>IRONWORKERS LOCAL 7 (SPRINGFIELD AREA)</i>	03/16/2024	\$40.66	\$8.25	\$22.70	\$0.00	\$71.61
--	------------	---------	--------	---------	--------	---------

Apprentice - IRONWORKER - Local 7 Springfield

Effective Date - 03/16/2024

Step	percent	Apprentice Base Wage	Health	Pension	Supplemental Unemployment	Total Rate
1	60	\$24.40	\$8.25	\$22.70	\$0.00	\$55.35
2	70	\$28.46	\$8.25	\$22.70	\$0.00	\$59.41
3	75	\$30.50	\$8.25	\$22.70	\$0.00	\$61.45
4	80	\$32.53	\$8.25	\$22.70	\$0.00	\$63.48
5	85	\$34.56	\$8.25	\$22.70	\$0.00	\$65.51
6	90	\$36.59	\$8.25	\$22.70	\$0.00	\$67.54

Notes:

Apprentice to Journeyworker Ratio:1:4

Classification	Effective Date	Base Wage	Health	Pension	Supplemental Unemployment	Total Rate
JACKHAMMER & PAVING BREAKER OPERATOR <i>LABORERS - ZONE 3 (BUILDING & SITE)</i>	12/02/2024	\$36.00	\$9.65	\$17.07	\$0.00	\$62.72
	06/02/2025	\$37.25	\$9.65	\$17.07	\$0.00	\$63.97
	12/01/2025	\$38.50	\$9.65	\$17.07	\$0.00	\$65.22
	06/01/2026	\$39.80	\$9.65	\$17.07	\$0.00	\$66.52
	12/07/2026	\$41.10	\$9.65	\$17.07	\$0.00	\$67.82
	06/07/2027	\$42.50	\$9.65	\$17.07	\$0.00	\$69.22
	12/06/2027	\$43.90	\$9.65	\$17.07	\$0.00	\$70.62
	06/05/2028	\$45.40	\$9.65	\$17.07	\$0.00	\$72.12
	12/04/2028	\$46.90	\$9.65	\$17.07	\$0.00	\$73.62

For apprentice rates see "Apprentice- LABORER"

LABORER <i>LABORERS - ZONE 3 (BUILDING & SITE)</i>	12/02/2024	\$35.75	\$9.65	\$17.07	\$0.00	\$62.47
	06/02/2025	\$37.00	\$9.65	\$17.07	\$0.00	\$63.72
	12/01/2025	\$38.25	\$9.65	\$17.07	\$0.00	\$64.97
	06/01/2026	\$39.55	\$9.65	\$17.07	\$0.00	\$66.27
	12/07/2026	\$40.85	\$9.65	\$17.07	\$0.00	\$67.57
	06/07/2027	\$42.25	\$9.65	\$17.07	\$0.00	\$68.97
	12/06/2027	\$43.65	\$9.65	\$17.07	\$0.00	\$70.37
	06/05/2028	\$45.15	\$9.65	\$17.07	\$0.00	\$71.87
	12/04/2028	\$46.65	\$9.65	\$17.07	\$0.00	\$73.37

Apprentice - LABORER - Zone 3 Building & Site

Effective Date - 12/02/2024

Step	percent	Apprentice Base Wage	Health	Pension	Supplemental Unemployment	Total Rate
1	60	\$21.45	\$9.65	\$17.07	\$0.00	\$48.17
2	70	\$25.03	\$9.65	\$17.07	\$0.00	\$51.75
3	80	\$28.60	\$9.65	\$17.07	\$0.00	\$55.32
4	90	\$32.18	\$9.65	\$17.07	\$0.00	\$58.90

Effective Date - 06/02/2025

Step	percent	Apprentice Base Wage	Health	Pension	Supplemental Unemployment	Total Rate
1	60	\$22.20	\$9.65	\$17.07	\$0.00	\$48.92
2	70	\$25.90	\$9.65	\$17.07	\$0.00	\$52.62
3	80	\$29.60	\$9.65	\$17.07	\$0.00	\$56.32
4	90	\$33.30	\$9.65	\$17.07	\$0.00	\$60.02

Notes:

Apprentice to Journeyworker Ratio:1:5

LABORER (HEAVY & HIGHWAY) <i>LABORERS - ZONE 3 (HEAVY & HIGHWAY)</i>	12/01/2024	\$35.75	\$9.65	\$15.06	\$0.00	\$60.46
	06/01/2025	\$37.00	\$9.65	\$15.06	\$0.00	\$61.71
	12/01/2025	\$38.24	\$9.65	\$15.06	\$0.00	\$62.95
	06/01/2026	\$39.54	\$9.65	\$15.06	\$0.00	\$64.25
	12/01/2026	\$40.83	\$9.65	\$15.06	\$0.00	\$65.54

Classification	Effective Date	Base Wage	Health	Pension	Supplemental Unemployment	Total Rate
LABORER: HAZARDOUS WASTE/ASBESTOS REMOVER <i>LABORERS - ZONE 3 (BUILDING & SITE)</i>	12/02/2024	\$35.67	\$9.65	\$17.20	\$0.00	\$62.52
	06/02/2025	\$36.92	\$9.65	\$17.20	\$0.00	\$63.77
	12/01/2025	\$38.17	\$9.65	\$17.20	\$0.00	\$65.02
	06/01/2026	\$39.47	\$9.65	\$17.20	\$0.00	\$66.32
	12/07/2026	\$40.77	\$9.65	\$17.20	\$0.00	\$67.62
	06/07/2027	\$42.17	\$9.65	\$17.20	\$0.00	\$69.02
	12/06/2027	\$43.57	\$9.65	\$17.20	\$0.00	\$70.42
	06/05/2028	\$45.07	\$9.65	\$17.20	\$0.00	\$71.92
	12/04/2028	\$46.57	\$9.65	\$17.20	\$0.00	\$73.42
For apprentice rates see "Apprentice- LABORER"						
LABORER: MASON TENDER <i>LABORERS - ZONE 3 (BUILDING & SITE)</i>	12/02/2024	\$38.75	\$9.65	\$17.07	\$0.00	\$65.47
	06/02/2025	\$40.00	\$9.65	\$17.07	\$0.00	\$66.72
	12/01/2025	\$41.25	\$9.65	\$17.07	\$0.00	\$67.97
	06/01/2026	\$42.55	\$9.65	\$17.07	\$0.00	\$69.27
	12/07/2026	\$43.85	\$9.65	\$17.07	\$0.00	\$70.57
	06/07/2027	\$45.25	\$9.65	\$17.07	\$0.00	\$71.97
	12/06/2027	\$46.65	\$9.65	\$17.07	\$0.00	\$73.37
	06/05/2028	\$48.15	\$9.65	\$17.07	\$0.00	\$74.87
	12/04/2028	\$49.65	\$9.65	\$17.07	\$0.00	\$76.37
For apprentice rates see "Apprentice- LABORER"						
LABORER: MASON TENDER (HEAVY & HIGHWAY) <i>LABORERS - ZONE 3 (HEAVY & HIGHWAY)</i>	12/01/2024	\$36.00	\$9.65	\$15.06	\$0.00	\$60.71
	06/01/2025	\$37.25	\$9.65	\$15.06	\$0.00	\$61.96
	12/01/2025	\$38.49	\$9.65	\$15.06	\$0.00	\$63.20
	06/01/2026	\$39.79	\$9.65	\$15.06	\$0.00	\$64.50
	12/01/2026	\$41.08	\$9.65	\$15.06	\$0.00	\$65.79
For apprentice rates see "Apprentice- LABORER (Heavy and Highway)"						
LABORER: MULTI-TRADE TENDER <i>LABORERS - ZONE 3 (BUILDING & SITE)</i>	12/02/2024	\$35.75	\$9.65	\$17.07	\$0.00	\$62.47
	06/02/2025	\$37.00	\$9.65	\$17.07	\$0.00	\$63.72
	12/01/2025	\$38.25	\$9.65	\$17.07	\$0.00	\$64.97
	06/01/2026	\$39.55	\$9.65	\$17.07	\$0.00	\$66.27
	12/07/2026	\$40.85	\$9.65	\$17.07	\$0.00	\$67.57
	06/07/2027	\$42.25	\$9.65	\$17.07	\$0.00	\$68.97
	12/06/2027	\$43.65	\$9.65	\$17.07	\$0.00	\$70.37
	06/05/2028	\$45.15	\$9.65	\$17.07	\$0.00	\$71.87
	12/04/2028	\$46.65	\$9.65	\$17.07	\$0.00	\$73.37
For apprentice rates see "Apprentice- LABORER"						
LABORER: TREE REMOVER <i>LABORERS - ZONE 3 (BUILDING & SITE)</i>	12/02/2024	\$35.75	\$9.65	\$17.07	\$0.00	\$62.47
	06/02/2025	\$37.00	\$9.65	\$17.07	\$0.00	\$63.72
	12/01/2025	\$38.25	\$9.65	\$17.07	\$0.00	\$64.97
	06/01/2026	\$39.55	\$9.65	\$17.07	\$0.00	\$66.27
	12/07/2026	\$40.85	\$9.65	\$17.07	\$0.00	\$67.57
	06/07/2027	\$42.25	\$9.65	\$17.07	\$0.00	\$68.97
	12/06/2027	\$43.65	\$9.65	\$17.07	\$0.00	\$70.37
	06/05/2028	\$45.15	\$9.65	\$17.07	\$0.00	\$71.87
	12/04/2028	\$46.65	\$9.65	\$17.07	\$0.00	\$73.37

This classification applies to the removal of standing trees, and the trimming and removal of branches and limbs when related to public works construction or site clearance incidental to construction . For apprentice rates see "Apprentice- LABORER"

Classification	Effective Date	Base Wage	Health	Pension	Supplemental Unemployment	Total Rate
LASER BEAM OPERATOR <i>LABORERS - ZONE 3 (BUILDING & SITE)</i>	12/02/2024	\$36.00	\$9.65	\$17.07	\$0.00	\$62.72
	06/02/2025	\$37.25	\$9.65	\$17.07	\$0.00	\$63.97
	12/01/2025	\$38.50	\$9.65	\$17.07	\$0.00	\$65.22
	06/01/2026	\$39.80	\$9.65	\$17.07	\$0.00	\$66.52
	12/07/2026	\$41.10	\$9.65	\$17.07	\$0.00	\$67.82
	06/07/2027	\$42.50	\$9.65	\$17.07	\$0.00	\$69.22
	12/06/2027	\$43.90	\$9.65	\$17.07	\$0.00	\$70.62
	06/05/2028	\$45.40	\$9.65	\$17.07	\$0.00	\$72.12
	12/04/2028	\$46.90	\$9.65	\$17.07	\$0.00	\$73.62

For apprentice rates see "Apprentice- LABORER"

LASER BEAM OPERATOR (HEAVY & HIGHWAY) <i>LABORERS - ZONE 3 (HEAVY & HIGHWAY)</i>	12/01/2024	\$36.00	\$9.65	\$15.06	\$0.00	\$60.71
	06/01/2025	\$37.25	\$9.65	\$15.06	\$0.00	\$61.96
	12/01/2025	\$38.49	\$9.65	\$15.06	\$0.00	\$63.20
	06/01/2026	\$39.79	\$9.65	\$15.06	\$0.00	\$64.50
	12/01/2026	\$41.08	\$9.65	\$15.06	\$0.00	\$65.79

For apprentice rates see "Apprentice- LABORER (Heavy and Highway)"

MARBLE & TILE FINISHERS <i>BRICKLAYERS LOCAL 3 (SPR/PITT) - MARBLE & TILE</i>	08/01/2024	\$43.05	\$11.49	\$20.53	\$0.00	\$75.07
	02/01/2025	\$44.90	\$11.49	\$20.53	\$0.00	\$76.92
	08/01/2025	\$45.81	\$11.49	\$20.53	\$0.00	\$77.83
	02/01/2026	\$46.89	\$11.49	\$20.53	\$0.00	\$78.91
	08/01/2026	\$48.65	\$11.49	\$20.53	\$0.00	\$80.67
	02/01/2027	\$49.77	\$11.49	\$20.53	\$0.00	\$81.79

Apprentice - MARBLE-TILE FINISHER-Local 3 Marble/Tile (Spr/Pitt)

Effective Date - 08/01/2024

Step	percent	Apprentice Base Wage	Health	Pension	Supplemental Unemployment	Total Rate
1	50	\$21.53	\$11.49	\$20.53	\$0.00	\$53.55
2	60	\$25.83	\$11.49	\$20.53	\$0.00	\$57.85
3	70	\$30.14	\$11.49	\$20.53	\$0.00	\$62.16
4	80	\$34.44	\$11.49	\$20.53	\$0.00	\$66.46
5	90	\$38.75	\$11.49	\$20.53	\$0.00	\$70.77

Effective Date - 02/01/2025

Step	percent	Apprentice Base Wage	Health	Pension	Supplemental Unemployment	Total Rate
1	50	\$22.45	\$11.49	\$20.53	\$0.00	\$54.47
2	60	\$26.94	\$11.49	\$20.53	\$0.00	\$58.96
3	70	\$31.43	\$11.49	\$20.53	\$0.00	\$63.45
4	80	\$35.92	\$11.49	\$20.53	\$0.00	\$67.94
5	90	\$40.41	\$11.49	\$20.53	\$0.00	\$72.43

Notes:

Apprentice to Journeyworker Ratio:1:5

MARBLE MASON/TILE LAYER(SP/PT)SeeBrick
BRICKLAYERS LOCAL 3 (SPR/PITT) - MARBLE & TILE

Classification	Effective Date	Base Wage	Health	Pension	Supplemental Unemployment	Total Rate
See "BRICK/STONE/ARTIFICIAL MASONRY(INCL.MASONRY WATERPROOFING)						
MECH. SWEEPER OPERATOR (ON CONST. SITES) <i>OPERATING ENGINEERS LOCAL 98</i>	12/01/2023	\$39.56	\$13.78	\$15.15	\$0.00	\$68.49
For apprentice rates see "Apprentice- OPERATING ENGINEERS"						
MECHANIC/WELDER/BOOM TRUCK <i>OPERATING ENGINEERS LOCAL 98</i>	12/01/2023	\$39.03	\$13.78	\$15.15	\$0.00	\$67.96
For apprentice rates see "Apprentice- OPERATING ENGINEERS"						
MILLWRIGHT (Zone 3) <i>MILLWRIGHTS LOCAL 1121 - Zone 3</i>	01/01/2024	\$41.20	\$10.08	\$21.22	\$0.00	\$72.50
	01/06/2025	\$43.48	\$10.08	\$21.22	\$0.00	\$74.78
	01/05/2026	\$45.76	\$10.08	\$21.22	\$0.00	\$77.06

Apprentice - MILLWRIGHT - Local 1121 Zone 3

Effective Date - 01/01/2024

Step	percent	Apprentice Base Wage	Health	Pension	Supplemental Unemployment	Total Rate
1	55	\$22.66	\$10.08	\$5.36	\$0.00	\$38.10
2	65	\$26.78	\$10.08	\$6.34	\$0.00	\$43.20
3	75	\$30.90	\$10.08	\$18.78	\$0.00	\$59.76
4	85	\$35.02	\$10.08	\$19.76	\$0.00	\$64.86

Effective Date - 01/06/2025

Step	percent	Apprentice Base Wage	Health	Pension	Supplemental Unemployment	Total Rate
1	55	\$23.91	\$10.08	\$5.36	\$0.00	\$39.35
2	65	\$28.26	\$10.08	\$6.34	\$0.00	\$44.68
3	75	\$32.61	\$10.08	\$18.78	\$0.00	\$61.47
4	85	\$36.96	\$10.08	\$19.76	\$0.00	\$66.80

Notes: Step 1&2 Appr. indentured after 1/6/2020 receive no pension, but do receive annuity. (Step 1 \$5.72, Step 2 \$6.66)
Steps are 2,000 hours

Apprentice to Journeyworker Ratio:1:4

MORTAR MIXER <i>LABORERS - ZONE 3 (BUILDING & SITE)</i>	12/02/2024	\$36.00	\$9.65	\$17.07	\$0.00	\$62.72
	06/02/2025	\$37.25	\$9.65	\$17.07	\$0.00	\$63.97
	12/01/2025	\$38.50	\$9.65	\$17.07	\$0.00	\$65.22
	06/01/2026	\$39.80	\$9.65	\$17.07	\$0.00	\$66.52
	12/07/2026	\$41.10	\$9.65	\$17.07	\$0.00	\$67.82
	06/07/2027	\$42.50	\$9.65	\$17.07	\$0.00	\$69.22
	12/06/2027	\$43.90	\$9.65	\$17.07	\$0.00	\$70.62
	06/05/2028	\$45.40	\$9.65	\$17.07	\$0.00	\$72.12
	12/04/2028	\$46.90	\$9.65	\$17.07	\$0.00	\$73.62
For apprentice rates see "Apprentice- LABORER"						
OILER <i>OPERATING ENGINEERS LOCAL 98</i>	12/01/2023	\$35.02	\$13.78	\$15.15	\$0.00	\$63.95
For apprentice rates see "Apprentice- OPERATING ENGINEERS"						
OTHER POWER DRIVEN EQUIPMENT - CLASS VI <i>OPERATING ENGINEERS LOCAL 98</i>	12/01/2023	\$32.74	\$13.78	\$15.15	\$0.00	\$61.67
For apprentice rates see "Apprentice- OPERATING ENGINEERS"						
Painter (BRIDGES/TANKS) <i>PAINTERS LOCAL 35 - ZONE 3</i>	07/01/2024	\$57.26	\$9.95	\$23.95	\$0.00	\$91.16
	01/01/2025	\$58.46	\$9.95	\$23.95	\$0.00	\$92.36

Classification **Effective Date** **Base Wage** **Health** **Pension** **Supplemental Unemployment** **Total Rate**

Apprentice - PAINTER Local 35 - BRIDGES/TANKS

Effective Date - 07/01/2024

Step	percent	Apprentice Base Wage	Health	Pension	Supplemental Unemployment	Total Rate
1	50	\$28.63	\$9.95	\$0.00	\$0.00	\$38.58
2	55	\$31.49	\$9.95	\$6.66	\$0.00	\$48.10
3	60	\$34.36	\$9.95	\$7.26	\$0.00	\$51.57
4	65	\$37.22	\$9.95	\$7.87	\$0.00	\$55.04
5	70	\$40.08	\$9.95	\$20.32	\$0.00	\$70.35
6	75	\$42.95	\$9.95	\$20.93	\$0.00	\$73.83
7	80	\$45.81	\$9.95	\$21.53	\$0.00	\$77.29
8	90	\$51.53	\$9.95	\$22.74	\$0.00	\$84.22

Effective Date - 01/01/2025

Step	percent	Apprentice Base Wage	Health	Pension	Supplemental Unemployment	Total Rate
1	50	\$29.23	\$9.95	\$0.00	\$0.00	\$39.18
2	55	\$32.15	\$9.95	\$6.66	\$0.00	\$48.76
3	60	\$35.08	\$9.95	\$7.26	\$0.00	\$52.29
4	65	\$38.00	\$9.95	\$7.87	\$0.00	\$55.82
5	70	\$40.92	\$9.95	\$20.32	\$0.00	\$71.19
6	75	\$43.85	\$9.95	\$20.93	\$0.00	\$74.73
7	80	\$46.77	\$9.95	\$21.53	\$0.00	\$78.25
8	90	\$52.61	\$9.95	\$22.74	\$0.00	\$85.30

Notes:

Steps are 750 hrs.

Apprentice to Journeyworker Ratio:1:1

PAINTER (SPRAY OR SANDBLAST, NEW) *	07/01/2024	\$40.03	\$9.65	\$19.90	\$0.00	\$69.58
* If 30% or more of surfaces to be painted are new construction, NEW paint rate shall be used. PAINTERS LOCAL 35 - ZONE 3	01/01/2025	\$41.23	\$9.65	\$19.90	\$0.00	\$70.78

Classification

Effective Date Base Wage Health Pension Supplemental Unemployment Total Rate

Apprentice - PAINTER Local 35 Zone 3 - Spray/Sandblast - New

Effective Date - 07/01/2024

Step	percent	Apprentice Base Wage	Health	Pension	Supplemental Unemployment	Total Rate
1	50	\$20.02	\$9.95	\$0.00	\$0.00	\$29.97
2	55	\$22.02	\$9.95	\$4.43	\$0.00	\$36.40
3	60	\$24.02	\$9.95	\$4.83	\$0.00	\$38.80
4	65	\$26.02	\$9.95	\$5.23	\$0.00	\$41.20
5	70	\$28.02	\$9.95	\$17.49	\$0.00	\$55.46
6	75	\$30.02	\$9.95	\$17.89	\$0.00	\$57.86
7	80	\$32.02	\$9.95	\$18.29	\$0.00	\$60.26
8	90	\$36.03	\$9.95	\$19.10	\$0.00	\$65.08

Effective Date - 01/01/2025

Step	percent	Apprentice Base Wage	Health	Pension	Supplemental Unemployment	Total Rate
1	50	\$20.62	\$9.95	\$0.00	\$0.00	\$30.57
2	55	\$22.68	\$9.95	\$4.43	\$0.00	\$37.06
3	60	\$24.74	\$9.95	\$4.83	\$0.00	\$39.52
4	65	\$26.80	\$9.95	\$5.23	\$0.00	\$41.98
5	70	\$28.86	\$9.95	\$17.49	\$0.00	\$56.30
6	75	\$30.92	\$9.95	\$17.89	\$0.00	\$58.76
7	80	\$32.98	\$9.95	\$18.29	\$0.00	\$61.22
8	90	\$37.11	\$9.95	\$19.10	\$0.00	\$66.16

Notes:

Steps are 750 hrs.

Apprentice to Journeyworker Ratio:1:1

PAINTER (SPRAY OR SANDBLAST, REPAINT)	07/01/2024	\$37.35	\$9.95	\$19.90	\$0.00	\$67.20
PAINTERS LOCAL 35 - ZONE 3	01/01/2025	\$38.55	\$9.95	\$19.90	\$0.00	\$68.40

Classification

Effective Date Base Wage Health Pension Supplemental Unemployment Total Rate

Apprentice - PAINTER - Local 35 Zone 3 - BRUSH NEW

Effective Date - 07/01/2024

Step	percent	Apprentice Base Wage	Health	Pension	Supplemental Unemployment	Total Rate
1	50	\$19.32	\$9.95	\$0.00	\$0.00	\$29.27
2	55	\$21.25	\$9.95	\$4.43	\$0.00	\$35.63
3	60	\$23.18	\$9.95	\$4.83	\$0.00	\$37.96
4	65	\$25.11	\$9.95	\$5.23	\$0.00	\$40.29
5	70	\$27.04	\$9.95	\$17.49	\$0.00	\$54.48
6	75	\$28.97	\$9.95	\$17.89	\$0.00	\$56.81
7	80	\$30.90	\$9.95	\$18.29	\$0.00	\$59.14
8	90	\$34.77	\$9.95	\$19.10	\$0.00	\$63.82

Effective Date - 01/01/2025

Step	percent	Apprentice Base Wage	Health	Pension	Supplemental Unemployment	Total Rate
1	50	\$19.92	\$9.95	\$0.00	\$0.00	\$29.87
2	55	\$21.91	\$9.95	\$4.43	\$0.00	\$36.29
3	60	\$23.90	\$9.95	\$4.83	\$0.00	\$38.68
4	65	\$25.89	\$9.95	\$5.23	\$0.00	\$41.07
5	70	\$27.88	\$9.95	\$17.49	\$0.00	\$55.32
6	75	\$29.87	\$9.95	\$17.89	\$0.00	\$57.71
7	80	\$31.86	\$9.95	\$18.29	\$0.00	\$60.10
8	90	\$35.85	\$9.95	\$19.10	\$0.00	\$64.90

Notes:

Steps are 750 hrs.

Apprentice to Journeyworker Ratio:1:1

PAINTER / TAPER (BRUSH, REPAINT)	07/01/2024	\$35.95	\$9.95	\$19.90	\$0.00	\$65.80
PAINTERS LOCAL 35 - ZONE 3	01/01/2025	\$37.15	\$9.95	\$19.90	\$0.00	\$67.00

Classification **Effective Date** **Base Wage** **Health** **Pension** **Supplemental Unemployment** **Total Rate**

Apprentice - PAINTER Local 35 Zone 3 - BRUSH REPAINT

Effective Date - 07/01/2024

Step	percent	Apprentice Base Wage	Health	Pension	Supplemental Unemployment	Total Rate
1	50	\$17.98	\$9.95	\$0.00	\$0.00	\$27.93
2	55	\$19.77	\$9.95	\$4.43	\$0.00	\$34.15
3	60	\$21.57	\$9.95	\$4.83	\$0.00	\$36.35
4	65	\$23.37	\$9.95	\$5.23	\$0.00	\$38.55
5	70	\$25.17	\$9.95	\$17.49	\$0.00	\$52.61
6	75	\$26.96	\$9.95	\$17.89	\$0.00	\$54.80
7	80	\$28.76	\$9.95	\$18.29	\$0.00	\$57.00
8	90	\$32.36	\$9.95	\$19.10	\$0.00	\$61.41

Effective Date - 01/01/2025

Step	percent	Apprentice Base Wage	Health	Pension	Supplemental Unemployment	Total Rate
1	50	\$18.58	\$9.95	\$0.00	\$0.00	\$28.53
2	55	\$20.43	\$9.95	\$4.43	\$0.00	\$34.81
3	60	\$22.29	\$9.95	\$4.83	\$0.00	\$37.07
4	65	\$24.15	\$9.95	\$5.23	\$0.00	\$39.33
5	70	\$26.01	\$9.95	\$17.49	\$0.00	\$53.45
6	75	\$27.86	\$9.95	\$17.89	\$0.00	\$55.70
7	80	\$29.72	\$9.95	\$18.29	\$0.00	\$57.96
8	90	\$33.44	\$9.95	\$19.10	\$0.00	\$62.49

Notes:

Steps are 750 hrs.

Apprentice to Journeyworker Ratio:1:1

PAINTER TRAFFIC MARKINGS (HEAVY/HIGHWAY)	12/01/2024	\$35.75	\$9.65	\$15.06	\$0.00	\$60.46
LABORERS - ZONE 3 (HEAVY & HIGHWAY)	06/01/2025	\$37.00	\$9.65	\$15.06	\$0.00	\$61.71
	12/01/2025	\$38.24	\$9.65	\$15.06	\$0.00	\$62.95
	06/01/2026	\$39.54	\$9.65	\$15.06	\$0.00	\$64.25
	12/01/2026	\$40.83	\$9.65	\$15.06	\$0.00	\$65.54

For apprentice rates see "Apprentice- LABORER (Heavy and Highway)

PANEL & PICKUP TRUCKS DRIVER	12/01/2024	\$39.78	\$15.07	\$20.17	\$0.00	\$75.02
TEAMSTERS JOINT COUNCIL NO. 10 ZONE B	01/01/2025	\$39.78	\$15.57	\$20.17	\$0.00	\$75.52
	06/01/2025	\$40.78	\$15.57	\$20.17	\$0.00	\$76.52
	12/01/2025	\$40.78	\$15.57	\$21.78	\$0.00	\$78.13
	01/01/2026	\$40.78	\$16.17	\$21.78	\$0.00	\$78.73
	06/01/2026	\$41.78	\$16.17	\$21.78	\$0.00	\$79.73
	12/01/2026	\$41.78	\$16.17	\$23.52	\$0.00	\$81.47
	01/01/2027	\$41.78	\$16.77	\$23.52	\$0.00	\$82.07

PIER AND DOCK CONSTRUCTOR (UNDERPINNING AND DECK)	08/01/2024	\$49.19	\$10.08	\$24.29	\$0.00	\$83.56
PILE DRIVER LOCAL 56 (ZONE 3)						

For apprentice rates see "Apprentice- PILE DRIVER"

Classification	Effective Date	Base Wage	Health	Pension	Supplemental Unemployment	Total Rate
PILE DRIVER <i>PILE DRIVER LOCAL 56 (ZONE 3)</i>	08/01/2024	\$49.19	\$10.08	\$24.29	\$0.00	\$83.56

Apprentice - PILE DRIVER - Local 56 Zone 3

Effective Date - 08/01/2024

Step	percent	Apprentice Base Wage	Health	Pension	Supplemental Unemployment	Total Rate
1	45	\$22.14	\$10.08	\$2.53	\$0.00	\$34.75
2	55	\$27.05	\$10.08	\$5.07	\$0.00	\$42.20
3	70	\$34.43	\$10.08	\$19.22	\$0.00	\$63.73
4	80	\$39.35	\$10.08	\$21.76	\$0.00	\$71.19

Notes:

% Indentured BEFORE 8/1/2020, 50/60/70/75/80/80/90/90
1\$58.97/2\$63.88/3\$68.80/4\$71.26/5&6 \$73.72/7&8 \$78.64

Apprentice to Journeyworker Ratio:1:5

PIPELAYER <i>LABORERS - ZONE 3 (BUILDING & SITE)</i>	12/02/2024	\$36.00	\$9.65	\$17.07	\$0.00	\$62.72
	06/02/2025	\$37.25	\$9.65	\$17.07	\$0.00	\$63.97
	12/01/2025	\$38.50	\$9.65	\$17.07	\$0.00	\$65.22
	06/01/2026	\$39.80	\$9.65	\$17.07	\$0.00	\$66.52
	12/07/2026	\$41.10	\$9.65	\$17.07	\$0.00	\$67.82
	06/07/2027	\$42.50	\$9.65	\$17.07	\$0.00	\$69.22
	12/06/2027	\$43.90	\$9.65	\$17.07	\$0.00	\$70.62
	06/05/2028	\$45.40	\$9.65	\$17.07	\$0.00	\$72.12
	12/04/2028	\$46.90	\$9.65	\$17.07	\$0.00	\$73.62

For apprentice rates see "Apprentice- LABORER"

PIPELAYER (HEAVY & HIGHWAY) <i>LABORERS - ZONE 3 (HEAVY & HIGHWAY)</i>	12/01/2024	\$36.00	\$9.65	\$15.06	\$0.00	\$60.71
	06/01/2025	\$37.25	\$9.65	\$15.06	\$0.00	\$61.96
	12/01/2025	\$38.49	\$9.65	\$15.06	\$0.00	\$63.20
	06/01/2026	\$39.79	\$9.65	\$15.06	\$0.00	\$64.50
	12/01/2026	\$41.08	\$9.65	\$15.06	\$0.00	\$65.79

For apprentice rates see "Apprentice- LABORER (Heavy and Highway)"

PLUMBER & PIPEFITTER <i>PLUMBERS & PIPEFITTERS LOCAL 104</i>	03/17/2024	\$49.21	\$9.55	\$17.10	\$0.00	\$75.86
---	------------	---------	--------	---------	--------	---------

Classification	Effective Date	Base Wage	Health	Pension	Supplemental Unemployment	Total Rate
Apprentice - PLUMBER/PIPEFITTER - Local 104						
Effective Date - 03/17/2024						
Step	percent	Apprentice Base Wage	Health	Pension	Supplemental Unemployment	Total Rate
1	45	\$22.14	\$9.55	\$10.10	\$0.00	\$41.79
2	50	\$24.61	\$9.55	\$10.10	\$0.00	\$44.26
3	55	\$27.07	\$9.55	\$10.10	\$0.00	\$46.72
4	60	\$29.53	\$9.55	\$10.10	\$0.00	\$49.18
5	65	\$31.99	\$9.55	\$10.10	\$0.00	\$51.64
6	70	\$34.45	\$9.55	\$10.10	\$0.00	\$54.10
7	75	\$36.91	\$9.55	\$10.10	\$0.00	\$56.56
8	80	\$39.37	\$9.55	\$10.10	\$0.00	\$59.02
9	80	\$39.37	\$9.55	\$17.10	\$0.00	\$66.02
10	80	\$39.37	\$9.55	\$17.10	\$0.00	\$66.02

Notes: **1:1,2:5,3:9,4:12

Apprentice to Journeyworker Ratio:**

PNEUMATIC CONTROLS (TEMP.) PLUMBERS & PIPEFITTERS LOCAL 104	03/17/2024	\$49.21	\$9.55	\$17.10	\$0.00	\$75.86
--	------------	---------	--------	---------	--------	---------

For apprentice rates see "Apprentice- PIPEFITTER" or "PLUMBER/PIPEFITTER"

PNEUMATIC DRILL/TOOL OPERATOR (HEAVY & HIGHWAY) LABORERS - ZONE 3 (HEAVY & HIGHWAY)	12/01/2024	\$36.00	\$9.65	\$15.06	\$0.00	\$60.71
	06/01/2025	\$37.25	\$9.65	\$15.06	\$0.00	\$61.96
	12/01/2025	\$38.49	\$9.65	\$15.06	\$0.00	\$63.20
	06/01/2026	\$39.79	\$9.65	\$15.06	\$0.00	\$64.50
	12/01/2026	\$41.08	\$9.65	\$15.06	\$0.00	\$65.79

For apprentice rates see "Apprentice- LABORER (Heavy and Highway)"

POWDERMAN & BLASTER LABORERS - ZONE 3 (BUILDING & SITE)	12/02/2024	\$36.75	\$9.65	\$17.07	\$0.00	\$63.47
	06/02/2025	\$38.00	\$9.65	\$17.07	\$0.00	\$64.72
	12/01/2025	\$39.25	\$9.65	\$17.07	\$0.00	\$65.97
	06/01/2026	\$40.55	\$9.65	\$17.07	\$0.00	\$67.27
	12/07/2026	\$41.85	\$9.65	\$17.07	\$0.00	\$68.57
	06/07/2027	\$43.25	\$9.65	\$17.07	\$0.00	\$69.97
	12/06/2027	\$44.65	\$9.65	\$17.07	\$0.00	\$71.37
	06/05/2028	\$46.15	\$9.65	\$17.07	\$0.00	\$72.87
	12/04/2028	\$47.65	\$9.65	\$17.07	\$0.00	\$74.37

For apprentice rates see "Apprentice- LABORER"

POWDERMAN & BLASTER (HEAVY & HIGHWAY) LABORERS - ZONE 3 (HEAVY & HIGHWAY)	12/01/2024	\$36.75	\$9.65	\$15.06	\$0.00	\$61.46
	06/01/2025	\$38.00	\$9.65	\$15.06	\$0.00	\$62.71
	12/01/2025	\$39.24	\$9.65	\$15.06	\$0.00	\$63.95
	06/01/2026	\$40.54	\$9.65	\$15.06	\$0.00	\$65.25
	12/01/2026	\$41.83	\$9.65	\$15.06	\$0.00	\$66.54

For apprentice rates see "Apprentice- LABORER (Heavy and Highway)"

PUMP OPERATOR (CONCRETE) OPERATING ENGINEERS LOCAL 98	12/01/2023	\$39.56	\$13.78	\$15.15	\$0.00	\$68.49
--	------------	---------	---------	---------	--------	---------

For apprentice rates see "Apprentice- OPERATING ENGINEERS"

Classification	Effective Date	Base Wage	Health	Pension	Supplemental Unemployment	Total Rate
PUMP OPERATOR (DEWATERING, OTHER) <i>OPERATING ENGINEERS LOCAL 98</i>	12/01/2023	\$39.03	\$13.78	\$15.15	\$0.00	\$67.96
For apprentice rates see "Apprentice- OPERATING ENGINEERS"						
READY-MIX CONCRETE DRIVER <i>TEAMSTERS 404 - Construction Service (Northampton)</i>	05/01/2024	\$26.14	\$11.82	\$7.25	\$0.00	\$45.21
RIDE-ON MOTORIZED BUGGY OPERATOR <i>LABORERS - ZONE 3 (BUILDING & SITE)</i>	12/02/2024	\$36.00	\$9.65	\$17.07	\$0.00	\$62.72
	06/02/2025	\$37.25	\$9.65	\$17.07	\$0.00	\$63.97
	12/01/2025	\$38.50	\$9.65	\$17.07	\$0.00	\$65.22
	06/01/2026	\$39.80	\$9.65	\$17.07	\$0.00	\$66.52
	12/07/2026	\$41.10	\$9.65	\$17.07	\$0.00	\$67.82
	06/07/2027	\$42.50	\$9.65	\$17.07	\$0.00	\$69.22
	12/06/2027	\$43.90	\$9.65	\$17.07	\$0.00	\$70.62
	06/05/2028	\$45.40	\$9.65	\$17.07	\$0.00	\$72.12
	12/04/2028	\$46.90	\$9.65	\$17.07	\$0.00	\$73.62
For apprentice rates see "Apprentice- LABORER"						
ROLLER OPERATOR <i>OPERATING ENGINEERS LOCAL 98</i>	12/01/2023	\$38.42	\$13.78	\$15.15	\$0.00	\$67.35
For apprentice rates see "Apprentice- OPERATING ENGINEERS"						
ROOFER (Coal tar pitch) <i>ROOFERS LOCAL 248</i>	10/02/2024	\$42.38	\$10.35	\$18.00	\$0.00	\$70.73
	07/16/2025	\$43.88	\$10.35	\$18.00	\$0.00	\$72.23
	10/02/2025	\$44.88	\$10.35	\$18.00	\$0.00	\$73.23
	07/16/2026	\$46.88	\$10.35	\$18.00	\$0.00	\$75.23
For apprentice rates see "Apprentice- ROOFER"						
ROOFER (Inc.Roofer Waterproofing &Roofer Damproofg) <i>ROOFERS LOCAL 248</i>	10/02/2024	\$41.88	\$10.35	\$18.00	\$0.00	\$70.23
	07/16/2025	\$43.38	\$10.35	\$18.00	\$0.00	\$71.73
	10/02/2025	\$44.38	\$10.35	\$18.00	\$0.00	\$72.73
	07/16/2026	\$46.38	\$10.35	\$18.00	\$0.00	\$74.73

Apprentice - ROOFER - Local 248

Effective Date - 10/02/2024

Step	percent	Apprentice Base Wage	Health	Pension	Supplemental Unemployment	Total Rate
1	60	\$25.13	\$10.35	\$0.00	\$0.00	\$35.48
2	65	\$27.22	\$10.35	\$18.00	\$0.00	\$55.57
3	70	\$29.32	\$10.35	\$18.00	\$0.00	\$57.67
4	75	\$31.41	\$10.35	\$18.00	\$0.00	\$59.76
5	80	\$33.50	\$10.35	\$18.00	\$0.00	\$61.85
6	85	\$35.60	\$10.35	\$18.00	\$0.00	\$63.95
7	90	\$37.69	\$10.35	\$18.00	\$0.00	\$66.04
8	95	\$39.79	\$10.35	\$18.00	\$0.00	\$68.14

Notes:

Steps are 750 hrs.Roofer(Tear Off)1:1; Same as above

Apprentice to Journeyworker Ratio:1:3

Classification	Effective Date	Base Wage	Health	Pension	Supplemental Unemployment	Total Rate
ROOFER SLATE / TILE / PRECAST CONCRETE <i>ROOFERS LOCAL 248</i>	10/02/2024	\$42.38	\$10.35	\$18.00	\$0.00	\$70.73
	07/16/2025	\$43.88	\$10.35	\$18.00	\$0.00	\$72.23
	10/02/2025	\$44.88	\$10.35	\$18.00	\$0.00	\$73.23
	07/16/2026	\$46.88	\$10.35	\$18.00	\$0.00	\$75.23
For apprentice rates see "Apprentice- ROOFER"						
SCRAPER <i>OPERATING ENGINEERS LOCAL 98</i>	12/01/2023	\$39.03	\$13.78	\$15.15	\$0.00	\$67.96
For apprentice rates see "Apprentice- OPERATING ENGINEERS"						
SELF-POWERED ROLLERS AND COMPACTORS (TAMPERS) <i>OPERATING ENGINEERS LOCAL 98</i>	12/01/2023	\$38.42	\$13.78	\$15.15	\$0.00	\$67.35
For apprentice rates see "Apprentice- OPERATING ENGINEERS"						
SELF-PROPELLED POWER BROOM <i>OPERATING ENGINEERS LOCAL 98</i>	12/01/2023	\$35.80	\$13.78	\$15.15	\$0.00	\$64.73
For apprentice rates see "Apprentice- OPERATING ENGINEERS"						
SHEETMETAL WORKER <i>SHEETMETAL WORKERS LOCAL 63</i>	07/01/2024	\$40.98	\$12.20	\$18.74	\$2.13	\$74.05
	01/01/2025	\$42.23	\$12.20	\$18.74	\$2.13	\$75.30

Classification

Effective Date Base Wage Health Pension Supplemental Unemployment Total Rate

Apprentice - SHEET METAL WORKER - Local 63

Effective Date - 07/01/2024

Step	percent	Apprentice Base Wage	Health	Pension	Supplemental Unemployment	Total Rate
1	45	\$18.44	\$5.49	\$4.86	\$0.85	\$29.64
2	50	\$20.49	\$6.10	\$5.40	\$0.94	\$32.93
3	55	\$22.54	\$6.71	\$9.71	\$1.15	\$40.11
4	60	\$24.59	\$7.32	\$9.71	\$1.23	\$42.85
5	65	\$26.64	\$7.93	\$9.71	\$1.31	\$45.59
6	70	\$28.69	\$8.54	\$9.71	\$1.39	\$48.33
7	75	\$30.74	\$9.15	\$9.71	\$1.47	\$51.07
8	80	\$32.78	\$9.76	\$17.66	\$1.78	\$61.98
9	85	\$34.83	\$10.37	\$17.66	\$1.86	\$64.72
10	90	\$36.88	\$10.98	\$17.66	\$1.94	\$67.46

Effective Date - 01/01/2025

Step	percent	Apprentice Base Wage	Health	Pension	Supplemental Unemployment	Total Rate
1	45	\$19.00	\$5.49	\$4.86	\$0.85	\$30.20
2	50	\$21.12	\$6.10	\$5.40	\$0.94	\$33.56
3	55	\$23.23	\$6.71	\$9.71	\$1.15	\$40.80
4	60	\$25.34	\$7.32	\$9.71	\$1.23	\$43.60
5	65	\$27.45	\$7.93	\$9.71	\$1.31	\$46.40
6	70	\$29.56	\$8.54	\$9.71	\$1.39	\$49.20
7	75	\$31.67	\$9.15	\$9.71	\$1.47	\$52.00
8	80	\$33.78	\$9.76	\$17.66	\$1.78	\$62.98
9	85	\$35.90	\$10.37	\$17.66	\$1.86	\$65.79
10	90	\$38.01	\$10.98	\$17.66	\$1.94	\$68.59

Notes:

Apprentice to Journeyworker Ratio:1:3

SPECIALIZED EARTH MOVING EQUIP < 35 TONS TEAMSTERS JOINT COUNCIL NO. 10 ZONE B	12/01/2024	\$40.24	\$15.07	\$20.17	\$0.00	\$75.48
	01/01/2025	\$40.24	\$15.57	\$20.17	\$0.00	\$75.98
	06/01/2025	\$41.24	\$15.57	\$20.17	\$0.00	\$76.98
	12/01/2025	\$41.24	\$15.57	\$21.78	\$0.00	\$78.59
	01/01/2026	\$41.24	\$16.17	\$21.78	\$0.00	\$79.19
	06/01/2026	\$42.24	\$16.17	\$21.78	\$0.00	\$80.19
	12/01/2026	\$42.24	\$16.17	\$23.52	\$0.00	\$81.93
	01/01/2027	\$42.24	\$16.77	\$23.52	\$0.00	\$82.53

Classification	Effective Date	Base Wage	Health	Pension	Supplemental Unemployment	Total Rate
SPECIALIZED EARTH MOVING EQUIP > 35 TONS <i>TEAMSTERS JOINT COUNCIL NO. 10 ZONE B</i>	12/01/2024	\$40.53	\$15.07	\$20.17	\$0.00	\$75.77
	01/01/2025	\$40.53	\$15.57	\$20.17	\$0.00	\$76.27
	06/01/2025	\$41.53	\$15.57	\$20.17	\$0.00	\$77.27
	12/01/2025	\$41.53	\$15.57	\$21.78	\$0.00	\$78.88
	01/01/2026	\$41.53	\$16.17	\$21.78	\$0.00	\$79.48
	06/01/2026	\$42.53	\$16.17	\$21.78	\$0.00	\$80.48
	12/01/2026	\$42.53	\$16.17	\$23.52	\$0.00	\$82.22
	01/01/2027	\$42.53	\$16.77	\$23.52	\$0.00	\$82.82
SPRINKLER FITTER <i>SPRINKLER FITTERS LOCAL 669</i>	04/01/2023	\$47.43	\$11.45	\$16.61	\$0.00	\$75.49

Apprentice - *SPRINKLER FITTER - Local 669*

Effective Date - 04/01/2023

Step	percent	Apprentice Base Wage	Health	Pension	Supplemental Unemployment	Total Rate
1	45	\$21.34	\$8.22	\$0.00	\$0.00	\$29.56
2	50	\$23.72	\$8.22	\$0.00	\$0.00	\$31.94
3	55	\$26.09	\$11.45	\$7.20	\$0.00	\$44.74
4	60	\$28.46	\$11.45	\$8.35	\$0.00	\$48.26
5	65	\$30.83	\$11.45	\$8.35	\$0.00	\$50.63
6	70	\$33.20	\$11.45	\$8.60	\$0.00	\$53.25
7	75	\$35.57	\$11.45	\$8.60	\$0.00	\$55.62
8	80	\$37.94	\$11.45	\$8.60	\$0.00	\$57.99
9	85	\$40.32	\$11.45	\$8.60	\$0.00	\$60.37
10	90	\$42.69	\$11.45	\$8.60	\$0.00	\$62.74

Notes:

Apprentice to Journeyworker Ratio:1:1

TELECOMMUNICATION TECHNICIAN <i>ELECTRICIANS LOCAL 7</i>	06/30/2024	\$50.01	\$13.00	\$14.86	\$0.00	\$77.87
	12/29/2024	\$51.06	\$13.25	\$15.06	\$0.00	\$79.37
	06/29/2025	\$52.16	\$13.50	\$15.21	\$0.00	\$80.87
	12/28/2025	\$53.26	\$13.75	\$15.36	\$0.00	\$82.37
	06/28/2026	\$54.41	\$14.00	\$15.46	\$0.00	\$83.87
	01/03/2027	\$55.56	\$14.25	\$15.56	\$0.00	\$85.37

Classification

Effective Date Base Wage Health Pension Supplemental Unemployment Total Rate

Apprentice - TELECOMMUNICATION TECHNICIAN - Local 7

Effective Date - 06/30/2024

Step	percent	Apprentice Base Wage	Health	Pension	Supplemental Unemployment	Total Rate
1	40	\$20.00	\$7.20	\$0.60	\$0.00	\$27.80
2	45	\$22.50	\$7.20	\$0.68	\$0.00	\$30.38
3	50	\$25.01	\$13.00	\$7.40	\$0.00	\$45.41
4	55	\$27.51	\$13.00	\$7.48	\$0.00	\$47.99
5	65	\$32.51	\$13.00	\$9.64	\$0.00	\$55.15
6	70	\$35.01	\$13.00	\$11.06	\$0.00	\$59.07

Effective Date - 12/29/2024

Step	percent	Apprentice Base Wage	Health	Pension	Supplemental Unemployment	Total Rate
1	40	\$20.42	\$7.35	\$0.61	\$0.00	\$28.38
2	45	\$22.98	\$7.35	\$0.69	\$0.00	\$31.02
3	50	\$25.53	\$13.25	\$7.47	\$0.00	\$46.25
4	55	\$28.08	\$13.25	\$7.54	\$0.00	\$48.87
5	65	\$33.19	\$13.25	\$9.74	\$0.00	\$56.18
6	70	\$35.74	\$13.25	\$11.19	\$0.00	\$60.18

Notes:

Steps are 800 hours

Apprentice to Journeyworker Ratio:1:1

TERRAZZO FINISHERS	08/01/2024	\$63.44	\$11.49	\$23.59	\$0.00	\$98.52
BRICKLAYERS LOCAL 3 (SPR/PITT) - MARBLE & TILE	02/01/2025	\$64.74	\$11.49	\$23.59	\$0.00	\$99.82
	08/01/2025	\$66.89	\$11.49	\$23.59	\$0.00	\$101.97
	02/10/2026	\$68.24	\$11.49	\$23.59	\$0.00	\$103.32
	08/01/2026	\$70.44	\$11.49	\$23.59	\$0.00	\$105.52
	02/01/2027	\$71.84	\$11.49	\$23.59	\$0.00	\$106.92

Classification	Effective Date	Base Wage	Health	Pension	Supplemental Unemployment	Total Rate
-----------------------	-----------------------	------------------	---------------	----------------	----------------------------------	-------------------

Apprentice - TERRAZZO MECH - Local 3 Marble/Tile (Spr/Pitt)

Effective Date - 08/01/2024

Step	percent	Apprentice Base Wage	Health	Pension	Supplemental Unemployment	Total Rate
1	50	\$32.26	\$11.49	\$23.56	\$0.00	\$67.31
2	60	\$38.71	\$11.49	\$23.56	\$0.00	\$73.76
3	70	\$45.16	\$11.49	\$23.56	\$0.00	\$80.21
4	80	\$51.62	\$11.49	\$23.56	\$0.00	\$86.67
5	90	\$58.07	\$11.49	\$23.56	\$0.00	\$93.12

Effective Date - 02/01/2025

Step	percent	Apprentice Base Wage	Health	Pension	Supplemental Unemployment	Total Rate
1	50	\$32.91	\$11.49	\$23.56	\$0.00	\$67.96
2	60	\$39.49	\$11.49	\$23.56	\$0.00	\$74.54
3	70	\$46.07	\$11.49	\$23.56	\$0.00	\$81.12
4	80	\$52.66	\$11.49	\$23.56	\$0.00	\$87.71
5	90	\$59.24	\$11.49	\$23.56	\$0.00	\$94.29

Notes:

Apprentice to Journeyworker Ratio:1:5

TEST BORING DRILLER <i>LABORERS - FOUNDATION AND MARINE</i>	12/01/2024	\$51.28	\$9.65	\$18.22	\$0.00	\$79.15
	06/01/2025	\$52.78	\$9.65	\$18.22	\$0.00	\$80.65
	12/01/2025	\$54.28	\$9.65	\$18.22	\$0.00	\$82.15
	06/01/2026	\$55.83	\$9.65	\$18.22	\$0.00	\$83.70
	12/01/2026	\$57.33	\$9.65	\$18.22	\$0.00	\$85.20

For apprentice rates see "Apprentice- LABORER"

TEST BORING DRILLER HELPER <i>LABORERS - FOUNDATION AND MARINE</i>	12/01/2024	\$47.07	\$9.65	\$18.22	\$0.00	\$74.94
	06/01/2025	\$48.57	\$9.65	\$18.22	\$0.00	\$76.44
	12/01/2025	\$50.07	\$9.65	\$18.22	\$0.00	\$77.94
	06/01/2026	\$51.62	\$9.65	\$18.22	\$0.00	\$79.49
	12/01/2026	\$53.12	\$9.65	\$18.22	\$0.00	\$80.99

For apprentice rates see "Apprentice- LABORER"

TEST BORING LABORER <i>LABORERS - FOUNDATION AND MARINE</i>	12/01/2024	\$46.95	\$9.65	\$18.22	\$0.00	\$74.82
	06/01/2025	\$48.45	\$9.65	\$18.22	\$0.00	\$76.32
	12/01/2025	\$49.95	\$9.65	\$18.22	\$0.00	\$77.82
	06/01/2026	\$51.50	\$9.65	\$18.22	\$0.00	\$79.37
	12/01/2026	\$53.00	\$9.65	\$18.22	\$0.00	\$80.87

For apprentice rates see "Apprentice- LABORER"

TRACTORS <i>OPERATING ENGINEERS LOCAL 98</i>	12/01/2023	\$38.42	\$13.78	\$15.15	\$0.00	\$67.35
--	------------	---------	---------	---------	--------	---------

For apprentice rates see "Apprentice- OPERATING ENGINEERS"

Classification	Effective Date	Base Wage	Health	Pension	Supplemental Unemployment	Total Rate
TRAILERS FOR EARTH MOVING EQUIPMENT <i>TEAMSTERS JOINT COUNCIL NO. 10 ZONE B</i>	12/01/2024	\$40.82	\$15.07	\$20.17	\$0.00	\$76.06
	01/01/2025	\$40.82	\$15.57	\$20.17	\$0.00	\$76.56
	06/01/2025	\$41.82	\$15.57	\$20.17	\$0.00	\$77.56
	12/01/2025	\$41.82	\$15.57	\$21.78	\$0.00	\$79.17
	01/01/2026	\$41.82	\$16.17	\$21.78	\$0.00	\$79.77
	06/01/2026	\$42.82	\$16.17	\$21.78	\$0.00	\$80.77
	12/01/2026	\$42.82	\$16.17	\$23.52	\$0.00	\$82.51
	01/01/2027	\$42.82	\$16.77	\$23.52	\$0.00	\$83.11
TUNNEL WORK - COMPRESSED AIR <i>LABORERS (COMPRESSED AIR)</i>	12/01/2024	\$59.18	\$9.65	\$19.00	\$0.00	\$87.83
	06/01/2025	\$60.68	\$9.65	\$19.00	\$0.00	\$89.33
	12/01/2025	\$62.18	\$9.65	\$19.00	\$0.00	\$90.83
	06/01/2026	\$63.73	\$9.65	\$19.00	\$0.00	\$92.38
	12/01/2026	\$65.23	\$9.65	\$19.00	\$0.00	\$93.88
For apprentice rates see "Apprentice- LABORER"						
TUNNEL WORK - COMPRESSED AIR (HAZ. WASTE) <i>LABORERS (COMPRESSED AIR)</i>	12/01/2024	\$61.18	\$9.65	\$19.00	\$0.00	\$89.83
	06/01/2025	\$62.68	\$9.65	\$19.00	\$0.00	\$91.33
	12/01/2025	\$64.18	\$9.65	\$19.00	\$0.00	\$92.83
	06/01/2026	\$65.73	\$9.65	\$19.00	\$0.00	\$94.38
	12/01/2026	\$67.23	\$9.65	\$19.00	\$0.00	\$95.88
For apprentice rates see "Apprentice- LABORER"						
TUNNEL WORK - FREE AIR <i>LABORERS (FREE AIR TUNNEL)</i>	12/01/2024	\$51.25	\$9.65	\$19.00	\$0.00	\$79.90
	06/01/2025	\$52.75	\$9.65	\$19.00	\$0.00	\$81.40
	12/01/2025	\$54.25	\$9.65	\$19.00	\$0.00	\$82.90
	06/01/2026	\$55.80	\$9.65	\$19.00	\$0.00	\$84.45
	12/01/2026	\$57.30	\$9.65	\$19.00	\$0.00	\$85.95
For apprentice rates see "Apprentice- LABORER"						
TUNNEL WORK - FREE AIR (HAZ. WASTE) <i>LABORERS (FREE AIR TUNNEL)</i>	12/01/2024	\$53.25	\$9.65	\$19.00	\$0.00	\$81.90
	06/01/2025	\$54.75	\$9.65	\$19.00	\$0.00	\$83.40
	12/01/2025	\$56.25	\$9.65	\$19.00	\$0.00	\$84.90
	06/01/2026	\$57.80	\$9.65	\$19.00	\$0.00	\$86.45
	12/01/2026	\$59.30	\$9.65	\$19.00	\$0.00	\$87.95
For apprentice rates see "Apprentice- LABORER"						
VAC-HAUL <i>TEAMSTERS JOINT COUNCIL NO. 10 ZONE B</i>	12/01/2024	\$40.24	\$15.07	\$20.17	\$0.00	\$75.48
	01/01/2025	\$40.24	\$15.57	\$20.17	\$0.00	\$75.98
	06/01/2025	\$41.24	\$15.57	\$20.17	\$0.00	\$76.98
	12/01/2025	\$41.24	\$15.57	\$21.78	\$0.00	\$78.59
	01/01/2026	\$41.24	\$16.17	\$21.78	\$0.00	\$79.19
	06/01/2026	\$42.24	\$16.17	\$21.78	\$0.00	\$80.19
	12/01/2026	\$42.24	\$16.17	\$23.52	\$0.00	\$81.93
	01/01/2027	\$42.24	\$16.77	\$23.52	\$0.00	\$82.53

Classification	Effective Date	Base Wage	Health	Pension	Supplemental Unemployment	Total Rate
WAGON DRILL OPERATOR <i>LABORERS - ZONE 3 (BUILDING & SITE)</i>	12/02/2024	\$36.00	\$9.65	\$17.07	\$0.00	\$62.72
	06/02/2025	\$37.25	\$9.65	\$17.07	\$0.00	\$63.97
	12/01/2025	\$38.50	\$9.65	\$17.07	\$0.00	\$65.22
	06/01/2026	\$39.80	\$9.65	\$17.07	\$0.00	\$66.52
	12/07/2026	\$41.10	\$9.65	\$17.07	\$0.00	\$67.82
	06/07/2027	\$42.50	\$9.65	\$17.07	\$0.00	\$69.22
	12/06/2027	\$43.90	\$9.65	\$17.07	\$0.00	\$70.62
	06/05/2028	\$45.40	\$9.65	\$17.07	\$0.00	\$72.12
	12/04/2028	\$46.90	\$9.65	\$17.07	\$0.00	\$73.62
For apprentice rates see "Apprentice- LABORER"						
WAGON DRILL OPERATOR (HEAVY & HIGHWAY) <i>LABORERS - ZONE 3 (HEAVY & HIGHWAY)</i>	12/01/2024	\$36.00	\$9.65	\$15.06	\$0.00	\$60.71
	06/01/2025	\$37.25	\$9.65	\$15.06	\$0.00	\$61.96
	12/01/2025	\$38.49	\$9.65	\$15.06	\$0.00	\$63.20
	06/01/2026	\$39.79	\$9.65	\$15.06	\$0.00	\$64.50
	12/01/2026	\$41.08	\$9.65	\$15.06	\$0.00	\$65.79
For apprentice rates see "Apprentice- LABORER (Heavy and Highway)"						
WATER METER INSTALLER <i>PLUMBERS & PIPEFITTERS LOCAL 104</i>	03/17/2024	\$49.21	\$9.55	\$17.10	\$0.00	\$75.86
For apprentice rates see "Apprentice- PLUMBER/PIPEFITTER" or "PLUMBER/GASFITTER"						
Marine Drilling						
BLASTER <i>MARINE DRILLING</i>	01/01/2018	\$41.82	\$7.63	\$3.60	\$0.00	\$53.05
BOAT CAPTAIN <i>MARINE DRILLING</i>	01/01/2018	\$33.87	\$7.63	\$3.30	\$0.00	\$44.80
BOAT CAPTAIN / Over 1,000 hp <i>MARINE DRILLING</i>	01/01/2018	\$38.06	\$7.63	\$3.60	\$0.00	\$49.29
CORE DRILLER <i>MARINE DRILLING</i>	01/01/2018	\$31.43	\$7.63	\$2.90	\$0.00	\$41.96
CORE DRILLER HELPER <i>MARINE DRILLING</i>	01/01/2018	\$28.47	\$7.63	\$3.00	\$0.00	\$39.10
DRILLER <i>MARINE DRILLING</i>	01/01/2018	\$39.70	\$7.63	\$3.60	\$0.00	\$50.93
ENGINEER <i>MARINE DRILLING</i>	01/01/2018	\$39.69	\$7.63	\$3.50	\$0.00	\$50.82
HELPER <i>MARINE DRILLING</i>	01/01/2018	\$34.24	\$7.63	\$3.00	\$0.00	\$44.87
MACHINIST <i>MARINE DRILLING</i>	01/01/2018	\$38.88	\$7.63	\$3.30	\$0.00	\$49.81
OILER - MARINE DRILLING <i>MARINE DRILLING</i>	01/01/2018	\$34.24	\$7.63	\$3.00	\$0.00	\$44.87
TUG DECKHAND <i>MARINE DRILLING</i>	01/01/2018	\$27.61	\$7.63	\$3.00	\$0.00	\$38.24
WELDER <i>MARINE DRILLING</i>	01/01/2018	\$38.88	\$7.63	\$3.30	\$0.00	\$49.81
Op Eng Marine (Dredging Work)						
BOAT OPERATOR <i>OPERATING ENGINEERS - MARINE DIVISION</i>	10/01/2017	\$29.26	\$7.63	\$3.30	\$0.00	\$40.19
CERTIFIED WELDER <i>OPERATING ENGINEERS - MARINE DIVISION</i>	10/01/2017	\$31.09	\$7.63	\$3.60	\$0.00	\$42.32

Classification	Effective Date	Base Wage	Health	Pension	Supplemental Unemployment	Total Rate
CHIEF WELDER/ CHIEF MATE <i>OPERATING ENGINEERS - MARINE DIVISION</i>	10/01/2017	\$33.02	\$7.63	\$3.60	\$0.00	\$44.25
DERRICK / SPIDER / SPILLBARGE OPERATOR <i>OPERATING ENGINEERS - MARINE DIVISION</i>	10/01/2017	\$33.02	\$7.63	\$3.60	\$0.00	\$44.25
DRAG BARGE OPERATOR / WELDER / MATE <i>OPERATING ENGINEERS - MARINE DIVISION</i>	10/01/2017	\$30.24	\$7.63	\$3.30	\$0.00	\$41.17
ENGINEER / ELECTRICIAN <i>OPERATING ENGINEERS - MARINE DIVISION</i>	10/01/2017	\$33.02	\$7.63	\$3.60	\$0.00	\$44.25
LICENSED BOAT OPERATOR <i>OPERATING ENGINEERS - MARINE DIVISION</i>	10/01/2017	\$33.02	\$7.63	\$3.60	\$0.00	\$44.25
LICENSED TUG OPERATOR OVER 1000HP <i>OPERATING ENGINEERS - MARINE DIVISION</i>	10/01/2017	\$38.18	\$7.63	\$3.60	\$0.00	\$49.41
MAINTENANCE ENGINEER <i>OPERATING ENGINEERS - MARINE DIVISION</i>	10/01/2017	\$33.03	\$7.63	\$3.60	\$0.00	\$44.26
OILER - MARINE DIVISION <i>OPERATING ENGINEERS - MARINE DIVISION</i>	10/01/2017	\$24.30	\$7.63	\$3.00	\$0.00	\$34.93
OPERATOR / LEVERMAN <i>OPERATING ENGINEERS - MARINE DIVISION</i>	10/01/2017	\$38.18	\$7.63	\$3.60	\$0.00	\$49.41
RODMAN / SCOWMAN <i>OPERATING ENGINEERS - MARINE DIVISION</i>	10/01/2017	\$24.30	\$7.63	\$3.00	\$0.00	\$34.93
SHOREMAN / DECKHAND <i>OPERATING ENGINEERS - MARINE DIVISION</i>	10/01/2017	\$24.30	\$7.63	\$3.00	\$0.00	\$34.93

Additional Apprentices Information:

All apprentices must be registered with the Division of Apprenticeship Training (DAS) in accordance with M.G.L. c. 23, §§ 11E-11L. Minimum wage rates for apprentices employed on public works projects are listed above as a percentage of the hourly prevailing wage rate established by the Commissioner under the provisions of M.G.L. c. 149, §§ 26-27D. Apprentice ratios are established by DAS pursuant to M.G.L. c. 23, §§ 11E-11L. Ratios are expressed as the allowable number of apprentices to journeymen or fraction thereof, unless otherwise specified. The ratios listed herein have been taken from relevant private collective bargaining agreements (CBAs) and are provided for illustrative purposes only. They have not been independently verified as being accurate or continuing to be accurate. Parties having questions regarding what ratio to use should contact DAS.

THIS PAGE IS INTENTIONALLY LEFT BLANK



MAURA HEALEY
Governor

KIM DRISCOLL
Lt. Governor

THE COMMONWEALTH OF MASSACHUSETTS
EXECUTIVE OFFICE OF LABOR AND WORKFORCE DEVELOPMENT
DEPARTMENT OF LABOR STANDARDS

Prevailing Wage Rates

As determined by the Director under the provisions of the
Massachusetts General Laws, Chapter 149, Sections 26 to 27H

LAUREN JONES
Secretary

MICHAEL FLANAGAN
Director

Awarding Authority: MassDOT Highway
Contract Number: 129070 **City/Town:** CHICOPEE
Description of Work: WEST SPRINGFIELD - CHICOPEE - Federal Aid Project No. NHP(IM)/HIP(BR)-0912(310)X Pavement and Bridge Preservation on I-91
Job Location: Along I-91

Information about Prevailing Wage Schedules for Awarding Authorities and Contractors

- The wage rates will remain in effect for the duration of the project, except in the case of multi-year public construction projects. For construction projects lasting longer than one year, awarding authorities must request an updated wage schedule no later than two weeks before the anniversary of the date the contract was executed by the awarding authority and the general contractor. For multi-year CM AT RISK projects, the awarding authority must request an annual update no later than two weeks before the anniversary date, determined as the earlier of: (a) the execution date of the GMP Amendment, or (b) the execution date of the first amendment to permit procurement of construction services. The updated wage schedule must be provided to all contractors, including general and sub-contractors, working on the construction project.
- This annual update requirement is generally not applicable to 27F "rental of equipment" contracts. For such contracts, the prevailing wage rates issued by DLS shall remain in effect for the duration of the contract term. However, if the prevailing wage rate sheet issued does not contain wage rates for each year covered by the contract term, the Awarding Authority must request updated rate sheets from DLS and provide them to the contractor to ensure the correct rates are being paid throughout the duration of the contract. Additionally, if an Awarding Authority exercises an option to renew or extend the contract term, they must request updated rate sheets from DLS and provide them to the contractor.
- This wage schedule applies only to the specific project referenced at the top of this page and uniquely identified by the "Wage Request Number" on all pages of this schedule.
- An Awarding Authority must request an updated wage schedule if it has not opened bids or selected a contractor within 90 days of the date of issuance of the wage schedule. For CM AT RISK projects (bid pursuant to G.L. c.149A), the earlier of: (a) the execution date of the GMP Amendment, or (b) the bid for the first construction scope of work must be within 90-days of the wage schedule issuance date.
- The wage schedule shall be incorporated in any advertisement or call for bids for the project as required by M.G.L. c. 149, § 27. The wage schedule shall be made a part of the contract awarded for the project. The wage schedule must be posted in a conspicuous place at the work site for the life of the project in accordance with M.G.L. c. 149 § 27. The wages listed on the wage schedule must be paid to employees performing construction work on the project whether they are employed by the prime contractor, a filed sub-bidder, or a sub-contractor.
- Apprentices working on the project are required to be registered with the Massachusetts Division of Apprentice Standards (DAS). Apprentices must keep their apprentice identification card on their persons during all work hours on the project. An apprentice registered with DAS may be paid the lower apprentice wage rate at the applicable step as provided on the prevailing wage schedule. **Any apprentice not registered with DAS regardless of whether they are registered with another federal, state, local, or private agency must be paid the journeyworker's rate.**
- Every contractor or subcontractor working on the construction project must submit weekly payroll reports and a Statement of Compliance directly to the awarding authority by mail or email and keep them on file for three years. Each weekly payroll report must contain: the employee's name, address, occupational classification, hours worked, and wages paid. Do not submit weekly payroll reports to DLS. For a sample payroll reporting form go to <http://www.mass.gov/dols/pw>.
- Contractors with questions about the wage rates or classifications included on the wage schedule have an affirmative obligation to inquire with DLS at (617) 626-6953.
- Contractors must obtain the wage schedules from awarding authorities. Failure of a contractor or subcontractor to pay the prevailing wage rates listed on the wage schedule to all employees who perform construction work on the project is a violation of the law and subjects the contractor or subcontractor to civil and criminal penalties.
- Employees not receiving the prevailing wage rate set forth on the wage schedule may file a complaint with the Fair Labor Division of the office of the Attorney General at (617) 727-3465.

Issue Date: 12/27/2024

Wage Request Number: 20241227-016-1

Classification	Effective Date	Base Wage	Health	Pension	Supplemental Unemployment	Total Rate
Construction						
(2 AXLE) DRIVER - EQUIPMENT <i>TEAMSTERS JOINT COUNCIL NO. 10 ZONE B</i>	12/01/2024	\$39.95	\$15.07	\$20.17	\$0.00	\$75.19
	01/01/2025	\$39.95	\$15.57	\$20.17	\$0.00	\$75.69
	06/01/2025	\$40.95	\$15.57	\$20.17	\$0.00	\$76.69
	12/01/2025	\$40.95	\$15.57	\$21.78	\$0.00	\$78.30
	01/01/2026	\$40.95	\$16.17	\$21.78	\$0.00	\$78.90
	06/01/2026	\$41.95	\$16.17	\$21.78	\$0.00	\$79.90
	12/01/2026	\$41.95	\$16.17	\$23.52	\$0.00	\$81.64
	01/01/2027	\$41.95	\$16.77	\$23.52	\$0.00	\$82.24
(3 AXLE) DRIVER - EQUIPMENT <i>TEAMSTERS JOINT COUNCIL NO. 10 ZONE B</i>	12/01/2024	\$40.02	\$15.07	\$20.17	\$0.00	\$75.26
	01/01/2025	\$40.02	\$15.57	\$20.17	\$0.00	\$75.76
	06/01/2025	\$41.02	\$15.57	\$20.17	\$0.00	\$76.76
	12/01/2025	\$41.02	\$15.57	\$21.78	\$0.00	\$78.37
	01/01/2026	\$41.02	\$16.17	\$21.78	\$0.00	\$78.97
	06/01/2026	\$42.02	\$16.17	\$21.78	\$0.00	\$79.97
	12/01/2026	\$42.02	\$16.17	\$23.52	\$0.00	\$81.71
	01/01/2027	\$42.02	\$16.77	\$23.52	\$0.00	\$82.31
(4 & 5 AXLE) DRIVER - EQUIPMENT <i>TEAMSTERS JOINT COUNCIL NO. 10 ZONE B</i>	12/01/2024	\$40.14	\$15.07	\$20.17	\$0.00	\$75.38
	01/01/2025	\$40.14	\$15.57	\$20.17	\$0.00	\$75.88
	06/01/2025	\$41.14	\$15.57	\$20.17	\$0.00	\$76.88
	12/01/2025	\$41.14	\$15.57	\$21.78	\$0.00	\$78.49
	01/01/2026	\$41.14	\$16.17	\$21.78	\$0.00	\$79.09
	06/01/2026	\$42.14	\$16.17	\$21.78	\$0.00	\$80.09
	12/01/2026	\$42.14	\$16.17	\$23.52	\$0.00	\$81.83
	01/01/2027	\$42.14	\$16.77	\$23.52	\$0.00	\$82.43
ADS/SUBMERSIBLE PILOT <i>PILE DRIVER LOCAL 56 (ZONE 3)</i>	08/01/2024	\$117.16	\$10.08	\$24.29	\$0.00	\$151.53
For apprentice rates see "Apprentice- PILE DRIVER"						
AIR TRACK OPERATOR <i>LABORERS - ZONE 3 (BUILDING & SITE)</i>	12/02/2024	\$36.50	\$9.65	\$17.07	\$0.00	\$63.22
	06/02/2025	\$37.75	\$9.65	\$17.07	\$0.00	\$64.47
	12/01/2025	\$39.00	\$9.65	\$17.07	\$0.00	\$65.72
	06/01/2026	\$40.30	\$9.65	\$17.07	\$0.00	\$67.02
	12/07/2026	\$41.60	\$9.65	\$17.07	\$0.00	\$68.32
	06/07/2027	\$43.00	\$9.65	\$17.07	\$0.00	\$69.72
	12/06/2027	\$44.40	\$9.65	\$17.07	\$0.00	\$71.12
	06/05/2028	\$45.90	\$9.65	\$17.07	\$0.00	\$72.62
For apprentice rates see "Apprentice- LABORER"						
AIR TRACK OPERATOR (HEAVY & HIGHWAY) <i>LABORERS - ZONE 3 (HEAVY & HIGHWAY)</i>	12/01/2024	\$36.50	\$9.65	\$15.06	\$0.00	\$61.21
	06/01/2025	\$37.75	\$9.65	\$15.06	\$0.00	\$62.46
	12/01/2025	\$38.99	\$9.65	\$15.06	\$0.00	\$63.70
	06/01/2026	\$40.29	\$9.65	\$15.06	\$0.00	\$65.00
	12/01/2026	\$41.58	\$9.65	\$15.06	\$0.00	\$66.29
For apprentice rates see "Apprentice- LABORER (Heavy and Highway)"						

Classification	Effective Date	Base Wage	Health	Pension	Supplemental Unemployment	Total Rate
ASBESTOS WORKER (PIPES & TANKS) <i>HEAT & FROST INSULATORS LOCAL 6 (SPRINGFIELD)</i>	12/01/2024	\$38.52	\$14.50	\$10.55	\$0.00	\$63.57
	06/01/2025	\$39.42	\$14.50	\$10.55	\$0.00	\$64.47
	12/01/2025	\$40.32	\$14.50	\$10.55	\$0.00	\$65.37
ASPHALT RAKER <i>LABORERS - ZONE 3 (BUILDING & SITE)</i>	12/02/2024	\$36.00	\$9.65	\$17.07	\$0.00	\$62.72
	06/02/2025	\$37.25	\$9.65	\$17.07	\$0.00	\$63.97
	12/01/2025	\$38.50	\$9.65	\$17.07	\$0.00	\$65.22
	06/01/2026	\$39.80	\$9.65	\$17.07	\$0.00	\$66.52
	12/07/2026	\$41.10	\$9.65	\$17.07	\$0.00	\$67.82
	06/07/2027	\$42.50	\$9.65	\$17.07	\$0.00	\$69.22
	12/06/2027	\$43.90	\$9.65	\$17.07	\$0.00	\$70.62
	06/05/2028	\$45.40	\$9.65	\$17.07	\$0.00	\$72.12
12/04/2028	\$46.90	\$9.65	\$17.07	\$0.00	\$73.62	
For apprentice rates see "Apprentice- LABORER"						
ASPHALT RAKER (HEAVY & HIGHWAY) <i>LABORERS - ZONE 3 (HEAVY & HIGHWAY)</i>	12/01/2024	\$36.00	\$9.65	\$15.06	\$0.00	\$60.71
	06/01/2025	\$37.25	\$9.65	\$15.06	\$0.00	\$61.96
	12/01/2025	\$38.49	\$9.65	\$15.06	\$0.00	\$63.20
	06/01/2026	\$39.79	\$9.65	\$15.06	\$0.00	\$64.50
	12/01/2026	\$41.08	\$9.65	\$15.06	\$0.00	\$65.79
For apprentice rates see "Apprentice- LABORER (Heavy and Highway)"						
AUTOMATIC GRADER-EXCAVATOR (RECLAIMER) <i>OPERATING ENGINEERS LOCAL 98</i>	12/01/2023	\$39.56	\$13.78	\$15.15	\$0.00	\$68.49
For apprentice rates see "Apprentice- OPERATING ENGINEERS"						
BACKHOE/FRONT-END LOADER OPERATOR <i>OPERATING ENGINEERS LOCAL 98</i>	12/01/2023	\$39.56	\$13.78	\$15.15	\$0.00	\$68.49
For apprentice rates see "Apprentice- OPERATING ENGINEERS"						
BARCO-TYPE JUMPING TAMPER <i>LABORERS - ZONE 3 (BUILDING & SITE)</i>	12/02/2024	\$36.00	\$9.65	\$17.07	\$0.00	\$62.72
	06/02/2025	\$37.25	\$9.65	\$17.07	\$0.00	\$63.97
	12/01/2025	\$38.50	\$9.65	\$17.07	\$0.00	\$65.22
	06/01/2026	\$39.80	\$9.65	\$17.07	\$0.00	\$66.52
	12/07/2026	\$41.10	\$9.65	\$17.07	\$0.00	\$67.82
	06/07/2027	\$42.50	\$9.65	\$17.07	\$0.00	\$69.22
	12/06/2027	\$43.90	\$9.65	\$17.07	\$0.00	\$70.62
	06/05/2028	\$45.40	\$9.65	\$17.07	\$0.00	\$72.12
12/04/2028	\$46.90	\$9.65	\$17.07	\$0.00	\$73.62	
For apprentice rates see "Apprentice- LABORER"						
BATCH/CEMENT PLANT - ON SITE <i>OPERATING ENGINEERS LOCAL 98</i>	12/01/2023	\$39.03	\$13.78	\$15.15	\$0.00	\$67.96
For apprentice rates see "Apprentice- OPERATING ENGINEERS"						
BLOCK PAVER, RAMMER / CURB SETTER <i>LABORERS - ZONE 3 (BUILDING & SITE)</i>	12/02/2024	\$36.50	\$9.65	\$17.07	\$0.00	\$63.22
	06/02/2025	\$37.75	\$9.65	\$17.07	\$0.00	\$64.47
	12/01/2025	\$39.00	\$9.65	\$17.07	\$0.00	\$65.72
	06/01/2026	\$40.30	\$9.65	\$17.07	\$0.00	\$67.02
	12/07/2026	\$41.60	\$9.65	\$17.07	\$0.00	\$68.32
	06/07/2027	\$43.00	\$9.65	\$17.07	\$0.00	\$69.72
	12/06/2027	\$44.40	\$9.65	\$17.07	\$0.00	\$71.12
	06/05/2028	\$45.90	\$9.65	\$17.07	\$0.00	\$72.62
12/04/2028	\$47.40	\$9.65	\$17.07	\$0.00	\$74.12	
For apprentice rates see "Apprentice- LABORER"						

Classification	Effective Date	Base Wage	Health	Pension	Supplemental Unemployment	Total Rate
BLOCK PAVER, RAMMER / CURB SETTER (HEAVY & HIGHWAY) <i>LABORERS - ZONE 3 (HEAVY & HIGHWAY)</i>	12/01/2024	\$36.50	\$9.65	\$15.06	\$0.00	\$61.21
	06/01/2025	\$37.75	\$9.65	\$15.06	\$0.00	\$62.46
	12/01/2025	\$38.99	\$9.65	\$15.06	\$0.00	\$63.70
	06/01/2026	\$40.29	\$9.65	\$15.06	\$0.00	\$65.00
	12/01/2026	\$41.58	\$9.65	\$15.06	\$0.00	\$66.29
For apprentice rates see "Apprentice- LABORER (Heavy and Highway)						
BOILER MAKER <i>BOILERMAKERS LOCAL 29</i>	01/01/2024	\$48.12	\$7.07	\$20.60	\$0.00	\$75.79

Apprentice - BOILERMAKER - Local 29

Effective Date - 01/01/2024

Step	percent	Apprentice Base Wage	Health	Pension	Supplemental Unemployment	Total Rate
1	65	\$31.28	\$7.07	\$13.22	\$0.00	\$51.57
2	65	\$31.28	\$7.07	\$13.22	\$0.00	\$51.57
3	70	\$33.68	\$7.07	\$14.23	\$0.00	\$54.98
4	75	\$36.09	\$7.07	\$15.24	\$0.00	\$58.40
5	80	\$38.50	\$7.07	\$16.25	\$0.00	\$61.82
6	85	\$40.90	\$7.07	\$17.28	\$0.00	\$65.25
7	90	\$43.31	\$7.07	\$18.28	\$0.00	\$68.66
8	95	\$45.71	\$7.07	\$19.32	\$0.00	\$72.10

Notes:

Apprentice to Journeyworker Ratio:1:4

BRICK/STONE/ARTIFICIAL MASONRY (INCL. MASONRY WATERPROOFING) <i>BRICKLAYERS LOCAL 3 (SPRINGFIELD/PITTSFIELD)</i>	08/01/2024	\$52.06	\$11.49	\$21.46	\$0.00	\$85.01
	02/01/2025	\$53.36	\$11.49	\$21.46	\$0.00	\$86.31
	08/01/2025	\$55.51	\$11.49	\$21.46	\$0.00	\$88.46
	02/01/2026	\$56.86	\$11.49	\$21.46	\$0.00	\$89.81
	08/01/2026	\$59.06	\$11.49	\$21.46	\$0.00	\$92.01
	02/01/2027	\$60.46	\$11.49	\$21.46	\$0.00	\$93.41

Classification	Effective Date	Base Wage	Health	Pension	Supplemental Unemployment	Total Rate
-----------------------	-----------------------	------------------	---------------	----------------	----------------------------------	-------------------

Apprentice - BRICK/PLASTER/CEMENT MASON - Local 3 Springfield/Pittsfield

Effective Date - 08/01/2024

Step	percent	Apprentice Base Wage	Health	Pension	Supplemental Unemployment	Total Rate
1	50	\$26.03	\$11.49	\$21.46	\$0.00	\$58.98
2	60	\$31.24	\$11.49	\$21.46	\$0.00	\$64.19
3	70	\$36.44	\$11.49	\$21.46	\$0.00	\$69.39
4	80	\$41.65	\$11.49	\$21.46	\$0.00	\$74.60
5	90	\$46.85	\$11.49	\$21.46	\$0.00	\$79.80

Effective Date - 02/01/2025

Step	percent	Apprentice Base Wage	Health	Pension	Supplemental Unemployment	Total Rate
1	50	\$26.68	\$11.49	\$21.46	\$0.00	\$59.63
2	60	\$32.02	\$11.49	\$21.46	\$0.00	\$64.97
3	70	\$37.35	\$11.49	\$21.46	\$0.00	\$70.30
4	80	\$42.69	\$11.49	\$21.46	\$0.00	\$75.64
5	90	\$48.02	\$11.49	\$21.46	\$0.00	\$80.97

Notes:

Apprentice to Journeyworker Ratio:1:5

BULLDOZER/POWER SHOVEL/TREE SHREDDER /CLAM SHELL OPERATING	12/01/2023	\$39.56	\$13.78	\$15.15	\$0.00	\$68.49
---	------------	---------	---------	---------	--------	---------

ENGINEERS LOCAL 98

For apprentice rates see "Apprentice- OPERATING ENGINEERS"

CAISSON & UNDERPINNING BOTTOM MAN LABORERS - FOUNDATION AND MARINE	12/01/2024	\$48.10	\$9.65	\$18.22	\$0.00	\$75.97
	06/01/2025	\$49.60	\$9.65	\$18.22	\$0.00	\$77.47
	12/01/2025	\$51.10	\$9.65	\$18.22	\$0.00	\$78.97
	06/01/2026	\$52.65	\$9.65	\$18.22	\$0.00	\$80.52
	12/01/2026	\$54.15	\$9.65	\$18.22	\$0.00	\$82.02

For apprentice rates see "Apprentice- LABORER"

CAISSON & UNDERPINNING LABORER LABORERS - FOUNDATION AND MARINE	12/01/2024	\$46.95	\$9.65	\$18.22	\$0.00	\$74.82
	06/01/2025	\$48.45	\$9.65	\$18.22	\$0.00	\$76.32
	12/01/2025	\$49.95	\$9.65	\$18.22	\$0.00	\$77.82
	06/01/2026	\$51.50	\$9.65	\$18.22	\$0.00	\$79.37
	12/01/2026	\$53.00	\$9.65	\$18.22	\$0.00	\$80.87

For apprentice rates see "Apprentice- LABORER"

CAISSON & UNDERPINNING TOP MAN LABORERS - FOUNDATION AND MARINE	12/01/2024	\$47.28	\$9.65	\$18.22	\$0.00	\$75.15
	06/01/2025	\$48.78	\$9.65	\$18.22	\$0.00	\$76.65
	12/01/2025	\$50.28	\$9.65	\$18.22	\$0.00	\$78.15
	06/01/2026	\$51.83	\$9.65	\$18.22	\$0.00	\$79.70
	12/01/2026	\$53.33	\$9.65	\$18.22	\$0.00	\$81.20

For apprentice rates see "Apprentice- LABORER"

Classification	Effective Date	Base Wage	Health	Pension	Supplemental Unemployment	Total Rate
CARBIDE CORE DRILL OPERATOR <i>LABORERS - ZONE 3 (BUILDING & SITE)</i>	12/02/2024	\$36.00	\$9.65	\$17.07	\$0.00	\$62.72
	06/02/2025	\$37.25	\$9.65	\$17.07	\$0.00	\$63.97
	12/01/2025	\$38.50	\$9.65	\$17.07	\$0.00	\$65.22
	06/01/2026	\$39.80	\$9.65	\$17.07	\$0.00	\$66.52
	12/07/2026	\$41.10	\$9.65	\$17.07	\$0.00	\$67.82
	06/07/2027	\$42.50	\$9.65	\$17.07	\$0.00	\$69.22
	12/06/2027	\$43.90	\$9.65	\$17.07	\$0.00	\$70.62
	06/05/2028	\$45.40	\$9.65	\$17.07	\$0.00	\$72.12
	12/04/2028	\$46.90	\$9.65	\$17.07	\$0.00	\$73.62

For apprentice rates see "Apprentice- LABORER"

CARPENTER <i>CARPENTERS LOCAL 336 - HAMPDEN HAMPSHIRE FRANKLIN</i>	09/01/2024	\$42.36	\$7.91	\$18.15	\$0.00	\$68.42
	03/01/2025	\$43.26	\$7.91	\$18.15	\$0.00	\$69.32
	09/01/2025	\$44.21	\$7.91	\$18.15	\$0.00	\$70.27
	03/01/2026	\$45.11	\$7.91	\$18.15	\$0.00	\$71.17
	09/01/2026	\$46.06	\$7.91	\$18.15	\$0.00	\$72.12
	03/01/2027	\$46.96	\$7.91	\$18.15	\$0.00	\$73.02

Apprentice - CARPENTER - Local 336 Hampden Hampshire Franklin

Effective Date - 09/01/2024

Step	percent	Apprentice Base Wage	Health	Pension	Supplemental Unemployment	Total Rate
1	45	\$19.06	\$7.91	\$1.40	\$0.00	\$28.37
2	45	\$19.06	\$7.91	\$1.40	\$0.00	\$28.37
3	55	\$23.30	\$7.91	\$2.76	\$0.00	\$33.97
4	55	\$23.30	\$7.91	\$2.76	\$0.00	\$33.97
5	70	\$29.65	\$7.91	\$15.39	\$0.00	\$52.95
6	70	\$29.65	\$7.91	\$15.39	\$0.00	\$52.95
7	80	\$33.89	\$7.91	\$16.77	\$0.00	\$58.57
8	80	\$33.89	\$7.91	\$16.77	\$0.00	\$58.57

Effective Date - 03/01/2025

Step	percent	Apprentice Base Wage	Health	Pension	Supplemental Unemployment	Total Rate
1	45	\$19.47	\$7.91	\$1.40	\$0.00	\$28.78
2	45	\$19.47	\$7.91	\$1.40	\$0.00	\$28.78
3	55	\$23.79	\$7.91	\$2.76	\$0.00	\$34.46
4	55	\$23.79	\$7.91	\$2.76	\$0.00	\$34.46
5	70	\$30.28	\$7.91	\$15.39	\$0.00	\$53.58
6	70	\$30.28	\$7.91	\$15.39	\$0.00	\$53.58
7	80	\$34.61	\$7.91	\$16.77	\$0.00	\$59.29
8	80	\$34.61	\$7.91	\$16.77	\$0.00	\$59.29

Notes:

Apprentice to Journeyworker Ratio:1:5

Classification	Effective Date	Base Wage	Health	Pension	Supplemental Unemployment	Total Rate
CARPENTER WOOD FRAME	10/01/2024	\$26.65	\$7.02	\$4.80	\$0.00	\$38.47
<i>CARPENTERS-ZONE 3 (Wood Frame)</i>	10/01/2025	\$27.75	\$7.02	\$4.80	\$0.00	\$39.57
	10/01/2026	\$28.85	\$7.02	\$4.80	\$0.00	\$40.67

All Aspects of New Wood Frame Work

Apprentice - CARPENTER (Wood Frame) - Zone 3

Effective Date - 10/01/2024

Step	percent	Apprentice Base Wage	Health	Pension	Supplemental Unemployment	Total Rate
1	60	\$15.99	\$7.02	\$0.00	\$0.00	\$23.01
2	60	\$15.99	\$7.02	\$0.00	\$0.00	\$23.01
3	65	\$17.32	\$7.02	\$1.00	\$0.00	\$25.34
4	70	\$18.66	\$7.02	\$1.00	\$0.00	\$26.68
5	75	\$19.99	\$7.02	\$4.80	\$0.00	\$31.81
6	80	\$21.32	\$7.02	\$4.80	\$0.00	\$33.14
7	85	\$22.65	\$7.02	\$4.80	\$0.00	\$34.47
8	90	\$23.99	\$7.02	\$4.80	\$0.00	\$35.81

Effective Date - 10/01/2025

Step	percent	Apprentice Base Wage	Health	Pension	Supplemental Unemployment	Total Rate
1	60	\$16.65	\$7.02	\$0.00	\$0.00	\$23.67
2	60	\$16.65	\$7.02	\$0.00	\$0.00	\$23.67
3	65	\$18.04	\$7.02	\$1.00	\$0.00	\$26.06
4	70	\$19.43	\$7.02	\$1.00	\$0.00	\$27.45
5	75	\$20.81	\$7.02	\$4.80	\$0.00	\$32.63
6	80	\$22.20	\$7.02	\$4.80	\$0.00	\$34.02
7	85	\$23.59	\$7.02	\$4.80	\$0.00	\$35.41
8	90	\$24.98	\$7.02	\$4.80	\$0.00	\$36.80

Notes:

Apprentice to Journeyworker Ratio:1:5

CEMENT MASONRY/PLASTERING	01/01/2024	\$44.68	\$12.90	\$18.66	\$1.25	\$77.49
<i>BRICKLAYERS LOCAL 3 (SPRINGFIELD/PITTSFIELD)</i>						

Classification	Effective Date	Base Wage	Health	Pension	Supplemental Unemployment	Total Rate
-----------------------	-----------------------	------------------	---------------	----------------	----------------------------------	-------------------

Apprentice - CEMENT MASONRY/PLASTERING - Springfield/Pittsfield

Effective Date - 01/01/2024

Step	percent	Apprentice Base Wage	Health	Pension	Supplemental Unemployment	Total Rate
1	50	\$22.34	\$12.90	\$15.86	\$0.00	\$51.10
2	60	\$26.81	\$12.90	\$18.66	\$1.25	\$59.62
3	65	\$29.04	\$12.90	\$18.66	\$1.25	\$61.85
4	70	\$31.28	\$12.90	\$18.66	\$1.25	\$64.09
5	75	\$33.51	\$12.90	\$18.66	\$1.25	\$66.32
6	80	\$35.74	\$12.90	\$18.66	\$1.25	\$68.55
7	90	\$40.21	\$12.90	\$18.66	\$1.25	\$73.02

Notes:

Steps 3,4 are 500 hrs. All other steps are 1,000 hrs.

Apprentice to Journeyworker Ratio:1:3

CHAIN SAW OPERATOR <i>LABORERS - ZONE 3 (BUILDING & SITE)</i>	12/02/2024	\$36.00	\$9.65	\$17.07	\$0.00	\$62.72
	06/02/2025	\$37.25	\$9.65	\$17.07	\$0.00	\$63.97
	12/01/2025	\$38.50	\$9.65	\$17.07	\$0.00	\$65.22
	06/01/2026	\$39.80	\$9.65	\$17.07	\$0.00	\$66.52
	12/07/2026	\$41.10	\$9.65	\$17.07	\$0.00	\$67.82
	06/07/2027	\$42.50	\$9.65	\$17.07	\$0.00	\$69.22
	12/06/2027	\$43.90	\$9.65	\$17.07	\$0.00	\$70.62
	06/05/2028	\$45.40	\$9.65	\$17.07	\$0.00	\$72.12
	12/04/2028	\$46.90	\$9.65	\$17.07	\$0.00	\$73.62

For apprentice rates see "Apprentice- LABORER"

COMPRESSOR OPERATOR <i>OPERATING ENGINEERS LOCAL 98</i>	12/01/2023	\$39.03	\$13.78	\$15.15	\$0.00	\$67.96
---	------------	---------	---------	---------	--------	---------

For apprentice rates see "Apprentice- OPERATING ENGINEERS"

CRANE OPERATOR <i>OPERATING ENGINEERS LOCAL 98</i>	12/01/2023	\$43.06	\$13.78	\$15.15	\$0.00	\$71.99
--	------------	---------	---------	---------	--------	---------

For apprentice rates see "Apprentice- OPERATING ENGINEERS"

DELEADER (BRIDGE) <i>PAINTERS LOCAL 35 - ZONE 3</i>	07/01/2024	\$57.26	\$9.95	\$23.95	\$0.00	\$91.16
	01/01/2025	\$58.46	\$9.95	\$23.95	\$0.00	\$92.36

Classification

Effective Date Base Wage Health Pension Supplemental Unemployment Total Rate

Apprentice - PAINTER Local 35 - BRIDGES/TANKS

Effective Date - 07/01/2024

Step	percent	Apprentice Base Wage	Health	Pension	Supplemental Unemployment	Total Rate
1	50	\$28.63	\$9.95	\$0.00	\$0.00	\$38.58
2	55	\$31.49	\$9.95	\$6.66	\$0.00	\$48.10
3	60	\$34.36	\$9.95	\$7.26	\$0.00	\$51.57
4	65	\$37.22	\$9.95	\$7.87	\$0.00	\$55.04
5	70	\$40.08	\$9.95	\$20.32	\$0.00	\$70.35
6	75	\$42.95	\$9.95	\$20.93	\$0.00	\$73.83
7	80	\$45.81	\$9.95	\$21.53	\$0.00	\$77.29
8	90	\$51.53	\$9.95	\$22.74	\$0.00	\$84.22

Effective Date - 01/01/2025

Step	percent	Apprentice Base Wage	Health	Pension	Supplemental Unemployment	Total Rate
1	50	\$29.23	\$9.95	\$0.00	\$0.00	\$39.18
2	55	\$32.15	\$9.95	\$6.66	\$0.00	\$48.76
3	60	\$35.08	\$9.95	\$7.26	\$0.00	\$52.29
4	65	\$38.00	\$9.95	\$7.87	\$0.00	\$55.82
5	70	\$40.92	\$9.95	\$20.32	\$0.00	\$71.19
6	75	\$43.85	\$9.95	\$20.93	\$0.00	\$74.73
7	80	\$46.77	\$9.95	\$21.53	\$0.00	\$78.25
8	90	\$52.61	\$9.95	\$22.74	\$0.00	\$85.30

Notes:

Steps are 750 hrs.

Apprentice to Journeyworker Ratio:1:1

DEMO: ADZEMAN	12/02/2024	\$47.00	\$9.65	\$18.40	\$0.00	\$75.05
LABORERS - ZONE 3 (BUILDING & SITE)	06/02/2025	\$48.50	\$9.65	\$18.40	\$0.00	\$76.55
	12/01/2025	\$50.00	\$9.65	\$18.40	\$0.00	\$78.05
	06/01/2026	\$51.55	\$9.65	\$18.40	\$0.00	\$79.60
	12/07/2026	\$53.05	\$9.65	\$18.40	\$0.00	\$81.10
	06/07/2027	\$54.65	\$9.65	\$18.40	\$0.00	\$82.70
	12/06/2027	\$56.25	\$9.65	\$18.40	\$0.00	\$84.30
	06/05/2028	\$57.93	\$9.65	\$18.40	\$0.00	\$85.98
	12/04/2028	\$59.60	\$9.65	\$18.40	\$0.00	\$87.65

For apprentice rates see "Apprentice- LABORER"

Classification	Effective Date	Base Wage	Health	Pension	Supplemental Unemployment	Total Rate
DEMO: BACKHOE/LOADER/HAMMER OPERATOR <i>LABORERS - ZONE 3 (BUILDING & SITE)</i>	12/02/2024	\$48.00	\$9.65	\$18.40	\$0.00	\$76.05
	06/02/2025	\$49.50	\$9.65	\$18.40	\$0.00	\$77.55
	12/01/2025	\$51.00	\$9.65	\$18.40	\$0.00	\$79.05
	06/01/2026	\$52.55	\$9.65	\$18.40	\$0.00	\$80.60
	12/07/2026	\$54.05	\$9.65	\$18.40	\$0.00	\$82.10
	06/07/2027	\$55.65	\$9.65	\$18.40	\$0.00	\$83.70
	12/06/2027	\$57.25	\$9.65	\$18.40	\$0.00	\$85.30
	06/05/2028	\$58.93	\$9.65	\$18.40	\$0.00	\$86.98
	12/04/2028	\$60.60	\$9.65	\$18.40	\$0.00	\$88.65
For apprentice rates see "Apprentice- LABORER"						
DEMO: BURNERS <i>LABORERS - ZONE 3 (BUILDING & SITE)</i>	12/02/2024	\$47.75	\$9.65	\$18.40	\$0.00	\$75.80
	06/02/2025	\$49.25	\$9.65	\$18.40	\$0.00	\$77.30
	12/01/2025	\$50.75	\$9.65	\$18.40	\$0.00	\$78.80
	06/01/2026	\$52.30	\$9.65	\$18.40	\$0.00	\$80.35
	12/07/2026	\$53.80	\$9.65	\$18.40	\$0.00	\$81.85
	06/07/2027	\$55.40	\$9.65	\$18.40	\$0.00	\$83.45
	12/06/2027	\$57.00	\$9.65	\$18.40	\$0.00	\$85.05
	06/05/2028	\$58.68	\$9.65	\$18.40	\$0.00	\$86.73
	12/04/2028	\$60.35	\$9.65	\$18.40	\$0.00	\$88.40
For apprentice rates see "Apprentice- LABORER"						
DEMO: CONCRETE CUTTER/SAWYER <i>LABORERS - ZONE 3 (BUILDING & SITE)</i>	12/02/2024	\$48.00	\$9.65	\$18.40	\$0.00	\$76.05
	06/02/2025	\$49.50	\$9.65	\$18.40	\$0.00	\$77.55
	12/01/2025	\$51.00	\$9.65	\$18.40	\$0.00	\$79.05
	06/01/2026	\$52.55	\$9.65	\$18.40	\$0.00	\$80.60
	12/07/2026	\$54.05	\$9.65	\$18.40	\$0.00	\$82.10
	06/07/2027	\$55.65	\$9.65	\$18.40	\$0.00	\$83.70
	12/06/2027	\$57.25	\$9.65	\$18.40	\$0.00	\$85.30
	06/05/2028	\$58.93	\$9.65	\$18.40	\$0.00	\$86.98
	12/04/2028	\$60.60	\$9.65	\$18.40	\$0.00	\$88.65
For apprentice rates see "Apprentice- LABORER"						
DEMO: JACKHAMMER OPERATOR <i>LABORERS - ZONE 3 (BUILDING & SITE)</i>	12/02/2024	\$47.75	\$9.65	\$18.40	\$0.00	\$75.80
	06/02/2025	\$49.25	\$9.65	\$18.40	\$0.00	\$77.30
	12/01/2025	\$50.75	\$9.65	\$18.40	\$0.00	\$78.80
	06/01/2026	\$52.30	\$9.65	\$18.40	\$0.00	\$80.35
	12/07/2026	\$53.80	\$9.65	\$18.40	\$0.00	\$81.85
	06/07/2027	\$55.40	\$9.65	\$18.40	\$0.00	\$83.45
	12/06/2027	\$57.00	\$9.65	\$18.40	\$0.00	\$85.05
	06/05/2028	\$58.68	\$9.65	\$18.40	\$0.00	\$86.73
	12/04/2028	\$60.35	\$9.65	\$18.40	\$0.00	\$88.40
For apprentice rates see "Apprentice- LABORER"						

Classification	Effective Date	Base Wage	Health	Pension	Supplemental Unemployment	Total Rate
DEMO: WRECKING LABORER <i>LABORERS - ZONE 3 (BUILDING & SITE)</i>	12/02/2024	\$47.00	\$9.65	\$18.40	\$0.00	\$75.05
	06/02/2025	\$48.50	\$9.65	\$18.40	\$0.00	\$76.55
	12/01/2025	\$50.00	\$9.65	\$18.40	\$0.00	\$78.05
	06/01/2026	\$51.55	\$9.65	\$18.40	\$0.00	\$79.60
	12/07/2026	\$53.05	\$9.65	\$18.40	\$0.00	\$81.10
	06/07/2027	\$54.65	\$9.65	\$18.40	\$0.00	\$82.70
	12/06/2027	\$56.25	\$9.65	\$18.40	\$0.00	\$84.30
	06/05/2028	\$57.93	\$9.65	\$18.40	\$0.00	\$85.98
	12/04/2028	\$59.60	\$9.65	\$18.40	\$0.00	\$87.65
For apprentice rates see "Apprentice- LABORER"						
DIVER <i>PILE DRIVER LOCAL 56 (ZONE 3)</i>	08/01/2024	\$78.11	\$10.08	\$24.29	\$0.00	\$112.48
as of 8-1-24, Apprentices with diving licenses begin at second year. % of Diver wage 70/80/90 2A \$69.83, 3A \$91.79,4A \$102.14 Total Rate						
DIVER TENDER <i>PILE DRIVER LOCAL 56 (ZONE 3)</i>	08/01/2024	\$49.19	\$10.08	\$24.29	\$0.00	\$83.56
as of 8-1-24, Apprentices with diving licenses begin at second year. % of Piledriver wage 70/80/90 2A \$54.20, 3A \$73.93,4A \$82.05 Total Rate						
DIVER TENDER (EFFLUENT) <i>PILE DRIVER LOCAL 56 (ZONE 3)</i>	08/01/2024	\$83.69	\$10.08	\$24.29	\$0.00	\$118.06
For apprentice rates see "Apprentice- PILE DRIVER"						
DIVER/SLURRY (EFFLUENT) <i>PILE DRIVER LOCAL 56 (ZONE 3)</i>	08/01/2024	\$117.16	\$10.08	\$24.29	\$0.00	\$151.53
For apprentice rates see "Apprentice- PILE DRIVER"						
DRAWBRIDGE OPERATOR (Construction) <i>DRAWBRIDGE - SEIU LOCAL 888</i>	07/01/2020	\$26.77	\$6.67	\$3.93	\$0.16	\$37.53
ELECTRICIAN (Including Core Drilling) <i>ELECTRICIANS LOCAL 7</i>	06/30/2024	\$50.01	\$13.00	\$14.86	\$0.00	\$77.87
	12/29/2024	\$51.06	\$13.25	\$15.06	\$0.00	\$79.37
	06/29/2025	\$52.16	\$13.50	\$15.21	\$0.00	\$80.87
	12/28/2025	\$53.26	\$13.75	\$15.36	\$0.00	\$82.37
	06/28/2026	\$54.41	\$14.00	\$15.46	\$0.00	\$83.87
	01/03/2027	\$55.56	\$14.25	\$15.56	\$0.00	\$85.37

Classification	Effective Date	Base Wage	Health	Pension	Supplemental Unemployment	Total Rate
-----------------------	-----------------------	------------------	---------------	----------------	----------------------------------	-------------------

Apprentice - ELEVATOR CONSTRUCTOR - Local 41

Effective Date - 01/01/2024

Step	percent	Apprentice Base Wage	Health	Pension	Supplemental Unemployment	Total Rate
1	50	\$30.99	\$16.18	\$0.00	\$0.00	\$47.17
2	55	\$34.09	\$16.18	\$20.96	\$0.00	\$71.23
3	65	\$40.29	\$16.18	\$20.96	\$0.00	\$77.43
4	70	\$43.39	\$16.18	\$20.96	\$0.00	\$80.53
5	80	\$49.58	\$16.18	\$20.96	\$0.00	\$86.72

Effective Date - 01/01/2025

Step	percent	Apprentice Base Wage	Health	Pension	Supplemental Unemployment	Total Rate
1	50	\$31.42	\$16.28	\$0.00	\$0.00	\$47.70
2	55	\$34.56	\$16.28	\$21.36	\$0.00	\$72.20
3	65	\$40.84	\$16.28	\$21.36	\$0.00	\$78.48
4	70	\$43.98	\$16.28	\$21.36	\$0.00	\$81.62
5	80	\$50.26	\$16.28	\$21.36	\$0.00	\$87.90

Notes:

Steps 1-2 are 6 mos.; Steps 3-5 are 1 year

Apprentice to Journeyworker Ratio:1:1

ELEVATOR CONSTRUCTOR HELPER <i>ELEVATOR CONSTRUCTORS LOCAL 41</i>	01/01/2024	\$43.39	\$16.18	\$20.96	\$0.00	\$80.53
	01/01/2025	\$43.98	\$16.28	\$21.36	\$0.00	\$81.62
	01/01/2026	\$44.58	\$16.38	\$21.76	\$0.00	\$82.72
	01/01/2027	\$45.17	\$16.48	\$22.16	\$0.00	\$83.81

For apprentice rates see "Apprentice - ELEVATOR CONSTRUCTOR"

FENCE & GUARD RAIL ERECTOR (HEAVY & HIGHWAY) <i>LABORERS - ZONE 3 (HEAVY & HIGHWAY)</i>	12/01/2024	\$36.00	\$9.65	\$15.06	\$0.00	\$60.71
	06/01/2025	\$37.25	\$9.65	\$15.06	\$0.00	\$61.96
	12/01/2025	\$38.49	\$9.65	\$15.06	\$0.00	\$63.20
	06/01/2026	\$39.79	\$9.65	\$15.06	\$0.00	\$64.50
	12/01/2026	\$41.08	\$9.65	\$15.06	\$0.00	\$65.79

For apprentice rates see "Apprentice- LABORER (Heavy and Highway)"

FIELD ENG.INST/ROD-BLDG,SITE,HVY/HWY <i>OPERATING ENGINEERS LOCAL 98</i>	06/01/1999	\$18.84	\$4.80	\$4.10	\$0.00	\$27.74
---	------------	---------	--------	--------	--------	---------

FIELD ENG.PARTY CHIEF:BLDG,SITE,HVY/HWY <i>OPERATING ENGINEERS LOCAL 98</i>	06/01/1999	\$21.33	\$4.80	\$4.10	\$0.00	\$30.23
--	------------	---------	--------	--------	--------	---------

FIELD ENG.SURVEY CHIEF-BLDG,SITE,HVY/HWY <i>OPERATING ENGINEERS LOCAL 98</i>	06/01/1999	\$22.33	\$4.80	\$4.10	\$0.00	\$31.23
---	------------	---------	--------	--------	--------	---------

FIRE ALARM INSTALLER <i>ELECTRICIANS LOCAL 7</i>	06/30/2024	\$50.01	\$13.00	\$14.86	\$0.00	\$77.87
	12/29/2024	\$51.06	\$13.25	\$15.06	\$0.00	\$79.37
	06/29/2025	\$52.16	\$13.50	\$15.21	\$0.00	\$80.87
	12/28/2025	\$53.26	\$13.75	\$15.36	\$0.00	\$82.37
	06/28/2026	\$54.41	\$14.00	\$15.46	\$0.00	\$83.87
	01/03/2027	\$55.56	\$14.25	\$15.56	\$0.00	\$85.37

For apprentice rates see "Apprentice- ELECTRICIAN"

Classification	Effective Date	Base Wage	Health	Pension	Supplemental Unemployment	Total Rate
FIRE ALARM REPAIR / MAINTENANCE / COMMISSIONING <i>ELECTRICIANS</i>	06/30/2024	\$50.01	\$13.00	\$14.86	\$0.00	\$77.87
<i>LOCAL 7</i>	12/29/2024	\$51.06	\$13.25	\$15.06	\$0.00	\$79.37
	06/29/2025	\$52.16	\$13.50	\$15.21	\$0.00	\$80.87
	12/28/2025	\$53.26	\$13.75	\$15.36	\$0.00	\$82.37
	06/28/2026	\$54.41	\$14.00	\$15.46	\$0.00	\$83.87
	01/03/2027	\$55.56	\$14.25	\$15.56	\$0.00	\$85.37
For apprentice rates see "Apprentice- TELECOMMUNICATIONS TECHNICIAN"						
FIREMAN <i>OPERATING ENGINEERS LOCAL 98</i>	12/01/2023	\$39.03	\$13.78	\$15.15	\$0.00	\$67.96

Apprentice - OPERATING ENGINEERS - Local 98 Class 3

Effective Date - 12/01/2023

Step	percent	Apprentice Base Wage	Health	Pension	Supplemental Unemployment	Total Rate
1	60	\$23.42	\$13.78	\$15.15	\$0.00	\$52.35
2	70	\$27.32	\$13.78	\$15.15	\$0.00	\$56.25
3	80	\$31.22	\$13.78	\$15.15	\$0.00	\$60.15
4	90	\$35.13	\$13.78	\$15.15	\$0.00	\$64.06

Notes:

Steps 1-2 are 1000 hrs.; Steps 3-4 are 2000 hrs.

Apprentice to Journeyworker Ratio:1:6

FLAGGER & SIGNALER (HEAVY & HIGHWAY) <i>LABORERS - ZONE 3 (HEAVY & HIGHWAY)</i>	12/01/2024	\$27.01	\$9.65	\$15.06	\$0.00	\$51.72
	06/01/2025	\$28.09	\$9.65	\$15.06	\$0.00	\$52.80
	12/01/2025	\$28.09	\$9.65	\$15.06	\$0.00	\$52.80
	06/01/2026	\$29.21	\$9.65	\$15.06	\$0.00	\$53.92
	12/01/2026	\$29.21	\$9.65	\$15.06	\$0.00	\$53.92
For apprentice rates see "Apprentice- LABORER (Heavy and Highway)"						
FLOORCOVERER <i>FLOORCOVERERS LOCAL 2168 ZONE III</i>	09/01/2024	\$42.36	\$7.91	\$18.15	\$0.00	\$68.42
	03/01/2025	\$43.26	\$7.91	\$18.15	\$0.00	\$69.32
	09/01/2025	\$44.21	\$7.91	\$18.15	\$0.00	\$70.27
	03/01/2026	\$45.11	\$7.91	\$18.15	\$0.00	\$71.17
	09/01/2026	\$46.06	\$7.91	\$18.15	\$0.00	\$72.12
	03/01/2027	\$46.96	\$7.91	\$18.15	\$0.00	\$73.02

Classification	Effective Date	Base Wage	Health	Pension	Supplemental Unemployment	Total Rate
-----------------------	-----------------------	------------------	---------------	----------------	----------------------------------	-------------------

Apprentice - FLOORCOVERER - Local 2168 Zone III

Effective Date - 09/01/2024

Step	percent	Apprentice Base Wage	Health	Pension	Supplemental Unemployment	Total Rate
1	50	\$21.18	\$7.91	\$1.38	\$0.00	\$30.47
2	55	\$23.30	\$7.91	\$1.38	\$0.00	\$32.59
3	60	\$25.42	\$7.91	\$2.76	\$0.00	\$36.09
4	65	\$27.53	\$7.91	\$2.76	\$0.00	\$38.20
5	70	\$29.65	\$7.91	\$15.39	\$0.00	\$52.95
6	75	\$31.77	\$7.91	\$15.39	\$0.00	\$55.07
7	80	\$33.89	\$7.91	\$16.77	\$0.00	\$58.57
8	85	\$36.01	\$7.91	\$16.77	\$0.00	\$60.69

Effective Date - 03/01/2025

Step	percent	Apprentice Base Wage	Health	Pension	Supplemental Unemployment	Total Rate
1	50	\$21.63	\$7.91	\$1.38	\$0.00	\$30.92
2	55	\$23.79	\$7.91	\$1.38	\$0.00	\$33.08
3	60	\$25.96	\$7.91	\$2.76	\$0.00	\$36.63
4	65	\$28.12	\$7.91	\$2.76	\$0.00	\$38.79
5	70	\$30.28	\$7.91	\$15.39	\$0.00	\$53.58
6	75	\$32.45	\$7.91	\$15.39	\$0.00	\$55.75
7	80	\$34.61	\$7.91	\$16.77	\$0.00	\$59.29
8	85	\$36.77	\$7.91	\$16.77	\$0.00	\$61.45

Notes: Steps are 750 hrs.
 % After 10/1/17; 45/45/55/55/70/70/80/80 (1500hr Steps)
 Step 1&2 \$26.72.24/ 3&4 \$32.11/ 5&6 \$50.75/ 7&8 \$56.14

Apprentice to Journeyworker Ratio:1:1

FORK LIFT <i>OPERATING ENGINEERS LOCAL 98</i>	12/01/2023	\$39.25	\$13.78	\$15.15	\$0.00	\$68.18
---	------------	---------	---------	---------	--------	---------

For apprentice rates see "Apprentice- OPERATING ENGINEERS"

GENERATORS/LIGHTING PLANTS <i>OPERATING ENGINEERS LOCAL 98</i>	12/01/2023	\$35.80	\$13.78	\$15.15	\$0.00	\$64.73
--	------------	---------	---------	---------	--------	---------

For apprentice rates see "Apprentice- OPERATING ENGINEERS"

GLAZIER (GLASS PLANK/AIR BARRIER/INTERIOR SYSTEMS) <i>GLAZIERS LOCAL 1333</i>	06/01/2020	\$39.18	\$10.80	\$10.45	\$0.00	\$60.43
---	------------	---------	---------	---------	--------	---------

Classification	Effective Date	Base Wage	Health	Pension	Supplemental Unemployment	Total Rate
Apprentice - GLAZIER - Local 1333						
Effective Date - 06/01/2020						
Step	percent	Apprentice Base Wage	Health	Pension	Supplemental Unemployment	Total Rate
1	50	\$19.59	\$10.80	\$1.80	\$0.00	\$32.19
2	56	\$22.04	\$10.80	\$1.80	\$0.00	\$34.64
3	63	\$24.49	\$10.80	\$2.45	\$0.00	\$37.74
4	69	\$26.94	\$10.80	\$2.45	\$0.00	\$40.19
5	75	\$29.39	\$10.80	\$3.15	\$0.00	\$43.34
6	81	\$31.83	\$10.80	\$3.15	\$0.00	\$45.78
7	88	\$34.28	\$10.80	\$10.45	\$0.00	\$55.53
8	94	\$36.73	\$10.80	\$10.45	\$0.00	\$57.98

Notes:

Apprentice to Journeyworker Ratio:1:3

GRADER/TRENCHING MACHINE/DERRICK <i>OPERATING ENGINEERS LOCAL 98</i>	12/01/2023	\$39.56	\$13.78	\$15.15	\$0.00	\$68.49
For apprentice rates see "Apprentice- OPERATING ENGINEERS"						
HVAC (DUCTWORK) <i>SHEETMETAL WORKERS LOCAL 63</i>	07/01/2024	\$40.98	\$12.20	\$18.74	\$2.13	\$74.05
	01/01/2025	\$42.23	\$12.20	\$18.74	\$2.13	\$75.30
For apprentice rates see "Apprentice- SHEET METAL WORKER"						
HVAC (ELECTRICAL CONTROLS) <i>ELECTRICIANS LOCAL 7</i>	06/30/2024	\$50.01	\$13.00	\$14.86	\$0.00	\$77.87
	12/29/2024	\$51.06	\$13.25	\$15.06	\$0.00	\$79.37
	06/29/2025	\$52.16	\$13.50	\$15.21	\$0.00	\$80.87
	12/28/2025	\$53.26	\$13.75	\$15.36	\$0.00	\$82.37
	06/28/2026	\$54.41	\$14.00	\$15.46	\$0.00	\$83.87
	01/03/2027	\$55.56	\$14.25	\$15.56	\$0.00	\$85.37
For apprentice rates see "Apprentice- ELECTRICIAN"						
HVAC (TESTING AND BALANCING - AIR) <i>SHEETMETAL WORKERS LOCAL 63</i>	07/01/2024	\$40.98	\$12.20	\$18.74	\$2.13	\$74.05
	01/01/2025	\$42.23	\$12.20	\$18.74	\$2.13	\$75.30
For apprentice rates see "Apprentice- SHEET METAL WORKER"						
HVAC (TESTING AND BALANCING - WATER) <i>PLUMBERS & PIPEFITTERS LOCAL 104</i>	03/17/2024	\$49.21	\$9.55	\$17.10	\$0.00	\$75.86
For apprentice rates see "Apprentice- PIPEFITTER" or "PLUMBER/PIPEFITTER"						
HVAC MECHANIC <i>PLUMBERS & PIPEFITTERS LOCAL 104</i>	03/17/2024	\$49.21	\$9.55	\$17.10	\$0.00	\$75.86
For apprentice rates see "Apprentice- PIPEFITTER" or "PLUMBER/PIPEFITTER"						
HYDRAULIC DRILLS (HEAVY & HIGHWAY) <i>LABORERS - ZONE 3 (HEAVY & HIGHWAY)</i>	12/01/2024	\$36.50	\$9.65	\$15.06	\$0.00	\$61.21
	06/01/2025	\$37.75	\$9.65	\$15.06	\$0.00	\$62.46
	12/01/2025	\$38.99	\$9.65	\$15.06	\$0.00	\$63.70
	06/01/2026	\$40.29	\$9.65	\$15.06	\$0.00	\$65.00
	12/01/2026	\$41.58	\$9.65	\$15.06	\$0.00	\$66.29
For apprentice rates see "Apprentice- LABORER (Heavy and Highway)"						

Classification	Effective Date	Base Wage	Health	Pension	Supplemental Unemployment	Total Rate
INSULATOR (PIPES & TANKS) <i>HEAT & FROST INSULATORS LOCAL 6 (SPRINGFIELD)</i>	09/01/2024	\$45.54	\$14.75	\$19.61	\$0.00	\$79.90
	09/01/2025	\$48.27	\$14.75	\$19.61	\$0.00	\$82.63
	09/01/2026	\$51.01	\$14.75	\$19.61	\$0.00	\$85.37

Apprentice - ASBESTOS INSULATOR (Pipes & Tanks) - Local 6 Springfield

Effective Date - 09/01/2024

Step	percent	Apprentice Base Wage	Health	Pension	Supplemental Unemployment	Total Rate
1	50	\$22.77	\$14.75	\$14.32	\$0.00	\$51.84
2	60	\$27.32	\$14.75	\$15.37	\$0.00	\$57.44
3	70	\$31.88	\$14.75	\$16.43	\$0.00	\$63.06
4	80	\$36.43	\$14.75	\$17.49	\$0.00	\$68.67

Effective Date - 09/01/2025

Step	percent	Apprentice Base Wage	Health	Pension	Supplemental Unemployment	Total Rate
1	50	\$24.14	\$14.75	\$14.32	\$0.00	\$53.21
2	60	\$28.96	\$14.75	\$15.37	\$0.00	\$59.08
3	70	\$33.79	\$14.75	\$16.43	\$0.00	\$64.97
4	80	\$38.62	\$14.75	\$17.49	\$0.00	\$70.86

Notes:

Steps are 1 year

Apprentice to Journeyworker Ratio:1:4

IRONWORKER/WELDER <i>IRONWORKERS LOCAL 7 (SPRINGFIELD AREA)</i>	03/16/2024	\$40.66	\$8.25	\$22.70	\$0.00	\$71.61
--	------------	---------	--------	---------	--------	---------

Apprentice - IRONWORKER - Local 7 Springfield

Effective Date - 03/16/2024

Step	percent	Apprentice Base Wage	Health	Pension	Supplemental Unemployment	Total Rate
1	60	\$24.40	\$8.25	\$22.70	\$0.00	\$55.35
2	70	\$28.46	\$8.25	\$22.70	\$0.00	\$59.41
3	75	\$30.50	\$8.25	\$22.70	\$0.00	\$61.45
4	80	\$32.53	\$8.25	\$22.70	\$0.00	\$63.48
5	85	\$34.56	\$8.25	\$22.70	\$0.00	\$65.51
6	90	\$36.59	\$8.25	\$22.70	\$0.00	\$67.54

Notes:

Apprentice to Journeyworker Ratio:1:4

Classification	Effective Date	Base Wage	Health	Pension	Supplemental Unemployment	Total Rate
JACKHAMMER & PAVING BREAKER OPERATOR <i>LABORERS - ZONE 3 (BUILDING & SITE)</i>	12/02/2024	\$36.00	\$9.65	\$17.07	\$0.00	\$62.72
	06/02/2025	\$37.25	\$9.65	\$17.07	\$0.00	\$63.97
	12/01/2025	\$38.50	\$9.65	\$17.07	\$0.00	\$65.22
	06/01/2026	\$39.80	\$9.65	\$17.07	\$0.00	\$66.52
	12/07/2026	\$41.10	\$9.65	\$17.07	\$0.00	\$67.82
	06/07/2027	\$42.50	\$9.65	\$17.07	\$0.00	\$69.22
	12/06/2027	\$43.90	\$9.65	\$17.07	\$0.00	\$70.62
	06/05/2028	\$45.40	\$9.65	\$17.07	\$0.00	\$72.12
	12/04/2028	\$46.90	\$9.65	\$17.07	\$0.00	\$73.62

For apprentice rates see "Apprentice- LABORER"

LABORER <i>LABORERS - ZONE 3 (BUILDING & SITE)</i>	12/02/2024	\$35.75	\$9.65	\$17.07	\$0.00	\$62.47
	06/02/2025	\$37.00	\$9.65	\$17.07	\$0.00	\$63.72
	12/01/2025	\$38.25	\$9.65	\$17.07	\$0.00	\$64.97
	06/01/2026	\$39.55	\$9.65	\$17.07	\$0.00	\$66.27
	12/07/2026	\$40.85	\$9.65	\$17.07	\$0.00	\$67.57
	06/07/2027	\$42.25	\$9.65	\$17.07	\$0.00	\$68.97
	12/06/2027	\$43.65	\$9.65	\$17.07	\$0.00	\$70.37
	06/05/2028	\$45.15	\$9.65	\$17.07	\$0.00	\$71.87
	12/04/2028	\$46.65	\$9.65	\$17.07	\$0.00	\$73.37

Apprentice - LABORER - Zone 3 Building & Site

Effective Date - 12/02/2024

Step	percent	Apprentice Base Wage	Health	Pension	Supplemental Unemployment	Total Rate
1	60	\$21.45	\$9.65	\$17.07	\$0.00	\$48.17
2	70	\$25.03	\$9.65	\$17.07	\$0.00	\$51.75
3	80	\$28.60	\$9.65	\$17.07	\$0.00	\$55.32
4	90	\$32.18	\$9.65	\$17.07	\$0.00	\$58.90

Effective Date - 06/02/2025

Step	percent	Apprentice Base Wage	Health	Pension	Supplemental Unemployment	Total Rate
1	60	\$22.20	\$9.65	\$17.07	\$0.00	\$48.92
2	70	\$25.90	\$9.65	\$17.07	\$0.00	\$52.62
3	80	\$29.60	\$9.65	\$17.07	\$0.00	\$56.32
4	90	\$33.30	\$9.65	\$17.07	\$0.00	\$60.02

Notes:

Apprentice to Journeyworker Ratio:1:5

LABORER (HEAVY & HIGHWAY) <i>LABORERS - ZONE 3 (HEAVY & HIGHWAY)</i>	12/01/2024	\$35.75	\$9.65	\$15.06	\$0.00	\$60.46
	06/01/2025	\$37.00	\$9.65	\$15.06	\$0.00	\$61.71
	12/01/2025	\$38.24	\$9.65	\$15.06	\$0.00	\$62.95
	06/01/2026	\$39.54	\$9.65	\$15.06	\$0.00	\$64.25
	12/01/2026	\$40.83	\$9.65	\$15.06	\$0.00	\$65.54

Classification

Effective Date Base Wage Health Pension Supplemental Unemployment Total Rate

Apprentice - LABORER (Heavy & Highway) - Zone 3

Effective Date - 12/01/2024

Step	percent	Apprentice Base Wage	Health	Pension	Supplemental Unemployment	Total Rate
1	60	\$21.45	\$9.65	\$15.06	\$0.00	\$46.16
2	70	\$25.03	\$9.65	\$15.06	\$0.00	\$49.74
3	80	\$28.60	\$9.65	\$15.06	\$0.00	\$53.31
4	90	\$32.18	\$9.65	\$15.06	\$0.00	\$56.89

Effective Date - 06/01/2025

Step	percent	Apprentice Base Wage	Health	Pension	Supplemental Unemployment	Total Rate
1	60	\$22.20	\$9.65	\$15.06	\$0.00	\$46.91
2	70	\$25.90	\$9.65	\$15.06	\$0.00	\$50.61
3	80	\$29.60	\$9.65	\$15.06	\$0.00	\$54.31
4	90	\$33.30	\$9.65	\$15.06	\$0.00	\$58.01

Notes:

Apprentice to Journeyworker Ratio:1:5

LABORER: CARPENTER TENDER	12/02/2024	\$35.75	\$9.65	\$17.07	\$0.00	\$62.47
<i>LABORERS - ZONE 3 (BUILDING & SITE)</i>	06/02/2025	\$37.00	\$9.65	\$17.07	\$0.00	\$63.72
	12/01/2025	\$38.25	\$9.65	\$17.07	\$0.00	\$64.97
	06/01/2026	\$39.55	\$9.65	\$17.07	\$0.00	\$66.27
	12/07/2026	\$40.85	\$9.65	\$17.07	\$0.00	\$67.57
	06/07/2027	\$42.25	\$9.65	\$17.07	\$0.00	\$68.97
	12/06/2027	\$43.65	\$9.65	\$17.07	\$0.00	\$70.37
	06/05/2028	\$45.15	\$9.65	\$17.07	\$0.00	\$71.87
	12/04/2028	\$46.65	\$9.65	\$17.07	\$0.00	\$73.37

For apprentice rates see "Apprentice- LABORER"

LABORER: CEMENT FINISHER TENDER	12/02/2024	\$35.75	\$9.65	\$17.07	\$0.00	\$62.47
<i>LABORERS - ZONE 3 (BUILDING & SITE)</i>	06/02/2025	\$37.00	\$9.65	\$17.07	\$0.00	\$63.72
	12/01/2025	\$38.25	\$9.65	\$17.07	\$0.00	\$64.97
	06/01/2026	\$39.55	\$9.65	\$17.07	\$0.00	\$66.27
	12/07/2026	\$40.85	\$9.65	\$17.07	\$0.00	\$67.57
	06/07/2027	\$42.25	\$9.65	\$17.07	\$0.00	\$68.97
	12/06/2027	\$43.65	\$9.65	\$17.07	\$0.00	\$70.37
	06/05/2028	\$45.15	\$9.65	\$17.07	\$0.00	\$71.87
	12/04/2028	\$46.65	\$9.65	\$17.07	\$0.00	\$73.37

For apprentice rates see "Apprentice- LABORER"

Classification	Effective Date	Base Wage	Health	Pension	Supplemental Unemployment	Total Rate
LABORER: HAZARDOUS WASTE/ASBESTOS REMOVER <i>LABORERS - ZONE 3 (BUILDING & SITE)</i>	12/02/2024	\$35.67	\$9.65	\$17.20	\$0.00	\$62.52
	06/02/2025	\$36.92	\$9.65	\$17.20	\$0.00	\$63.77
	12/01/2025	\$38.17	\$9.65	\$17.20	\$0.00	\$65.02
	06/01/2026	\$39.47	\$9.65	\$17.20	\$0.00	\$66.32
	12/07/2026	\$40.77	\$9.65	\$17.20	\$0.00	\$67.62
	06/07/2027	\$42.17	\$9.65	\$17.20	\$0.00	\$69.02
	12/06/2027	\$43.57	\$9.65	\$17.20	\$0.00	\$70.42
	06/05/2028	\$45.07	\$9.65	\$17.20	\$0.00	\$71.92
	12/04/2028	\$46.57	\$9.65	\$17.20	\$0.00	\$73.42
For apprentice rates see "Apprentice- LABORER"						
LABORER: MASON TENDER <i>LABORERS - ZONE 3 (BUILDING & SITE)</i>	12/02/2024	\$38.75	\$9.65	\$17.07	\$0.00	\$65.47
	06/02/2025	\$40.00	\$9.65	\$17.07	\$0.00	\$66.72
	12/01/2025	\$41.25	\$9.65	\$17.07	\$0.00	\$67.97
	06/01/2026	\$42.55	\$9.65	\$17.07	\$0.00	\$69.27
	12/07/2026	\$43.85	\$9.65	\$17.07	\$0.00	\$70.57
	06/07/2027	\$45.25	\$9.65	\$17.07	\$0.00	\$71.97
	12/06/2027	\$46.65	\$9.65	\$17.07	\$0.00	\$73.37
	06/05/2028	\$48.15	\$9.65	\$17.07	\$0.00	\$74.87
	12/04/2028	\$49.65	\$9.65	\$17.07	\$0.00	\$76.37
For apprentice rates see "Apprentice- LABORER"						
LABORER: MASON TENDER (HEAVY & HIGHWAY) <i>LABORERS - ZONE 3 (HEAVY & HIGHWAY)</i>	12/01/2024	\$36.00	\$9.65	\$15.06	\$0.00	\$60.71
	06/01/2025	\$37.25	\$9.65	\$15.06	\$0.00	\$61.96
	12/01/2025	\$38.49	\$9.65	\$15.06	\$0.00	\$63.20
	06/01/2026	\$39.79	\$9.65	\$15.06	\$0.00	\$64.50
	12/01/2026	\$41.08	\$9.65	\$15.06	\$0.00	\$65.79
For apprentice rates see "Apprentice- LABORER (Heavy and Highway)"						
LABORER: MULTI-TRADE TENDER <i>LABORERS - ZONE 3 (BUILDING & SITE)</i>	12/02/2024	\$35.75	\$9.65	\$17.07	\$0.00	\$62.47
	06/02/2025	\$37.00	\$9.65	\$17.07	\$0.00	\$63.72
	12/01/2025	\$38.25	\$9.65	\$17.07	\$0.00	\$64.97
	06/01/2026	\$39.55	\$9.65	\$17.07	\$0.00	\$66.27
	12/07/2026	\$40.85	\$9.65	\$17.07	\$0.00	\$67.57
	06/07/2027	\$42.25	\$9.65	\$17.07	\$0.00	\$68.97
	12/06/2027	\$43.65	\$9.65	\$17.07	\$0.00	\$70.37
	06/05/2028	\$45.15	\$9.65	\$17.07	\$0.00	\$71.87
	12/04/2028	\$46.65	\$9.65	\$17.07	\$0.00	\$73.37
For apprentice rates see "Apprentice- LABORER"						
LABORER: TREE REMOVER <i>LABORERS - ZONE 3 (BUILDING & SITE)</i>	12/02/2024	\$35.75	\$9.65	\$17.07	\$0.00	\$62.47
	06/02/2025	\$37.00	\$9.65	\$17.07	\$0.00	\$63.72
	12/01/2025	\$38.25	\$9.65	\$17.07	\$0.00	\$64.97
	06/01/2026	\$39.55	\$9.65	\$17.07	\$0.00	\$66.27
	12/07/2026	\$40.85	\$9.65	\$17.07	\$0.00	\$67.57
	06/07/2027	\$42.25	\$9.65	\$17.07	\$0.00	\$68.97
	12/06/2027	\$43.65	\$9.65	\$17.07	\$0.00	\$70.37
	06/05/2028	\$45.15	\$9.65	\$17.07	\$0.00	\$71.87
	12/04/2028	\$46.65	\$9.65	\$17.07	\$0.00	\$73.37

This classification applies to the removal of standing trees, and the trimming and removal of branches and limbs when related to public works construction or site clearance incidental to construction . For apprentice rates see "Apprentice- LABORER"

Classification	Effective Date	Base Wage	Health	Pension	Supplemental Unemployment	Total Rate
LASER BEAM OPERATOR <i>LABORERS - ZONE 3 (BUILDING & SITE)</i>	12/02/2024	\$36.00	\$9.65	\$17.07	\$0.00	\$62.72
	06/02/2025	\$37.25	\$9.65	\$17.07	\$0.00	\$63.97
	12/01/2025	\$38.50	\$9.65	\$17.07	\$0.00	\$65.22
	06/01/2026	\$39.80	\$9.65	\$17.07	\$0.00	\$66.52
	12/07/2026	\$41.10	\$9.65	\$17.07	\$0.00	\$67.82
	06/07/2027	\$42.50	\$9.65	\$17.07	\$0.00	\$69.22
	12/06/2027	\$43.90	\$9.65	\$17.07	\$0.00	\$70.62
	06/05/2028	\$45.40	\$9.65	\$17.07	\$0.00	\$72.12
	12/04/2028	\$46.90	\$9.65	\$17.07	\$0.00	\$73.62

For apprentice rates see "Apprentice- LABORER"

LASER BEAM OPERATOR (HEAVY & HIGHWAY) <i>LABORERS - ZONE 3 (HEAVY & HIGHWAY)</i>	12/01/2024	\$36.00	\$9.65	\$15.06	\$0.00	\$60.71
	06/01/2025	\$37.25	\$9.65	\$15.06	\$0.00	\$61.96
	12/01/2025	\$38.49	\$9.65	\$15.06	\$0.00	\$63.20
	06/01/2026	\$39.79	\$9.65	\$15.06	\$0.00	\$64.50
	12/01/2026	\$41.08	\$9.65	\$15.06	\$0.00	\$65.79

For apprentice rates see "Apprentice- LABORER (Heavy and Highway)"

MARBLE & TILE FINISHERS <i>BRICKLAYERS LOCAL 3 (SPR/PITT) - MARBLE & TILE</i>	08/01/2024	\$43.05	\$11.49	\$20.53	\$0.00	\$75.07
	02/01/2025	\$44.90	\$11.49	\$20.53	\$0.00	\$76.92
	08/01/2025	\$45.81	\$11.49	\$20.53	\$0.00	\$77.83
	02/01/2026	\$46.89	\$11.49	\$20.53	\$0.00	\$78.91
	08/01/2026	\$48.65	\$11.49	\$20.53	\$0.00	\$80.67
	02/01/2027	\$49.77	\$11.49	\$20.53	\$0.00	\$81.79

Apprentice - MARBLE-TILE FINISHER-Local 3 Marble/Tile (Spr/Pitt)

Effective Date - 08/01/2024

Step	percent	Apprentice Base Wage	Health	Pension	Supplemental Unemployment	Total Rate
1	50	\$21.53	\$11.49	\$20.53	\$0.00	\$53.55
2	60	\$25.83	\$11.49	\$20.53	\$0.00	\$57.85
3	70	\$30.14	\$11.49	\$20.53	\$0.00	\$62.16
4	80	\$34.44	\$11.49	\$20.53	\$0.00	\$66.46
5	90	\$38.75	\$11.49	\$20.53	\$0.00	\$70.77

Effective Date - 02/01/2025

Step	percent	Apprentice Base Wage	Health	Pension	Supplemental Unemployment	Total Rate
1	50	\$22.45	\$11.49	\$20.53	\$0.00	\$54.47
2	60	\$26.94	\$11.49	\$20.53	\$0.00	\$58.96
3	70	\$31.43	\$11.49	\$20.53	\$0.00	\$63.45
4	80	\$35.92	\$11.49	\$20.53	\$0.00	\$67.94
5	90	\$40.41	\$11.49	\$20.53	\$0.00	\$72.43

Notes:

Apprentice to Journeyworker Ratio:1:5

MARBLE MASON/TILE LAYER(SP/PT)SeeBrick
BRICKLAYERS LOCAL 3 (SPR/PITT) - MARBLE & TILE

Classification	Effective Date	Base Wage	Health	Pension	Supplemental Unemployment	Total Rate
See "BRICK/STONE/ARTIFICIAL MASONRY(INCL.MASONRY WATERPROOFING)						
MECH. SWEEPER OPERATOR (ON CONST. SITES) <i>OPERATING ENGINEERS LOCAL 98</i>	12/01/2023	\$39.56	\$13.78	\$15.15	\$0.00	\$68.49
For apprentice rates see "Apprentice- OPERATING ENGINEERS"						
MECHANIC/WELDER/BOOM TRUCK <i>OPERATING ENGINEERS LOCAL 98</i>	12/01/2023	\$39.03	\$13.78	\$15.15	\$0.00	\$67.96
For apprentice rates see "Apprentice- OPERATING ENGINEERS"						
MILLWRIGHT (Zone 3) <i>MILLWRIGHTS LOCAL 1121 - Zone 3</i>	01/01/2024	\$41.20	\$10.08	\$21.22	\$0.00	\$72.50
	01/06/2025	\$43.48	\$10.08	\$21.22	\$0.00	\$74.78
	01/05/2026	\$45.76	\$10.08	\$21.22	\$0.00	\$77.06

Apprentice - MILLWRIGHT - Local 1121 Zone 3

Effective Date - 01/01/2024

Step	percent	Apprentice Base Wage	Health	Pension	Supplemental Unemployment	Total Rate
1	55	\$22.66	\$10.08	\$5.36	\$0.00	\$38.10
2	65	\$26.78	\$10.08	\$6.34	\$0.00	\$43.20
3	75	\$30.90	\$10.08	\$18.78	\$0.00	\$59.76
4	85	\$35.02	\$10.08	\$19.76	\$0.00	\$64.86

Effective Date - 01/06/2025

Step	percent	Apprentice Base Wage	Health	Pension	Supplemental Unemployment	Total Rate
1	55	\$23.91	\$10.08	\$5.36	\$0.00	\$39.35
2	65	\$28.26	\$10.08	\$6.34	\$0.00	\$44.68
3	75	\$32.61	\$10.08	\$18.78	\$0.00	\$61.47
4	85	\$36.96	\$10.08	\$19.76	\$0.00	\$66.80

Notes: Step 1&2 Appr. indentured after 1/6/2020 receive no pension, but do receive annuity. (Step 1 \$5.72, Step 2 \$6.66)
Steps are 2,000 hours

Apprentice to Journeyworker Ratio:1:4

MORTAR MIXER <i>LABORERS - ZONE 3 (BUILDING & SITE)</i>	12/02/2024	\$36.00	\$9.65	\$17.07	\$0.00	\$62.72
	06/02/2025	\$37.25	\$9.65	\$17.07	\$0.00	\$63.97
	12/01/2025	\$38.50	\$9.65	\$17.07	\$0.00	\$65.22
	06/01/2026	\$39.80	\$9.65	\$17.07	\$0.00	\$66.52
	12/07/2026	\$41.10	\$9.65	\$17.07	\$0.00	\$67.82
	06/07/2027	\$42.50	\$9.65	\$17.07	\$0.00	\$69.22
	12/06/2027	\$43.90	\$9.65	\$17.07	\$0.00	\$70.62
	06/05/2028	\$45.40	\$9.65	\$17.07	\$0.00	\$72.12
	12/04/2028	\$46.90	\$9.65	\$17.07	\$0.00	\$73.62
For apprentice rates see "Apprentice- LABORER"						
OILER <i>OPERATING ENGINEERS LOCAL 98</i>	12/01/2023	\$35.02	\$13.78	\$15.15	\$0.00	\$63.95
For apprentice rates see "Apprentice- OPERATING ENGINEERS"						
OTHER POWER DRIVEN EQUIPMENT - CLASS VI <i>OPERATING ENGINEERS LOCAL 98</i>	12/01/2023	\$32.74	\$13.78	\$15.15	\$0.00	\$61.67
For apprentice rates see "Apprentice- OPERATING ENGINEERS"						
Painter (BRIDGES/TANKS) <i>PAINTERS LOCAL 35 - ZONE 3</i>	07/01/2024	\$57.26	\$9.95	\$23.95	\$0.00	\$91.16
	01/01/2025	\$58.46	\$9.95	\$23.95	\$0.00	\$92.36

Classification

Effective Date Base Wage Health Pension Supplemental Unemployment Total Rate

Apprentice - PAINTER Local 35 Zone 3 - Spray/Sandblast - New

Effective Date - 07/01/2024

Step	percent	Apprentice Base Wage	Health	Pension	Supplemental Unemployment	Total Rate
1	50	\$20.02	\$9.95	\$0.00	\$0.00	\$29.97
2	55	\$22.02	\$9.95	\$4.43	\$0.00	\$36.40
3	60	\$24.02	\$9.95	\$4.83	\$0.00	\$38.80
4	65	\$26.02	\$9.95	\$5.23	\$0.00	\$41.20
5	70	\$28.02	\$9.95	\$17.49	\$0.00	\$55.46
6	75	\$30.02	\$9.95	\$17.89	\$0.00	\$57.86
7	80	\$32.02	\$9.95	\$18.29	\$0.00	\$60.26
8	90	\$36.03	\$9.95	\$19.10	\$0.00	\$65.08

Effective Date - 01/01/2025

Step	percent	Apprentice Base Wage	Health	Pension	Supplemental Unemployment	Total Rate
1	50	\$20.62	\$9.95	\$0.00	\$0.00	\$30.57
2	55	\$22.68	\$9.95	\$4.43	\$0.00	\$37.06
3	60	\$24.74	\$9.95	\$4.83	\$0.00	\$39.52
4	65	\$26.80	\$9.95	\$5.23	\$0.00	\$41.98
5	70	\$28.86	\$9.95	\$17.49	\$0.00	\$56.30
6	75	\$30.92	\$9.95	\$17.89	\$0.00	\$58.76
7	80	\$32.98	\$9.95	\$18.29	\$0.00	\$61.22
8	90	\$37.11	\$9.95	\$19.10	\$0.00	\$66.16

Notes:

Steps are 750 hrs.

Apprentice to Journeyworker Ratio:1:1

PAINTER (SPRAY OR SANDBLAST, REPAINT)	07/01/2024	\$37.35	\$9.95	\$19.90	\$0.00	\$67.20
PAINTERS LOCAL 35 - ZONE 3	01/01/2025	\$38.55	\$9.95	\$19.90	\$0.00	\$68.40

Classification

Effective Date Base Wage Health Pension Supplemental Unemployment Total Rate

Apprentice - PAINTER Local 35 Zone 3 - Spray/Sandblast - Repaint

Effective Date - 07/01/2024

Step	percent	Apprentice Base Wage	Health	Pension	Supplemental Unemployment	Total Rate
1	50	\$18.68	\$9.95	\$0.00	\$0.00	\$28.63
2	55	\$20.54	\$9.95	\$4.43	\$0.00	\$34.92
3	60	\$22.41	\$9.95	\$4.83	\$0.00	\$37.19
4	65	\$24.28	\$9.95	\$5.23	\$0.00	\$39.46
5	70	\$26.15	\$9.95	\$17.49	\$0.00	\$53.59
6	75	\$28.01	\$9.95	\$17.89	\$0.00	\$55.85
7	80	\$29.88	\$9.95	\$18.29	\$0.00	\$58.12
8	90	\$33.62	\$9.95	\$19.10	\$0.00	\$62.67

Effective Date - 01/01/2025

Step	percent	Apprentice Base Wage	Health	Pension	Supplemental Unemployment	Total Rate
1	50	\$19.28	\$9.95	\$0.00	\$0.00	\$29.23
2	55	\$21.20	\$9.95	\$4.43	\$0.00	\$35.58
3	60	\$23.13	\$9.95	\$4.83	\$0.00	\$37.91
4	65	\$25.06	\$9.95	\$5.23	\$0.00	\$40.24
5	70	\$26.99	\$9.95	\$17.49	\$0.00	\$54.43
6	75	\$28.91	\$9.95	\$17.89	\$0.00	\$56.75
7	80	\$30.84	\$9.95	\$18.29	\$0.00	\$59.08
8	90	\$34.70	\$9.95	\$19.10	\$0.00	\$63.75

Notes:
Steps are 750 hrs.

Apprentice to Journeyworker Ratio:1:1

PAINTER / TAPER (BRUSH, NEW) *	07/01/2024	\$38.63	\$9.95	\$19.90	\$0.00	\$68.48
* If 30% or more of surfaces to be painted are new construction, NEW paint rate shall be used. PAINTERS LOCAL 35 - ZONE 3	01/01/2025	\$39.83	\$9.95	\$19.90	\$0.00	\$69.68

Classification	Effective Date	Base Wage	Health	Pension	Supplemental Unemployment	Total Rate
PILE DRIVER <i>PILE DRIVER LOCAL 56 (ZONE 3)</i>	08/01/2024	\$49.19	\$10.08	\$24.29	\$0.00	\$83.56

Apprentice - PILE DRIVER - Local 56 Zone 3

Effective Date - 08/01/2024

Step	percent	Apprentice Base Wage	Health	Pension	Supplemental Unemployment	Total Rate
1	45	\$22.14	\$10.08	\$2.53	\$0.00	\$34.75
2	55	\$27.05	\$10.08	\$5.07	\$0.00	\$42.20
3	70	\$34.43	\$10.08	\$19.22	\$0.00	\$63.73
4	80	\$39.35	\$10.08	\$21.76	\$0.00	\$71.19

Notes:

% Indentured BEFORE 8/1/2020, 50/60/70/75/80/80/90/90
1\$58.97/2\$63.88/3\$68.80/4\$71.26/5&6 \$73.72/7&8 \$78.64

Apprentice to Journeyworker Ratio:1:5

PIPELAYER <i>LABORERS - ZONE 3 (BUILDING & SITE)</i>	12/02/2024	\$36.00	\$9.65	\$17.07	\$0.00	\$62.72
	06/02/2025	\$37.25	\$9.65	\$17.07	\$0.00	\$63.97
	12/01/2025	\$38.50	\$9.65	\$17.07	\$0.00	\$65.22
	06/01/2026	\$39.80	\$9.65	\$17.07	\$0.00	\$66.52
	12/07/2026	\$41.10	\$9.65	\$17.07	\$0.00	\$67.82
	06/07/2027	\$42.50	\$9.65	\$17.07	\$0.00	\$69.22
	12/06/2027	\$43.90	\$9.65	\$17.07	\$0.00	\$70.62
	06/05/2028	\$45.40	\$9.65	\$17.07	\$0.00	\$72.12
	12/04/2028	\$46.90	\$9.65	\$17.07	\$0.00	\$73.62

For apprentice rates see "Apprentice- LABORER"

PIPELAYER (HEAVY & HIGHWAY) <i>LABORERS - ZONE 3 (HEAVY & HIGHWAY)</i>	12/01/2024	\$36.00	\$9.65	\$15.06	\$0.00	\$60.71
	06/01/2025	\$37.25	\$9.65	\$15.06	\$0.00	\$61.96
	12/01/2025	\$38.49	\$9.65	\$15.06	\$0.00	\$63.20
	06/01/2026	\$39.79	\$9.65	\$15.06	\$0.00	\$64.50
	12/01/2026	\$41.08	\$9.65	\$15.06	\$0.00	\$65.79

For apprentice rates see "Apprentice- LABORER (Heavy and Highway)"

PLUMBER & PIPEFITTER <i>PLUMBERS & PIPEFITTERS LOCAL 104</i>	03/17/2024	\$49.21	\$9.55	\$17.10	\$0.00	\$75.86
---	------------	---------	--------	---------	--------	---------

Classification	Effective Date	Base Wage	Health	Pension	Supplemental Unemployment	Total Rate
-----------------------	-----------------------	------------------	---------------	----------------	----------------------------------	-------------------

Apprentice - PLUMBER/PIPEFITTER - Local 104

Effective Date - 03/17/2024

Step	percent	Apprentice Base Wage	Health	Pension	Supplemental Unemployment	Total Rate
1	45	\$22.14	\$9.55	\$10.10	\$0.00	\$41.79
2	50	\$24.61	\$9.55	\$10.10	\$0.00	\$44.26
3	55	\$27.07	\$9.55	\$10.10	\$0.00	\$46.72
4	60	\$29.53	\$9.55	\$10.10	\$0.00	\$49.18
5	65	\$31.99	\$9.55	\$10.10	\$0.00	\$51.64
6	70	\$34.45	\$9.55	\$10.10	\$0.00	\$54.10
7	75	\$36.91	\$9.55	\$10.10	\$0.00	\$56.56
8	80	\$39.37	\$9.55	\$10.10	\$0.00	\$59.02
9	80	\$39.37	\$9.55	\$17.10	\$0.00	\$66.02
10	80	\$39.37	\$9.55	\$17.10	\$0.00	\$66.02

Notes: **1:1,2:5,3:9,4:12

Apprentice to Journeyworker Ratio:**

PNEUMATIC CONTROLS (TEMP.) <i>PLUMBERS & PIPEFITTERS LOCAL 104</i>	03/17/2024	\$49.21	\$9.55	\$17.10	\$0.00	\$75.86
---	------------	---------	--------	---------	--------	---------

For apprentice rates see "Apprentice- PIPEFITTER" or "PLUMBER/PIPEFITTER"

PNEUMATIC DRILL/TOOL OPERATOR (HEAVY & HIGHWAY) <i>LABORERS - ZONE 3 (HEAVY & HIGHWAY)</i>	12/01/2024	\$36.00	\$9.65	\$15.06	\$0.00	\$60.71
	06/01/2025	\$37.25	\$9.65	\$15.06	\$0.00	\$61.96
	12/01/2025	\$38.49	\$9.65	\$15.06	\$0.00	\$63.20
	06/01/2026	\$39.79	\$9.65	\$15.06	\$0.00	\$64.50
	12/01/2026	\$41.08	\$9.65	\$15.06	\$0.00	\$65.79

For apprentice rates see "Apprentice- LABORER (Heavy and Highway)"

POWDERMAN & BLASTER <i>LABORERS - ZONE 3 (BUILDING & SITE)</i>	12/02/2024	\$36.75	\$9.65	\$17.07	\$0.00	\$63.47
	06/02/2025	\$38.00	\$9.65	\$17.07	\$0.00	\$64.72
	12/01/2025	\$39.25	\$9.65	\$17.07	\$0.00	\$65.97
	06/01/2026	\$40.55	\$9.65	\$17.07	\$0.00	\$67.27
	12/07/2026	\$41.85	\$9.65	\$17.07	\$0.00	\$68.57
	06/07/2027	\$43.25	\$9.65	\$17.07	\$0.00	\$69.97
	12/06/2027	\$44.65	\$9.65	\$17.07	\$0.00	\$71.37
	06/05/2028	\$46.15	\$9.65	\$17.07	\$0.00	\$72.87
	12/04/2028	\$47.65	\$9.65	\$17.07	\$0.00	\$74.37

For apprentice rates see "Apprentice- LABORER"

POWDERMAN & BLASTER (HEAVY & HIGHWAY) <i>LABORERS - ZONE 3 (HEAVY & HIGHWAY)</i>	12/01/2024	\$36.75	\$9.65	\$15.06	\$0.00	\$61.46
	06/01/2025	\$38.00	\$9.65	\$15.06	\$0.00	\$62.71
	12/01/2025	\$39.24	\$9.65	\$15.06	\$0.00	\$63.95
	06/01/2026	\$40.54	\$9.65	\$15.06	\$0.00	\$65.25
	12/01/2026	\$41.83	\$9.65	\$15.06	\$0.00	\$66.54

For apprentice rates see "Apprentice- LABORER (Heavy and Highway)"

PUMP OPERATOR (CONCRETE) <i>OPERATING ENGINEERS LOCAL 98</i>	12/01/2023	\$39.56	\$13.78	\$15.15	\$0.00	\$68.49
---	------------	---------	---------	---------	--------	---------

For apprentice rates see "Apprentice- OPERATING ENGINEERS"

Classification	Effective Date	Base Wage	Health	Pension	Supplemental Unemployment	Total Rate
PUMP OPERATOR (DEWATERING, OTHER) <i>OPERATING ENGINEERS LOCAL 98</i>	12/01/2023	\$39.03	\$13.78	\$15.15	\$0.00	\$67.96
For apprentice rates see "Apprentice- OPERATING ENGINEERS"						
READY-MIX CONCRETE DRIVER <i>TEAMSTERS 404 - Construction Service (Northampton)</i>	05/01/2024	\$26.14	\$11.82	\$7.25	\$0.00	\$45.21
RIDE-ON MOTORIZED BUGGY OPERATOR <i>LABORERS - ZONE 3 (BUILDING & SITE)</i>	12/02/2024	\$36.00	\$9.65	\$17.07	\$0.00	\$62.72
	06/02/2025	\$37.25	\$9.65	\$17.07	\$0.00	\$63.97
	12/01/2025	\$38.50	\$9.65	\$17.07	\$0.00	\$65.22
	06/01/2026	\$39.80	\$9.65	\$17.07	\$0.00	\$66.52
	12/07/2026	\$41.10	\$9.65	\$17.07	\$0.00	\$67.82
	06/07/2027	\$42.50	\$9.65	\$17.07	\$0.00	\$69.22
	12/06/2027	\$43.90	\$9.65	\$17.07	\$0.00	\$70.62
	06/05/2028	\$45.40	\$9.65	\$17.07	\$0.00	\$72.12
	12/04/2028	\$46.90	\$9.65	\$17.07	\$0.00	\$73.62
For apprentice rates see "Apprentice- LABORER"						
ROLLER OPERATOR <i>OPERATING ENGINEERS LOCAL 98</i>	12/01/2023	\$38.42	\$13.78	\$15.15	\$0.00	\$67.35
For apprentice rates see "Apprentice- OPERATING ENGINEERS"						
ROOFER (Coal tar pitch) <i>ROOFERS LOCAL 248</i>	10/02/2024	\$42.38	\$10.35	\$18.00	\$0.00	\$70.73
	07/16/2025	\$43.88	\$10.35	\$18.00	\$0.00	\$72.23
	10/02/2025	\$44.88	\$10.35	\$18.00	\$0.00	\$73.23
	07/16/2026	\$46.88	\$10.35	\$18.00	\$0.00	\$75.23
For apprentice rates see "Apprentice- ROOFER"						
ROOFER (Inc.Roofer Waterproofing &Roofer Damproofg) <i>ROOFERS LOCAL 248</i>	10/02/2024	\$41.88	\$10.35	\$18.00	\$0.00	\$70.23
	07/16/2025	\$43.38	\$10.35	\$18.00	\$0.00	\$71.73
	10/02/2025	\$44.38	\$10.35	\$18.00	\$0.00	\$72.73
	07/16/2026	\$46.38	\$10.35	\$18.00	\$0.00	\$74.73

Apprentice - ROOFER - Local 248

Effective Date - 10/02/2024

Step	percent	Apprentice Base Wage	Health	Pension	Supplemental Unemployment	Total Rate
1	60	\$25.13	\$10.35	\$0.00	\$0.00	\$35.48
2	65	\$27.22	\$10.35	\$18.00	\$0.00	\$55.57
3	70	\$29.32	\$10.35	\$18.00	\$0.00	\$57.67
4	75	\$31.41	\$10.35	\$18.00	\$0.00	\$59.76
5	80	\$33.50	\$10.35	\$18.00	\$0.00	\$61.85
6	85	\$35.60	\$10.35	\$18.00	\$0.00	\$63.95
7	90	\$37.69	\$10.35	\$18.00	\$0.00	\$66.04
8	95	\$39.79	\$10.35	\$18.00	\$0.00	\$68.14

Notes:

Steps are 750 hrs.Roofer(Tear Off)1:1; Same as above

Apprentice to Journeyworker Ratio:1:3

Classification	Effective Date	Base Wage	Health	Pension	Supplemental Unemployment	Total Rate
ROOFER SLATE / TILE / PRECAST CONCRETE <i>ROOFERS LOCAL 248</i>	10/02/2024	\$42.38	\$10.35	\$18.00	\$0.00	\$70.73
	07/16/2025	\$43.88	\$10.35	\$18.00	\$0.00	\$72.23
	10/02/2025	\$44.88	\$10.35	\$18.00	\$0.00	\$73.23
	07/16/2026	\$46.88	\$10.35	\$18.00	\$0.00	\$75.23
For apprentice rates see "Apprentice- ROOFER"						
SCRAPER <i>OPERATING ENGINEERS LOCAL 98</i>	12/01/2023	\$39.03	\$13.78	\$15.15	\$0.00	\$67.96
For apprentice rates see "Apprentice- OPERATING ENGINEERS"						
SELF-POWERED ROLLERS AND COMPACTORS (TAMPERS) <i>OPERATING ENGINEERS LOCAL 98</i>	12/01/2023	\$38.42	\$13.78	\$15.15	\$0.00	\$67.35
For apprentice rates see "Apprentice- OPERATING ENGINEERS"						
SELF-PROPELLED POWER BROOM <i>OPERATING ENGINEERS LOCAL 98</i>	12/01/2023	\$35.80	\$13.78	\$15.15	\$0.00	\$64.73
For apprentice rates see "Apprentice- OPERATING ENGINEERS"						
SHEETMETAL WORKER <i>SHEETMETAL WORKERS LOCAL 63</i>	07/01/2024	\$40.98	\$12.20	\$18.74	\$2.13	\$74.05
	01/01/2025	\$42.23	\$12.20	\$18.74	\$2.13	\$75.30

Classification

Effective Date Base Wage Health Pension Supplemental Unemployment Total Rate

Apprentice - SHEET METAL WORKER - Local 63

Effective Date - 07/01/2024

Step	percent	Apprentice Base Wage	Health	Pension	Supplemental Unemployment	Total Rate
1	45	\$18.44	\$5.49	\$4.86	\$0.85	\$29.64
2	50	\$20.49	\$6.10	\$5.40	\$0.94	\$32.93
3	55	\$22.54	\$6.71	\$9.71	\$1.15	\$40.11
4	60	\$24.59	\$7.32	\$9.71	\$1.23	\$42.85
5	65	\$26.64	\$7.93	\$9.71	\$1.31	\$45.59
6	70	\$28.69	\$8.54	\$9.71	\$1.39	\$48.33
7	75	\$30.74	\$9.15	\$9.71	\$1.47	\$51.07
8	80	\$32.78	\$9.76	\$17.66	\$1.78	\$61.98
9	85	\$34.83	\$10.37	\$17.66	\$1.86	\$64.72
10	90	\$36.88	\$10.98	\$17.66	\$1.94	\$67.46

Effective Date - 01/01/2025

Step	percent	Apprentice Base Wage	Health	Pension	Supplemental Unemployment	Total Rate
1	45	\$19.00	\$5.49	\$4.86	\$0.85	\$30.20
2	50	\$21.12	\$6.10	\$5.40	\$0.94	\$33.56
3	55	\$23.23	\$6.71	\$9.71	\$1.15	\$40.80
4	60	\$25.34	\$7.32	\$9.71	\$1.23	\$43.60
5	65	\$27.45	\$7.93	\$9.71	\$1.31	\$46.40
6	70	\$29.56	\$8.54	\$9.71	\$1.39	\$49.20
7	75	\$31.67	\$9.15	\$9.71	\$1.47	\$52.00
8	80	\$33.78	\$9.76	\$17.66	\$1.78	\$62.98
9	85	\$35.90	\$10.37	\$17.66	\$1.86	\$65.79
10	90	\$38.01	\$10.98	\$17.66	\$1.94	\$68.59

Notes:

Apprentice to Journeyworker Ratio:1:3

SPECIALIZED EARTH MOVING EQUIP < 35 TONS TEAMSTERS JOINT COUNCIL NO. 10 ZONE B	12/01/2024	\$40.24	\$15.07	\$20.17	\$0.00	\$75.48
	01/01/2025	\$40.24	\$15.57	\$20.17	\$0.00	\$75.98
	06/01/2025	\$41.24	\$15.57	\$20.17	\$0.00	\$76.98
	12/01/2025	\$41.24	\$15.57	\$21.78	\$0.00	\$78.59
	01/01/2026	\$41.24	\$16.17	\$21.78	\$0.00	\$79.19
	06/01/2026	\$42.24	\$16.17	\$21.78	\$0.00	\$80.19
	12/01/2026	\$42.24	\$16.17	\$23.52	\$0.00	\$81.93
	01/01/2027	\$42.24	\$16.77	\$23.52	\$0.00	\$82.53

Classification	Effective Date	Base Wage	Health	Pension	Supplemental Unemployment	Total Rate
SPECIALIZED EARTH MOVING EQUIP > 35 TONS <i>TEAMSTERS JOINT COUNCIL NO. 10 ZONE B</i>	12/01/2024	\$40.53	\$15.07	\$20.17	\$0.00	\$75.77
	01/01/2025	\$40.53	\$15.57	\$20.17	\$0.00	\$76.27
	06/01/2025	\$41.53	\$15.57	\$20.17	\$0.00	\$77.27
	12/01/2025	\$41.53	\$15.57	\$21.78	\$0.00	\$78.88
	01/01/2026	\$41.53	\$16.17	\$21.78	\$0.00	\$79.48
	06/01/2026	\$42.53	\$16.17	\$21.78	\$0.00	\$80.48
	12/01/2026	\$42.53	\$16.17	\$23.52	\$0.00	\$82.22
	01/01/2027	\$42.53	\$16.77	\$23.52	\$0.00	\$82.82
SPRINKLER FITTER <i>SPRINKLER FITTERS LOCAL 669</i>	04/01/2023	\$47.43	\$11.45	\$16.61	\$0.00	\$75.49

Apprentice - *SPRINKLER FITTER - Local 669*

Effective Date - 04/01/2023

Step	percent	Apprentice Base Wage	Health	Pension	Supplemental Unemployment	Total Rate
1	45	\$21.34	\$8.22	\$0.00	\$0.00	\$29.56
2	50	\$23.72	\$8.22	\$0.00	\$0.00	\$31.94
3	55	\$26.09	\$11.45	\$7.20	\$0.00	\$44.74
4	60	\$28.46	\$11.45	\$8.35	\$0.00	\$48.26
5	65	\$30.83	\$11.45	\$8.35	\$0.00	\$50.63
6	70	\$33.20	\$11.45	\$8.60	\$0.00	\$53.25
7	75	\$35.57	\$11.45	\$8.60	\$0.00	\$55.62
8	80	\$37.94	\$11.45	\$8.60	\$0.00	\$57.99
9	85	\$40.32	\$11.45	\$8.60	\$0.00	\$60.37
10	90	\$42.69	\$11.45	\$8.60	\$0.00	\$62.74

Notes:

Apprentice to Journeyworker Ratio:1:1

TELECOMMUNICATION TECHNICIAN <i>ELECTRICIANS LOCAL 7</i>	06/30/2024	\$50.01	\$13.00	\$14.86	\$0.00	\$77.87
	12/29/2024	\$51.06	\$13.25	\$15.06	\$0.00	\$79.37
	06/29/2025	\$52.16	\$13.50	\$15.21	\$0.00	\$80.87
	12/28/2025	\$53.26	\$13.75	\$15.36	\$0.00	\$82.37
	06/28/2026	\$54.41	\$14.00	\$15.46	\$0.00	\$83.87
	01/03/2027	\$55.56	\$14.25	\$15.56	\$0.00	\$85.37

Classification	Effective Date	Base Wage	Health	Pension	Supplemental Unemployment	Total Rate
-----------------------	-----------------------	------------------	---------------	----------------	----------------------------------	-------------------

Apprentice - TERRAZZO MECH - Local 3 Marble/Tile (Spr/Pitt)

Effective Date - 08/01/2024

Step	percent	Apprentice Base Wage	Health	Pension	Supplemental Unemployment	Total Rate
1	50	\$32.26	\$11.49	\$23.56	\$0.00	\$67.31
2	60	\$38.71	\$11.49	\$23.56	\$0.00	\$73.76
3	70	\$45.16	\$11.49	\$23.56	\$0.00	\$80.21
4	80	\$51.62	\$11.49	\$23.56	\$0.00	\$86.67
5	90	\$58.07	\$11.49	\$23.56	\$0.00	\$93.12

Effective Date - 02/01/2025

Step	percent	Apprentice Base Wage	Health	Pension	Supplemental Unemployment	Total Rate
1	50	\$32.91	\$11.49	\$23.56	\$0.00	\$67.96
2	60	\$39.49	\$11.49	\$23.56	\$0.00	\$74.54
3	70	\$46.07	\$11.49	\$23.56	\$0.00	\$81.12
4	80	\$52.66	\$11.49	\$23.56	\$0.00	\$87.71
5	90	\$59.24	\$11.49	\$23.56	\$0.00	\$94.29

Notes:

Apprentice to Journeyworker Ratio:1:5

TEST BORING DRILLER <i>LABORERS - FOUNDATION AND MARINE</i>	12/01/2024	\$51.28	\$9.65	\$18.22	\$0.00	\$79.15
	06/01/2025	\$52.78	\$9.65	\$18.22	\$0.00	\$80.65
	12/01/2025	\$54.28	\$9.65	\$18.22	\$0.00	\$82.15
	06/01/2026	\$55.83	\$9.65	\$18.22	\$0.00	\$83.70
	12/01/2026	\$57.33	\$9.65	\$18.22	\$0.00	\$85.20

For apprentice rates see "Apprentice- LABORER"

TEST BORING DRILLER HELPER <i>LABORERS - FOUNDATION AND MARINE</i>	12/01/2024	\$47.07	\$9.65	\$18.22	\$0.00	\$74.94
	06/01/2025	\$48.57	\$9.65	\$18.22	\$0.00	\$76.44
	12/01/2025	\$50.07	\$9.65	\$18.22	\$0.00	\$77.94
	06/01/2026	\$51.62	\$9.65	\$18.22	\$0.00	\$79.49
	12/01/2026	\$53.12	\$9.65	\$18.22	\$0.00	\$80.99

For apprentice rates see "Apprentice- LABORER"

TEST BORING LABORER <i>LABORERS - FOUNDATION AND MARINE</i>	12/01/2024	\$46.95	\$9.65	\$18.22	\$0.00	\$74.82
	06/01/2025	\$48.45	\$9.65	\$18.22	\$0.00	\$76.32
	12/01/2025	\$49.95	\$9.65	\$18.22	\$0.00	\$77.82
	06/01/2026	\$51.50	\$9.65	\$18.22	\$0.00	\$79.37
	12/01/2026	\$53.00	\$9.65	\$18.22	\$0.00	\$80.87

For apprentice rates see "Apprentice- LABORER"

TRACTORS <i>OPERATING ENGINEERS LOCAL 98</i>	12/01/2023	\$38.42	\$13.78	\$15.15	\$0.00	\$67.35
--	------------	---------	---------	---------	--------	---------

For apprentice rates see "Apprentice- OPERATING ENGINEERS"

Classification	Effective Date	Base Wage	Health	Pension	Supplemental Unemployment	Total Rate
TRAILERS FOR EARTH MOVING EQUIPMENT <i>TEAMSTERS JOINT COUNCIL NO. 10 ZONE B</i>	12/01/2024	\$40.82	\$15.07	\$20.17	\$0.00	\$76.06
	01/01/2025	\$40.82	\$15.57	\$20.17	\$0.00	\$76.56
	06/01/2025	\$41.82	\$15.57	\$20.17	\$0.00	\$77.56
	12/01/2025	\$41.82	\$15.57	\$21.78	\$0.00	\$79.17
	01/01/2026	\$41.82	\$16.17	\$21.78	\$0.00	\$79.77
	06/01/2026	\$42.82	\$16.17	\$21.78	\$0.00	\$80.77
	12/01/2026	\$42.82	\$16.17	\$23.52	\$0.00	\$82.51
	01/01/2027	\$42.82	\$16.77	\$23.52	\$0.00	\$83.11
TUNNEL WORK - COMPRESSED AIR <i>LABORERS (COMPRESSED AIR)</i>	12/01/2024	\$59.18	\$9.65	\$19.00	\$0.00	\$87.83
	06/01/2025	\$60.68	\$9.65	\$19.00	\$0.00	\$89.33
	12/01/2025	\$62.18	\$9.65	\$19.00	\$0.00	\$90.83
	06/01/2026	\$63.73	\$9.65	\$19.00	\$0.00	\$92.38
	12/01/2026	\$65.23	\$9.65	\$19.00	\$0.00	\$93.88
For apprentice rates see "Apprentice- LABORER"						
TUNNEL WORK - COMPRESSED AIR (HAZ. WASTE) <i>LABORERS (COMPRESSED AIR)</i>	12/01/2024	\$61.18	\$9.65	\$19.00	\$0.00	\$89.83
	06/01/2025	\$62.68	\$9.65	\$19.00	\$0.00	\$91.33
	12/01/2025	\$64.18	\$9.65	\$19.00	\$0.00	\$92.83
	06/01/2026	\$65.73	\$9.65	\$19.00	\$0.00	\$94.38
	12/01/2026	\$67.23	\$9.65	\$19.00	\$0.00	\$95.88
For apprentice rates see "Apprentice- LABORER"						
TUNNEL WORK - FREE AIR <i>LABORERS (FREE AIR TUNNEL)</i>	12/01/2024	\$51.25	\$9.65	\$19.00	\$0.00	\$79.90
	06/01/2025	\$52.75	\$9.65	\$19.00	\$0.00	\$81.40
	12/01/2025	\$54.25	\$9.65	\$19.00	\$0.00	\$82.90
	06/01/2026	\$55.80	\$9.65	\$19.00	\$0.00	\$84.45
	12/01/2026	\$57.30	\$9.65	\$19.00	\$0.00	\$85.95
For apprentice rates see "Apprentice- LABORER"						
TUNNEL WORK - FREE AIR (HAZ. WASTE) <i>LABORERS (FREE AIR TUNNEL)</i>	12/01/2024	\$53.25	\$9.65	\$19.00	\$0.00	\$81.90
	06/01/2025	\$54.75	\$9.65	\$19.00	\$0.00	\$83.40
	12/01/2025	\$56.25	\$9.65	\$19.00	\$0.00	\$84.90
	06/01/2026	\$57.80	\$9.65	\$19.00	\$0.00	\$86.45
	12/01/2026	\$59.30	\$9.65	\$19.00	\$0.00	\$87.95
For apprentice rates see "Apprentice- LABORER"						
VAC-HAUL <i>TEAMSTERS JOINT COUNCIL NO. 10 ZONE B</i>	12/01/2024	\$40.24	\$15.07	\$20.17	\$0.00	\$75.48
	01/01/2025	\$40.24	\$15.57	\$20.17	\$0.00	\$75.98
	06/01/2025	\$41.24	\$15.57	\$20.17	\$0.00	\$76.98
	12/01/2025	\$41.24	\$15.57	\$21.78	\$0.00	\$78.59
	01/01/2026	\$41.24	\$16.17	\$21.78	\$0.00	\$79.19
	06/01/2026	\$42.24	\$16.17	\$21.78	\$0.00	\$80.19
	12/01/2026	\$42.24	\$16.17	\$23.52	\$0.00	\$81.93
	01/01/2027	\$42.24	\$16.77	\$23.52	\$0.00	\$82.53

Classification	Effective Date	Base Wage	Health	Pension	Supplemental Unemployment	Total Rate
WAGON DRILL OPERATOR <i>LABORERS - ZONE 3 (BUILDING & SITE)</i>	12/02/2024	\$36.00	\$9.65	\$17.07	\$0.00	\$62.72
	06/02/2025	\$37.25	\$9.65	\$17.07	\$0.00	\$63.97
	12/01/2025	\$38.50	\$9.65	\$17.07	\$0.00	\$65.22
	06/01/2026	\$39.80	\$9.65	\$17.07	\$0.00	\$66.52
	12/07/2026	\$41.10	\$9.65	\$17.07	\$0.00	\$67.82
	06/07/2027	\$42.50	\$9.65	\$17.07	\$0.00	\$69.22
	12/06/2027	\$43.90	\$9.65	\$17.07	\$0.00	\$70.62
	06/05/2028	\$45.40	\$9.65	\$17.07	\$0.00	\$72.12
	12/04/2028	\$46.90	\$9.65	\$17.07	\$0.00	\$73.62
For apprentice rates see "Apprentice- LABORER"						
WAGON DRILL OPERATOR (HEAVY & HIGHWAY) <i>LABORERS - ZONE 3 (HEAVY & HIGHWAY)</i>	12/01/2024	\$36.00	\$9.65	\$15.06	\$0.00	\$60.71
	06/01/2025	\$37.25	\$9.65	\$15.06	\$0.00	\$61.96
	12/01/2025	\$38.49	\$9.65	\$15.06	\$0.00	\$63.20
	06/01/2026	\$39.79	\$9.65	\$15.06	\$0.00	\$64.50
	12/01/2026	\$41.08	\$9.65	\$15.06	\$0.00	\$65.79
For apprentice rates see "Apprentice- LABORER (Heavy and Highway)"						
WATER METER INSTALLER <i>PLUMBERS & PIPEFITTERS LOCAL 104</i>	03/17/2024	\$49.21	\$9.55	\$17.10	\$0.00	\$75.86
For apprentice rates see "Apprentice- PLUMBER/PIPEFITTER" or "PLUMBER/GASFITTER"						
Marine Drilling						
BLASTER <i>MARINE DRILLING</i>	01/01/2018	\$41.82	\$7.63	\$3.60	\$0.00	\$53.05
BOAT CAPTAIN <i>MARINE DRILLING</i>	01/01/2018	\$33.87	\$7.63	\$3.30	\$0.00	\$44.80
BOAT CAPTAIN / Over 1,000 hp <i>MARINE DRILLING</i>	01/01/2018	\$38.06	\$7.63	\$3.60	\$0.00	\$49.29
CORE DRILLER <i>MARINE DRILLING</i>	01/01/2018	\$31.43	\$7.63	\$2.90	\$0.00	\$41.96
CORE DRILLER HELPER <i>MARINE DRILLING</i>	01/01/2018	\$28.47	\$7.63	\$3.00	\$0.00	\$39.10
DRILLER <i>MARINE DRILLING</i>	01/01/2018	\$39.70	\$7.63	\$3.60	\$0.00	\$50.93
ENGINEER <i>MARINE DRILLING</i>	01/01/2018	\$39.69	\$7.63	\$3.50	\$0.00	\$50.82
HELPER <i>MARINE DRILLING</i>	01/01/2018	\$34.24	\$7.63	\$3.00	\$0.00	\$44.87
MACHINIST <i>MARINE DRILLING</i>	01/01/2018	\$38.88	\$7.63	\$3.30	\$0.00	\$49.81
OILER - MARINE DRILLING <i>MARINE DRILLING</i>	01/01/2018	\$34.24	\$7.63	\$3.00	\$0.00	\$44.87
TUG DECKHAND <i>MARINE DRILLING</i>	01/01/2018	\$27.61	\$7.63	\$3.00	\$0.00	\$38.24
WELDER <i>MARINE DRILLING</i>	01/01/2018	\$38.88	\$7.63	\$3.30	\$0.00	\$49.81
Op Eng Marine (Dredging Work)						
BOAT OPERATOR <i>OPERATING ENGINEERS - MARINE DIVISION</i>	10/01/2017	\$29.26	\$7.63	\$3.30	\$0.00	\$40.19
CERTIFIED WELDER <i>OPERATING ENGINEERS - MARINE DIVISION</i>	10/01/2017	\$31.09	\$7.63	\$3.60	\$0.00	\$42.32

Classification	Effective Date	Base Wage	Health	Pension	Supplemental Unemployment	Total Rate
CHIEF WELDER/ CHIEF MATE <i>OPERATING ENGINEERS - MARINE DIVISION</i>	10/01/2017	\$33.02	\$7.63	\$3.60	\$0.00	\$44.25
DERRICK / SPIDER / SPILLBARGE OPERATOR <i>OPERATING ENGINEERS - MARINE DIVISION</i>	10/01/2017	\$33.02	\$7.63	\$3.60	\$0.00	\$44.25
DRAG BARGE OPERATOR / WELDER / MATE <i>OPERATING ENGINEERS - MARINE DIVISION</i>	10/01/2017	\$30.24	\$7.63	\$3.30	\$0.00	\$41.17
ENGINEER / ELECTRICIAN <i>OPERATING ENGINEERS - MARINE DIVISION</i>	10/01/2017	\$33.02	\$7.63	\$3.60	\$0.00	\$44.25
LICENSED BOAT OPERATOR <i>OPERATING ENGINEERS - MARINE DIVISION</i>	10/01/2017	\$33.02	\$7.63	\$3.60	\$0.00	\$44.25
LICENSED TUG OPERATOR OVER 1000HP <i>OPERATING ENGINEERS - MARINE DIVISION</i>	10/01/2017	\$38.18	\$7.63	\$3.60	\$0.00	\$49.41
MAINTENANCE ENGINEER <i>OPERATING ENGINEERS - MARINE DIVISION</i>	10/01/2017	\$33.03	\$7.63	\$3.60	\$0.00	\$44.26
OILER - MARINE DIVISION <i>OPERATING ENGINEERS - MARINE DIVISION</i>	10/01/2017	\$24.30	\$7.63	\$3.00	\$0.00	\$34.93
OPERATOR / LEVERMAN <i>OPERATING ENGINEERS - MARINE DIVISION</i>	10/01/2017	\$38.18	\$7.63	\$3.60	\$0.00	\$49.41
RODMAN / SCOWMAN <i>OPERATING ENGINEERS - MARINE DIVISION</i>	10/01/2017	\$24.30	\$7.63	\$3.00	\$0.00	\$34.93
SHOREMAN / DECKHAND <i>OPERATING ENGINEERS - MARINE DIVISION</i>	10/01/2017	\$24.30	\$7.63	\$3.00	\$0.00	\$34.93

Additional Apprentices Information:

All apprentices must be registered with the Division of Apprenticeship Training (DAS) in accordance with M.G.L. c. 23, §§ 11E-11L. Minimum wage rates for apprentices employed on public works projects are listed above as a percentage of the hourly prevailing wage rate established by the Commissioner under the provisions of M.G.L. c. 149, §§ 26-27D. Apprentice ratios are established by DAS pursuant to M.G.L. c. 23, §§ 11E-11L. Ratios are expressed as the allowable number of apprentices to journeymen or fraction thereof, unless otherwise specified. The ratios listed herein have been taken from relevant private collective bargaining agreements (CBAs) and are provided for illustrative purposes only. They have not been independently verified as being accurate or continuing to be accurate. Parties having questions regarding what ratio to use should contact DAS.

THIS PAGE IS INTENTIONALLY LEFT BLANK

DOCUMENT 00870

STANDARD FEDERAL EQUAL EMPLOYMENT OPPORTUNITY CONSTRUCTION CONTRACT
SPECIFICATIONS

(EXECUTIVE ORDER 11246)

Revised April 9, 2019

1. As used in these specifications:
 - a. "Covered area" means the geographical area described in the solicitation from which this contract resulted:
 - b. "Director" means Director, Office of Federal Contract Compliance Programs, United States Department of Labor, or any person to whom the Director delegates authority.
 - c. "Employer identification number" means the Federal Social Security number used on the Employer's Quarterly Federal Tax Return, U.S. Treasury Department Form 941.
 - d. "Minority" includes:
 - (i) Black (all persons having origins in any of the black African racial groups not of Hispanic origin);
 - (ii) Hispanic (all persons of Mexican, Puerto Rican, Cuban, Central or South American or other Spanish Culture or origin, regardless of race);
 - (iii) Asian and Pacific Islander (all persons having origins in any of the original peoples of the Far East, Southeast Asia, the Indian Subcontinent, or the Pacific Islands); and
 - (iv) American Indian or Alaskan Native (all persons having origins in any of the original peoples of North America and maintaining identifiable tribal affiliations through membership and participation or community identification).
2. Whenever the Contractor, or any Subcontractor at any tier, subcontracts a portion of the work involving any construction trade, it shall physically include in each subcontract in excess of \$ 10,000 the provisions of the specifications and the Notice which contains the applicable goals for minority and female participation and which is set forth in the solicitations from which this contract resulted.
3. If the Contractor is participating (pursuant to 41 CFR 60-4.5) in a Hometown Plan approved by the U.S. Department of Labor in the covered area either individually or through an association, its affirmative action obligations on all work in the Plan area (including goals and timetables) shall be in accordance with that Plan for those trades which have unions participating in the Plan. Contractors must be able to demonstrate their participation in and compliance with the provisions of any such Hometown Plan. Each Contractor or Subcontractor participating in an approved Plan is individually required to comply with its obligations under the EEO clause, and to make a good faith effort to achieve each goal under the plan in each trade in which it has employees. The overall good faith performance by other Contractors or Subcontractors toward a goal in an approved Plan does not excuse any covered Contractor's or Subcontractor's failure to take good faith efforts to achieve the Plan goals and timetables.
4. The Contractor shall implement the specific affirmative action standards provided in Paragraphs 7a through p of these specifications. The goals set forth in the solicitation from which this contract resulted are expressed as percentages of the total hours of employment and training of minority and female utilization the Contractor should reasonably be able to achieve in each construction trade in which it has employees in the covered area. The Contractor is expected to make substantially uniform progress toward its goals in each craft during the period specified.
5. Neither the provisions of any collective bargaining agreement, nor the failure by a union with whom the Contractor has a collective bargaining agreement, to refer either minorities or women shall excuse the Contractor's obligations under these specifications, Executive Order 11246, or the regulations promulgated pursuant thereto.

6. In order for the nonworking training hours of apprentices and trainees to be counted in meeting the goals, such apprentices and trainees must be employed by the Contractor during the training period, and the Contractor must have made a commitment to employ the apprentices and trainees at the completion of their training, subject to the availability of employment opportunities. Trainees must be trained pursuant to training programs approved by the U.S. Department of Labor.
7. The Contractor shall take specific affirmative actions to ensure equal employment opportunity. The evaluation of the Contractor's compliance with these specifications shall be based upon its effort to achieve maximum results from its actions. The Contractor shall document these efforts fully, and shall implement affirmative action steps at least as extensive as the following:
 - a. Ensure and maintain a working environment free of harassment, intimidation, and coercion at all sites, and all facilities at which the Contractor's employees are assigned to work. The Contractor, where possible, will assign two or more women to each construction project. The Contractor shall specifically ensure that all foremen, superintendents, and other on-site supervisory personnel are aware of and carry out the Contractor's obligation to maintain such a working environment, with specific attention to minority or female individuals working at such sites or in such facilities.
 - b. Establish and maintain a current list of minority and female recruitment sources, provide written notification to minority and female recruitment sources and to community organizations when the Contractor or its unions have employment opportunities available, and maintain a record of the organizations' responses.
 - c. Maintain a current file of the names, addresses and telephone numbers of each minority and female off-the-street applicant and minority or female referral from a union, a recruitment source or community organization and of what action was taken with respect to each such individual. If such individual was sent to the union hiring hall for referral and was not referred back to the Contractor by the union or, if referred, not employed by the Contractor, this shall be documented in the file with the reason therefor, along with whatever additional actions the Contractor may have taken.
 - d. Provide immediate written notification to the Director when the union or unions with which the Contractor has a collective bargaining agreement has not referred to the Contractor a minority person or woman sent by the Contractor, or when the Contractor has other information that the union referral process has impeded the Contractor's efforts to meet its obligations.
 - e. Develop on-the-job training opportunities and/or participate in training programs for the area which expressly include minorities and women, including upgrading programs and apprenticeship and trainee programs relevant to the Contractor's employment needs, especially those programs funded or approved by the Department of Labor. The Contractor shall provide notice of these programs to the sources compiled under 7b above.
 - f. Disseminate the Contractor's EEO policy by providing notice of the policy to unions and training programs and requesting their cooperation in assisting the Contractor in meeting its EEO obligations; by including it in any policy manual and collective bargaining agreement; by publicizing it in the company newspaper, annual report, etc; by specific review of the policy with all management personnel and with all minority and female employees at least once a year; and by posting the company EEO policy on bulletin boards accessible to all employees at each location where construction work is performed.
 - g. Review, at least annually, the company's EEO policy and affirmative action obligations under these specifications with all employees having any responsibility for hiring, assignment, layoff, termination or other employment decisions including specific review of these items with on-site supervisory personnel such as Superintendents, General Foremen, etc., prior to the initiation of construction work at any job site. A written record shall be made and maintained identifying the time and place of these meetings, persons attending, subject matter discussed, and disposition of the subject matter.
 - h. Disseminate the Contractor's EEO policy externally by including it in any advertising in the news media, specifically including minority and female news media, and providing written notification to and discussing the Contractor's EEO policy with other Contractors and Subcontractors with whom the Contractor does or anticipates doing business.

- i. Direct its recruitment efforts both oral and written, to minority, female and community organizations, to schools with minority and female students and to minority and female recruitment and training organizations serving the Contractor's recruitment area and employment needs. Not later than one month prior to the date for the acceptance of applications for apprenticeship or other training by any recruitment source, the Contractor shall send written notification to organizations such as the above, describing the openings, screening procedures, and tests to be used in the selection process.
 - j. Encourage present minority and female employees to recruit other minority persons and women and, where reasonable, provide after school, summer and vacation employment to minority and female youth both on the site and in other areas of a Contractor's work force.
 - k. Validate all tests and other selection requirements where there is an obligation to do so under 41 CFR Part 60-3.
 - l. Conduct, at least annually, an inventory and evaluation at least of all minority and female personnel for promotional opportunities and encourage these employees to seek or to prepare for, through appropriate training, etc., such opportunities.
 - m. Ensure that seniority practices, job classifications, work assignments and other personnel practices, do not have a discriminatory effect by continually monitoring all personnel and employment related activities to ensure that the EEO policy and the Contractor's obligations under these specifications are being carried out.
 - n. Ensure that all facilities and company activities are nonsegregated except that separate or single-user toilet and necessary changing facilities shall be provided to assure privacy between the sexes.
 - o. Document and maintain a record of all solicitations of offers for subcontracts from minority and female construction contractors and suppliers, including circulation of solicitations to minority and female contractor associations and other business associations.
 - p. Conduct a review, at least annually, of all supervisor's adherence to and performance under the Contractor's EEO policies and affirmative action obligations.
8. Contractors are encouraged to participate in voluntary associations which assist in fulfilling one or more of their affirmative action obligations (7a through p). The efforts of a contractor association, joint contractor-union, contractor-community, or other similar group of which the contractor is a member and participant, may be asserted as fulfilling any one or more of its obligations under 7a through p of these Specifications provided that the Contractor actively participates in the group, makes every effort to assure that the group has a positive impact on the employment of minorities and women in the industry, ensures that the concrete benefits of the program are reflected in the Contractor's minority and female work force participation, makes a good faith effort to meet its individual goals and timetables, and can provide access to documentation which demonstrates the effectiveness of actions taken on behalf of the Contractor. The obligation to comply, however, is the Contractor's and failure of such a group to fulfill an obligation shall not be a defense for the Contractor's noncompliance.
 9. A single goal for minorities and a separate single goal for women have been established. The Contractor, however, is required to provide equal employment opportunity and to take affirmative action for all minority groups, both male and female, and all women, both minority and non-minority. Consequently, the Contractor may be in violation of the Executive Order if a particular group is employed in a substantially disparate manner (for example, even though the Contractor has achieved its goals for women generally, the Contractor may be in violation of the Executive Order if a specific minority group of women is underutilized).
 10. The Contractor shall not use the goals and timetables of affirmative action standards to discriminate against any person because of race, color, religion, sex, or national origin.
 11. The Contractor shall not enter into any Subcontract with any person or firm debarred from Government contracts pursuant to Executive Order 11246.

12. The Contractor shall carry out such sanctions and penalties for violation of these specifications and of the Equal Opportunity Clause, including suspension, termination and cancellation of existing subcontracts as may be imposed or ordered pursuant to Executive Order 11246, as amended, and its implementing regulations, by the Office of Federal Contract Compliance programs. Any Contractor who fails to carry out such sanctions and penalties shall be in violation of these specifications and Executive Order 11246, as amended.
13. The Contractor, in fulfilling its obligations under these specifications, shall implement specific affirmative action steps, at least as extensive as those standards prescribed in paragraph 7 of these specifications so as to achieve maximum results from its efforts to ensure equal employment opportunity. If the Contractor fails to comply with the requirements of the Executive Order, the implementing regulations, or these specifications, the Director shall proceed in accordance with 41 CFR 60-4.8.
14. The Contractor shall designate a responsible official to monitor all employment related activity to ensure that the company EEO policy is being carried out, to submit reports relating to the provisions hereof as many be required by the Government and keep records. Records shall at least include for each employee the name, address, telephone numbers, construction trade, union affiliation if any, employee identification number when assigned, social security number, race, sex, status (e.g., mechanic, apprentice, trainee, helper, or laborer), dates of changes in status, hours worked per week in the indicated trade, rate of pay, and locations at which the work was performed. Records shall be maintained in an easily understandable and retrievable form; however, to the degree that existing records satisfy this requirement, contractors shall not be required to maintain separate records.
15. Nothing herein provided shall be construed as a limitation upon the application of other laws which establish different standards of compliance or upon the application of requirements for the hiring of local or other area residents (e.g., those under the Public Works Employment Act of 1977 and the Community Development Block Grant Program).

APPENDIX A

The following goals and timetables for female utilization shall be included in all Federal and federally assisted construction contracts and subcontracts in excess of \$ 10,000. The goals are applicable to the Contractor's aggregate on-site construction workforce whether or not part of that workforce is performing work on a Federal or federally-assisted construction contract or subcontract.

Area covered: Goal for Women apply nationwide

Goals and Timetables

Timetable

Goals (percent)

From Apr. 1, 1980 until further notice

6.9

APPENDIX B-80

Until further notice, the following goals for minority utilization in each construction craft and trade shall included in all Federal or federally assisted construction contracts and subcontracts in excess of \$ 10,000 to be performed in the respective geographical areas. The goals are applicable to each nonexempt contractor's total on- site construction workforce, regardless of whether or not part of that workforce is performing work on a Federal, federally assisted or nonfederally related project, contract or subcontract.

Construction contractors participating in an approved Hometown Plan (see 41 CFR 6-4.5) are required to comply with the goals of the Hometown Plan with regard to construction work they perform in the area covered by the Hometown Plan. With regard to all their other covered construction work, such contractors are required to comply with the applicable SMSA or EA goal contained in this Appendix B-80.

Economic Areas

<u>STATE:</u>	<u>Goals (percent)</u>
MASSACHUSETTS	
004 Boston MA:	
SMSA Counties:	
1123 Boston-Lowell-Brockton-Lawrence-Haverhill, MA-NH	4.0
MA Essex, MA Middlesex, MA Norfolk, MA Plymouth, MA Suffolk, NH Rockingham.	
5403 Fall River- New Bedford MA, Bristol	1.6
9243 Worcester-Fitchburg-Leominster, MA	1.6
6323 Springfield-Chicopee-Holyoke MA-CT	
MA Hampden, MA Hampshire	4.8
Non-SMSA Counties: MA Barnstable, MA Dukes, MA Nantucket	3.6
Non-SMSA Counties: MA Franklin	5.9

APPENDIX C

During the performance of this contract, the contractor, for itself, its assignees, and successors in interest (hereinafter referred to as the “contractor”) agrees as follows:

1. **Compliance with Regulations:** The contractor (hereinafter includes consultants) will comply with the Acts and Regulations relative to Non-discrimination in Federally-assisted programs of the U.S. Department of Transportation, Federal Highway Administration (FHWA), as they may be amended from time to time, which are herein incorporated by reference and made a part of this contract.
2. **Non-discrimination:** The contractor, with regard to the work performed by it during the contract, will not discriminate on the grounds of race, color, national origin (including limited English proficiency), age, sex, disability, or low-income status in the selection and retention of subcontractors, including procurements of materials and leases of equipment. The contractor will not participate directly or indirectly in the discrimination prohibited by the Acts and the Regulations, including employment practices when the contract covers any activity, project, or program set forth in Appendix B of 49 CFR Part 21.
3. **Solicitations for Subcontractors, including Procurements of Materials and Equipment:** In all solicitations, either by competitive bidding, or negotiation made by the contractor for work to be performed under a subcontract, including procurements of materials, or leases of equipment, each potential subcontractor or supplier will be notified by the contractor of the contractor’s obligations under this contract and the Acts and the Regulations relative to nondiscrimination on the grounds of race, color, national origin (including limited English proficiency), age, sex, disability, or low-income status.
4. **Information and Reports:** The contractor will provide all information and reports required by the Acts, the Regulations, and directives issued pursuant thereto, and will permit access to its books, records, accounts, other sources of information, and its facilities as may be determined by the Massachusetts Department of Transportation (MassDOT) or FHWA to be pertinent to ascertain compliance with such Acts, Regulations, and instructions. Where any information required of a contractor is in the exclusive possession of another who fails or refuses to furnish this information, the contractor will so certify to MassDOT or FHWA, as appropriate, and will set forth what efforts it has made to obtain the information.
5. **Sanctions for Noncompliance:** In the event of a contractor’s noncompliance with the Nondiscrimination provisions of this contract, MassDOT will impose such contract sanctions as it or FHWA may determine to be appropriate, including, but not limited to:
 - a. withholding payments to the contractor under the contract until the contractor complies; and/or
 - b. cancelling, terminating, or suspending a control, in whole or in part.
6. **Incorporation of Provisions:** The contractor will include the provisions of paragraphs one through six in every subcontract, including procurements of materials and leases of equipment, unless exempt by the Acts, the Regulations, and directives issued pursuant thereto. The contractor will take action with respect to any subcontract or procurement as MassDOT or FHWA may direct as a means of enforcing such provisions including sanctions for noncompliance. Provided, that if the contractor becomes involved in, or is threatened with litigation by a subcontractor, or supplier because of such direction, the contractor may request MassDOT to enter into any litigation to protect the interests of MassDOT. In addition, the contractor may request the United States to enter into the litigation to protect the interests of the United States.

APPENDIX D

During the performance of this contract, the contractor, for itself, its assignees, and successors in interest (hereinafter referred to as the “contractor,” which includes consultants) agrees to comply with the following non-discrimination statutes and authorities; including but not limited to:

PERTINENT NON-DISCRIMINATION AUTHORITIES:

- Title VI of the Civil Rights Act of 1964 (42 U.S.C. § 2000d *et seq.*, 78 stat. 252) (prohibits discrimination on the basis of race, color, national origin); and 49 CFR Part 21
- The Uniform Relocation Assistance and Real Property Acquisition Policies Act of 1970 (42 U.S.C. § 4601) (prohibits unfair treatment of persons displaced or whose property has been acquired because of Federal or Federal-Aid programs and projects)
- Federal-Aid Highway Act of 1973 (23 U.S.C. § 324 *et seq.*) (prohibits discrimination on the basis of sex)
- Section 504 of the Rehabilitation Act of 1973 (29 U.S.C. § 794 *et seq.*), as amended (prohibits discrimination on the basis of disability) and 49 CFR Part 27
- The Age Discrimination Act of 1975, as amended (42 U.S.C. § 6101 *et seq.*) (prohibits discrimination on the basis of age)
- Airport and Airway Improvement Act of 1982 (49 U.S.C. § 471, Section 47123), as amended (prohibits discrimination based on race, creed, color, national origin, or sex)
- The Civil Rights Restoration Act of 1987 (PL 100-209) (broadened the scope, coverage, and applicability of Title VI of the Civil Rights Act of 1964, the Age Discrimination Act of 1975, and Section 504 of the Rehabilitation Act of 1973, by expanding the definition of the terms “programs or activities” to include all of the programs or activities of Federal-Aid recipients, sub-recipients, and contractors, whether such programs or activities are Federally funded or not)
- Titles II and III of the Americans with Disabilities Act (42 U.S.C. §§ 12131-12189), as implemented by Department of Transportation regulations at 49 CFR parts 37 and 38 (prohibits discrimination on the basis of disability in the operation of public entities, public and private transportation systems, places of public accommodation, and certain testing entities)
- The Federal Aviation Administration’s Non-Discrimination Statute (49 U.S.C. § 47123) (prohibits discrimination on the basis of race, color, national origin, and sex)
- Executive Order 12898, Federal Actions to Address Environmental Justice in Minority Populations and Low-Income Populations (ensures discrimination against minority populations by discouraging programs, policies, and activities with disproportionately high and adverse human health or environmental effects on minority and low-income populations)
- Executive Order 13166, Improving Access to Services for People with Limited English Proficiency, and resulting agency guidance, national origin discrimination includes discrimination because of limited English proficiency (LEP). To ensure compliance with Title VI, you must take reasonable steps to ensure that LEP persons have meaningful access to your programs (70 Fed. Reg. at 74087 to 74100)
- Title IX of the Education Amendments Act of 1972, as amended (20 U.S.C. 1681 *et seq.*) (prohibits discrimination on the basis of sex in education programs or activities)

*** END OF DOCUMENT ***

DOCUMENT 00875
TRAINEE SPECIAL PROVISIONS
Revised October, 2016

THE REQUIRED NUMBER OF TRAINEES TO BE TRAINED UNDER THIS CONTRACT WILL BE **X**

The contractor shall provide on-the job training aimed at developing full journeyworkers in the type of trade of job classification involved.

In the event that a contractor subcontracts a portion of the contract work, the General Contractor shall determine how many, if any, of the trainees are to be trained by the subcontractor, provided, however, that the contractor shall retain the primary responsibility for meeting the training requirements imposed by this special provision. The contractor shall also insure that this training special provision is made applicable to such subcontract. Where feasible, 25 percent of apprentices or trainees in each occupation shall be in their first year of apprenticeship or training.

The number of trainees shall be distributed among the work classifications on the basis of the contractor's needs and the availability of journeyworkers in the various classifications within a reasonable area of recruitment. Prior to commencing construction, the contractor shall submit to the Massachusetts Department Of Transportation (MassDOT) for approval the number of trainees to be trained in each selected classification and training program to be used. Furthermore, the contractor shall specify the starting time for training in each of the classifications. The contractor will be credited for each trainee employed on the contract work who is currently enrolled or becomes enrolled in an approved program and will be reimbursed for such trainees as provided hereinafter.

Training and upgrading of minorities and women toward journeyworker status is a primary objective of the Training Special Provision. Accordingly, the contractor shall make every effort to enroll minority and women trainees (e.g., by conducting systematic and direct recruitment through public and private sources likely to yield minority and women trainees) to the extent that such persons are available within a reasonable area of recruitment. The contractor will be responsible for demonstrating the steps that have been taken in pursuance thereof, prior to a determination as to whether the contractor is in compliance with this Training Special Provision. This training commitment is not intended, and shall not be used, to discriminate against any applicant for training.

No employee shall be trained under this Special Provision in any classification in which he or she has successfully completed a training course leading to journeyworker status or in which he or she has been employed as a journeyworker. The contractor should satisfy this requirement by including appropriate questions in the employee application or by other suitable means. Regardless of the method used the contractor's records should document the finding in each case.

The minimum length and type of training for each classification will be as established in the training program selected by the contractor and approved by the Massachusetts Department Of Transportation and the Federal Highway Administration. The Massachusetts Department Of Transportation and the Federal Highway Administration shall approve a program if it is reasonably calculated to meet the equal employment opportunity obligations of the contractor and to qualify the average trainee for journeyworker status in the classification concerned by the end of the training period. Furthermore, apprenticeship programs registered with the U.S. Department of Labor, Bureau of Apprenticeship and Training, or with a State apprenticeship agency recognized by the Bureau and training programs approved but not necessarily sponsored by the U.S. Department of Labor, Manpower Administration, Bureau of Apprenticeship and Training shall also be considered acceptable provided it is being administered in a manner consistent with the equal employment obligations of Federal-aid highway construction contracts. Approval or acceptance of a training program shall be obtained from the State prior to commencing work on the classification covered by the program. It is the intention of these provisions that training is to be provided in the construction crafts rather than clerk-typist or secretarial-type positions. Training is permissible in lower level management positions such as office engineers, estimators, timekeepers, etc. where the training is oriented toward construction applications. Training in the laborer classification may be permitted provided that significant and meaningful training is provided and approved by the Federal Highway Administration division office. Some offsite training is permissible as long as the training is an integral part of an approved training program and does not comprise a significant part of the overall training.

Reimbursement

Under these Training Special Provisions, reimbursement will be as follows:

The Contractor will only be reimbursed 80 cents for each hour of on the job training as specified in the approved Training Program.

The Contractor is advised and encouraged that it may train additional persons in excess of the number specified and will be reimbursed as stated above. Reimbursement will be made even though the contractor receives additional training program funds from other sources, provided such other source does not specifically prohibit the contractor from receiving other reimbursement.

If less than full training specified in the approved training programs is provided, payment to the contractor will be made at a rate of 80 cents for each hour of training completed under this contract. However, no payment shall be made to the contractor if either the failure to provide the required training, or the failure to hire the trainee as a journeyworker, is caused by the contractor and evidences a lack of good faith on the part of the contractor in meeting the requirements of this Training Special Provision.

Payment

Trainees will be paid:

1. Percentage (%) of the journeyworker's rate as provided in the existing programs approved by the Department of Labor or Transportation as of September 15, 1970.
2. For journeyworker programs submitted by the Contractor and approved by Massachusetts Department Of Transportation and the Federal Highway Administration at least 60 percent of the appropriate minimum journeyworker's rate specified in the contract for the first half of the training period, 75 percent for the third quarter if the training period, and 90 percent for the last quarter of the training period.
3. For skilled laborer programs, the minimum starting wage rate of unskilled laborer. At the conclusion of training, he or she will be paid the minimum wage rate of the Classification for programs submitted by the Contractor and approved by the Massachusetts Department Of Transportation and the Federal Highway Administration.
4. For the purposes of meeting the legal requirements of State Prevailing Wage Law, please be advised that no person may be paid the Apprentice wage rate as listed on a MA Prevailing Wage Rates schedule, unless that person and program is registered with the Department of Labor Standards/Division of Apprentice Standards (DLS/DAS). Any person or program not registered with DLS/DAS, regardless of whether or not they are registered with any other federal, state, local, or private entity must be paid the journeyworker's rate for the trade.

The contractor shall provide each trainee with a certification showing the type and length of training satisfactorily complete.

The contractor will provide for the maintenance of records and furnish periodic reports documenting his performance under this Training Special Provision.

Form FHWA-1409, Federal-aid Highway Construction Contracting Semi Annual Training Report, shall be submitted as per instructions on the Form.

*** END OF DOCUMENT ***

DOCUMENT 00880

Revised January 12, 2022



DEPARTMENT OF LABOR

Employment Standards Administration

MINIMUM WAGES FOR FEDERAL AND FEDERALLY ASSISTED CONTRACTS

THIS PAGE INTENTIONALLY LEFT BLANK

Modification Number	Publication Date
0	01/05/2024
1	01/19/2024
2	05/31/2024
3	06/21/2024
4	09/06/2024
5	09/13/2024
6	12/13/2024

* ENGI0004-019 12/01/2024

	Rates	Fringes
POWER EQUIPMENT OPERATOR		
Group 1.....	\$ 57.03	33.20
Group 2.....	\$ 56.40	33.20

FOOTNOTE FOR POWER EQUIPMENT OPERATORS:

A. PAID HOLIDAYS: New Year's Day, Washington's Birthday,
 Labor Day, Memorial Day, Independence Day, Patriot's Day,
 Columbus Day, Veteran's Day, Thanksgiving Day, Christmas Day

POWER EQUIPMENT OPERATORS CLASSIFICATIONS

Group 1: Broom/Sweeper; Crane; Gradall; Post Driver
 (Guardrail/Fences)
 Group 2: Bulldozer; Grader/Blade

 ENGI0098-010 06/01/2024

	Rates	Fringes
POWER EQUIPMENT OPERATOR		
Group 1.....	\$ 41.23	30.58+A
Group 2.....	\$ 40.92	30.58+A
Group 4.....	\$ 37.47	30.58+A

Footnote:

A. Paid Holidays: New year's Day, Washington's Birthday, Memorial Day, Independence Day, Labor Day, Columbus Day, Veterans Day, Thanksgiving Day and Christmas Day

POWER EQUIPMENT OPERATORS CLASSIFICATIONS

Group 1: Backhoe/Excavator/Trackhoe; Bobcat/Skid Steer/Skid Loader; Loader

Group 2: Milling Machine; Paver (Asphalt, Aggregate, and Concrete)

Group 4: Roller

IRON0007-027 03/16/2024

	Rates	Fringes
IRONWORKER (ORNAMENTAL AND STRUCTURAL)	\$ 39.51	32.98

LABO0596-006 12/01/2021

	Rates	Fringes
LABORER (Traffic Control: Flagger)	\$ 24.50	23.96

LABO0999-002 12/01/2021

	Rates	Fringes
LABORER (Common or General)	\$ 32.50	23.96

PAIN0035-023 07/01/2024

	Rates	Fringes
PAINTER (Steel)	\$ 56.76	36.00

SUMA2014-009 01/11/2017

	Rates	Fringes
CARPENTER, Includes Form Work.....	\$ 33.03	20.02
CEMENT MASON/CONCRETE FINISHER....	\$ 52.13	20.89
ELECTRICIAN.....	\$ 47.13	13.41
IRONWORKER, REINFORCING.....	\$ 46.21	21.27
LABORER: Asphalt, Includes Raker, Shoveler, Spreader and Distributor.....	\$ 33.10	18.09
LABORER: Concrete Saw (Hand Held/Walk Behind).....	\$ 44.43	14.18
LABORER: Landscape.....	\$ 44.11	18.85
OPERATOR: Forklift.....	\$ 51.63	0.00
OPERATOR: Mechanic.....	\$ 48.14	17.02
OPERATOR: Piledriver.....	\$ 43.87	18.04
PAINTER: Spray (Linestriping)....	\$ 38.30	17.43
TRAFFIC CONTROL: Laborer-Cones/ Barricades/Barrels - Setter/Mover/Sweeper.....	\$ 43.73	15.06
TRUCK DRIVER: Concrete Truck....	\$ 33.69	15.79
TRUCK DRIVER: Dump Truck.....	\$ 43.81	5.39
TRUCK DRIVER: Flatbed Truck.....	\$ 48.53	0.00

WELDERS - Receive rate prescribed for craft performing operation to which welding is incidental.

=====
=====

Note: Executive Order (EO) 13706, Establishing Paid Sick Leave for Federal Contractors applies to all contracts subject to the Davis-Bacon Act for which the contract is awarded (and any solicitation was issued) on or after January 1, 2017. If this contract is covered by the EO, the contractor must provide employees with 1 hour of paid sick leave for every 30 hours they work, up to 56 hours of paid sick leave each year. Employees must be permitted to use paid sick leave for their own illness, injury or other health-related needs, including preventive care; to assist a family member (or person who is like family to the employee) who is ill, injured, or has other health-related needs, including preventive care; or for reasons resulting from, or to assist a family member (or person who is like family to the employee) who is a victim of, domestic violence, sexual assault, or stalking. Additional information on contractor requirements and worker protections under the EO is available at <https://www.dol.gov/agencies/whd/government-contracts>.

Unlisted classifications needed for work not included within the scope of the classifications listed may be added after award only as provided in the labor standards contract clauses (29CFR 5.5 (a) (1) (iii)).

The body of each wage determination lists the classifications and wage rates that have been found to be prevailing for the type(s) of construction and geographic area covered by the wage determination. The classifications are listed in alphabetical order under rate identifiers indicating whether the particular rate is a union rate (current union negotiated rate), a survey rate, a weighted union average rate, a state adopted rate, or a supplemental classification rate.

Union Rate Identifiers

A four-letter identifier beginning with characters other than "SU", "UAVG", ?SA?, or ?SC? denotes that a union rate was prevailing for that classification in the survey. Example: PLUM0198-005 07/01/2024. PLUM is an identifier of the union whose collectively bargained rate prevailed in the survey for this classification, which in this example would be Plumbers. 0198 indicates the local union number or district council number where applicable, i.e., Plumbers Local 0198. The next number, 005 in the example, is an internal number used in processing the wage determination. The date, 07/01/2024 in the example, is the effective date of the most current negotiated rate.

Union prevailing wage rates are updated to reflect all changes over time that are reported to WHD in the rates in the collective bargaining agreement (CBA) governing the classification.

Union Average Rate Identifiers

The UAVG identifier indicates that no single rate prevailed for those classifications, but that 100% of the data reported for the classifications reflected union rates. EXAMPLE:

UAVG-OH-0010 01/01/2024. UAVG indicates that the rate is a weighted union average rate. OH indicates the State of Ohio.

The next number, 0010 in the example, is an internal number used in producing the wage determination. The date, 01/01/2024

in the example, indicates the date the wage determination was updated to reflect the most current union average rate.

A UAVG rate will be updated once a year, usually in January, to reflect a weighted average of the current rates in the collective bargaining agreements on which the rate is based.

Survey Rate Identifiers

The ""SU"" identifier indicates that either a single non-union rate prevailed (as defined in 29 CFR 1.2) for this classification in the survey or that the rate was derived by

computing a weighted average rate based on all the rates reported in the survey for that classification. As a weighted

average rate includes all rates reported in the survey, it may

include both union and non-union rates. Example: SUFL2022-007

6/27/2024. SU indicates the rate is a single non-union prevailing rate or a weighted average of survey data for that classification. FL indicates the State of Florida. 2022 is the year of the survey on which these classifications and rates are based. The next number, 007 in the example, is an internal number used in producing the wage determination. The date, 6/27/2024 in the example, indicates the survey completion date for the classifications and rates under that identifier.

?SU? wage rates typically remain in effect until a new survey is conducted. However, the Wage and Hour Division (WHD) has the discretion to update such rates under 29 CFR 1.6(c)(1).

State Adopted Rate Identifiers

The ""SA"" identifier indicates that the classifications and prevailing wage rates set by a state (or local) government were adopted under 29 C.F.R 1.3(g)-(h). Example: SAME2023-007 01/03/2024. SA reflects that the rates are state adopted. ME refers to the State of Maine. 2023 is the year during which the state completed the survey on which the listed classifications and rates are based. The next number, 007 in the example, is an internal number used in producing the wage determination. The date, 01/03/2024 in the example, reflects the date on which the classifications and rates under the ?SA? identifier took effect under state law in the state from which the rates were

adopted.

WAGE DETERMINATION APPEALS PROCESS

1) Has there been an initial decision in the matter? This can be:

- a) a survey underlying a wage determination
- b) an existing published wage determination
- c) an initial WHD letter setting forth a position on a wage determination matter
- d) an initial conformance (additional classification and rate) determination

On survey related matters, initial contact, including requests for summaries of surveys, should be directed to the WHD Branch of Wage Surveys. Requests can be submitted via email to davisbaconinfo@dol.gov or by mail to:

Branch of Wage Surveys
Wage and Hour Division
U.S. Department of Labor
200 Constitution Avenue, N.W.
Washington, DC 20210

Regarding any other wage determination matter such as conformance decisions, requests for initial decisions should be directed to the WHD Branch of Construction Wage Determinations. Requests can be submitted via email to BCWD-Office@dol.gov or by mail to:

Branch of Construction Wage Determinations
Wage and Hour Division
U.S. Department of Labor
200 Constitution Avenue, N.W.
Washington, DC 20210

2) If an initial decision has been issued, then any interested party (those affected by the action) that disagrees with the decision can request review and reconsideration from the Wage and Hour Administrator (See 29 CFR Part 1.8 and 29 CFR Part 7). Requests for review and reconsideration can be submitted via email to dba.reconsideration@dol.gov or by mail to:

Wage and Hour Administrator
 U.S. Department of Labor
 200 Constitution Avenue, N.W.
 Washington, DC 20210

The request should be accompanied by a full statement of the interested party's position and any information (wage payment data, project description, area practice material, etc.) that the requestor considers relevant to the issue.

3) If the decision of the Administrator is not favorable, an interested party may appeal directly to the Administrative Review Board (formerly the Wage Appeals Board). Write to:

Administrative Review Board
 U.S. Department of Labor
 200 Constitution Avenue, N.W.
 Washington, DC 20210.

=====
 =====

END OF GENERAL DECISION"

"General Decision Number: MA20240010 12/13/2024

Superseded General Decision Number: MA20230010

State: Massachusetts

Construction Types: Heavy (Heavy and Marine)

Counties: Berkshire, Franklin, Hampden and Hampshire
Counties
in Massachusetts.

HEAVY CONSTRUCTION PROJECTS; AND MARINE CONSTRUCTION
PROJECTS

Note: Contracts subject to the Davis-Bacon Act are generally required to pay at least the applicable minimum wage rate required under Executive Order 14026 or Executive Order 13658.

Please note that these Executive Orders apply to covered contracts entered into by the federal government that are subject to the Davis-Bacon Act itself, but do not apply to contracts subject only to the Davis-Bacon Related Acts, including those set forth at 29 CFR 5.1(a)(1).

If the contract is entered	. Executive Order 14026
into on or after January 30,	generally applies to the
2022, or the contract is	contract.
renewed or extended (e.g., an	. The contractor must pay
option is exercised) on or	all covered workers at
after January 30, 2022:	least \$17.20 per hour (or
	the applicable wage rate
	listed on this wage

Additional information on contractor requirements and worker protections under the Executive Orders is available at <http://www.dol.gov/whd/govcontracts>.

Modification Number	Publication Date
0	01/05/2024
1	01/19/2024
2	02/09/2024
3	03/01/2024
4	03/22/2024
5	05/31/2024
6	07/05/2024
7	09/06/2024
8	09/13/2024
9	09/20/2024
10	10/11/2024
11	11/01/2024
12	12/13/2024

BOIL0029-001 01/01/2021

	Rates	Fringes
BOILERMAKER.....	\$ 45.87	29.02

BRMA0001-005 08/01/2023

SPRINGFIELD CHAPTER

	Rates	Fringes
BRICKLAYER		
BRICKLAYERS; CEMENT		
MASONS; PLASTERERS; STONE		
MASONS; MARBLE, TILE &		
TERRAZZO WORKERS.....	\$ 50.81	32.27

BRMA0001-007 08/01/2023

SPRINGFIELD/PITTSFIELD CHAPTER
BERKSHIRE COUNTY

	Rates	Fringes
BRICKLAYER		
BRICKLAYERS; CEMENT		
MASONS; PLASTERERS; STONE		
MASONS; MARBLE, TILE &		
TERRAZZO WORKERS.....	\$ 50.81	32.27

 CARP0056-004 08/01/2024

	Rates	Fringes
DIVER TENDER.....	\$ 61.70	35.47
DIVER.....	\$ 78.11	35.47

 CARP0056-009 08/01/2024

	Rates	Fringes
PILEDRIVERMAN.....	\$ 51.97	35.47

 CARP0336-005 09/01/2024

FRANKLIN COUNTY (Erving, Orange, North Orange, and Warwick)

	Rates	Fringes
CARPENTER.....	\$ 41.90	27.40

 CARP0336-010 09/01/2024

BERKSHIRE

Rates	Fringes
-------	---------

CARPENTER.....\$ 41.90 27.40

CARP0336-012 09/01/2024

HAMPDEN; HAMPSHIRE; AND FRANKLIN (Remainder of County)

Rates Fringes

CARPENTER.....\$ 41.90 27.40

CARP1121-004 01/01/2024

Rates Fringes

MILLWRIGHT.....\$ 41.20 32.99

ELEC0007-002 06/30/2024

HAMPDEN (Except Chester & Holyoke); HAMPSHIRE (Belchertown, Ware)

Rates Fringes

ELECTRICIAN.....\$ 50.01 27.71

ELEC0007-003 06/30/2024

BERKSHIRE; FRANKLIN; HAMPDEN (Chester, Holyoke); HAMPSHIRE (Except Belchertown, Ware)

Rates Fringes

ELECTRICIAN.....\$ 50.01 27.71

ENGI0098-007 06/01/2024

Rates Fringes

Power equipment operators:

Group 1.....	\$ 41.23	30.58+A
Group 2.....	\$ 40.92	30.58+A
Group 3.....	\$ 40.70	30.58+A
Group 4.....	\$ 37.47	30.58+A
Group 5.....	\$ 36.35	30.58+A
Group 6.....	\$ 34.41	30.58+A
Group 7.....	\$ 52.73	30.58+A
Group 8.....	\$ 42.41	30.58+A
Group 9.....	\$ 42.72	30.58+A
Group 10.....	\$ 44.73	30.58+A
Group 11.....	\$ 45.73	30.58+A
Group 12.....	\$ 47.23	30.58+A
Group 13.....	\$ 48.23	30.58+A
Group 14.....	\$ 49.23	30.58+A
Group 15.....	\$ 50.73	30.58+A

HAZARDOUS WASTE PREMIUM \$2.00

FOOTNOTE FOR POWER EQUIPMENT OPERATORS:

Group 8 and Group 9 are per day wages.

A. Paid Holidays: New year's Day, Washington's Birthday, Memorial Day, Independence Day, Labor Day, Columbus Day, Veterans Day, Thanksgiving Day and Christmas Day

POWER EQUIPMENT OPERATORS CLASSIFICATIONS

Group 1: Shovels; crawlers and truck cranes including all tower; self-propelled hydraulic cranes 10 tons and over; draglines; clam shells; cableways; shaft hoists; mucking machines derricks; backhoes; bulldozers; gradalls; elevating graders; pile drivers; concrete pavers; trenching machines; front end loaders- 5 1/2 cu yds and over; dual drum paver; automatic grader-excavator(C.M.I. or equal); scrapers towing pan or wagon; tandem dozers or push cats(2 units in tandem); shotcrete machine; tunnel boring machine; combination backhoe/loader 3/4 cu yd hoe or over; jet engine dryer; tree shredder; post hole digger; post hole hammer; post extractor; truck mounted concrete pump with boom; roto-mill; Grader; Horizontal Drilling Machine;

John

Henry Rock Drill and similar equipment.

Group 2: Rotary drill with mounted compressor;
compressor

house (3 to 6 compressors); rock and earth boring
machines

(excluding McCarthy and similar drills); front end
loaders

4 cu yds to 5 1/2 cu yds); forklifts-7 ft lift and over 3
ton capacity; scraper 21 yds and over (struck load);

sonic

hammer console; reclaimers road planer/milling machine;
cal

tracks; ballast regulators; rail anchor machines; switch
tampers, asphalt pavers; mechanic; welder and transfer
machine.

Group 3: Combination backhoe/loader up to 3/4 cu yd;
scrapers up to 21 cu yd (struck load, self propelled or
tractor drawn); tireman; front end loaders up to 4 yds;
well drillers; engineer or fireman on high pressure
boiler;

self-loading batch plant; well point operators electric
pumps used in well point system; pumps, 16 inches and
over

(total discharge); compressor, one or two 900 cu ft and
over; powered grease truck; tunnel locomotives and
dingys;

grout pumps; hydraulic jacks; boom truck; hydraulic
cranes-

up to 10 ton.

Group 4: Asphalt rollers; self-powered rollers and
compactors; tractor without blade drawing sheepsfoot
roller; rubber tire roller; vibratory roller or other
type

of compactors including machines for pulverizing and
aerating soil; york rake.

Group 5: Hoists; conveyors; power pavement breakers;
self-powered concrete pavement finishing machines; two
bag

mixers with skip; McCarthy and similar drills; batch
plants

(not self loading); bulk cement plants; self-propelled
material spreaders; three or more 10 KW light plants; 30
KW or more generators; power broom.

Group 6: Compressor (one or two) 315 cu ft to 900 cu ft;
pumps 4 inches to 16 inches (total discharge).

Group 7: Compressors up to 315 cu ft; small mixers with skip; pumps up to 4 inches; power heaters; oiler; A-frame trucks; forklifts-up to 7 ft. lift and up to 3 ton capacity; hydro broom; stud welder.

Group 8: Truck crane crews

Group 9: Oiler

Group 10: Master Mechanic

Group 11: Boom lengths over 150 feet including jib

Group 12: Boom lengths over 200 feet including jib

Group 13: Boom lengths over 250 feet including jib

Group 14: Boom lengths over 300 feet including jib

Group 15: Boom lengths over 350 feet including jib

IRON0007-014 03/16/2024

BERKSHIRE (Becket, East Otis, Hinsdale, Monterey, New Marlboro, North Otis, Otis, Peru, Sandisfield, Savoy, Sheffield, Washington, Windsor); FRANKLIN; HAMPDEN; HAMPSHIRE

	Rates	Fringes
IRONWORKER.....	\$ 39.51	32.98

IRON0012-003 07/01/2024

BERKSHIRE (Lee)

	Rates	Fringes
IRONWORKER.....	\$ 38.50	28.46

IRON0012-004 07/01/2024

BERKSHIRE (Remainder of County)

	Rates	Fringes
--	-------	---------

Ironworkers:

Sheeter.....	\$ 38.75	28.46
Structural, Ornamental, Reinforcing, Fence Erector, Machinery Mover, Rigger, Rodman, Stone Derrickman.....	\$ 38.50	28.46

* LABO0022-002 12/01/2024

FRANKLIN (Orange, Warwick)

	Rates	Fringes
Laborers:		
GROUP 1.....	\$ 38.95	29.41
GROUP 2.....	\$ 39.20	29.41
GROUP 3.....	\$ 39.70	29.41
GROUP 4.....	\$ 39.95	29.41
GROUP 5.....	\$ 39.70	29.41
GROUP 6.....	\$ 40.95	29.41

LABORERS CLASSIFICATIONS

GROUP 1: Laborers; carpenter tenders; cement finisher tenders, plasterer tenders

GROUP 2: Asphalt raker; fence and guard rail erector; laser beam operator; mason tender; pipelayer; pneumatic drill operator; pneumatic tool operator; wagon drill operator; jackhammer operator, pavement breaker, carbide core drilling machine, chain saw operator, barco type jumping tampers, concrete pump, motorized mortar miner, ride-on motorized buggy

GROUP 3: Air track operator; block paver; rammer; curb setter, hydraulic and similar self-powered drills

GROUP 4: Blaster; powderman

GROUP 5: Precast floor and roof, plank erector

GROUP 6: Asbestos Abatement, Toxic and Hazardous waste laborers

LAB00473-005 12/01/2021

FRANKLIN (Except Orange and Warrick); HAMPDEN and HAMPSHIRE COUNTIES (with the exception of Chesterfield, Cummington, Goshen, Middlefield, Plainfield, and Worthington)

	Rates	Fringes
Laborers:		
Group 1.....	\$ 30.37	24.64
Group 2.....	\$ 30.62	24.64
Group 3.....	\$ 31.12	24.64
Group 4.....	\$ 31.37	24.64
Group 5.....	\$ 24.50	24.64
Group 6.....	\$ 32.37	24.64

LABORERS CLASSIFICATIONS

Group 1: Carpenter tenders, cement finisher tenders, laborers, wrecking laborers

Group 2: Asphalt rakers, fence and guard rail erectors, laser beam operator, mason tender, pipelayer, pneumatic drill operator, pneumatic tool operator, wagon drill operator

Group 3: Air track operator, block pavers, rammers, curb setters

Group 4: Blasters, powdermen

Group 5: Flaggers

Group 6: Asbestos abatement, toxic and Hazardous waste laborers

LABO0473-006 12/01/2021

BERKSHIRE; HAMPSHIRE COUNTIES (the towns of Chesterfield, Cummington, Goshen, Middlefield, Plainfield, and Worthington only)

	Rates	Fringes
Laborers:		
Group 1.....	\$ 30.37	24.49
Group 2.....	\$ 30.62	24.49
Group 3.....	\$ 31.12	24.49
Group 4.....	\$ 31.37	24.49
Group 5.....	\$ 24.50	24.49
Group 6.....	\$ 32.37	24.49

LABORERS CLASSIFICATIONS

Group 1: Carpenter tenders, cement finisher tenders, laborers, wrecking laborers

Group 2: Asphalt rakers, fence and guard rail erectors, laser beam operator, mason tender, pipelayer, pneumatic drill operator, pneumatic tool operator, wagon drill operator

Group 3: Air track operator, block pavers, rammers, curb setters

Group 4: Blasters, powdermen

Group 5: Flaggers

Group 6: Asbestos abatement, toxic and Hazardous waste laborers

LABO1421-002 12/01/2021

	Rates	Fringes
Laborers:		
Group 1.....	\$ 41.33	27.37
Group 2.....	\$ 42.08	27.35
Group 3.....	\$ 42.33	27.35
Group 4.....	\$ 37.33	27.35
Group 5.....	\$ 40.43	27.35
Group 6.....	\$ 41.33	27.37

Group 1: Adzeman, Wrecking Laborer.
 Group 2: Burners, Jackhammers.
 Group 3: Small Backhoes, Loaders on tracks, Bobcat Type Loaders, Hydraulic ""Brock"" Type Hammer Operators, Concrete Cutting Saws.
 Group 4: Yardman (Salvage Yard Only).
 Group 5: Yardman, Burners, Sawyers.
 Group 6: Asbestos, Lead Paint, Toxic and Hazardous Waste.

PAIN0035-010 07/01/2024

	Rates	Fringes
PAINTER		
NEW CONSTRUCTION:		
Brush, Taper.....	\$ 38.78	31.85
Spray, Sandblast.....	\$ 39.48	31.85
REPAINT:		
Bridge.....	\$ 56.76	31.85
Brush, Taper.....	\$ 35.40	31.85
Spray, Sandblast.....	\$ 36.80	31.85

PLUM0004-003 09/01/2024

FRANKLIN (Orange)

	Rates	Fringes
Plumber and Steamfitter.....	\$ 55.00	28.77

PLUM0104-004 09/17/2024

BERKSHIRE (Becket, Otis, Sandisfield); FRANKLIN (Except Monroe, Rowe, and the Western part of Charlemont); HAMPDEN; HAMPSHIRE

	Rates	Fringes
Plumbers and Pipefitters.....	\$ 49.26	29.35

FOOTNOTE:

A. Two paid holidays, Independence Day and Labor Day, provided the employee has been employed seven days prior to the holiday by the same employer

PLUM0104-009 09/17/2024

BERKSHIRE (Except Otis, Becket, Sandisfield); FRANKLIN (Monroe, Rowe and the Western part of Charlemont)

	Rates	Fringes
Plumber and Steamfitter.....	\$ 49.26	29.35

FOOTNOTE FOR PLUMBERS & STEAMFITTERS:

A. Paid holidays: Independence Day and Labor Day, provided the employee has been employed seven days prior to the holiday by the same employer.

TEAM0379-001 06/01/2024

	Rates	Fringes
Truck drivers:		
Group 1.....	\$ 39.78	35.24+a+b
Group 2.....	\$ 39.95	35.24+a+b
Group 3.....	\$ 40.02	35.24+a+b
Group 4.....	\$ 40.14	35.24+a+b
Group 5.....	\$ 40.24	35.24+a+b
Group 6.....	\$ 40.53	35.24+a+b
Group 7.....	\$ 40.82	35.24+a+b

POWER TRUCKS \$.25 DIFFERENTIAL BY AXLE
TUNNEL WORK (UNDERGROUND ONLY) \$.40 DIFFERENTIAL BY AXLE
HAZARDOUS MATERIALS (IN HOT ZONE ONLY) \$2.00 PREMIUM

TRUCK DRIVERS CLASSIFICATIONS

Group 1: Station wagons; panel trucks; and pickup trucks

Group 2: Two axle equipment; & forklift operator

Group 3: Three axle equipment and tireman

Group 4: Four and Five Axle equipment

Group 5: Specialized earth moving equipment under 35 tons

other than conventional type trucks; low bed; vachual; mechanics, paving restoration equipment

Group 6: Specialized earth moving equipment over 35 tons

Group 7: Trailers for earth moving equipment (double hookup)

FOOTNOTES:

A. PAID HOLIDAYS: New Year's Day, Washington's Birthday, Memorial Day, Independence Day, Labor Day, Patriot's Day, Columbus Day, Veteran's Day, Thanksgiving Day and Christmas Day

B. PAID VACATION: Employees with 4 months to 1 year of service receive 1/2 day's pay per month; 1 week vacation for 1 - 5 years of service; 2 weeks vacation for 5 - 10 years of service; and 3 weeks vacation for more than 10 years of service

WELDERS - Receive rate prescribed for craft performing operation to which welding is incidental.

=====
=====

Note: Executive Order (EO) 13706, Establishing Paid Sick Leave for Federal Contractors applies to all contracts subject to the Davis-Bacon Act for which the contract is awarded (and any solicitation was issued) on or after January 1, 2017. If this contract is covered by the EO, the contractor must provide employees with 1 hour of paid sick leave for every 30 hours they work, up to 56 hours of paid sick leave each year. Employees must be permitted to use paid sick leave for their own illness, injury or other health-related needs, including preventive care; to assist a family member (or person who is like family to the employee) who is ill, injured, or has other

health-related needs, including preventive care; or for reasons resulting from, or to assist a family member (or person who is like family to the employee) who is a victim of, domestic violence, sexual assault, or stalking. Additional information on contractor requirements and worker protections under the EO is available at <https://www.dol.gov/agencies/whd/government-contracts>.

Unlisted classifications needed for work not included within the scope of the classifications listed may be added after award only as provided in the labor standards contract clauses (29CFR 5.5 (a) (1) (iii)).

The body of each wage determination lists the classifications and wage rates that have been found to be prevailing for the type(s) of construction and geographic area covered by the wage determination. The classifications are listed in alphabetical order under rate identifiers indicating whether the particular rate is a union rate (current union negotiated rate), a survey rate, a weighted union average rate, a state adopted rate, or a supplemental classification rate.

Union Rate Identifiers

A four-letter identifier beginning with characters other than "SU", "UAVG", ?SA?, or ?SC? denotes that a union rate was prevailing for that classification in the survey. Example: PLUM0198-005 07/01/2024. PLUM is an identifier of the union whose collectively bargained rate prevailed in the survey for this classification, which in this example would be Plumbers. 0198 indicates the local union number or district council number where applicable, i.e., Plumbers Local 0198. The next number, 005 in the example, is an internal number used in processing the wage determination. The date, 07/01/2024 in the example, is the effective date of the most current negotiated rate.

Union prevailing wage rates are updated to reflect all changes over time that are reported to WHD in the rates in the collective bargaining agreement (CBA) governing the classification.

Union Average Rate Identifiers

The UAVG identifier indicates that no single rate prevailed for those classifications, but that 100% of the data reported for the classifications reflected union rates. EXAMPLE: UAVG-OH-0010 01/01/2024. UAVG indicates that the rate is a weighted union average rate. OH indicates the State of Ohio. The next number, 0010 in the example, is an internal number used in producing the wage determination. The date, 01/01/2024 in the example, indicates the date the wage determination was updated to reflect the most current union average rate.

A UAVG rate will be updated once a year, usually in January, to reflect a weighted average of the current rates in the collective bargaining agreements on which the rate is based.

Survey Rate Identifiers

The "SU" identifier indicates that either a single non-union rate prevailed (as defined in 29 CFR 1.2) for this classification in the survey or that the rate was derived by computing a weighted average rate based on all the rates reported in the survey for that classification. As a weighted average rate includes all rates reported in the survey, it may include both union and non-union rates. Example: SUFL2022-007 6/27/2024. SU indicates the rate is a single non-union prevailing rate or a weighted average of survey data for that classification. FL indicates the State of Florida. 2022 is the year of the survey on which these classifications and rates are based. The next number, 007 in the example, is an internal number used in producing the wage determination. The date, 6/27/2024 in the example, indicates the survey completion date for the classifications and rates under that identifier.

?SU? wage rates typically remain in effect until a new survey is conducted. However, the Wage and Hour Division (WHD) has the discretion to update such rates under 29 CFR 1.6(c)(1).

State Adopted Rate Identifiers

The "SA" identifier indicates that the classifications and prevailing wage rates set by a state (or local) government were adopted under 29 C.F.R 1.3(g)-(h). Example: SAME2023-007 01/03/2024. SA reflects that the rates are state adopted. ME refers to the State of Maine. 2023 is the year during which the state completed the survey on which the listed classifications and rates are based. The next number, 007 in the example, is an internal number used in producing the wage determination. The date, 01/03/2024 in the example, reflects the date on which the classifications and rates under the "SA" identifier took effect under state law in the state from which the rates were adopted.

WAGE DETERMINATION APPEALS PROCESS

1) Has there been an initial decision in the matter? This can be:

- a) a survey underlying a wage determination
- b) an existing published wage determination
- c) an initial WHD letter setting forth a position on a wage determination matter
- d) an initial conformance (additional classification and rate) determination

On survey related matters, initial contact, including requests for summaries of surveys, should be directed to the WHD Branch of Wage Surveys. Requests can be submitted via email to davisbaconinfo@dol.gov or by mail to:

Branch of Wage Surveys
Wage and Hour Division
U.S. Department of Labor
200 Constitution Avenue, N.W.
Washington, DC 20210

Regarding any other wage determination matter such as conformance decisions, requests for initial decisions should be directed to the WHD Branch of Construction Wage Determinations. Requests can be submitted via email to BCWD-Office@dol.gov or by mail to:

Branch of Construction Wage Determinations
Wage and Hour Division
U.S. Department of Labor
200 Constitution Avenue, N.W.
Washington, DC 20210

2) If an initial decision has been issued, then any interested party (those affected by the action) that disagrees with the decision can request review and reconsideration from the Wage and Hour Administrator (See 29 CFR Part 1.8 and 29 CFR Part 7). Requests for review and reconsideration can be submitted via email to dba.reconsideration@dol.gov or by mail to:

Wage and Hour Administrator
U.S. Department of Labor
200 Constitution Avenue, N.W.
Washington, DC 20210

The request should be accompanied by a full statement of the interested party's position and any information (wage payment data, project description, area practice material, etc.) that the requestor considers relevant to the issue.

3) If the decision of the Administrator is not favorable, an interested party may appeal directly to the Administrative Review Board (formerly the Wage Appeals Board). Write to:

Administrative Review Board
U.S. Department of Labor
200 Constitution Avenue, N.W.
Washington, DC 20210.

=====
=====

END OF GENERAL DECISION"

"General Decision Number: MA20240006 01/05/2024

Superseded General Decision Number: MA20230006

State: Massachusetts

Construction Type: Heavy Dredging

Counties: Massachusetts Statewide.
STATEWIDE

Massachusetts All Dredging, except self-propelled hopper dredges, on the Atlantic Coast & tributary waters emptying into the Atlantic Ocean.

Note: Contracts subject to the Davis-Bacon Act are generally required to pay at least the applicable minimum wage rate required under Executive Order 14026 or Executive Order 13658.

Please note that these Executive Orders apply to covered contracts entered into by the federal government that are subject to the Davis-Bacon Act itself, but do not apply to contracts subject only to the Davis-Bacon Related Acts, including those set forth at 29 CFR 5.1(a)(1).

If the contract is entered	. Executive Order 14026
into on or after January 30,	generally applies to the
2022, or the contract is	contract.
renewed or extended (e.g., an	. The contractor must pay
option is exercised) on or	all covered workers at
after January 30, 2022:	least \$17.20 per hour (or
	the applicable wage rate
	listed on this wage

INCENTIVE PAY: (Add to Hourly Rate)

Operator (NCCCO License/Certification) \$1.80 Licensed
 Tug
 Operator over 1000 HP (Assigned as Master) (USCG
 licensed
 Master of Towing Vessels (MOTV) \$1.80; Licensed Boat
 Operator (Assigned as lead boat captain) USCG licensed
 boat operator \$1.30; Engineer (QMED and Tankerman
 endorsement or licensed engineer (USCG) \$1.80
 Oiler (QMED and Tankerman endorsement (USCG) \$1.80; All
 classifications (Tankerman endorsement only) USCG \$1.55;
 Deckhand or Mate (AB with Lifeboatman endorsement (USCG)
 \$1.80; All classifications (lifeboatman endorsement only
 (USCG) \$1.55; Welder (ABS certification) \$1.55

FOOTNOTES APPLICABLE TO ABOVE CRAFTS:

- a. PAID HOLIDAYS: New Year's Day, Martin Luther King,
 Jr.'s
 Birthday, Memorial Day, Good Friday, Independence Day,
 Labor Day, Veterans' Day, Thanksgiving Day and Christmas
 Day
- b. VACATION: Eight percent (8%) of the straight time
 rate,
 multiplied by the total hours worked.

WELDERS - Receive rate prescribed for craft performing operation to which welding is incidental.

=====
 =====

Note: Executive Order (EO) 13706, Establishing Paid Sick
 Leave
 for Federal Contractors applies to all contracts subject to
 the
 Davis-Bacon Act for which the contract is awarded (and any
 solicitation was issued) on or after January 1, 2017. If
 this

contract is covered by the EO, the contractor must provide employees with 1 hour of paid sick leave for every 30 hours they work, up to 56 hours of paid sick leave each year. Employees must be permitted to use paid sick leave for their own illness, injury or other health-related needs, including preventive care; to assist a family member (or person who is like family to the employee) who is ill, injured, or has other health-related needs, including preventive care; or for reasons resulting from, or to assist a family member (or person who is like family to the employee) who is a victim of, domestic violence, sexual assault, or stalking. Additional information on contractor requirements and worker protections under the EO is available at <https://www.dol.gov/agencies/whd/government-contracts>.

Unlisted classifications needed for work not included within the scope of the classifications listed may be added after award only as provided in the labor standards contract clauses (29CFR 5.5 (a) (1) (iii)).

The body of each wage determination lists the classification and wage rates that have been found to be prevailing for the cited type(s) of construction in the area covered by the wage determination. The classifications are listed in alphabetical

order of ""identifiers"" that indicate whether the particular rate is a union rate (current union negotiated rate for local), a survey rate (weighted average rate) or a union average rate (weighted union average rate).

Union Rate Identifiers

A four letter classification abbreviation identifier enclosed in dotted lines beginning with characters other than ""SU"" or ""UAVG"" denotes that the union classification and rate were prevailing for that classification in the survey. Example: PLUM0198-005 07/01/2014. PLUM is an abbreviation identifier of the union which prevailed in the survey for this classification, which in this example would be Plumbers. 0198 indicates the local union number or district council number where applicable, i.e., Plumbers Local 0198. The next number, 005 in the example, is an internal number used in processing the wage determination. 07/01/2014 is the effective date of the most current negotiated rate, which in this example is July 1, 2014.

Union prevailing wage rates are updated to reflect all rate changes in the collective bargaining agreement (CBA) governing this classification and rate.

Survey Rate Identifiers

Classifications listed under the ""SU"" identifier indicate that

no one rate prevailed for this classification in the survey and the published rate is derived by computing a weighted average rate based on all the rates reported in the survey for that classification. As this weighted average rate includes all rates reported in the survey, it may include both union and non-union rates. Example: SULA2012-007 5/13/2014. SU indicates the rates are survey rates based on a weighted average calculation of rates and are not majority rates. LA indicates the State of Louisiana. 2012 is the year of survey on which these classifications and rates are based. The next number, 007 in the example, is an internal number used in producing the wage determination. 5/13/2014 indicates the survey completion date for the classifications and rates under that identifier.

Survey wage rates are not updated and remain in effect until a new survey is conducted.

Union Average Rate Identifiers

Classification(s) listed under the UAVG identifier indicate that no single majority rate prevailed for those classifications; however, 100% of the data reported for the classifications was union data. EXAMPLE: UAVG-OH-0010 08/29/2014. UAVG indicates that the rate is a weighted union average rate. OH indicates the state. The next number, 0010 in the example, is an internal number used in producing the wage determination. 08/29/2014 indicates the survey completion date for the classifications and rates under that identifier.

A UAVG rate will be updated once a year, usually in January of

each year, to reflect a weighted average of the current negotiated/CBA rate of the union locals from which the rate is based.

WAGE DETERMINATION APPEALS PROCESS

1.) Has there been an initial decision in the matter? This can be:

- * an existing published wage determination
- * a survey underlying a wage determination
- * a Wage and Hour Division letter setting forth a position on a wage determination matter
- * a conformance (additional classification and rate) ruling

On survey related matters, initial contact, including requests for summaries of surveys, should be with the Wage and Hour National Office because National Office has responsibility for the Davis-Bacon survey program. If the response from this initial contact is not satisfactory, then the process described in 2.) and 3.) should be followed.

With regard to any other matter not yet ripe for the formal process described here, initial contact should be with the Branch of Construction Wage Determinations. Write to:

Branch of Construction Wage Determinations
Wage and Hour Division
U.S. Department of Labor
200 Constitution Avenue, N.W.
Washington, DC 20210

2.) If the answer to the question in 1.) is yes, then an interested party (those affected by the action) can request review and reconsideration from the Wage and Hour Administrator

(See 29 CFR Part 1.8 and 29 CFR Part 7). Write to:

Wage and Hour Administrator
U.S. Department of Labor
200 Constitution Avenue, N.W.
Washington, DC 20210

The request should be accompanied by a full statement of the interested party's position and by any information (wage payment data, project description, area practice material, etc.) that the requestor considers relevant to the issue.

3.) If the decision of the Administrator is not favorable, an interested party may appeal directly to the Administrative Review Board (formerly the Wage Appeals Board). Write to:

Administrative Review Board
U.S. Department of Labor
200 Constitution Avenue, N.W.
Washington, DC 20210

4.) All decisions by the Administrative Review Board are final.

=====
=====

END OF GENERAL DECISION"

THIS PAGE INTENTIONALLY LEFT BLANK

DOCUMENT A00801

SPECIAL PROVISIONS**WEST SPRINGFIELD- CHICOPEE**
Federal Aid Project No. NHP(IM)/HIP(BR)-0912(310)X
Pavement and Bridge Preservation on I-91

Labor participation goals for this Project shall be 15.3% for minorities and 6.9% for women for each job category. The goals are applicable to both Contractor's and Subcontractor's on-site construction workforce. Refer to Document 00820 for details.

SCOPE OF WORK

All work under this Contract shall be done in conformance with the *2024 Standard Specifications for Highways and Bridges*, the *Supplemental Specifications* contained in this book, the *2017 Construction Standard Details*, the *Traffic Management Plans and Detail Drawings*, *MassDOT Work Zone Safety Temporary Traffic Control*, the *1990 Standard Drawings for Signs and Supports*; the *2015 Overhead Signal Structure and Foundation Standard Drawings*, the *2009 Manual on Uniform Traffic Control Devices (MUTCD) with Revisions 1, 2, and 3 and the November 2022 Massachusetts Amendments to the MUTCD*; the *1968 Standard Drawings for Traffic Signals and Highway Lighting*; *The American Standard for Nursery Stock*; the Plans and these Special Provisions.

The work to be completed under this contract consists of roadway fine milling and pavement resurfacing on Interstate 91 mainline and ramps at interchanges 10A and 10B in the cities of Chicopee and West Springfield. The project begins in Chicopee at mile 8.518 and extends northerly into West Springfield ending at mile 10.504. The length of the project is 1.98 miles.

The work includes chipping and patching bridge decks, bridge joint replacement, bridge deck resurfacing, installation of HMA berm, installation of new paved waterway, clearing roadway side slopes, removal of build-up material on shoulders to restore country drainage, adjusting and/or rebuilding drainage structures, repairing guardrail, installing recessed pavement markings and slotted pavement markers, implementing temporary traffic controls, installing erosion and sedimentation control measures, and other incidental items as set forth in the proposal and required to complete the work.

All proposed work is within the State Highway Layout. No rights to enter on, or occupy, private properties have been acquired for this project.

SUBSECTION 7.05 INSURANCE REQUIREMENTS

B. Public Liability Insurance

The insurance requirements set forth in this subsection are in addition to the requirements of the Standard Specifications and supersede all other requirements.

Paragraphs 1 and 2

The Massachusetts Department of Transportation and applicable railroads shall be named as additional insureds.

CONTRACTOR QUESTIONS AND ADDENDUM ACKNOWLEDGEMENTS

Prospective bidders are required to submit all questions to the Construction Contracts Engineer by 3:00 P.M. on the Tuesday of the previous week before the scheduled bid opening date. Any questions received after this time will not be considered for review by the Department.

Contractors should email questions and addendum acknowledgements to the following email address massdotSpecifications@dot.state.ma.us The MassDOT project file number and municipality is to be placed in the subject line.

ENVIRONMENTAL PERMITTING

Negative Determinations have been obtained from the West Springfield and Chicopee Conservation Commissions. If field conditions and/or Contractor-proposed erection, demolition, storage, or other procedures not originally allowed by existing environmental permits require work to occur in or otherwise impact water or wetland resource areas, the Contractor is advised that no associated work can occur until all required environmental permits have been either amended or obtained allowing such work. The Contractor must notify the District 2 Highway Director and Resident Engineer in writing at least 60 days prior to desired commencement of the proposed activity. All environmental submittals, including any contact with Local, State, or Federal environmental agencies, must be coordinated with the District 2 Environmental Engineer. The Contractor is expected to fully cooperate with requests for information and provide same in a timely manner. The Contractor is further advised that the Department will not entertain a delay claim due to the time required to modify or obtain the environmental permits.

CONTAMINATED SOIL

Soil to be removed from the project area shall not be assumed to be uncontaminated and must be evaluated prior to off-site management for potential contamination with hazardous materials. No soil may be disposed of off-site without proper assessment by the contractor and approval from the Resident Engineer (RE), District Environmental Engineer (DEE), or the project designee.

Three known Massachusetts Contingency Plan (MCP) hazardous materials release sites are located within the project area:

- RTN 1-14860, Rte. 91, 0.5 Miles North of Exit 13B, West Springfield
- RTN 1-19890, Interstate 91, Mile Marker 9.6 NB, West Springfield
- RTN 1-16955, I-91 North Chicopee Curve, I-91 North Center St Overpass, Chicopee

The construction contractor shall determine where excavation will be necessary and whether any excavation will take place within the boundaries of these release sites. Any excavation within the boundaries of the release sites must be performed in accordance with all relevant laws and regulations and as described in the required Environmental Health and Safety Plan.

SOIL STOCKPILING DIRECTIVE P-22-001

Any stockpiling of soil must be performed in compliance with Policy Directive P-22-001, Off-Site Stockpiling of Soil from MassDOT Construction Projects. This directive limits the allowable locations for off-site stockpiling of soil generated during MassDOT projects and includes various requirements that must be satisfied by the contractor prior to off-site stockpiling.

SUBSECTION 8.01 SUBLETTING OR ASSIGNMENT OF CONTRACT

Delete 1st paragraph of Subsection 8.01 and replace with:

“The Contractor shall not sublet, sell, transfer, assign, or otherwise dispose of the Contract or any portion thereof, or of their right, title, or interest therein, without written consent of the Engineer. In case such consent is given, the contractor will be permitted to sublet a portion thereof, but shall perform with their own organization, work amounting to not less than 30% of the original total Contract price, except that any items designated in the Contract as “specialty items” may be performed by Subcontract and the cost of any such specialty items so performed by Subcontract and the cost of any such specialty items so performed by Subcontracts may be deducted from the total cost computing the amount of work required to be performed by the Contractor with their own organization. No Subcontractors, or transfer of Contract, shall in any case release the Contractor of their liability under the Contract and Bonds.”

All other provisions in Subsection 8.01 apply.

WORK SCHEDULE (Supplementing Subsection 8.02)

All work that requires a lane closure shall be done at night on a 10-hour night, 4-night week, Monday evening through Friday morning between 7:00 PM and 5:30 AM.

Work activities that require only a shoulder closure may, at the discretion of the Engineer, be done on an 8-hour day, 5-day week, Monday through Friday. This work shall be scheduled during the day between the hours of 7:00 AM and 3:30 PM.

Temporary traffic control setups shall not begin prior to the start time of the specified work schedule. All work activities requiring a lane closure shall be completed by the end time of the specified work schedule (5:30 AM), including back rolling, removing all construction crew, equipment, and material from the roadway, and removing all temporary traffic control setups.

Traffic management coordination:

It is assumed that the work under this contract will be performed concurrently with the adjacent I-91 resurfacing project (Contract 124913). When applicable, the contractor shall coordinate his temporary traffic control activities with the adjacent project to extend or supplement their temporary traffic control. Should a conflict in the temporary traffic control plan arise, Contract 124913 shall have priority.

It is assumed that work under this contract will be performed concurrently with the adjacent bridge preservation project (Project 613219). When applicable, the contractor shall coordinate their temporary traffic control activities with the adjacent project. The contractor shall coordinate their construction sequencing with the adjacent project to avoid any interference.

DRAINAGE

It shall be the Contractor's responsibility to maintain drainage functioning properly in the areas under construction prior to the time when the final system is put into use.

Final adjustment to finished grade shall be made before the top course is laid. Any debris caused by the Contractor's construction deposited in drainage structures shall be removed at no cost to the Department.

All of the above work shall be included under the relevant drainage item without additional compensation.

NOTICE TO OWNERS OF UTILITIES

Written notice shall be given by the Contractor to all public service corporations or officials owning or having charge of publicly or privately owned utilities of his/her intention to commence operations affecting such utilities at least one week in advance of the commencement of such operations and the Contractor shall at that time file a copy of such notice with the Engineer.

A list of public and private utilities can be found on the MassDOT website at:
<https://www.mass.gov/info-details/utility-contacts-by-district-and-municipality>

Select District 2 on the webpage,
Select the City, and then locate the utility.

The utility contact list is for guidance only and is not guaranteed to be complete or up to date. Town officials are shown at website <https://www.mass.gov/lists/massachusetts-cities-and-towns> and select the required City/Town website.

State Police are shown at website <https://www.mass.gov/info-details/massachusetts-state-police-troop-boundaries>. Select the area of jurisdiction to find the local station.

The Contractor shall be responsible for informing the following officials in each area that he is assigned to work in:

Superintendent, Department of Public Works or Town Engineer.
Superintendent, Water Department. Superintendent, Sewer Departments.
Police Department, Fire Department, Electric Company, Railroads.

District 2 Utility/Constructability Engineer

Paul Kelly 857-368-2066
Paul.Kelly@dot.state.ma.us

Regional Transit Authority

Pioneer Valley Transit Authority (PVTA)
Sandra Sheehan 413-732-6248 Ex. 216
ssheehan@pvta.com
Paul Burns-Johnson 413-732-6248 Ex. 2230
pburns@pvta.com

EVERSOURCE EMERGENCY TELEPHONE NUMBERS

GAS:

Outage/ Emergency: 800-592-2000

New Service: 866-678-2744

Customer Support: 800-592-2000

ELECTRIC:

Outage/ Emergency: 800-592-2000 or 844-726-7562

New Service: 1-888-633-3797 (1-888-need pwr)

Customer Support: 1-800-340-9822

EXISTING INTELLIGENT TRANSPORTATION SYSTEMS

The contractor shall exercise caution while performing work near existing intelligent transportation systems (ITS). The following systems are present within project limits:

- MM 9.2: CCTV foundation located on southbound outside shoulder
- MM 10.1: CCTV foundation located in median
- MM 10.2: VMS located over northbound travel lanes

GUARDRAIL END TREATMENTS

Upon completion of the installation, the Contractor shall email GPS Coordinates of all newly installed End Treatments to Eric (Jay) Ehle (Eric.Ehle@dot.state.ma.us) & Ken Crochiere (Kenneth.Crochiere@dot.state.ma.us). The payment for this work will be included in the contract unit bid prices under end treatment items and no specific compensation will be made.

PAVEMENT MARKINGS & RUMBLE STRIPS

The Engineer will not provide a line of reference for establishing the pavement markings. It shall be the responsibility of the Contractor to reference and record all existing pavement markings, their locations and dimensions for reproduction after final paving. **The recording shall be done prior to any other work on the project and copies given to the Engineer.**

The Contractor is reminded to reference the relevant provisions of Traffic Standard Drawing TR.6.3 “Typical Pavement Markings for Freeways”.

All permanent pavement markings must be applied within two (2) weeks of paving the top course. All rumble strips must be installed within four (4) weeks of paving the top course. Upon completing the paving of the top course within any section of roadway the permanent pavement markings and rumble strips must be installed, the Contractor shall not wait until all of the paving has been completed.

Payment for this work will be included in the contract unit bid prices under the permanent pavement marking items on the project and no specific compensation will be made.

PRE-CONSTRUCTION CONFERENCE

Following the Notice to Proceed, a conference will be held at the Department's District Two office, 811 North King Street, Northampton, MA, on a date to be announced. At that time the Contractor will be required to submit a proposed schedule of operations in writing to the Engineer for review and approval.

NORTHERN LONG-EARED BAT AND TRICOLORED BAT PROTECTION

The U.S. Fish and Wildlife Service (USFWS) has listed the northern long-eared bat (*Myotis septentrionalis*; NLEB) and tricolored bat (*Perimyotis subflavus*; TCB) as federally endangered or proposed endangered, respectfully, under the Endangered Species Act (ESA). USFWS has developed this guidance to address ESA compliance and promote conservation of NLEB and TCB. This project has been consulted with the USFWS through the Federal Highway Administration (FHWA), Federal Railroad Administration (FRA), and Federal Transit Administration (FTA) Programmatic Biological Opinion for Transportation Projects in the Range of the Indiana Bat and Northern Long-Eared Bat revised February 5, 2018 and amended March 31, 2023.

On behalf of FHWA, the lead federal agency for Section 7 consultation, MassDOT submitted a FHWA, FRA, FTA Programmatic Consultation for Transportation Projects affecting NLEB or Indiana Bat to the USFWS through the Information for Planning and Consultation (IPaC) webpage. Therefore, the project has completed Section 7 consultation through the ESA.

In advance of the uplisting of the TCB to endangered under the ESA, the following Avoidance and Minimization Measures (AMMs) must be strictly adhered to in order to protect NLEB and TCB and to be in compliance with the ESA. Contact MassDOT Environmental Services - Wildlife Unit Supervisor (David Paulson, david.j.paulson@dot.state.ma.us, 857-262-3378) for questions about project limits, restrictions, or conservation measures.

General AMM

- The Contractor shall ensure all personnel working in on the project site are aware of all environmental commitments related to NLEB and TCB, including all applicable AMMs. NLEB and TCB information (<https://www.fws.gov/midwest/endangered/mammals/nleb/> and <https://www.fws.gov/species/tricolored-bat-perimyotis-subflavus>) shall be made available to all personnel.

Lighting AMMs

- Direct temporary lighting away from suitable habitat during the active season: **April 1 to October 31.**
- When installing new or replacing existing permanent lights, use downward-facing, full cut-off lens lights (with same intensity or less for replacement lighting); or for those transportation agencies using the BUG system developed by the Illuminating Engineering Society, be as close to 0 for all three ratings with a priority of "uplight" of 0 and "backlight" as low as practicable.

NORTHERN LONG-EARED BAT AND TRICOLORED BAT PROTECTION (Continued)

Tree Removal AMMs

- *If additional cutting is proposed by the Contractor that is outside the scope of this contract, additional review is required by the MassDOT Highway Division's Environmental Services Section, and additional review and restrictions may be required by the USFWS.*
- Ensure tree removal is limited to that specified in project plans and ensure that contractors understand clearing limits and how they are marked in the field (e.g., install bright colored flagging/fencing prior to any tree clearing to ensure contractors stay within clearing limits).
- No tree cutting shall be conducted during the active season: **April 1 to October 31**.
- No tree cutting shall be conducted during the active season: **April 1 to October 31**, or if cutting inside of this timeframe is required, tree removal is limited to 10 or fewer trees per project at any time of year within 100 feet of existing road/rail surface and outside of documented roosting/foraging habitat or travel corridors; and a visual emergence survey must be conducted by *MassDOT Highway Division's Environmental Services Section or appointed representative with no bats observed*.
- Do not remove **documented** or NLEB and/or TCB roosts that are still suitable for roosting, or trees within 0.25 miles of roosts, or **documented** foraging habitat any time of year.
- The Contractor shall ensure all personnel working in on the project site are aware of all environmental commitments related to NLEB and/or TCB, including the **TOY** restriction. If this restriction needs to be waived at any location(s) the Resident Engineer shall send a locus map of the proposed work to MassDOT Highway Division's Environmental Services Section for review and a determination if the restriction can be waived.

Bridge AMM

- An inspection of the bridge for the presence of, or evidence of use by, bats shall be completed by the MassDOT Wildlife Unit prior to commencing bridge work. The Contractor shall notify the MassDOT Wildlife Unit no later than thirty (30) days prior to the start of work or reinitiating work on the bridge to provide adequate time for inspection. If bats are found to be present, or, if there is evidence of bat usage, work at the bridge shall not commence until the MassDOT Wildlife Unit has completed coordination with the U.S. Fish and Wildlife Service to determine the appropriate follow up or mitigative actions. If bridge work is not complete within 2 years of the initial bridge inspection, another inspection of the bridge for the presence of, or evidence of use by, bats shall be completed.

Structure AMMs

- This category includes manmade structures that may provide bat roosting or hibernation habitat that are not bridges (i.e., buildings, sheds, culverts). An inspection of the structure for the presence of, or evidence of use by, bats shall be completed by a Qualified Bat Consultant or MassDOT Biologist prior to commencing structure work. The Contractor shall notify the MassDOT Wildlife Unit no later than thirty (30) days prior to the start of work or reinitiating work to provide adequate time for inspection. If bats are found to be present, or, if there is evidence of bat usage, work at the bridge shall not commence until the MassDOT Wildlife and Endangered Species Unit has completed coordination with the USFWS to determine the appropriate follow up or mitigative actions.

NORTHERN LONG-EARED BAT AND TRICOLORED BAT PROTECTION (Continued)

Hibernacula AMMs

- For projects located within karst areas, on-site personnel will use best management practices, secondary containment measures, or other standard spill prevention and countermeasures to avoid impacts to possible hibernacula. Where practicable, a 300 foot buffer will be employed to separate fueling areas and other major containment risk activities from caves, sinkholes, losing streams, and springs in karst topography.

PROPRIETARY PRODUCTS

MassDOT has approved the use of the following proprietary products on this contract pursuant to M.G.L. c. 30, § 39M(b):

- Item 819.907/ IRD TRS WIM Traffic Recorder
- Item 819.907/ TE Connectivity Roadtrax BL Piezo Sensor
- Item 819.907/ PAT/IRD TRS Solar Harness
- Item 819.907/ Morningstar SunSaver SS-MPPT-15L Regulator
- Item 819.907/ Morningstar Ethernet MeterBus Convertor EMC-1 Ethernet Connectivity
- Item 819.907/ Sierra Wireless AirLink RV50X Modem

Approval letter has been filed with MassDOT.

HOLIDAY WORK RESTRICTIONS

(Supplementing Subsection 7.09)

The District Highway Director (DHD) may authorize work to continue during these specified time periods if it is determined by the District that the work will not negatively impact the traveling public. DHD may allow work in those areas on a case by case basis and where work is behind barrier and will not impact traffic

Below are the holiday work restrictions:

New Years Day (Federal Holiday)

No work on major arterial roadways from 5:00 AM on the day before until the normal start of business on the next subsequent business day. No work on local roadways on the holiday without permission by the DHD and the local police chief.

Martin Luther King's Birthday (Federal Holiday)

No work restrictions due to traffic concerns, however work on local roadways requires permission by the DHD and local police chief.

President's Day (Federal Holiday)

No work restrictions due to traffic concerns, however work on local roadways requires permission by the DHD and local police chief.

Evacuation Day (Suffolk County State Holiday)

No work restrictions due to traffic concerns.

Patriot's Day (State Holiday)

Work restrictions will be in place for Districts 3 and 6 along the entire Boston Marathon route and any other locations that the DHD in those districts determine are warranted so as to not to impact the marathon. All other districts work restrictions will be as per DHD.

Mother's Day

No work on Western Turnpike and Metropolitan Highway System from 5:00 AM on the Friday before, until the normal start of business on the following day.

Memorial Day (Federal Holiday)

No work on major arterial roadways from 5:00 AM on the Friday before, until the normal start of business on the following day.

HOLIDAY WORK RESTRICTIONS (Continued)

Bunker Hill Day (Suffolk County State Holiday)

No work restrictions due to traffic concerns.

Juneteenth

No work restrictions due to traffic concerns, however work on local roadways requires permission by the DHD and local police chief.

Independence Day (Federal Holiday)

No work on major arterial roadways from 5:00 AM on the day before until the normal start of business on the next subsequent business day. No work on local roadways on the holiday without permission by the DHD and the local police chief.

Labor Day (Federal Holiday)

No work on major arterial roadways from 5:00 AM on the Friday before, until the normal start of business on the following day.

Columbus Day (Federal Holiday)

No work on major arterials from 5:00 AM on the Friday before, until the normal start of business on the following day

Veterans' Day (Federal Holiday)

No work restrictions due to traffic concerns.

Thanksgiving Day (Federal Holiday)

No work on major arterials from 5:00 AM two days before until the normal start of business on the following Monday.

Christmas Day (Federal Holiday)

No work on major arterial roadways from 5:00 AM on the day before until the normal start of business on the next subsequent business day.

BIDDERS LIST

Pursuant to the provisions of 49 CFR Part 26.11 all official bidders will be required to report the names, addresses and telephone numbers of all firms that submitted bids or quotes in connection with this project. Failure to comply with a written request for this information within 15 business days may result in a recommendation to the Prequalification Committee that prequalification status be suspended until the information is received.

The Department will survey all firms that have submitted bids or quotes during the previous year prior to setting the annual goal and shall request that each firm report its age and gross receipts for the year.

BUILD AMERICA BUY AMERICA PREFERENCE

On Federally-aid projects the Buy America (23.CFR § 635.410) and Build America, Buy America Act (Pub. L. No. 117-58, §§ 70901-52). requires the following,

- (1) all iron and steel used in the project are produced in the United States--this means all manufacturing processes, from the initial melting stage through the application of coatings, must occur in the United States. Foreign steel and iron can be used if the cost of the materials does not exceed 0.1% of the total Contract cost or \$2,500, whichever is greater. The action of applying a coating to a covered material (i.e., steel and iron) is deemed a manufacturing process subject to Buy America. Coating includes epoxy coating, galvanizing, painting and any other coating that protects or enhances the value of a material subject to requirements of Build America, Buy America. Steel used for temporary support of excavation, including H piles, soldier piles, and sheeting when the steel is required to be left in place is subject to requirements of Build America, Buy America. Temporary steel, shall remain in place when it falls within the influence zone of the soil supporting any structure or railroad tracks.
- (2) all manufactured products used in the project are produced in the United States—this means the manufactured product was manufactured in the United States; and the cost of the components of the manufactured product that are mined, produced, or manufactured in the United States is greater than 55 percent of the total cost of all components of the manufactured product, unless another standard for determining the minimum amount of domestic content of the manufactured product has been established under applicable law or regulation; and

BUILD AMERICA BUY AMERICA PREFERENCE (Continued)

(3) all construction materials are manufactured in the United States—this means that all manufacturing processes for the construction material occurred in the United States. “Construction materials” includes an article, material, or supply—other than an item of primarily iron or steel; a manufactured product; cement and cementitious materials; aggregates such as stone, sand, or gravel; or aggregate binding agents or additives—that is or consists primarily of:

- non-ferrous metals,
- plastic and polymer-based products (including polyvinylchloride, composite building materials, and polymers used in fiber optic cables),
- glass (including optic glass),
- lumber; or
- drywall.

The Buy America preference only applies to articles, materials, and supplies that are consumed in, incorporated into, or affixed to an infrastructure project. As such, it does not apply to tools, equipment, and supplies, such as temporary scaffolding, brought to the construction site and removed at or before the completion of the infrastructure project. Nor does a Buy America preference apply to equipment and furnishings, such as movable chairs, desks, and portable computer equipment, that are used at or within the finished infrastructure project but are not an integral part of the structure or permanently affixed to the infrastructure project.

NOTE: The requirements for manufactured products indicated in paragraph (2) above are not in effect for this contract.

EMERALD ASH BORER ADVISORY

To the extent possible, all trees and brush shall be disposed on site, typically chipped and spread in place. When trees or brush must be removed, such as in urban, or otherwise populated areas, Contractor shall identify proposed location for disposal, and provide written notification to the Engineer for approval. Disposal shall be in city or town of project, or at minimum, within county, of construction operations.

EQUIVALENT SINGLE AXLE LOADS (ESALS)

The estimated traffic level to be used for SUPERPAVE HMA mixture designs for this contract, expressed in Equivalent Single Axle Loads (ESALs) for the design travel lane over a 20-year period, is 35.2 Million 18-kip (80-kn) ESALs.

SUBSECTION 8.14 UTILITY COORDINATION, DOCUMENTATION, AND MONITORING RESPONSIBILITIES

A. GENERAL

In accordance with the provisions of Section 8.00 Prosecution and Progress, utility coordination is a critical aspect to this Contract. This section defines the responsibility of the Contractor and MassDOT, with regard to the initial /utility relocation plan and changes that occur as the prosecution of the Work progresses. The Engineer, with assistance from the Contractor shall coordinate with Utility companies that are impacted by the Contractor's operations. To support this effort, the Contractor shall provide routine and accurate schedule updates, provide notification of delays, and provide documentation of the steps taken to resolve any conflicts for the temporary and/or permanent relocations of the impacted utilities. The Contractor shall provide copies to the Engineer of the Contractor communication with the Utility companies, including but not limited to:

- Providing advanced notice, for all utility-related meetings initiated by the Contractor.
- Providing meeting minutes for all utility-related meetings that the Contractor attends.
- Providing all test pit records.
- Request for Early Utility work requirements of this section (see below).
- Notification letters for any proposed changes to Utility start dates and/or sequencing.
- Written notification to the Engineer of all apparent utility delays within seven (7) Calendar Days after a recognized delay to actual work in the field – either caused by a Utility or the Contractor.
- Any communication, initiated by the Contractor, associated with additional Right-of-Way needs in support of utility work.
- Submission of completed Utility Completion Forms.

B. PROJECT UTILITY COORDINATION (PUC) FORM

The utility schedule and sequence information provided in the Project Utility Coordination Form (if applicable) is the best available information at the time of the bid and has been considered in setting the contract duration. The Contractor shall use all of this information in developing the bid price and the Baseline Schedule Submission, inclusive of the individual utility durations sequencing requirements, and any work that has been noted as potentially concurrent utility installations.

C. INITIATION OF UTILITY WORK

The Engineer will issue all initial notice-to-proceed dates to each Utility company based on either the:

- 1) Contractor's accepted Baseline Schedule
- 2) An approved Early Utility Request in the form of an Early Utility sub-net schedule (in accordance with the requirements of this Subsection)
- 3) An approved Proposal Schedule

C.1 - BASELINE SCHEDULE – UTILITY BASIS

The Contractor shall provide a Baseline Schedule submission in accordance with the requirements of Subsection 8.02 and inclusive of all of the information provided in the PUC Form that has been issued in the Contract documents. This is to include the utility durations, sequencing of work, allowable concurrent work, and all applicable considerations that have been depicted on the PUC Form.

SUBSECTION 8.14 (Continued)**C.2 – EARLY UTILITY REQUEST – (aka SUBNET SCHEDULE) PRIOR TO THE BASELINE**

All early utility work is defined as any anticipated/required utility relocations that need to occur prior to the Baseline Schedule acceptance. In all cases of proposed early utility relocation, the Contractor shall present all known information at the pre-construction conference in the form of a 'sub-net' schedule showing when each early utility activity needs to be issued a notice-to-proceed. The Contractor shall provide advance notification of this intent to request early utility work in writing at or prior to the Pre-Construction meeting. Prior to officially requesting approval for early utility work, the Contractor shall also coordinate with MassDOT and all utility companies (private, state or municipal) which may be impacted by the Contract. If this request is acceptable to the Utilities and to MassDOT, the Engineer will issue a notice-to-proceed to the affected Utilities, based on these accepted dates.

C.3 – PROPOSAL SCHEDULE - CHANGES TO THE PUC FORM

If the Contractor intends to submit a schedule (in accordance with MassDOT Standard Specifications, Division I, Subsection 8.02) that contains durations or sequencing that vary from those provided in the Project Utility Coordination (PUC) Form, the Contractor must submit this as an intended change, in the form of a Proposal Schedule and in accordance with MassDOT Standard Specifications, Division I, Subsection 8.02. These proposed changes are subject to the approval of the Engineer and the impacted utilities, in the form of this Proposal Schedule and a proposed revision to the PUC form. The Contractor shall not proceed with any changes of this type without written authorization from the Engineer, that references the approved Proposal Schedule and PUC form changes. The submission of the Baseline Schedule should not include any of these types of proposed utility changes and should not delay the submission of the Baseline Schedule. As a prerequisite to the Proposal Schedule submission, and in advance of the utility notification(s) period, the Contractor shall coordinate the proposed utility changes with the Engineer and the utility companies, to develop a mutually agreed upon schedule, prior to the start of construction.

D. UTILITY DELAYS

The Contractor shall notify the Engineer upon becoming aware that a Utility owner is not advancing the work in accordance with the approved utility schedule. Such notice shall be provided to the Engineer no later than seven (7) calendar days after the occurrence of the event that the Contractor believes to be a utility delay. After such notice, the Engineer and the Contractor shall continue to diligently seek the Utility Owner's cooperation in performing their scope of Work.

In order to demonstrate that a critical path delay has been caused by a third-party Utility, the Contractor must demonstrate, through the requirements of the monthly Progress Schedule submissions and the supporting contract records associated with Subsection 8.02, 8.10 and 8.14, that the delays were beyond the control of the Contractor.

SUBSECTION 8.14 (/Continued)

All documentation provided in this section is subject to the review and verification of the Engineer and, if required, the Utility Owner. In accordance with MassDOT Specifications, Division I, Subsection 8.10, a Time Extension will be granted for a delay caused by a Utility, only if the actual duration of the utility work is in excess of that shown on the Project Utility Coordination Form, and only if;

- 1) proper Notification of Delay was provided to MassDOT in accordance with the time requirements that are specified in this Section
- 2) the utility delay is a critical path impact to the Baseline Schedule (or most recently approved Progress Schedule)

E. LOCATION OF UTILITIES

The locations of existing utilities are shown on the Contract drawings as an approximation only. The Contractor shall perform a pre-construction utility survey, including any required test pits, to determine the location of all known utilities no later than thirty (30) calendar days before commencing physical site work in the affected area.

F. POST UTILITY SURVEY – NOTIFICATION

Following completion of a utility survey of existing locations, the Contractor will be responsible to notify the Engineer of any known conflicts associated with the actual location of utilities prior to the start of the work. The Engineer and the Contractor will coordinate with any utility whose assets are to be affected by the Work of this Contract. A partial list of utility contact information is provided in the Project Utility Coordination Form.

G. MEETINGS AND COOPERATION WITH UTILITY OWNERS

The Contractor shall notify the Engineer in advance of any meeting they initiate with a Utility Owner's representative to allow MassDOT to participate in the meeting if needed.

Prior to the Pre-Construction Meeting, the Contractor should meet with all Utility Owners who will be required to perform utility relocations within the first 6 months of the project, to update the affected utilities of the Project Utility Coordination Form and all other applicable Contract requirements that impact the Utilities. The Contractor shall copy the Engineer on any correspondence between the Utility Owner and the Contractor.

H. FORCE ACCOUNT / UTILITY MONITORING REQUIREMENTS

The Engineer will be responsible for recording daily Utility work force reports. The start, suspension, re-start, and completion dates of each of the Utilities, within each phase of the utility relocation work, will be monitored and agreed to by the Engineer and the Contractor as the work progresses.

I. ACCESS AND INSPECTION

The Contractor shall be responsible for allowing Utility owners access to their own utilities to perform the relocations and/or inspections. The Contractor shall schedule their work accordingly so as not to delay or prevent each utility from maintaining their relocation schedule.

COMPLIANCE WITH THE NATIONAL DEFENSE AUTHORIZATION ACT

(Supplementing Subsection 7.01)

On all projects, the “Prohibition on Certain Telecommunications and Video Surveillance Services or Equipment” Regulation (2 CFR 200.216) prohibits the Contractor from using or furnishing the following telecommunications equipment or services:

- Telecommunications equipment produced by Huawei Technologies Company or ZTE Corporation (or any subsidiary or affiliate of such entities).
- For the purpose of public safety, security of government facilities, physical security surveillance of critical infrastructure, and other national security purposes, video surveillance and telecommunications equipment produced by Hytera Communications Corporation, Hangzhou Hikvision Digital Technology Company, or Dahua Technology Company (or any subsidiary or affiliate of such entities).
- Telecommunications or video surveillance services provided by such entities or using such equipment.
- Telecommunications or video surveillance equipment or services produced or provided by an entity that the Secretary of Defense, in consultation with the Director of the National Intelligence or the Director of the Federal Bureau of Investigation, reasonably believes to be an entity owned or controlled by, or otherwise connected to, the government of a covered foreign country.

This prohibition applies to all products manufactured by the aforementioned companies, including any individual components or parts.

By submitting a bid on a project, the Contractor certifies that all work will be in compliance with the terms of 2 CFR 200.216. The Contractor shall submit a COC indicating compliance with the above provisions for all telecommunications equipment or services included in the Contract.

/

Payment for the item in which the materials are incorporated may be withheld until these COCs are received. Any cost involved in furnishing the certificate(s) shall be borne by the Contractor.

SUBSECTION 8.02 SCHEDULE OF OPERATIONS

Replace this subsection with the following:

An integrated cost and schedule controls program shall be implemented by the Contractor to track and document the progress of the Work from Notice to Proceed (NTP) through the Contractor Field Completion (CFC) Milestone. The Contractor’s schedules will be used by the Engineer to monitor project progress, plan the level-of-effort required by the Department’s work force and consultants and as a critical decision-making tool. Accordingly, the Contractor shall ensure that it complies fully with the requirements specified herein and that its schedules are both accurate and updated as required by the specification throughout the life of the project. Detailed requirements are provided in Division II, Section 722 Construction Scheduling.

SECTION 722
CONSTRUCTION SCHEDULING
DESCRIPTION

722.20 General

The Contractor's approach to prosecution of the Work shall be disclosed to the Department by submission of a Critical Path Method (CPM) schedule and a cost/resource loaded Construction Schedule as defined by the schedule type set forth below. These requirements are in addition to any requirements imposed in other sections.

This section establishes the requirement for scheduling submissions. There are four schedule types identified as types A, B, C and D. The schedule type applicable to this project is established in the project special provisions.

All schedules shall be prepared and submitted in accordance with this specification and the instructions contained in the Construction Schedule Toolkit located on the MassDOT-Highway Division website at <https://www.mass.gov/info-details/massdot-highway-contractors-schedule-toolkit>.

Type A –

- Schedule Planning Session
- Baseline CPM Schedule
- Monthly Update CPM Schedule
- Short-term Construction Schedule
- Contract Schedule Update Meeting
- Cost-loaded & Resource Loaded CPM
- Resources Graphic Reporting
- Cash Flow Projections from the CPM
- Cash Flow Charts
- Monthly Projected Spending Report (PSR)
- Contractor-furnished CPM software and computer

Type B –

- Schedule Planning Session
- Baseline CPM Schedule
- Monthly Update CPM Schedule
- Short-term Construction Schedule
- Contract Schedule Update Meeting
- Cost-loaded & Resource Loaded CPM
- Monthly Projected Spending Report (PSR)
- Contractor-furnished CPM software and computer

Type C –

- Schedule Planning Session
- Baseline CPM Schedule
- Monthly Update CPM Schedule
- Short-term Construction Schedule
- Contract Schedule Update Meeting
- Monthly Projected Spending Report (PSR)
- Contractor-furnished CPM software and computer

SECTION 722 (Continued)**Type D -**

- Bar chart schedule updated monthly or at the request of the Engineer
- Short-term Construction Schedule
- Monthly Projected Spending Report (PSR)

EQUIPMENT, PERSONNEL**722.40 General****A. Software Requirements**

The Contractor shall use Primavera P6 computer scheduling software.

In addition to the requirements of Section 740 – Engineer’s Field Office and Equipment, the Contractor shall provide to the Department one (1) copy of the scheduling software, one (1) software license and one (1) computer capable of running the scheduling software for the duration of the Contract. This computer and software shall be installed in the Engineer’s Field Office. The computer and software shall be maintained and serviced at no additional cost to the Department.

B. Scheduler Requirements

The Scheduler shall be approved by the Engineer.

For Type A, B and C Schedules the name of the Contractor’s Project Scheduler together with his/her qualifications shall be submitted to the Department for approval by the Engineer within seven (7) Calendar Days after NTP. The Project Scheduler shall have a minimum of five (5) years of project CPM scheduling experience, three (3) years of which shall be on projects of similar scope and value as the project for which the Project Scheduler is being proposed. References shall be provided from past projects that can attest to the capabilities of the Project Scheduler.

SCHEDULING METHODS**722.60 General****A. Schedule Planning Session**

The Contractor shall conduct a schedule planning session prior to submission of the Baseline Schedule. This session will be attended by the Department and its consultants. During this session, the Contractor shall present its planned approach to the project including, but not limited to:

1. the Work to be performed by the Contractor and its subcontractors;
2. the planned construction sequence and phasing; planned crew sizes;
3. summary of equipment types, sizes, and numbers to be used for each work activity;
4. all early work related to third party utilities;
5. identification of the most critical submittals and projected submission timelines;
6. estimated durations of major work activities;
7. the anticipated Critical Path of the project and a summary of the activities on that Critical Path;
8. a summary of the most difficult schedule challenges the Contractor is anticipating and how it plans to manage and control those challenges;

SECTION 722 (Continued)

9. a summary of the anticipated quarterly cash flow over the life of the project.

This will be an interactive session and the Contractor shall answer all questions that the Department and its consultants may have. The Contractor shall provide a written summary of the information presented and discussed during the session to the Engineer. The Contractor's Baseline Schedule and accompanying Schedule Narrative shall incorporate the information discussed at this Schedule Planning Session.

B. Schedule Reviews by the Department**1. Baseline Schedule Reviews**

The Engineer will respond to the Baseline Schedule Submission within thirty (30) Calendar Days of receipt providing comments, questions and/or disposition that either accepts the schedule or requires revision and resubmittal. Rejected Baseline Schedules shall be resubmitted within fifteen (15) Calendar Days after receipt of the Engineer's comments.

2. Contract Progress Schedule / Monthly Update Reviews / Recovery Schedules

The Engineer will respond to each submittal within twenty-one (21) Calendar Days. Rejected schedules shall be resubmitted by the Contractor within five (5) Calendar Days after receipt of the Engineer's comments.

The Engineer's review comments shall not be construed as direction to change the Contractor's means and methods. The review and acceptance of the CPM schedule does not relieve the Contractor of the responsibility for accomplishing the work within the contract required completion dates. Omissions and errors in the accepted CPM schedule shall not excuse performance less than that required by the Contract.

722.61 Schedule Content and Preparation Requirements

All schedules shall be prepared and submitted in accordance with the instructions contained in the Construction Schedule Toolkit located on the MassDOT-Highway Division website at:

<https://www.mass.gov/info-details/massdot-highway-contractors-schedule-toolkit>

and the following:

A. LOGIC

The schedules shall divide the Work into activities with appropriate logic ties to show:

1. conformance with the requirements of this Section and Division I, Subsection 8.02 - Schedule of Operations
2. the Contractor's overall approach to the planning, scheduling, and execution of the Work
3. conformance with any additional sequences of Work required by the Contract Documents, including, but not limited to, Subsection 8.03 - Prosecution of Work and Subsection 8.06 – Limitations of Operations.

SECTION 722 (Continued)**B. ACTIVITIES**

The schedule shall clearly define the progression of the Work from the Notice to Proceed (NTP) to Contractor Field Completion (CFC) by using separate activities, or including attributes within appropriate activities, to address each of the following:

1. Notice to Proceed
2. Work Breakdown Structure
3. The Critical Path is clearly defined and organized.
4. Float shall be clearly identified.
5. Detailed activities to satisfy permit requirements.
6. Subcontractor approvals at fifteen (15) Calendar Days from submittal to response
7. The preparation and submission of shop drawings, procedures, and other required submittals, with a planned duration that is to be demonstrated to the Engineer as reasonable.
8. The review and return of shop drawings, procedures, and other required submittals, approved or with comments, the duration of which shall be thirty (30) Calendar Days, unless otherwise specified or as approved by the Engineer.
9. Procurement of fabricated materials and equipment with long lead times, including time for review and approval of submittals required before procuring and fabricating.
10. Each component of the Work defined by specific activities.
11. Right-of-Way (ROW) takings that have been identified in the Contract.
12. Early Utility Relocation (by others) that has been identified in the Contract.
13. Interfaces with adjacent work, utility companies, other public agencies, sensitive abutters, and/or any other third-party work affecting the Contract.
14. Utility work to be performed in accordance with the Project Utility Coordination (PUC) Form as provided in Section 8.14 - Utilities Coordination, Documentation and Monitoring Responsibilities
15. Access Restraints – restrictions on access to areas of the Work that are defined by the Department in the bid package, in Subsection 8.06 – Limitations of Operations or elsewhere in the Contract
16. Limitations of Work – time of year restrictions and any other limitations identified in the contract
17. Traffic work zone set-up and removal, night work and phasing
18. Material Certifications
19. Milestones listed in Subsection 8.03 - Prosecution of Work or elsewhere in the Contract Documents
20. For Type A and B Contracts only: All items to be paid for, including all Unit Price and Lump Sum pay items, shall be identified by activity. This shall include all non-construction activities such as engineering work; purchase of permanent materials and equipment, purchase of structural steel stock, equipment procurement, equipment delivery to the site or storage location and the representative amount of overhead/indirect costs that was included in the Contractor's Bid Prices.

SECTION 722 (Continued)

21. Contractor's request for validation of FBU (ready to open to traffic)
22. Full Beneficial Use (FBU) Contract Milestone per the following requirements:
The majority of contract Work has been completed and the asset(s) has been opened for full multi-modal transportation use, except for limited contract work items that do not materially impair or hinder the intended public use of the transportation facility. All anticipated lane takings have been completed, except for minor, short term work items and as defined in Subsection 8.03 - Prosecution of Work
23. The Department's confirmation of completed work to allow for FBU.
24. Contractor's request for validation of Substantial Completion
25. Department generated punch list of twenty-one (21) Calendar Days
26. Substantial Completion Contract Milestone as defined in the standard specifications.
27. Punch list Completion Period of at least thirty (30) Calendar Days per the requirements of Subsections 5.11 - Final Acceptance, 7.15 - Claims Against Contractors for Payment of Labor, Materials and Other Purposes
28. Contractor confirmation that all punchlist work and documentation has been completed.
29. Physical Completion of the Work Contract Milestone per the requirements of Subsections 5.11 - Final Acceptance and 8.03 - Prosecution of Work
30. Documentation Completion per the requirements of Subsections 5.11 - Final Acceptance and 8.03 - Prosecution of Work
31. Contractor Field Completion Contract Milestone (which can also be considered the completion date) per the following requirements: All physical contract Work is complete including punchlist. The Contractor has fully de-mobilized from field operations and as defined in Subsection 5.11

C. EARLY AND LATE DATES

Early Dates shall be based on proceeding with the Work or a designated part of the Work exactly on the date when the corresponding Contract Time commences. Late Dates shall be based on completing the Work or a designated part of the Work exactly on the corresponding Contract Time, even if the Contractor anticipates early completion.

D. DURATIONS

Activity durations shall be in Work Days. Planned Original Durations shall be established with consideration of resources and production rates that correspond to the Contractor's Bid Price. Within all of the Department-required schedules, the Contractor shall plan the Work using durations for all physical construction activities of no less than one (1) Work Day and no greater than fourteen (14) Work Days, unless approved by the Engineer as part of the Baseline Schedule Review.

SECTION 722 (Continued)

Should there be an activity with a duration that is determined by the Engineer to be unreasonable, the Contractor will be asked to provide a basis of the duration using bid documents, historic production rates for similar work, or other form of validation that is acceptable to the Engineer. Should the Contractor and the Engineer be unable to agree on reasonable activity durations, the Engineer will, at a minimum, note the disagreement in the Baseline Schedule Review along with a duration the Engineer considers reasonable and the basis for that duration. A schedule that contains a substantial number of activities with durations that are deemed unreasonable by the Engineer will not be accepted.

E. MATERIALS ON HAND

The Contractor shall identify in the Baseline Schedule all items of permanent materials (Materials On Hand) for which the Contractor intends to request payment prior to the incorporation of such items into the Work.

F. ACTIVITY DESCRIPTIONS

The Contractor shall use activity descriptions in all schedules that clearly describe the work to be performed using a combination of words, structure numbers, station numbers, bid item numbers, work breakdown structure (WBS) and/or elevations in a concise and compact label.

G. ACTIVITY IDENTIFICATION NUMBERS

The Contractor shall use the activity identification numbering system specified in the MassDOT Highway Division Contractor Construction Schedule Toolkit.

H. ACTIVITY CODES

The Contractor shall use the activity codes specified in the MassDOT Highway Division Contractor Construction Schedule Toolkit.

I. CALENDARS

Different calendars may be created and assigned to all activities or to individual activities. Calendars define the available hours of work in each Calendar Day, holidays and general or project-specific non-Work Days such as Fish Migration Periods, time-of-year (TOY) restrictions and/or area roadway restrictions. All calendars shall extend two years beyond the current project completion date.

Project Special Provisions identify specific calendar restrictions some examples of special calendars include, but are not limited to:

- Winter Shutdown Period, specific work is required by separate special provision to be performed during the winter. See Special Provision 8.03 (if applicable)
- Peak traffic hours on heavily traveled roadways. This shall be from 6:30 am to 9:30 am and from 3:30 pm to 7:00 pm, unless specified differently elsewhere in the Contract.
- Special requirements by sensitive abutters, railroads, utilities and/or other state agencies as defined in the Contract.
- Planting seasons for trees, shrubs and grasses and wetlands mitigation work.

SECTION 722 (Continued)

- Cape Cod and the Islands Summer Roadway Work Restrictions: A general restriction against highway and bridge construction is enforced between Memorial Day and Labor Day, unless otherwise directed by the Engineer. Cape Ann Summer Roadway Work Restrictions: While there are no general restrictions for Cape Ann as there are for Cape Cod and the Islands, project-specific restrictions may be enforced.
- Turtle and/or Fish Migration Periods and/or other in-water work restrictions: Refer to the Project Special Provisions for specific restrictions.
- Working over Waterways Restricted Periods.
- Night-time paving and striping operations, traffic, and temperature restrictions.
- Utility Restrictions shall be as specified within the Contract.

J. FLOAT

For the calculation of float in the CPM schedule, the setting for *Retained Logic* is required for all schedule submissions, starting with the Baseline Schedule Submission. Should the Contractor have a reason to propose that an alternative calculation setting such as *Progress Override* be used, the Contractor shall obtain the Engineer's approval prior to modifying to this setting.

K. COST AND RESOURCE LOADING (Types A and B only)

For all Type A and B Schedules, the Contractor shall provide a cost and resource-loaded schedule with an accurate allocation of the costs and resources necessary to complete the Work. The costs and resources shall be assigned to all schedule activities in order to enable the Contractor to efficiently execute the Contract requirements and the Engineer to validate the original plan, monitor progress, provide cash flow projections, and analyze delays.

1. Each schedule activity shall have an assigned cost that accurately represents the value of the Work. Each schedule activity shall have its resources assigned to it by craft and the anticipated hours to accomplish the work. Each schedule activity's equipment resources shall be assigned to it by equipment type and hours operated. Front-loading or other unbalancing of the cost distribution will not be permitted.
2. The sum of the cost of all schedule activities shall be equal to the Contractor's Bid Price.
3. Indicating the labor hours per individual, per day, by craft and equipment hours/day will be acceptable.
4. The Engineer reserves the right to use the cost-loading as a means to resolve changes, disputes, time entitlement evaluations, increases or decreases in the scope of Work, unit price renegotiations and/or claims.
5. For all Type A and B Schedules, all subnets, fragnets, Proposal Schedules, and Recovery Schedules shall be cost and resource- loaded to help to quickly validate and monitor the duration of the Work to be performed.
6. For Type A Schedules, cost-loading of the schedule will also be used for cash flow projection purposes.
7. The cost-loading of each activity shall indicate the portion of the cost for that activity that is applicable to a specific bid item (cost account.) The total cost for each cost account must equal the bid item price.

SECTION 722 (Continued)**L. NOT TO BE USED IN THE CONTRACTOR'S CPM SCHEDULE**

1. Milestones or constraint dates not specified in the Contract.
2. Scheduled work not required for the accomplishment of a Contract Milestone
3. Use of activity durations, logic ties and/or sequences deemed unreasonable by the Engineer.
4. Delayed starts of follow-on trades.
5. Float suppression techniques.
6. Leads such as leads, lags, SS, SF, & FF relationships without the expressed permission of the Department.

722.62 Submittal Requirements

All schedules shall be prepared and submitted in accordance with the requirements listed below.

Each monthly Contract Progress Schedule submittal shall be uniquely identified.

Each Submission shall, at a minimum, include the following:

- a. Narrative
- b. Schedule submittals shall be signed by the Scheduler
- c. Schedule Printout - All Activities
- d. Schedule Printout - Critical Path Layout
- e. Schedule Printout - Remaining Work
- f. Schedule Printout - Top 3 Float Path
- g. Work Breakdown Structure (WBS) Summary
- h. Project Spending Report (PSR) in Portable Document Format (.PDF)
- i. Project Spending Report (PSR) in Microsoft Excel spreadsheet (.XLS)
- j. Oracle Primavera P6 Schedule File (.XER)

All digital file submittals will be labeled with the following information.

- Contract Number
- Project Number
- Project locations (i.e., town(s))
- Brief description
- Submittal description (i.e., UP07)
- Data Date (MM-DD-YY)
- File Description (i.e., Critical Path)

Example: C110464 (P606309) - Orange Route 2 over 202 – UP23 (07-15-22) - Critical Path

A. Narratives

A written narrative shall be submitted with every schedule submittal. The narrative shall:

1. itemize and describe the flow of work for all activities on the Critical Path in a format that includes any changes made to the schedule since the previous Contract Progress Schedule / Monthly Update or the Baseline Schedule, whichever is most recent.
2. provide a description of any specification requirements that are not being followed. Identify those that are improvements and those that are not considered to be meeting the requirements.

SECTION 722 (Continued)

3. provide all references to any Notice of Delay that has been issued, within the time period of the Contract Progress Schedule Update, by letter to the Engineer. Note that any Notice of Delay that is not issued by letter will not be recognized by the Engineer. See Subsection 722.64.A – Notice of Delay.
4. provide a description of each third-party utility’s planned vs. actual progress and note any that are trending late or are late per the durations and commitments as provided in the PUC Form; provide a description of the five (5) most important responses needed from the Department and the need date for the responses in order to maintain the current Schedule of Record.
5. provide a description of all critical issues that are not within the control of the Contractor or the Department (third party) and any impact they had or may have on the Critical Path.
6. provide a description of any possible considerations to improve the probability of completing the project early or on time.
7. compare Early and Late Dates for activities on the Critical Path and describe reasons for changes in the top three (3) most critical paths.
8. describe the Contractor’s plan, approach, methodologies, and resources to be employed for completing the various operations and elements of the Work for the top three (3) most critical paths. For update schedules, describe and propose changes to those plans and verify that a Proposal Schedule is not required.
9. describe, in general, the need for shifts that are not 5 days/week, 8 hours/day, the holidays that are inserted into each calendar and a tabulation of each calendar that has been used in the schedule.
10. describe any out-of-sequence logic and provide an explanation of why each out-of-sequence activity does not require a correction, if one has not been provided, and an adequate demonstration that these changes represent the basis of how these activities will be built, including considerations for resources, dependencies, and previously approved production rates.
11. identify any possible duration increases resulting from actual or anticipated unit price item quantity overruns as compared to the baseline duration, with a corresponding suggestion to mitigate any possible delays to the Critical Path. If the delay is anticipated to impact the Critical Path, refer to Subsections 4.06 – Increased or Decreased Contract Quantities and 8.10 – Determination and Extension of Contract Time for Completion and submit a letter to the Engineer notifying of a potential delay.
12. include a schedule log consisting of the name of the schedule, the data date and the date submitted.
13. include and describe any notifications, communications and coordination meetings with third-parties such as utility companies that occurred from the last update including personnel names, job titles and contact information, date of meeting(s)/correspondence(s), topics discussed, and reasons the third party provided for deviations from the PUC form.

SECTION 722 (Continued)**B. CPM Bar Charts**

One (1) timescaled bar chart containing all activities shall be prepared and submitted using a scale that yields readable plots and that meets the requirements of Subsection 722.61 – Schedule Content and Preparation Requirements. Activities shall be linked by logic ties and shown on their Early Dates. Critical Paths shall be highlighted, and Total Float shall be shown for all activities.

A second timescaled bar chart shall also be prepared containing only the Critical Path or, if the Critical Path is not the longest path, the Longest Path using a scale that yields readable plots and that meets the requirements of Subsection 722.61 – Schedule Content and Preparation Requirements. Activities shall be linked by logic ties and shown on their Early Dates. Total Float shall be shown for all activities.

C. Detailed Activity Schedule Comparisons

A Detailed Activity Schedule Comparison (DASC) is a simple reporting tool in the format of a graphical report that will provide Resident Engineers with immediate, timely and up-to-date information. The DASC consists of an updated bar chart that overlays the current time period's bar chart onto the previous time period's bar chart for an easily read comparison of progress during the present and previous reporting periods.

D. Activity Cost Report and Monthly Cash Flow Projections (Type A only)

With each Contractor Quantity Estimate (CQE), the Contractor shall submit an Activity Cost Report and Cash Flow Projection that includes all activities grouped by Contract Bid Item.

The Activity Cost Report shall be generated from the Schedule of Record and shall be the basis of the Monthly Cash Flow Projection. Within each contract Bid Item, activities shall be sequenced by ascending activity identification number and shall show:

1. activity ID and description,
2. forecast start and finish dates for each activity and,
3. when submitted as a revised schedule, actual start, and finish dates for each completed activity.
4. any variance to the estimated contract quantity shall be shown.

E. Resource Graphs (Type A only)

Monthly and cumulative resource graphs for the remaining Contract period using the Early Dates and Late Dates in the Contract Progress Schedule shall be included as part of each schedule submittal.

SECTION 722 (Continued)**F. Projected Spending Reports**

A Projected Spending Report (PSR) shall be prepared and submitted monthly. The PSR shall indicate the monthly spending (cash flow) projection for each month from NTP to Contractor Field Completion (CFC). Each month's actual spending shall be calculated using all CQEs paid during that month. The Projected Spending Report (PSR) shall be depicted in a tabular format and provided in both an .XLS and .PDF.

722.63. Progress Schedule Requirements**A. Baseline Schedule**

The Baseline Schedule shall be due thirty (30) Calendar Days after Notice to Proceed (NTP). The Baseline Schedule shall only reflect the Work awarded to the Contractor and shall not include any additional work involving Extra Work Orders or any other type of alleged delay. The Baseline Schedule shall be prepared and submitted in accordance with Subsections 722.61 - Schedule Content and Preparation Requirements and 722.62 - Submittal Requirements. Once the Baseline Schedule has been accepted by the Engineer, with or without comments, it shall represent the as-planned schedule for the Work and become the Contract Progress Schedule of Record until such time as the schedule is updated or revised under Subsections 722.63.C - Contract Progress Schedules / Monthly Updates, 722.64.C - Recovery Schedules and 722.64.D - Proposal Schedules.

The Cost and Resource-Loading information (Types A and B only) shall be provided by the Contractor within forty-five (45) Calendar Days after NTP.

The Engineer's review comments on the Baseline Schedule and the Contractor's responses to them will be maintained for the duration of the Contract and will be used by the Engineer to monitor the Contractor's work progress by comparing it to the Contract Progress Schedule / Monthly Update.

B. Interim Progress-Only Schedule Submissions

The first monthly update of the Contract Progress Schedule/Monthly Update is due within seventy (70) Calendar Days after Notice to Proceed (NTP.) The Baseline Schedule review period ends at sixty (60) Calendar Days after NTP, see Subsection 722.60.B - Schedule Reviews by the Department. If the Baseline Schedule has not been accepted within sixty (60) Calendar Days after NTP, an Interim Progress-Only Schedule shall be due within seventy (70) Calendar Days after NTP. The purpose of the Interim Progress-Only Schedule is to document the actual progress of all activities, including non-construction activities, from NTP until the Baseline Schedule is accepted.

SECTION 722 (Continued)**C. Contract Progress Schedules / Monthly Updates**

The first Contract Progress Schedule shall be submitted by the Contractor no later than seventy (70) Calendar Days after NTP. The data date for this first Progress Schedule shall be two months (approximately sixty (60) Calendar Days) after NTP. Subsequent Progress Schedules shall be submitted monthly.

Each Contract Progress Schedule shall reflect progress up to the data date. Updated progress shall be limited to asbuilt sequencing and asbuilt dates for completed and inprogress activities. Asbuilt data shall include actual start dates, remaining Work Days and actual finish dates for each activity, but shall not change any activity descriptions, the Original Durations, or the Original Resources (as planned at the time of bid), without the acceptance of the Engineer. If any activities have been completed out-of-sequence, the Contractor shall propose new logic ties for affected in-progress and future activities that accurately reflect the previously approved sequencing. Alternatively, the Contractor may submit to the Engineer for approval an explanation of why an out-of-sequence activity does not require a correction and an adequate demonstration that the changes accurately represent how the activities will be built, including considerations for resources, dependencies, and previously approved production rates. Once approved by the Engineer, the Contractor may incorporate the changes in the next Contract Progress Schedule/Monthly Update with the affected activities clearly identified and explained in the Schedule Narrative.

No revisions to logic ties, sequence, description, or duration of future activities; or planned resource costs shall be made without prior approval by the Engineer.

Any proposed logic changes for in-progress or future activities shall be submitted to the Engineer for approval before being incorporated into a Contract Progress Schedule. The logic changes must be submitted using a Proposal Schedule or a schedule fragnet submission. Once approved by the Engineer, the Contractor may incorporate the logic in the next Contract Progress Schedule/Monthly Update with the affected activities clearly identified and explained in the Schedule Narrative.

For any proposed changes to the original sequence, description or duration of future activities, the Contractor shall submit to the Engineer for approval an explanation of how the proposed description or duration change reflects how the activity will be progressed, including considerations for resources and previously approved production rates. Any description or duration change that does not accurately reflect how the activity will be progressed will not be approved by the Engineer. Once approved by the Engineer, the Contractor may incorporate the changes in the next Contract Progress Schedule/Monthly Update with the affected activities clearly identified and explained in the Schedule Narrative.

Contract Progress Schedules that extend performance beyond the Contract Time or beyond any Contract Milestone shall not be approved by the Engineer. The Contractor shall submit a Recovery Schedule, or a Time Entitlement Analysis, if any Contract Progress Schedule/Monthly Update indicates a failure to meet the Contract Dates.

SECTION 722 (Continued)**D. Short-Term Construction Schedule**

The Contractor shall provide a Short-Term Construction Schedule that details daily work activities, including any multiple shift work that the Contractor intends to conduct, in a spreadsheet format. The daily activities shall directly correspond to the Contract Progress Schedule activities, with a matching reference to the activity identification number in the Contract Progress Schedule and may be at a greater level of detail. The Short-Term Construction Schedule shall be submitted every two weeks. It shall display all work for a thirty-five (35) Calendar Day period consisting of completed work for the two (2) week period prior and all planned work for the following three (3) week period. The initial submission shall be provided no later than thirty (30) Calendar Days after NTP or as required by the Engineer.

The Contractor shall be prepared to discuss the Short-Term Construction Schedule, in detail, with the Engineer in order to coordinate field inspection staff requirements, the schedule of work affecting abutters and any corresponding work with affected utilities. Short-Term Construction Schedules shall be prepared and submitted in accordance with Subsections 722.61 - Schedule Content and Preparation Requirements and 722.62 - Submittal Requirements.

722.64 Impacted Schedule Requirements**A. Notice of Delay**

The Contractor shall notify the Engineer in writing, with copies to the District and State Construction Engineers, within fifteen (15) of the start of any delays to the Critical Path that are caused by actions or inactions that were not within the control of the Contractor. Delay notifications that are not provided in a letter to the Engineer, such as a delay notification in the schedule narrative, will not be recognized as contractual notice in the determination of any Time Extension related to the impacts to the work associated with this specific alleged delay. Should such a delay continue for more than one (1) week, the Contractor shall note it in the Schedule Narrative until the delay is no longer impacting the Critical Path for the completion of the Contract Milestones. The Engineer will evaluate the alleged delay and its impact and will respond to the Contractor within ten (10) Calendar Days after receipt of a notice of delay.

B. Time Entitlement Analysis

A Time Entitlement Analysis (TEA) shall consist of a descriptive narrative, prepared in accordance with Subsection 722.62.A - Narratives, and an as-built CPM schedule, which may be in the form of a schedule fragnet that has been developed from the project's Contract Progress Schedule of Record, and illustrates the impact of a delay to the Critical Path, Contract Milestones and/or Contract Completion Date as required in Subsection 8.10 - Determination and Extension of Contract Time for Completion. TEAs shall also be used to determine the schedule impact of proposed Extra Work Orders (EWO) as also required in Subsection 8.10.

TEAs shall be prepared and submitted in accordance with the requirements of Subsections 722.61 - Schedule Content and Preparation Requirements and 722.62 - Submittal Requirements and shall be based on the Contract Progress Schedule of Record applicable at the start of the delay or impact from an EWO. A TEA fragnet must start with a specific new activity describing the work contained in either a Notice of Delay previously submitted to the Department per Subsection 722.64.A - Notice of Delay or an EWO.

SECTION 722 (Continued)

TEAs shall be submitted:

1. as part of any Extra Work Order that may impact Contract Time,
2. with a request for a Time Extension,
3. within fifteen (15) Calendar Days after a request for a TEA by the Engineer for any other reason.

A TEA shall be submitted to the Engineer before any Time Extension is granted to the Contractor. Time Extensions will not be granted unless the TEA accurately reflects an evaluation of all past delays and the actual events that occurred that impacted the Critical Path. The TEA must also demonstrate a plan for the efficient completion of all of the remaining work through an optimized CPM Schedule. The analysis shall include all delays, including Contractor-caused delays, and shall be subdivided into timeframes and causes of delays.

TEAs shall incorporate any proposed activities, logic ties, resource considerations, and activity costs required to demonstrate the schedule impacts most efficiently in addition to detailing all impacts to existing activities, logic ties, the Critical Path, Contract Milestones, and the Contract Completion Date. In addition, TEAs shall accurately reflect any changes made to activities, logic ties, restraints, and activity costs, necessitated by an Extra Work Order or other schedule impact, for the completion of the remaining work. The Contractor shall provide TEAs that demonstrate that all delays have been mitigated to the fullest extent possible without requiring an Equitable Adjustment to the original bid basis.

All TEAs shall clearly indicate any overtime hours, additional shifts and the resources that are proposed to be incorporated in the schedule. The Engineer shall have final discretion over the use of overtime hours and additional shifts. The Engineer shall have the right to require that overtime hours and/or additional shifts be used to minimize the duration of Time Extensions if it is determined to be in the best interest of the Department to do so.

When accepted, the changes included in a TEA shall be incorporated into the next Contract Progress Schedule per the requirements of Subsection 722.63.C - Contract Progress Schedules / Monthly Updates. During the review of any TEA, all Contract Progress Schedules shall continue to be submitted as required.

The Engineer may request that the Contractor prepare a Proposal Schedule or a Recovery Schedule to further mitigate any delays that are shown in the accepted TEA or Contract Progress Schedule.

C. Recovery Schedules

The Contractor shall promptly report to the Engineer all schedule delays during the prosecution of the Work. ~~Contract Progress Schedules that predict performance extended beyond the Contract Time or beyond any Contract Milestone shall not be approved as the schedule of record.~~ This requirement is critical to the Department's ability to make informed decisions regarding Contract Time and costs.

The Contractor shall submit a Recovery Schedule within fifteen (15) Calendar Days of a Contract Progress Schedule submission that shows failure to meet the Contract Dates unless a recovery schedule is waived by the Department. Waiving the recovery schedule does not relieve the contractor of the responsibility for the delay. The Department may revoke the waiver of a Recovery Schedule, at which time a Recovery Schedule shall be submitted within fifteen (15) Calendar Days of the Contractor being notified.

Changes represented in accepted Recovery Schedules shall be incorporated into the next Contract Progress Schedule.

SECTION 722 (Continued)**D. Proposal Schedules**

A Proposal Schedule is an alternative schedule used to evaluate proposed changes to the Contract scope or significant alternatives to previously approved approaches to complete the Work, which may include changes to activity durations, logic, and sequence. For Types A and B Schedules, the Proposal Schedule shall be cost and resource loaded.

A Proposal Schedule may be requested by the Department at any time or may be offered by the Contractor. The Engineer may request that the Contractor prepare a Proposal Schedule to further mitigate any delays that are shown in an accepted TEA or Contract Progress Schedule.

The Contractor shall submit the Proposal Schedule within thirty (30) Calendar Days of a request from the Department.

The Proposal Schedule shall not be considered a Schedule of Record until the logic, durations, narrative, and basis of the Proposal Schedule have been accepted by the Engineer. If the Proposal Schedule took the form of a fragnet, it must be incorporated into the Contract Progress Schedule of Record showing the current progress of all other activities and the impacts/results of the changes made by the Proposal Schedule before the Proposal Schedule is accepted by the Department.

Proposal Schedules shall clearly indicate any proposed acceleration including overtime hours, additional shifts, and the resources that are proposed to be incorporated in the schedule. The Engineer shall have final discretion over the use of overtime hours and additional shifts. Proposal Schedules that contain a cost element shall be submitted with a separate Cost Proposal.

Changes represented in the accepted Proposal Schedules shall be incorporated into the next Contract Progress Schedule. During the review of any Proposal Schedule, all Contract Progress Schedules shall continue to be required every month.

E. Disputes

All schedules shall be submitted, reviewed, dispositioned, and accepted in the timely manner specified herein so as to provide the greatest possible benefit to the execution of this Contract.

The Contractor may dispute a decision by the Engineer by filing a claim notice within seven (7) days after the Contractor's request for additional time has been denied or if the Contractor does not accept the number of days granted in a time extension. The Contractor's claim notice shall include a revised time entitlement analysis that sufficiently explains the basis of the time-related claim. Failure to submit the required time entitlement analysis with the claim notice shall result in denial of the Contractor's claim. A determination on the Contractor's claim shall be in accordance with Subsection 7.16 Claims of Contractor for Compensation. Pending resolution of any dispute, the last schedule accepted by the Engineer will remain the Contract Schedule of Record.

SECTION 722 (Continued)

722.65 Schedule Type D Requirements

This section is to detail the requirements for Type D Schedules and is separate from the requirements listed above. These schedules are intended for a project in which a more formal schedule would not be practical.

Schedules for Type D projects shall be submitted for each work assignment. The Schedule Type D shall be submitted electronically in .XLS and .PDF format and meet the following requirements.

The schedule requirements for work assignments that are anticipated to last three weeks or less shall conform to the requirements for Short-term Construction Schedules below.

Work assignments that are anticipated to last longer than three weeks shall submit a bar chart baseline and provided update schedules upon request of the engineer as required under Bar Chart Schedule below in addition to meeting the Short-term Construction schedule requirements.

A. Bar Chart Schedule

A Bar Chart that shall include the following:

- Work Assignment start date.
- Activities to identify.
- Major work operations broken down to be no longer than 14 days.
 - Procurement of fabricated materials and equipment with long lead times, including time for review and approval of submittals required before procuring and fabricating.
 - The preparation and submission of shop drawings, procedures, and other required submittals, with a planned duration that is to be demonstrated to the Engineer as reasonable.
 - The review and return of shop drawings, procedures, and other required submittals, approved or with comments, the duration of which shall be shown as thirty (30) Calendar Days,
 - Detailed activities to satisfy permit requirements.
 - Subcontractor approvals at fifteen (15) Calendar Days from submittal to response
 - Project Close out activities including a 21-calendar day creation of a punchlist activity and 30 calendar day minimum completion of punchlist activity.
- Interfaces with adjacent work, utility companies, other public agencies, sensitive abutters, and/or any other third-party work affecting the Contract.
- Access Restraints – restrictions on access to areas of the Work
- Traffic work zone set-up and removal, night work and phasing
- Contract Milestones including Full beneficial Use, Substantial Completion and Contractor Field Completion

The Bar Char Schedule shall be provided at the beginning of the project and updated with each work order created for the project.

SECTION 722 (Continued)**B. Short-Term Construction Schedule**

The Contractor shall provide a Short-Term Construction Schedule that details daily work activities, including any multiple shift work that the Contractor intends to conduct, in a spreadsheet format. The daily activities shall directly correspond to the Contract Progress Schedule activities, with a matching reference to the activity identification number in the Contract Progress Schedule and may be at a greater level of detail. See schedule toolkit for suggested format.

The Short-Term Construction Schedule shall be submitted every two weeks. It shall display all work for a thirty-five (35) Calendar Day period consisting of completed work on the assignment for the two week period prior and all planned work for the following three week period. The initial submission shall be provided no later than thirty (30) Calendar Days after NTP or as required by the Engineer.

The Contractor shall be prepared to discuss the Short-Term Construction Schedule, in detail, with the Engineer in order to coordinate field inspection staff requirements, the schedule of work affecting abutters and any corresponding work with affected utilities.

C. Project Spending Report (PSR)

A Projected Spending Report (PSR) shall be prepared and submitted monthly. The PSR shall be for all active work assignments, broken down by work assignment. The PSR shall indicate the monthly spending (cash flow) projection for each month from NTP to Contractor Field Completion (CFC). Each month's actual spending shall be calculated using all CQEs paid during that month. The Projected Spending Report (PSR) shall be depicted in a tabular format and provided in both an .XLS and .PDF

SECTION 722 (Continued)**COMPENSATION****722.80 Method of Measurement****Schedule of Operations (Type A, B and C)**

The project bid documents specify the fixed-price amounts to be paid to the Contractor for the Project Schedule requirements contained herein. Each bidder shall include this fixed price bid item amounts in their bid. Failure to do so may be grounds for the rejection of the bid.

This fixed price amount is for payment purposes only and is separate from what the Department considers to be the Contractor's General Condition costs. If the Contractor deems it necessary to include additional costs to provide all of the requirements of this section, these additional costs shall be included in the Contractor's overall bid price.

All required schedule-related work, including, but not limited to computers, computer software, the planning and coordination with utilities, training, schedule preparation and schedule submittals will be paid for under the fixed price amount.

Twenty percent (20%) of this pay item will be paid upon the Engineer's acceptance of the Contractor's Baseline Schedule, prepared and submitted in accordance with Subsection 722.63.A.

The remaining eighty percent (80%) of this pay item will be paid in equal monthly installments distributed across the Contract Duration from Notice to Proceed (NTP) to Contractor Field Completion (CFC), less the 2 months required for the submittal and review of the Baseline Schedule in accordance with the following formula:

$$\text{Monthly Payment} = \frac{\text{Remaining Fixed Price amount (80\% of the Item Cost.)}}{\text{Contract Duration in whole months} - 2 \text{ months}}$$

The Schedule of Operations pay item will be adjusted to pay for only the actual quantity of schedules that have been submitted in accordance with this section.

Should there be a Time Extension granted to the Contractor, the Engineer may provide an Equitable Adjustment for additional Contract Progress Schedule Updates at intervals directed by the Engineer. The monthly payment will be the basis for this Equitable Adjustment.

Schedule of Operations (Type D)

For projects assigned with Type D schedule requirements, all scheduling work shall be considered incidental to the project with no separate payment under this section.

SECTION 722 (Continued)

722.81 Basis of Payment

The timely and accurate submission of the Baseline Schedule is critical to the Contract and the Department's ability to make informed decisions. Only payments under Item 740 - Engineer's Field Office and Item 748 - Mobilization will be made until the Baseline Schedule is accepted by the Engineer.

All required schedule-related work, including, but not limited to computers, computer software, the planning and coordination with utilities, training, schedule preparation and schedule submittals (including monthly progress schedules, short-term schedules, project spending reports, TEAs, recovery schedules or impacted schedules) shall be included in this work.

No payment for any other pay item will be processed beyond seventy-five (75) Calendar Days from Notice to Proceed (NTP) until the Baseline Schedule is accepted by the Engineer. Until the Engineer's acceptance of the Baseline Schedule, the combined total of all payments made to the Contractor will be limited to an amount no greater than the total price for Item 748 - Mobilization or 3% of the contract price, whichever is less.

All Contract Progress Schedule Updates submitted later than ten (10) Calendar Days after the CQE (Contract Quantity Estimate) completion date, or greater than forty (40) Calendar Days from the Data Date of the previous submission, will be deemed to be no longer useful and will not qualify for payment. The late submission of Impacted schedules, including TEAs, recovery schedules and proposal schedules will result in the forfeiture of the monthly payment for the month in which they were due and subsequent months until the submission is made. Late submission of missed submittals will not result in recovery of the previously forfeited portion of the Schedule of Operations Fixed Price Payment Item.

Failure to submit schedules as and when required may result in the forfeiture of that portion of the Schedule of Operations Fixed Price Payment and/or the withholding of the full or partial CQE payments by the Engineer.

Failure to submit schedules that are acceptable to the Engineer may result in the forfeiture of that portion of the Schedule of Operations Fixed Price Payment and/or the withholding of the full or partial CQE payments by the Engineer.

The Schedule of Operations pay item will be adjusted to pay for only the actual quantity of schedules that have been submitted in accordance with this section.

The Contractor's failure or refusal to comply with the requirements of this Section shall be reasonable evidence that the Contractor is not prosecuting the Work with due diligence and may result in the Engineer withholding of full or partial payments of all work performed.

722.82 Payment Items

- | | | |
|-------|--|----------|
| 722.1 | SCHEDULE OF OPERATIONS (TYPE A) - FIXED PRICE \$ _____ | LUMP SUM |
| 722.2 | SCHEDULE OF OPERATIONS (TYPE B) - FIXED PRICE \$ _____ | LUMP SUM |
| 722.3 | SCHEDULE OF OPERATIONS (TYPE C) - FIXED PRICE \$ _____ | LUMP SUM |

ITEM 106.15**BLEEDER (BRIDGE DECK) PVC****EACH**

The work under this Item shall conform to the relevant provisions of Subsection 901 of the Standard Specifications and the following:

The work shall consist of removal of the existing bridge deck weep drains and installing three new 3/4" inside diameter PVC deck bleeders at each location directed by the Engineer. The work shall be in accordance with the contract drawings.

This work includes removal of old deck bleeders and concrete around the old weep drain deck bleeders, installing new deck weep drains and concrete, furnishing and installing liquid membrane and galvanized screen at all bleeder locations.

An area one foot wide and three-foot-long (minimum), or as directed by the Resident Engineer, shall be marked out around the existing weep drains, and a 1 inch deep saw cut made around the perimeter of the area to be removed. The concrete area shall be chipped out, full depth, in order to remove the old weep drains and any unsound or deteriorated concrete. The Contractor shall prevent any damage to any existing steel reinforcement, curbing, or structural steel during the concrete removal operation. All damage to the existing concrete which is to remain shall be repaired to a condition equal to that existing (prior to concrete removal) at the Contractor's expense.

The Contractor shall create a template and install the new PVC weep drains. It is preferred to have all straight pipe sections for the new weep drains. No bends shall be allowed greater than 22-1/2 degrees and no more than 2 bends shall be allowed per weep drain. It should be clarified that there are three separate weep drains included in the "per unit Each" Item at each location. The new weep drains shall be tied to the existing steel reinforcement on both the upper and lower steel reinforcement mats. Additional steel reinforcement may be installed in order to facilitate this requirement and be paid for under Item 910.1.

The Contractor shall coat the surface of the new concrete and sides of the hot mix asphalt excavation thoroughly with tar mastic. The concrete shall have cured and dried sufficiently prior to starting this operation. After placing the mastic, the Contractor shall place the galvanized screen over the bleeder hole and then dust the placed membrane with Portland cement.

METHOD OF MEASUREMENT

Item 106.15 will be measured for payment by the Each set of three separate weep drains, complete in place.

ITEM 106.15 (Continued)

BASIS OF PAYMENT

Item 106.15 will be paid for at the Contract unit price per Each set of three separate weep drains, which price shall include all labor, materials, equipment, sawcutting, removal of the concrete deck and old weep drains, tar mastic, galvanized mesh, Concrete required for installation of the weep drains, and all incidental costs required to complete the work.

Additional steel reinforcement will be paid for under Item 910.1.

ITEM 106.151

PVC DRAIN PIPE EXTENSIONS

EACH

The work under this item shall conform to the relevant provisions of Subsection 901 of the Standard Specifications and the following:

Work shall consist of reinstalling the missing PVC drain pipe extensions with new PVC drain pipe extensions and in accordance with Section M5.03.7 of Standard Specifications as directed by the Engineer.

The work shall include clamps, grouting, vertical adjustments, and bends as required by the Engineer.

The intent is for the drains to extend below the bottom of the bridge beams and direct water away from any portion of the bridge.

METHOD OF MEASUREMENT

Item 106.151 will be measured for payment per Each PVC drain pipe extension installed, complete in place.

BASIS OF PAYMENT

Item 106.151 will be paid at the contract unit price per Each, which price shall include all materials, labor, equipment, and incidental costs required to complete the work.

<u>ITEM 127.1</u>	<u>REINFORCED CONCRETE EXCAVATION</u>	<u>CUBIC YARD</u>
<u>ITEM 127.4</u>	<u>REINFORCED CONCRETE DECK EXCAVATION</u> <u>(FULL DEPTH)</u>	<u>SQUARE YARD</u>
<u>ITEM 127.41</u>	<u>REINFORCED CONCRETE DECK EXCAVATION</u> <u>(PARTIAL DEPTH)</u>	<u>CUBIC YARD</u>

The work under these Items shall conform to the relevant provisions of Subsections 120 and 482 of the Standard Specifications and the following:

The work shall consist of full and/or partial depth removal and disposal of all disintegrated or otherwise unsatisfactory reinforced concrete from the bridge deck. Any equipment required to erect forms shall be incidental to the relevant items: 127.1, 127.4, and 127.41.

The Contractor will be compensated under either Item 127.1, 127.4 or 127.41 for excavated concrete. In no case will the Contractor be compensated under more than one Item for the same excavated material. Item 127.1 will compensate the Contractor for excavation performed on sidewalks, parapets, bridge curb and when deck excavation is within 3 feet from joint centerline. Items 127.4 and 127.41 will compensate the Contractor for full and partial depth bridge deck excavation.

Prior to excavation, the Contractor shall cover all drainage structures that may be affected by the work. The structures shall remain covered until the new concrete has set and the area has been cleaned.

The Contractor shall take all precautions necessary not to damage that portion of the deck, including reinforcing steel, which is to remain. This includes determining the concrete cover to the steel bars at the edge of each patch prior to excavating concrete.

The edges of all areas where concrete is removed under Items 127.1, 127.4, and 127.41 shall be cut to neat lines by saw cutting or by methods approved by the Engineer, to a depth of 1 inch, and all costs in connection with such work shall be incidental to the pertinent item. Patch areas shall be made rectangular in shape [as much as possible], with horizontal and vertical edges and square corners.

In case the reinforcing bars are exposed, the minimum depth of all cement concrete areas to be excavated shall be one (1) inch below the bottom of the top layer of longitudinal reinforcing steel throughout the entire excavated area. No concrete shall be placed until approval of the Engineer is given.

The cost for the removal of hot mix asphalt and any membrane waterproofing above the area of reinforced concrete excavation will be paid for under Item 129.6 or Item 415.4.

Surface preparation and concrete removal equipment shall be of the following types:

Pneumatic and Power-Driven Chipping Hammers: In no event shall any pneumatic or power hammer weighing in excess of twenty-five (25) pounds be used for the removal of concrete. The Contractor will be restricted to fifteen (15) pound chipping hammers when work involves repairs to slabs of prestressed concrete adjacent deck or box beams, or when removing concrete from below any reinforcing bar.

ITEMS 127.1, 127.4 & 127.41 (Continued)

Abrasive Blasting Equipment: Abrasive blasting equipment shall be capable of removing rust and old concrete from exposed reinforcing steel when deemed necessary by the Engineer.

During the prosecution of this work, the Engineer may reject the use of any method or equipment which causes undue vibration or possible damage to the structure or any part thereof.

Bobcats/Skid Steers will be allowed only to collect debris from the deck surface and will not be allowed to remove concrete from the patch area. All concrete debris shall be removed by hand or by using hand tools. The smaller pieces may be blown out using an oil free compressed air after first being wetted with water to control airborne particulates.

Also, included under these Items are all costs in connection with the cleaning, cutting, and bending of the existing reinforcing steel designated to be retained in the proposed construction. Any existing reinforcing steel damaged or otherwise made unsatisfactory for continued use as a result of the Contractor's operations shall be replaced at the Contractor's expense. All reinforcing steel with active rusting encountered in the excavation shall be thoroughly cleaned by abrasive blasting and coated with a zinc-rich primer conforming to MassDOT Spec. No. M7.04.11 or as directed by the Engineer. Any reinforcing steel that is unsuitable for further use through no fault of the Contractor shall be replaced under Item 910.1. All reinforcing steel that is loose shall be tied tightly together using wire ties. Ties are required at every other intersection of transverse and longitudinal reinforcing.

The exposed area to be patched shall be free of foreign materials. These materials shall be removed by abrasive blasting and by use of oil free compressed air. No grease, dust, rust, or laitance will be allowed to remain on reinforcing steel and exposed concrete surfaces

Temporary Protective Shielding must be used over the roadways during full and partial depth excavation and when, in the opinion of the Engineer, there is the possibility of dislodging concrete from the bottom of the deck.

The Contractor shall take all measures required to protect pedestrian, vehicular traffic, waterway, or railroad below from the construction operations. No debris, tools or incidental equipment of any kind will be permitted to fall into areas where vehicular or pedestrian traffic exists. Any material that accidentally falls into such areas shall be removed immediately.

All excavated materials shall become the property of the Contractor and shall be removed from the job site.

METHOD OF MEASUREMENT

Items 127.1 and 127.41 will be measured for payment respectively by the Cubic Yard of reinforced concrete excavated, removed, and disposed of. Item 127.4 will be measured for payment by the Square Yard of reinforced concrete excavated, removed and disposed of.

ITEMS 127.1, 127.4 & 127.41 (Continued)**BASIS OF PAYMENT**

Items 127.1 and 127.41 will be paid for at the respective Contract unit prices per Cubic Yard, which prices shall include all labor, materials, equipment, sawcutting, cleaning, cutting and bending of the existing reinforcing steel designated to be retained and all incidental costs required to complete the work.

Item 127.4 will be paid for at the Contract unit price per Square Yard, which price shall include all labor, materials, equipment, sawcutting, cleaning, cutting and bending of the existing reinforcing steel designated to be retained and all incidental costs required to complete the work.

New steel reinforcement will be paid for under Item 910.1. The installation of temporary protective shielding will be made under Item 994.1

ITEM 129.6**BRIDGE PAVEMENT EXCAVATION****SQUARE YARD**

The work under this Item shall conform to the relevant provisions of Subsection 120 of the Standard Specifications and the following:

The work shall consist of the removal and satisfactory disposal of all HMA /old pavement and membrane waterproofing from the bridge deck as required by the Engineer.

The Contractor should be required to submit to the Engineer for approval the type of machine that will be used. Any damage to the deck by the Contractors operations shall be repaired at the Contractor's own expense.

METHOD OF MEASUREMENT

Item 129.6 will be measured for payment by the Square Yard of existing HMA pavement excavated, removed, and properly disposed.

BASIS OF PAYMENT

Item 129.6 will be paid for at the Contract unit price per Square Yard, which price shall include all labor, materials, equipment, excavation and disposal HMA pavement, sawcutting, and all incidental costs required to complete the work.

ITEM 180.01 ENVIRONMENTAL HEALTH AND SAFETY PROGRAM LUMP SUM

The work shall consist of ensuring the health and safety of the Contractor's employees and subcontracting personnel, the Engineer, their representatives, the environment, and public welfare from any on-site chemical contamination present in air, soil, water and sediment.

The Contractor shall prepare and implement a site-specific Environmental Health and Safety Plan (EHASP) which has been approved and stamped by a Certified Industrial Hygienist (CIH) and includes the preparer's name and work experience. The EHASP shall include appropriate components required by OSHA Standard 29 CFR 1910.120(b) and the Massachusetts Contingency plan (MCP) 310 CMR 40.0018 and must comply with all applicable state and federal laws, regulations, standards and guidelines, and provide a degree of protection and training appropriate for implementation on the project. The EHASP shall be a dynamic document with provision for change to reflect new information, new practices or procedures, changing site environmental conditions or other situations which may affect site workers and the public. The EHASP shall be developed and implemented independently from the standard construction HASP required to work on all MassDOT construction projects.

Health and safety procedures provided by the Contractor shall comply with all the appropriate regulations that address employee working conditions, including but not limited to standards established by OSHA and National Institute for Occupational Safety and Health (NIOSH). Equipment used for the purpose of health and safety shall be approved by and meet pertinent standards and specifications of the appropriate regulatory agencies.

A copy of the most up-to-date version of the EHASP shall be maintained on-site at all times by the Contractor. The on-site copy shall contain the signature of the Engineer and each on-site employee of the MassDOT, Contractor, and Subcontractors involved with on-site activities. The employee's signature on the EHASP shall be deemed prima facie evidence that the employee has read and understands the plan. Updated copies of signature sheets shall be submitted to the Engineer.

The EHASP shall specify a Contractor Site Safety and Health Officer responsible for implementation of the EHASP and to oversee all construction activities, including handling, storage, sampling and transport, which require contact with or exposure to potentially hazardous materials.

The level of protection, required to ensure the health and safety of on-site personnel will be stipulated in the EHASP. The Site Safety and Health Officer shall implement the EHASP based on changing site and weather conditions, type of operation or activity, chemical compounds identified on-site, concentration of the chemicals, air monitoring data, physical state of the hazardous materials, potential duration of exposure to hazardous materials, dexterity required to perform work, decontamination procedures, necessary personnel and type of equipment to be utilized.

ITEM 180.01 (Continued)

During implementation of the EHASP, a daily log shall be kept by the Site Safety and Health Officer and a copy shall be provided weekly to the Engineer. This log shall be used to record a description of the weather conditions, levels of personal protection being employed, screening data and any other information relevant to on-site environmental safety conditions. The Site Safety and Health Officer shall sign and date the daily log.

METHOD OF MEASUREMENT AND BASIS OF PAYMENT

Preparation and implementation of the Environmental Health and Safety Program, including the monitoring, protection and storage of all contaminated materials, as well as subsequent modifications to the EHASP, will be measured and paid for at the Lump Sum Bid Price.

Payment of 50% of the Environmental Health and Safety Program contract price will be made upon the initial acceptance of the EHASP by the Engineer. Payment of the remaining 50% of the Environmental Health and Safety Program contract price will be made upon completion of the work. The bid price shall include preparation and implementation of the EHASP as well as the cost for its enforcement by the Site Safety and Health Officer along with any necessary revisions and updates. The work of implementing the Environmental Health and Safety Program includes work involving, but not limited to, the monitoring, protection, and storage of all contaminated materials.

ITEM 180.02 **PERSONAL PROTECTION LEVEL C UPGRADE** **HOUR**

The work shall consist of providing appropriate personal protective equipment (PPE) for all personnel in an area either containing or suspected of containing a hazardous environment.

Contingencies for upgrading the level of protection for on-site workers will be identified in the EHASP and the Contractor shall have the capability to implement the personal protection upgrade in a timely manner. The protective equipment and its use shall be in compliance with the EHASP and all appropriate regulations and/or standards for employee working conditions.

Personal Protection Level C Upgrade will be measured and paid only upon upgrade to Level C and will be at the contract unit price, per hour, per worker, required in Level C personal protection. No payment will be made to the Contractor to provide Level D PPE.

ITEM 180.03**LICENSED SITE PROFESSIONAL SERVICES****HOUR**

Within limited areas of the project site, soils, sediments and/or groundwater may be contaminated. A Licensed Site Professional (LSP) shall be required to provide the services necessary to comply with the requirements of the MCP. These services may include sampling, analysis and characterization of potentially contaminated media, preparation of Immediate Response Action (IRA) Plans, Utility-Related Abatement Measure (URAM) and Release Abatement Measure (RAM) Plans, Imminent Hazard Evaluations, status reports, transmittal forms, release notification forms, risk assessments, completion statements, and related documents required pursuant to the Massachusetts Contingency Plan (MCP). LSP hours related to the characterization and disposal of contaminated soil and/or sediment are incidental to the disposal items. An estimate of LSP services to be provided shall be submitted to the Engineer for approval before any LSP activity begins.

The name and qualifications of the LSP and all environmental technicians to be assigned to the project shall be submitted to the Engineer for approval at least four weeks prior to initial site activities. The LSP shall have a current, valid license issued by the Massachusetts Board of Registration of Hazardous Waste Site Cleanup Professionals. The LSP shall have significant experience in the oversight of MCP activities at active construction sites. Qualification packages for the LSP and each technician shall include a resume, all recent work assignments with responsibilities identified (previous 5 years), and applicable training and certifications. A list of all Notices of Noncompliance, Notice of Audit Findings and Enforcement Orders issued by the DEP shall be submitted for all work assignments listed for the LSP and environmental technicians.

The LSP shall evaluate soil and/or sediment with discoloration, odor, and presence of petroleum liquid or sheening on the groundwater surface, or any abnormal gas or materials in the ground which are known or suspected to be oil or hazardous materials. Excavated soil and sediment which is suspected of petroleum contamination shall be field screened using the jar headspace procedures according to established DEP Guidance. All field screening equipment must be pre-approved by the Engineer. The LSP shall ensure proper on site calibration of all field screening instrumentation.

The Engineer shall be contacted immediately when observations or any field screening results verify contamination requiring further analysis, and/or enhanced management of suspect soil and/or sediment. Any enhanced management of contaminated soil to ensure proper stockpiling and storage is incidental to the LSP Services item. The LSP shall adequately characterize subsurface conditions prior to backfill in areas where contaminated material has been excavated. The Engineer shall approve the locations of the testing sites prior to the sampling.

ITEM 180.03 (Continued)

Contaminated soil, sediment and/or groundwater shall be handled in accordance with all applicable state and federal statutes, regulations and policies. The LSP shall adequately characterize contaminated media for comparison to the requirements of the MCP.

The Contractor and the LSP shall be aware of the reporting requirements for releases of oil and/or other hazardous material (OHM) as set forth in federal and state laws and regulations, and shall both be held responsible for performing the work in accordance with all applicable Federal and State laws and regulations. The LSP shall maintain written records in a clear and concise format which tracks the excavation, stockpiling, analysis and reuse/disposal of all suspect contaminated soils, sediments and groundwater. These records shall be up-to-date and available to the Engineer on a bi-weekly basis. The LSP shall review and summarize the laboratory data from any analyses performed on contaminated media. A report shall be delivered to the Engineer outlining the material sampling methods, laboratory analysis results and proposed course of action. The laboratory report together with Chain of Custody forms for all analytical results shall be submitted to the Engineer within 14 days after completion of such analyses.

The LSP and Contractor shall be held responsible for the submission of all MCP-related documents to the Engineer at least 14 days in advance of any timeframe specified in the MCP and for the timely submission of data and tracking information as noted within this Item. All documents prepared under this Item must be reviewed and signed by the approved LSP. The Contractor and LSP shall be responsible for all fines, penalties and enforcement requirements imposed by applicable regulatory agencies for failure to meet regulatory and contract timeframes. No compensation will be provided for such fines, penalties and enforcement actions.

The Contractor and the LSP shall be aware of the reporting requirements for releases of oil and/or other hazardous material (OHM) as set forth in federal and state laws and regulations, and shall both be held responsible for performing the work in accordance with all applicable Federal and State laws and regulations.

If the Contractor causes a release of OHM, the Contractor shall be responsible for assessing and remediating the release in accordance with all pertinent State and Federal regulations, including securing the services of a LSP, at his own expense.

The LSP shall coordinate all activities involving both MassDOT and the DEP through the Engineer. Any notification of release shall be approved by the Department before submittal to the DEP, except if an imminent hazard condition exists as defined in 309 CMR 4.03(4)(b).

ITEM 180.03 (Continued)**LABORATORY TESTING IN SUPPORT OF LSP SERVICES**

Laboratory testing provides for analytical testing in support of LSP services related to maintaining MCP compliance, such as delineating the extent and type of contamination present. Sampling and testing for disposal purposes are not included.

In order to maintain compliance with the MCP or other regulatory requirements, the LSP shall request approval from the Engineer to obtain samples from various locations and depths within the project area and to perform laboratory analyses on those samples. The samples shall be delivered to a DEP-certified laboratory using proper chain-of-custody documentation for analyses which, depending upon site conditions and suspected and/or identified contaminants of concern, may include, but are not limited to, metals, polychlorinated biphenyls (PCBs), volatile organic compounds (VOCs), semivolatile organic compounds (SVOCs), pesticides, polycyclic aromatic hydrocarbons (PAHs), extractable petroleum hydrocarbons (EPHs) and volatile petroleum hydrocarbons (VPHs). Subsequent testing, depending upon initial results, may be required for Toxicity Characteristic Leaching Procedure (TCLP) analyses (EPA Method 1311) for metals.

METHOD OF MEASUREMENT AND BASIS OF PAYMENT

LSP Services for work under this item will be measured per person, per hour of service provided by LSP, Environmental Technicians and other approved personnel. Travel time shall not be included in the billable hours. LSP hours related to soil/sediment disposal (disposal characterization, landfill acceptance, disposal package preparation, etc.) shall be incidental to disposal items.

The quantity and type of laboratory tests must be approved by the Engineer beforehand. The contractor will be reimbursed upon satisfactory written evidence of payment. The contractor may be required to obtain cost estimates from three DEP certified laboratories for the Engineer to choose the service provider. Laboratory testing related to soil/sediment disposal (disposal characterization, landfill acceptance, disposal package preparation, etc.) shall be incidental to disposal items.

LSP Services will be paid at the Contractor bid price for each hour, or fraction thereof, spent to perform the work as described above. The bid price shall be a blended rate that includes the cost of the LSP, environmental technicians and other personnel, the performance of all work tasks and field screening, including required equipment, materials and instrumentation, and production of all documentation described above. All requests for payment must be accompanied by the following information: the names of the personnel associated with the work charged under LSP Services, dates and hours worked, work conducted, including, where appropriate, locations as identified on the construction plans, and a copy of the field diary for the dates submitted.

ITEM 180.03 (Continued)

Laboratory Testing will be reimbursed upon receipt of paid invoices for testing approved by the Engineer.

This item is for LSP work for compliance with the MCP and Department Policies. LSP hours and any laboratory testing related to off-site disposal of excess soil and sediment is incidental to Items 181.11-181.14 (including, but not limited to, disposal characterization, disposal package preparation, landfill acceptance, shipment paperwork preparation, field screening, and tracking).

<u>ITEM 181.11</u>	<u>DISPOSAL OF UNREGULATED SOIL</u>	<u>TON</u>
<u>ITEM 181.12</u>	<u>DISPOSAL OF REGULATED SOIL - IN-STATE FACILITY</u>	<u>TON</u>
<u>ITEM 181.13</u>	<u>DISPOSAL OF REGULATED SOIL - OUT-OF-STATE FACILITY</u>	<u>TON</u>
<u>ITEM 181.14</u>	<u>DISPOSAL OF HAZARDOUS WASTE</u>	<u>TON</u>

The work under these Items shall include the transportation and disposal of contaminated material excavated, or excavated and stockpiled. It shall also include the cost of any additional laboratory analyses required by a particular disposal facility beyond the standard disposal test set.

Excavation of existing subsurface materials may include the excavation of contaminated soils. The Contractor shall be responsible for the proper coordination of characterization, transport and disposal, recycling or reuse of contaminated soils. Disposal, recycling or reuse will be referred to as “disposal” for the purposes of this specification. However, regardless of the use of the term herein, there will be no compensation under these items for reuse within the project limits. The Contractor will be responsible for coordinating the activities necessary for characterization, transport and disposal of contaminated soils. Such coordination will include the Engineer and his/her designee overseeing management of contaminated materials. Contaminated soils must be disposed of in a manner appropriate for the soil classification as described below and in accordance with the applicable laws of local, state and federal authorities. The Contractor shall be responsible for identifying disposal facility (ies) licensed to accept the class of contaminated soils to be managed and assure that the facility can accept the anticipated volume of soil contemplated by the project. The Contractor shall be responsible for hiring a Licensed Site Professional (LSP) and all ancillary professional services including laboratories as needed for this work. The Contractor will be responsible for obtaining all permits, approvals, manifests, waste profiles, Bills of Lading, etc. subject to the approval of the Engineer prior to the removal of the contaminated soil from the site. The Contractor and LSP shall prepare and submit to the Engineer for approval all documents required under the Massachusetts Contingency Plan (MCP) and related laws and environmental regulations to conduct characterization, transport, and disposal of contaminated materials.

CLASSES OF CONTAMINATED SOILS

The Contractor and its LSP shall determine if soil excavated or soil to be excavated is unregulated soil or contaminated soil as defined in this section. Such materials shall be given a designation for purposes of reuse or disposal based on the criteria of the MCP. Soils and sediments which are not suitable for reuse will be given a designation for purposes of off-site disposal based on the characterization data and disposal facility license requirements. The Classes of Contaminated Soils are defined as follows:

ITEMS 181.11 through 181.14 (Continued)

UNREGULATED SOIL consists of soil, fill and dredged material with measured levels of oil and hazardous material (OHM) contamination at concentrations below the applicable Reportable Concentrations (RCs) presented in the MCP. Unregulated soil consists of material which may be reused (or otherwise disposed) as fill within the Commonwealth of Massachusetts subject to the non-degradation criteria of the MCP (310 CMR 40.0032(3), in a restricted manner, such that they are sent to a location with equal or higher concentrations of similar contaminants. Disposal areas include licensed disposal facilities, approved industrial settings in areas which will be capped or covered with pavement or loamed and seeded, and for purposes of this project should be reused as fill within the project site construction corridor whenever possible. The material cannot be placed in residential and/or environmentally sensitive (e.g. wetlands) areas. Under no circumstances shall contaminated soils be placed in an uncontaminated or less contaminated area (including the area above the groundwater table if this area shows no sign of contamination).

The Contractor shall submit to MassDOT the proposed disposal location for unregulated soils for approval. If such a disposal location is not a licensed disposal facility, the Contractor shall submit to the Engineer analytical data to characterize the disposal area sufficiently to verify that the unregulated material generated within the MassDOT construction project limits is equal to or less than the contaminant levels at the disposal site and meets the non-degradation requirements of the MCP. In addition, the Contractor shall provide written confirmation from the owner of the proposed disposal location that they have been provided with the analytical data for both the materials to be disposed as well as the disposal site characterization and that s/he agrees to accept this material. A Material Shipping Record or Bill of Lading, as appropriate, shall be used to track the off-site disposal of unregulated soil and a copy, signed by the disposal facility or property owner, shall be provided to the Engineer in order to document legal disposal of the unregulated material.

The cost of on-site disposal of unregulated soil within the project area will be considered incidental to the item of work to which it pertains.

ITEMS 181.11 through 181.14 (Continued)

REGULATED SOIL consists of materials containing measurable levels of OHM that are equal to or exceed the applicable Reportable Concentrations for the site as defined by the MCP, 310 CMR 40.0000. Regulated soil which meets the MCP reuse criteria of the applicable soil/groundwater category for this project area may be reused on site provided that it meets the appropriate geotechnical criteria established by the Engineer. Regulated Soil may be reused (as daily or intermediate cover or pre-cap contouring material) or disposed (as buried waste) at lined landfills within the Commonwealth of Massachusetts or at an unlined landfill that is approved by the Massachusetts Department of Environmental Protection (DEP) for accepting such material, in accordance with DEP Policy #COMM-97-001, or at a similar out-of-state facility. It should be noted that soils which exceed the levels and criteria for disposal at in-state landfills, as outlined in COMM-97-001, may be shipped to an in-state landfill, but require approval from the DEP Division of Solid Waste Management and receiving facility. An additional management alternative for this material is recycling into asphalt. Regulated Soils may also be recycled at a DEP approved recycling facility possessing a Class A recycling permit subject to acceptance by the facility and compliance with DEP Policy #BWSC-94-400. Regulated Soil removed from the site for disposal or treatment must be removed via an LSP approved Bill of Lading, Manifest or applicable material tracking form. This type of facility shall be approved/permitted by the State in which it operates to accept the class of contaminated soil in accordance with all applicable local, state and federal regulations.

HAZARDOUS WASTE consists of materials which must be disposed of at a facility permitted and operated in full compliance with Federal Regulation 40 CFR 260-265, Massachusetts Regulation 310 CMR 30.000, Toxic Substances Control Act (TSCA) regulations, or the equivalent regulations of other states, and all other applicable local, state, and federal regulations. All excavated materials classified as hazardous waste shall be disposed of at an out-of-state permitted facility. This facility shall be a RCRA hazardous waste or TSCA facility, or RCRA hazardous waste incinerator. This type of facility shall be approved/permitted by the State in which it operates to accept hazardous waste in accordance with all applicable local, state and federal regulations and shall be permitted to accept all contamination which may be present in the soil excavate. The Contractor shall ensure that, when needed, the facility can accept TSCA waste materials i.e. polychlorinated biphenyls (PCBs). Hazardous waste must be removed from the site for disposal or treatment via an LSP approved Manifest.

MONITORING/SAMPLING/TESTING REQUIREMENTS

The Contractor shall be responsible for monitoring, sampling and testing during and following excavation of contaminated soils to determine the specific class of contaminated material. Monitoring, sampling and testing frequency and techniques should be performed in accordance with Item 180.03 – LSP Services. Additional sampling and analysis may be necessary to meet the requirements of the disposal facility license. The cost of such additional sampling and analysis shall be included in the bid cost for the applicable disposal items. The Contractor shall obtain sufficient information to demonstrate that the contaminated soil meets the disposal criteria set by the receiving facility that will accept the material.

ITEMS 181.11 through 181.14 (Continued)

No excavated material will be permanently placed on-site or removed for off-site disposal until the results of chemical analyses have been received and the materials have been properly classified. The Contractor shall submit to the Engineer results of field and laboratory chemical analyses tests within seven days after their completion, accompanied by the classification of the material determined by the Contractor, and the intended disposition of the material. The Contractor shall submit to the Engineer for review all plans and documents relevant to LSP services, including but not limited to, all documents that must be submitted to the DEP.

WASTE TRACKING:

Copies of the fully executed Weight Slips/Bills of Lading/ Manifests/Material Shipping Records or other material tracking form received by the Contractor from each disposal facility and for each load disposed of at that facility, shall be submitted to Engineer and the Contractor's LSP within three days of receipt by the Contractor. The Contractor is responsible for preparing and submitting such documents for review and signature by the LSP or other appropriate person with signatory authority, three days in advance of transporting soil off-site. The Contractor shall furnish a form attached to each manifest or other material tracking form for all material removed off-site, certifying that the material was delivered to the site approved for the class of material. If the proposed disposition of the material is for reuse within the project construction corridor, the Contractor shall cooperate with MassDOT to obtain a suitable representative sample(s) of the material to establish its structural characteristics in order to meet the applicable structural requirements as fill for the project.

All material transported off-site shall be loaded by the Contractor into properly licensed and permitted vehicles and transported directly to the selected disposal or recycling facility and be accompanied by the applicable shipping paper. At a minimum, truck bodies must be structurally sound with sealed tail gates, and trucks shall be lined and loads covered with a liner, which shall be placed to form a continuous waterproof tarpaulin to protect the load from wind and rain.

DECONTAMINATION OF EQUIPMENT

Tools and equipment which are to be taken from and reused off site shall be decontaminated in accordance with applicable local, state and federal regulations. This requirement shall include, but not be limited to, all tools, heavy machinery and excavating and hauling equipment used during excavation, stockpiling and handling of contaminated material. Decontamination of equipment is considered incidental to the applicable excavation item.

ITEMS 181.11 through 181.14 (Continued)**REGULATORY REQUIREMENTS**

The Contractor shall be responsible for adhering to regulations, specifications and recognized standard practices related to contaminated material handling during excavation and disposal activities. MassDOT shall not be responsible at any time for the Contractor's violation of pertinent State or Federal regulations or endangerment of laborers and others. The Contractor shall comply with all rules, regulations, laws, permits and ordinances of all authorities having jurisdiction including, but not limited to, Massachusetts DEP, the U.S. Environmental Protection Agency (EPA), Federal Department of Transportation (DOT), Massachusetts Water Resources Authority (MWRA), the Commonwealth of Massachusetts and other applicable local, state and federal agencies governing the disposal of contaminated soils.

All labor, materials, equipment and services necessary to make the work comply with such regulations shall be provided by the Contractor without additional cost to MassDOT. Whenever there is a conflict or overlap within the regulations, the most stringent provisions shall apply. The Contractor shall reimburse MassDOT for all costs it incurs, including penalties and/or for fines, as a result of the Contractor's failure to adhere to the regulations, specifications, recognized standard practices, etc., that relate to contaminated material handling, transportation and disposal.

SUBMITTALS**I. Summary of Sampling Results, Classification of Material and Proposed Disposal Option.**

The following information, presented in tabular format, must be submitted to the Engineer for review and approval prior to any reuse on-site or disposal off-site. This requirement is on-going throughout the project duration. At least two weeks prior to the start of any excavation activity, the Contractor shall submit a tracking template to be used to present the information as stipulated below. Excavation will not begin until the format is acceptable to MassDOT.

Characterization Reports will be submitted for all soil, sediment, debris and groundwater characterized through the sampling and analysis program. Each report will include a site plan which identifies the sampling locations represented in the Report. The Construction Plan sheets may be used as a baseplan to record this information.

The Sampling Results will be presented in tabular format. Each sample will be identified by appropriate identification matching the sample identification shown on the Chain of Custody Record. The sample must also be identified by location (e.g. grid number or stockpile number). For each sample, the following information must be listed: the classification (unregulated, regulated, etc.), proposed disposal option for the stockpile or unit of material represented, and, all analytical results.

ITEMS 181.11 through 181.14 (Continued)

Each Characterization Report will include the laboratory analytical report and Chain of Custody Record for the samples included in the Report.

II. Stockpiling, Transport, and Disposal.

At least two weeks prior to the start of any excavation activity, the Contractor shall submit, in writing, the following for review and shall not begin excavation activity until the entire submittal is acceptable to MassDOT.

Excavation and Stockpiling Protocol:

Provide a written description of the management protocols for performing excavation and stockpiling and/or direct loading for transport, referencing the locations and methods of excavating and stockpiling excavated material.

Disposal and Recycling Facilities:

1. Provide the name, address, applicable licenses and approved waste profile for disposal and/or recycling location(s) where contaminated soil will be disposed. Present information substantiating the suitability of proposed sites to receive classifications of materials intended to be disposed there, including the ability of the facility to accept anticipated volumes of material.
2. Provide a summary of the history of compliance actions for each disposal/recycling facility proposed to be used by the Contractor. The compliance history shall include a comprehensive list of any state or federal citations, notices of non-compliance, consent decrees or violations relative to the management of waste (including remediation waste) at the facility. Material should not be sent to facilities which are actively considered by the DEP, USEPA or other responsible agency to be in violation of federal, state or local hazardous waste or hazardous material regulations. MassDOT reserves the right to reject any facility on the basis of poor compliance history.

Transportation:

The name, address, applicable license and insurance certificates of the licensed hauler(s) and equipment and handling methods to be used in excavation, segregation, transport, disposal or recycling.

III. Material Tracking and Analytical Documentation for Reuse/Disposal.

The following documents are required for all excavation, reuse and disposal operations and shall be in the format described. At least two weeks prior to the start of any excavation or demolition activity, the Contractor shall submit the tracking templates required to present the information as stipulated below. Excavation or demolition will not begin until the format is acceptable to MassDOT.

ITEMS 181.11 through 181.14 (Continued)

All soils, sediments and demolition debris must be tracked from the point of excavation to stockpiling to onsite treatment/processing operations to off-site disposal or onsite reuse as applicable.

Demolition Debris:

Demolition debris must be tracked if the debris is stockpiled at a location other than the point of origin or if treatment or material processing is conducted. Identification of locations will be based on the station-offset of the location. The tracking table will identify date and point of generation, any field screening such as PID or dust monitoring, visual observations/comments, quantity, and stockpile ID/processing operation location. For each unit of material tracked, the table will also track reuse of the material on-site, providing reuse date, location of reuse as defined by start and end station, width of reuse location by offset, the fill elevation range, quantity, and finish grade for said location. For demolition debris which is not reused on site, the table will also track disposal of the material as defined by disposal date, quantity and disposal facility. The table must provide a reference to any analytical data generated for the material.

Soil/Sediment:

Soil excavation will be identified based on the station-offset of the excavation location limits. The tracking table will identify date and point of generation, any field screening such as PID or dust monitoring, visual observations, quantity, and stockpile number/location. For each unit of material tracked, the table will also track reuse of the material on-site and disposal of the material off-site using the same categories identified for demolition debris above.

METHOD OF MEASUREMENT AND BASIS OF PAYMENT

Disposal of contaminated soil shall be measured for payment by the Ton of actual and verified weight of contaminated materials removed and disposed of. The quantities will be determined only by weight slips issued by and signed by the disposal facility. The most cost-effective, legal disposal method shall be used. The work of the LSP for disposal under all of these items shall be incidental to the work with no additional compensation.

ITEM 181.11 Measurement for Disposal of Unregulated Soil shall be under the Contract Unit Price by the weight, in tons, of contaminated materials removed from the site and transported to and disposed of at an approved location or licensed facility, and includes any and all costs for approvals, permits, fees and taxes, additional testing/characterization required by the facility beyond the standard disposal test set, decontamination procedures, transportation and disposal.

ITEM 181.12 Measurement for Disposal of Regulated Soil – In-State Facility shall be under the Contract Unit Price by the weight in tons of contaminated materials removed from the site and transported to and disposed of at an approved in-state facility, and includes any and all costs for approvals, permits, fees and taxes, testing/characterization required by the facility beyond the standard disposal test set, decontamination procedures, transportation and disposal.

ITEMS 181.11 through 181.14 (Continued)

ITEM 181.13 Measurement for Disposal of Regulated Soil - Out-of-State Facility shall be under the Contract Unit Price by the weight in tons of contaminated materials removed from the site and transported to and disposed of at an approved out-of-state facility, and includes any and all costs for approvals, permits, fees and taxes, testing/characterization required by the facility beyond the standard disposal test set, decontamination procedures, transportation and disposal.

ITEM 181.14 Measurement for Disposal of Hazardous Waste shall be under the Contract Unit Price by the weight in tons of hazardous waste removed from the site and transported to and disposed of at the licensed hazardous waste facility, and includes any and all costs for approvals, permits, fees and taxes, testing/characterization required by the facility beyond the standard disposal test set, decontamination procedures, transportation and disposal.

ITEM 184.1 **DISPOSAL OF TREATED WOOD PRODUCTS** **TON**
(Rev 08/09/2016)

Work under this item shall include the transportation and disposal of all treated existing wood product as directed by the Engineer.

The timber components of the existing structure are suspected to be treated with creosote, pentachlorophenol and/or CCA. This item shall include all costs for sampling, laboratory testing, loading, transportation and disposal of the treated wood. The Contractor is required to submit disposal manifests to the Engineer prior to the completion of the project. All aspects of this Item are to be completed in accordance with state and federal regulations.

Compensation

Measurement and payment will be by the weight, in tons, of treated timber transported and accepted at a licensed facility. The work shall be considered full compensation for all labor, tools, equipment, materials, testing, loading, transportation, approvals, and permits necessary for the completion of the work.

ITEM 221.1

FRAME AND COVER - SECURED

EACH

The work under this Item shall conform to the relevant provisions of Subsections 201, 220 and the following:

The work to be done under this Item consists of the furnishing and delivering Frame and Cover – Secured to the site as shown on the Plans, and as directed by the Engineer.

Frame and Cover - Secured assemblies shall consist of covers and frames that conform to the nominal size, weight, material and load-carrying requirements in MassDOT Construction Standard Details E 202.6.0, E 202.7.0 and E 202.8.0, and are on the relevant MassDOT Qualified Construction Materials list. Some dimensions of secured manhole covers and frames may vary slightly from those shown on the standard details to account for necessary fastening components. The Contractor shall submit shop drawings of all drainage castings for approval prior to ordering.

Covers and frames shall be held securely together by bolting to threaded holes in the frame or to nuts or tumbler devices secured by the frame, by use of hooks attached to the cover or by any other means approved by MassDOT, to prevent being dislodged under traffic loading. Gaskets and other sealing devices will not be allowed.

Method of Measurement

Item 221.1 will be measured per EACH Frame and Cover – Secured furnished and delivered to the site.

Basis of Payment

Item 221.1 will be paid for at the contract unit price EACH Frame and Cover – Secured furnished and delivered.

ITEM 280.2

CLEANING PAVED WATERWAYS

SQUARE YARD

The work under this item shall conform to the relevant provision of Subsection 120 of the Standard Specifications and the following:

The work shall consist of cleaning all existing paved waterways and aprons within the project limits as directed by the Engineer.

All dirt and debris shall be removed from the waterway surface. Weeds, grass and other growth along the edges of the waterway or in cracks in the waterway shall be completely removed. The Contractor shall dispose of material removed from waterways in accordance with subsection 120 Excavation.

METHOD OF MEASUREMENT

Item 280.2 will be measured for payment by the Square Yard, with the measurement made prior to cleaning, and including only that area of the waterway surface that is covered by existing debris. No additional allowance or adjustment of the area measured will be made for any variable depth of the material removed.

BASIS OF PAYMENT

Item 280.2 will be paid for at the Contract unit price per Square Yard, which price shall include all labor, materials, equipment, and incidental costs required to complete the work.

ITEM 402.14 PAVEMENT MILLING MULCH FOR SHOULDERS TON

The work under this item shall conform to the relevant provisions of Section 400 and Subsection 769 of the Standard Specifications and the following:

The work consists of placing pavement millings in low spots and grading and compacting the pavement millings to provide lateral support at the edge of pavement in country drainage areas without berm, edging, or curb. Low areas along the edge of pavement shall be filled with pavement millings to a level flush with and graded to the same cross slope as the adjacent HMA shoulder. The existing unpaved shoulder shall be prepared for pavement milling mulch as necessary as determined by the Engineer. Milling mulch shall be graded and compacted to a minimum width determined by the Engineer.

Materials

Pavement milling mulch shall conform to Materials Specification M1.10.0.

METHOD OF MEASUREMENT

Item 402.14 will be measured for payment by the Ton, complete in place.

BASIS OF PAYMENT

Item 402.14 will be paid for at the Contract unit price per Ton, which price shall include all labor, materials, equipment, excavation, grading and leveling, compacting and incidental costs required to complete the work.

**ITEM 457.2 SUPERPAVE WATERPROOFING SURFACE TON
COURSE - 12.5 (SSC-W-12.5)**

Work under this item shall conform to the relevant provisions of Subsection 457 Superpave Waterproofing Surface Course contained herein Document 00714.

**ITEM 458.2 SUPERPAVE HIGH PERFORMANCE SURFACE TON
COURSE (HP-12.5)**

Work under this Item shall conform to the relevant provisions of SUBSECTION 458 SUPERPAVE HIGH PERFORMANCE SURFACE COURSE contained herein Document 00712.

ITEM 482.31**SAWING AND SEALING JOINTS IN
ASPHALT PAVEMENT AT BRIDGES****FOOT**

The work to be done under this Item consists of making a sealed kerf across the full width of the finished asphalt pavement at bridge abutments where called for on the Plans. The shape, width, and depth of the kerf shall be as shown in the Construction Details.

Prior to the start of the asphalt pavement operation, the Contractor shall place a mark on each curb or barrier on either side of the paved roadway. These marks shall be aligned with the actual end of the bridge deck and shall be placed so that they will not be covered or otherwise obscured by the asphalt pavement.

After the completion of the paving operation, the Contractor shall snap a straight chalk line on the pavement between these two marks. The Contractor shall then saw cut the pavement along this line to the depth, width and shape as shown on the Plans. The equipment shall be approved by the Engineer prior to commencing work.

After completing the saw cutting, the Contractor shall clean the saw groove of any dust and debris with an oil free air blast. If the groove was wet sawn, the groove shall be cleaned with a water blast to remove any remaining slurry and debris, vacuumed with a Wet-or-Dry vacuum to remove any standing water, and then dried with an air blast from a Hot-Air-Lance.

Once the groove is clean and dry, the Contractor shall fill it completely with a hot-applied bituminous crack sealer meeting the requirements of M3.05.4 in accordance with the manufacturer's application instructions and restrictions regarding ambient and material temperatures. The crack sealer shall be thoroughly cured prior to opening the road to traffic. To reduce tackiness, only boiler slag aggregate (black beauty) shall be scattered over the sealer when required by the Engineer. Conventional sand shall not be used for this purpose.

METHOD OF MEASUREMENT

Item 482.31 will be measured for payment by the Foot, of the actual number of feet of kerf sawed and sealed in the asphalt pavement surface, complete in place.

BASIS OF PAYMENT

Item 482.31 will be paid for at the Contract unit price per Foot, which price shall include all labor, materials, equipment, and all incidental costs required to complete the work.

ITEM 504.2

GRANITE CURB TYPE VA4 – SPLAYED END

EACH

The work under this item shall conform to the relevant provisions of Section 500 of the Standard Specifications and the following:

The work shall include furnishing and installing granite splayed end transition curb (straight or curved) where vertical granite curb or concrete barrier wall transitions to granite sloped edging or to HMA curb. Locations shall be shown on the Contract Sketches.

Materials

Material shall conform to Section M9.04.0. Dimensions and configuration, including radius of curvature, shall conform to the Contract Sketches.

The splayed end curb shall consist of a single granite curb stone, with a tapered wedge cut from the top front edge, on the left or right as appropriate. The tapered wedge shall present a neat and uniform appearance with the overall stone and shall be formed using the same method (sawcut or split) used to shape the top surface of the original stone. Modifying a common curb stone by hand cutting or chipping will not be accepted.

No distinction will be made between curb stones that transition to the left or to the right. No distinction will be made for curved splayed ends of different radii.

METHOD OF MEASUREMENT

Item 504.2 will be measured for payment by the unit each, complete in place.

BASIS OF PAYMENT

Item 504.2 will be paid for at the contract unit price per Each, which price shall include all labor, materials, equipment and incidental costs required to complete the work.

<u>ITEM 626.321</u>	<u>MAINTENANCE OF STEEL THRIE BEAM BRIDGE RAIL RETROFIT</u>	<u>LUMP SUM</u>
----------------------------	--	------------------------

The work under this Item shall conform to the relevant provisions of Subsection 601 and the following:

The work to be performed under this Item consists of inspecting and tightening loose bolts securing thrie beam bridge rail to the parapet and inspecting for damaged block outs between the bridge rail and parapet of bridges W-21-045, W-21-046, and W-21-047.

The Contractor and Engineer shall inspect all existing thrie beam retrofit bolts for tightness and damage. The replacement of missing or damage bolts shall be incidental to this Item.

Bolts in the expansion section shall be tightened so that full contact with the beam element is achieved, but not so tight as to impede movement due to expansion.

BASIS OF PAYMENT

Item 626.321 will be paid for at the contract unit price per lump sum, which price shall include all labor, materials, equipment and incidental costs to complete the work. No additional compensation shall be provided for the replacement of damaged or missing bolts.

The replacement of damaged block outs will be paid for under Item 626.322.

<u>ITEM 626.322</u>	<u>BRIDGE RAIL RETROFIT BLOCK OUT REPLACEMENT</u>	<u>EACH</u>
----------------------------	--	--------------------

The work under this Item shall conform to the relevant provisions of Subsection 601 of the Standard Specifications and the following:

The work shall consist of replacing damaged bridge rail block outs on bridges W-21-045, W-21-046, and W-21-047. Inspection of existing block outs shall be performed under Item 626.321.

The Contractor and Engineer shall inspect all existing thrie beam retrofit block outs for damage and replace all damaged block outs.

METHOD OF MEASUREMENT

Item 626.322 will be measured for payment by Each, retrofit block out replaced.

BASIS OF PAYMENT

Item 626.322 will be paid for at the contract unit price per Each, which price shall include removing of the damaged block out, installation of the new block out, replacement of any damaged or missing hardware, labor, equipment and incidental costs required to complete the work.

Disposal of the damage block out will be paid for under Item 184.1.

ITEM 740. ENGINEER'S FIELD OFFICE AND EQUIPMENT (TYPE A) MONTH

The work under this Item shall conform to the relevant provisions of Subsection 740 of the Standard Specifications and the following:

Two computer systems and printer system meeting minimum requirements set forth below including installation, maintenance, power, paper, disks, and other supplies shall be provided at the Resident Engineer's Office:

All equipment shall be UL approved and Energy Star compliant.

The Computer System shall meet the following minimum criteria or better:

Processor:	Intel, 3.5 GHz
System Memory (RAM):	12 GB
Hard Drive:	500 GB
Optical Drive:	DVD-RW/DVD+RW/CD-RW/CD+RW
Graphics Card:	8 GB
Network Adapter:	10/100 Mbit/s
USB Ports:	6 USB 3.0 ports
Keyboard:	Generic
Mouse:	Optical mouse with scroll, MS-Mouse compliant
Video/Audio	the computer system shall be capable of allow video calling and recording:
Video camera	shall be High Definition 1080p widescreen capable video calling and recording with built in microphone. The microphone system shall capture natural audio while filtering out background noise.
Audio	shall be stereo multimedia speaker system delivering premium sound.
OS:	Latest Windows Professional with all security updates
Web Browser:	Latest Internet Explorer with all security updates
Applications:	Latest MS Office Professional with all security updates
	Latest Adobe Acrobat Professional with all security updates
	Latest Autodesk AutoCAD LT
	Latest Bluebeam Revu
	Antivirus software with all current security updates maintained through the life of the contract.
Monitors:	Two 27" LED with Full HD resolution. Max. resolution 1920 x 1080
Flash drives:	2 (two) - 128GB USB 3.0
Internet access:	High Speed (min. 24 mbps) internet access with wireless router.

ITEM 740. (Continued)

A Digital Camera shall meet the following minimum criteria or better:

Resolution:	12 Megapixel
Optical Zoom:	5x
Internal Memory Included:	Yes
Memory:	8 GB SD Card
Screen:	3 inch Clear Photo LCD
Min Operating Temperature:	14°F
Max Depth of Water Resistant:	30feet
Height of Shock Resistant:	5 feet
Battery Power:	2 rechargeable batteries and a battery charger
Carrying Case:	Rain-proof with shoulder strap

The Multifunction Printer System shall meet the following minimum criteria or better:

Color laser printer, fax, scanner, email and copier all in one with the following minimum capabilities:

- Estimated volume 8,000 pages per month
- LCD touch panel display
- 50 page reversing automatic document feeder
- Reduction/enlargement capability
- Ability to copy and print 11" x 17" paper size
- email and network pc connectivity
- Microsoft and Apple compatibility
- ability to overwrite latent images on hard drive
- 600 x 600 dpi capability
- 30 pages per minute print speed (color),
- 4 Paper Trays Standard (RADF) (not including the bypass tray)
- Automatic duplexing
- Finisher with staple functions
- Standard Ethernet. Print Controller
- Scan documents to PDF, PC and USB
- ability to print with authenticated access protection

The Contractor shall supply a maintenance contract for next day service, and all supplies (toner, staples, paper) necessary to meet estimated monthly usage.

The Engineer's Field Office and the equipment included herein including the computer system, and printer shall remain the property of the Contractor at the completion of the project. Disks, flash drives, and card readers with cards shall become the property of the Department.

Compensation for this work will be made at the contract unit price per month which price includes full compensation for all services and equipment, and incidentals necessary to provide equipment, maintenance, insurance as specified and as directed by the Engineer.

ITEM 748.11**MOBILIZATION FOR EMERGENCY REPAIRS****EACH**

The work under this Item consists of emergency mobilization for making immediate repairs to highway and bridge assets within the limits of construction outside of regular working hours, in accordance with Subsection 7.17 Traffic Accommodation.

Emergency Repair is defined as immediate work required for the safety and convenience of the traveling public. The contractor shall perform emergency repairs such as bridge joint and bridge deck repairs, guardrail and guardrail end repairs, and other repairs as specified by the Engineer.

The contractor shall commence this Emergency Work within twenty-four (24) hours after notification by the Department, unless otherwise directed. The nature of Emergency Work requires the Contractor to be available 24 hours per day. In addition to required construction Items, payment for any Emergency Repair work performed will include Item 748.11.

If the Contractor has not started physical work on an assigned Emergency Repair within twenty-four (24) hours from receipt of the notification, no payment under Item 748.11 shall be made subject to the discretion of the Engineer. Furthermore, the contractor will be assessed damages in the amount of \$1,000 per hour for each hour physical work is delayed.

The work includes movement of equipment, personnel, materials, traffic control devices, and incidentals to the location requiring emergency repair. When emergency work becomes necessary the Engineer will issue a work order describing the location and nature of the work to be completed.

METHOD OF MEASUREMENT AND BASIS OF PAYMENT

Mobilization for emergency repairs will be measured for payment by the unit Each, with each emergency mobilization work order issued by the Engineer measured as one unit. This item will be paid for at the Contract unit price per Each, emergency mobilization.

Measurement and payment will be made only once Each per work order regardless of the number of days required to complete the emergency repair.

This Item will only be measured and paid when work orders are issued for emergency repairs and will not be paid when repairs are necessary to the Contractors own work, or when repairs are made during regular work hours.

Payment for work other than the emergency mobilization will be made under the applicable contract items.

ITEM 767.121**SEDIMENT CONTROL BARRIER****FOOT**

The work under this item shall conform to the relevant provisions of Subsections 670, 751 and 767 of the Standard Specifications and shall include the furnishing and placement of a sediment control barrier. Sediment control barrier shall be installed prior to disturbing upslope soil.

The purpose of the sediment control barrier is to slow runoff velocity and filter suspended sediments from storm water flow. Sediment barrier may be used to contain stockpile sediments, to break slope length, and to slow or prevent upgradient water or water off road surfaces from flowing into a work zone. Contractor shall be responsible for ensuring that barriers fulfill the intent of adequately controlling siltation and runoff.

Twelve-inch diameter (after installation) compost filter tubes with biodegradable natural fabric (i.e., cotton, jute, burlap) are intended to be the primary sedimentation control barrier. Photo-biodegradable fabric shall not be used.

For small areas of disturbance with minimal slope and slope length, the Engineer may approve the following sediment control methods:

- 9-inch compost filter tubes
- Straw bales which shall be trenched

No straw wattles may be used. Additional compost filter tubes (adding depth or height) shall be used at specific locations of concentrated flow such as at gully points, steep slopes, or identified failure points in the sediment capture line.

When required by permits, additional sediment barrier shall be stored on-site for emergency use and replacement for the duration of the contract.

Where shown on the plans or when required by permits, sedimentation fence shall be used in addition to compost filter tubes and straw bales and shall be compensated under that item.

Sediment control barriers shall be installed in the approximate location as shown on the plans and as required so that no excavated or disturbed soil can enter mitigation areas or adjacent wetlands or waterways. If necessary to accommodate field conditions and to maximize effectiveness, barrier locations may be shifted with approval from the Engineer. Barriers shall be in place prior to excavation work. No work shall take place outside the barriers.

MATERIALS AND CONSTRUCTION

Prior to initial placement of barriers, the Contractor and the Engineer shall review locations specified on the plans and adjust placement to ensure that the placement will provide maximum effectiveness.

Barriers shall be staked, trenched, and/or wedged as specified herein and according to the Manufacturer's instructions. Barriers shall be securely in contact with existing soil such that there is no flow beneath the barrier.

ITEM 767.121 (Continued)**Compost Filter Tube**

Compost material inside the filter tube shall meet M1.06.0, except for the following: no peat, manure or bio-solids shall be used; no kiln-dried wood or construction debris shall be allowed; material shall pass through a 2-inch sieve; and the C:N ratio shall be disregarded.

Outer tube fabric shall be made of 100% biodegradable materials (i.e., cotton, hemp or jute) and shall have a knitted mesh with openings that allow for sufficient water flow and effective sediment capture.

Tubes shall be tamped, but not trenched, to ensure good contact with soil. When reinforcement is necessary, tubes shall be stacked as shown on the detail plans.

Straw Bales

Straw bales shall be used if shown on the plans or when specified by Orders of Condition or other permit requirements.

Bales should be placed in a single row, lengthwise on the contour, with ends of adjacent bales tightly abutting one another. All bales should be either wire-bound or string-tied. Straw bales should be installed so that bindings are oriented around the sides (rather than along the tops and bottoms) of the bales in order to prevent deterioration of the bindings.

The barrier should be entrenched and backfilled. A trench should be excavated the width of a bale and the length of the proposed barrier to a minimum depth of 4 inches. The trench must be deep enough to remove all grass and other material which might allow underflow. After the bales are staked and chinked (filled by wedging), the excavated soil should be backfilled against the barrier. Backfill soil should conform to the ground level on the downhill side and should be built up to 4 inches against the uphill side of the barrier.

Each bale should be securely anchored by at least 2 stakes or re-bars driven through the bale. The first stake in each bale should be driven toward the previously laid bale to force the bales together. Stakes or re-bars should be driven deep enough into the ground to securely anchor the bales. For safety reasons, stakes should not extend above the bales but should be driven in flush with the top of the bale.

The gaps between the bales should be chinked (filled by wedging) with straw to prevent water from escaping between the bales. Loose straw scattered over the area immediately uphill from a straw bale barrier tends to increase barrier efficiency. Wedging must be done carefully in order not to separate the bales.

When used in a swale, the barrier should be extended to such a length that the bottoms of the end bales are higher in elevation than the top of the lowest middle bale to assure that sediment-laden runoff will flow either through or over the barrier but not around it.

ITEM 767.121 (Continued)**Sedimentation Fence**

Materials and Installation shall be per Section 670.40 and 670.60 of the Standard Specifications and the following:

Sedimentation fence shall only be used if shown on the plans or when specified by Orders of Condition or other permit requirements.

When used with compost filter tubes, the tube shall be placed on a minimum of 8 inches of folded fabric on the upslope side of the fence. Fabric does not need to be trenched.

When used with straw bales, an 8-inch deep and 4-inch wide trench or V-trench shall be dug on the upslope side of the fence line. One foot of fabric shall be placed in the bottom of the trench followed by backfilling with compacted earth or gravel. Stakes shall be on the down slope side of the trench and shall be spaced such that the fence remains vertical and effective.

Width of fabric shall be sufficient to provide a 36-inch high barrier after fabric is folded or trenched. Sagging fabric will require additional staking or other anchoring.

MAINTENANCE

Maintenance of the sediment control barrier shall be per Section 670.60 of the Standard Specifications or per the Stormwater Pollution Prevention Plan (SWPPP), whichever is more restrictive.

The contractor shall inspect the sediment barrier in accordance with relevant permits. At a minimum, barriers shall be inspected at least once every 7 calendar days and after a rain event resulting in 0.25 inches or more of rainfall. Contractor shall be responsible for ensuring that an effective barrier is in place and working effectively for all phases of the Contract.

Barriers that decompose such that they no longer provide the function required shall be repaired or replaced as directed. If the resulting berm of compost within the fabric tube is sufficiently intact (despite fabric decay) and continues to provide effective water and sediment control, barrier does not necessarily require replacement.

DISMANTLING & REMOVING

Barriers shall be dismantled and/or removed, as required, when construction work is complete and upslope areas have been permanently stabilized and after receiving permission to do so from the Engineer.

Regardless of site context, nonbiodegradable material and components of the sediment barriers, including photo-biodegradable fabric, plastic netting, nylon twine, and sedimentation fence, shall be removed and disposed off-site by the Contractor.

ITEM 767.121 (Continued)

For naturalized areas, biodegradable, natural fabric and material may be left in place to decompose on-site. In urban, residential, or other locations where aesthetics is a concern, the following shall apply:

- Compost filter tube fabric shall be cut and removed, and compost shall be raked to blend evenly (as would be done with a soil amendment or mulch). No more than a 2-inch depth shall be left on soil substrate.
- Straw bales shall be removed and disposed off-site by the Contractor. Areas of trenching shall be raked smooth and disturbed soils stabilized with a seed mix matching adjacent seeding or existing grasses (i.e., lawn or native grass mix).
- Sedimentation fence, stakes, and other debris shall be removed and disposed off-site. Site shall be restored to a neat and clean condition.

METHOD OF MEASUREMENT AND BASIS OF PAYMENT

Item 767.121 will be measured and paid for at the contract unit price per foot of sediment control barrier which price shall include all labor, equipment, materials, maintenance, dismantling, removal, restoration of soil, and all incidental costs required to complete the work.

Silt fence, when used in conjunction with compost filter tubes or straw bales, will be incidental to this item.

Additional barrier, such as double or triple stacking of compost filter tubes, will be paid for per foot of tube installed.

Barriers that have been driven over or otherwise damaged by construction activities shall be repaired or replaced as directed by the Engineer at the Contractor's expense.

ITEM 819.907**INSTALL 3 LANE CLASSIFICATION
TRAFFIC DATA STATION****EACH**

Work consists of furnishing and installing **two (2)** new cabinets with **two (2)** new post mounted **60- Watt** solar panels on a foundation at the specified locations. The existing foundation and pull box may be used in the new installations if deemed to be in acceptable condition by the MassDOT Resident Engineer. For any existing Traffic Data Collection Cabinets and associated equipment being removed shall be delivered to the Traffic Counting section of the Massachusetts Department of Transportation. A dated receipt indicating the MassDOT contract number, the number of cabinets, and the count station numbers shall be supplied at delivery. The contractor and MassDOT Engineer shall ensure Misrak Sultan is contacted at the email address Misrak.Sultan@dot two weeks prior to start of any work in the vicinity of the traffic count station, including but not limited to roadway resurfacing or cabinet removal so that the existing cabinet internal data collection equipment can be safely removed and for cabinet delivery arrangements. TDC shall be notified of the work schedule of all work associated with the traffic count station so that the MassDOT Traffic Data Collection section has the opportunity to witness any work as deemed necessary including the road sensor installation. Work at each location includes installing six (6) 6' x 6' loop detectors, six (6) 11-foot class II piezo sensors, lead-in cables, pull box, conduit, and electrical connections as shown on enclosed drawings "Traffic Data Collection Stations", "Typical Loop Wire Installation", and "Loop Detector Construction Details". **Piezo installation procedures established by the manufacturer shall be adhered to ensure proper operation. A manufacturer factory representative shall be present to monitor and assist with the piezo installation process.** The contractor has full installation responsibility and may install without the manufacturer present if they were previously trained during the current construction season by a manufacturer representative. The loop and piezo leads shall go from the pavement edge underground in conduit through the pullbox and end on the terminal strip in the cabinet. **No splices are allowed in the piezo sensor leads and it is preferred that there are no splices in the loop sensor leads.** Each sensor shall have a separate flex conduit from the roadway to the pullbox. **The flex conduit shall be a minimum of six (6) inches below ground level including at the road edge. The roadway sensor lead-in wires shall enter the flex conduit via a drilled hole in the pavement. Roadway loop wires and piezos shall be installed in the final finished surface of the pavement as per manufacturer specification. The piezo sensor shall be installed no more than 3/4" deep from the final finished surface of the pavement. If the contract includes milling, the roadway loop wires, and piezo sensors shall be installed after the surface course has been installed over the milled surface. All road sensors shall not be exposed and shall be covered by epoxy resin as per manufacturer specifications. Any epoxy applied over the piezo installations shall be ground flush with the pavement surface so as not to be impacted by snowplows during the winter months.** The road sensors are to be installed in a relatively straight and flat roadway section away from any lane changing ramp traffic. The contractor shall verify the top surface lane marking locations with the MassDOT Resident Engineer to ensure that the loop and piezo subsurface roadway sensors will be centered in each lane. The contractor shall carefully measure and record the actual distances between all installed sensors in each lane on the cabinet layout drawing. Each loop and piezo shall be given the number shown on the "Traffic Data Collection Stations" drawing and that number shall be clearly designated on both the terminal board and the cabinet drawing. All loop and piezo testing shall be done both before and after the sensors saw-cuts are covered by epoxy.

ITEM 819.907 (Continued)

Work shall also include all other items (whether or not specified) necessary to make the installations operate as a classification, volume, and speed data collection station. One (1) Backup battery is required for each cabinet per specifications. This work applies to the following two (2) count stations.

EXISTING CABINET LOCATION: Route I-91 West Springfield (TDC Station # **2797-NB**). The existing cabinet is located approximately 5' behind the guardrail, 332' south of MM 10.2. GPS coordinates of this location: Latitude N42.143966, Longitude – W72.639798

PROPOSED CABINET LOCATION: Route I-91 West Springfield (TDC Station # **2797-NB**) The existing cabinet is located approximately 5' behind the guardrail, 946' of MM 10.2. GPS coordinates of this location: Latitude N42.142604, Longitude – W72.638492

EXISTING CABINET LOCATION: Route I-91 West Springfield (TDC Station # **2797- SB**). The existing cabinet is located approximately 5' behind the guardrail, and 266' South of MM 10.0. GPS coordinates of this location: Latitude N42.141499, Longitude – W72.638179

MATERIALS

The MassDOT Resident Engineer shall consult with the Traffic Data Collection section regarding all count station material (catalog cut) submittal approvals. Disposal of existing equipment, if necessary, shall be in accordance with the 2023 Massachusetts Department of Transportation (MassDOT) Standard Specifications for Highways and Bridges section 815.65.

The following sole source manufacturer equipment shall be installed under this item:

- IRD TRS WIM traffic recorder.
- TE Connectivity Roadtrax BL piezo sensor.
- PAT/IRD TRS solar harness.
- Morningstar Sunsaver SS-MPPT-15L regulator.
- Morningstar Ethernet MeterBus Converter EMC-1 ethernet connectivity.
- Sierra Wireless AirLink RV50X modem.

PIEZO SENSORS

The twelve (12) total piezo for item **819.907** (6 per location) shall be **11-foot length Class II** polymer piezo sensors designed for permanent roadway installation (2 per lane)) with the system capable of gathering classification, speed, and volume traffic data. The sensor shall be installed directly into the road at a depth of no more than ¾" without an aluminum channel or epoxy encapsulation on the sensor. The Piezo sensor shall be TE Connectivity (formally Measurement Specialties Incorporated - MSI) Roadtrax BL or approved equal. The piezo shall be supplied with 100 feet of transmission cable unless otherwise specified and shall have lightning surge protection. The epoxy grout used to seal the piezo in the road surface slot shall be per piezo manufacturer requirements for the installed roadway surface and for the area climate conditions. The piezo epoxy has a limited shelf life and storage temperature requirements. Expired or improperly stored epoxy does not set properly and will not be allowed on any piezo installations. The sawcut must be clean and dry prior to the piezo and epoxy installation.

ITEM 819.907 (Continued)

No splices shall be allowed in the piezo cable. The contractor shall adhere to the Piezo installation procedures established by the manufacturer to ensure proper operation. A manufacturer factory representative shall be present to monitor and assist with the piezo installation process. The contractor has full installation responsibility and may install without the manufacturer present if they were previously trained during the current construction season by a manufacturer representative. MassDOT Traffic Data Collection section, Misrak.Sultan@dot.state.ma.us shall be notified a minimum of two weeks prior to the proposed piezo installation date.

TE Connectivity (formally MSI) and two additional piezo vendors can be contacted at the following addresses:

TE Connectivity (MSI) Sensor Solutions 1050 Westlakes Drive Berwyn, Pa 19312 Phone: (610) 893-9800	Diamond Traffic Products 76433 Alder Street P.O. Box 1455 Oakridge, OR 97463 Phone: (541) 782-3903 Fax: (541) 782-2053	International Road Dynamics Inc. 2402 Spring Ridge Drive Suite E Spring Grove, IL 60081 Phone: (815) 675-1430 Fax (815) 675-1530
--	---	---

TYPE CB CABINET

The **two (2)** total furnished new and installed cabinets for Item **819.907** (1 per location) shall be a weatherproof aluminum cabinet identified as type "CB". The cabinet shall be base mounted and bolted to a standard (not core type) cement concrete foundation equipped with a ground rod, all in accordance with the applicable requirements of Section 800 of the Standard Specifications. Existing foundations that are utilized in a new installation (deemed as acceptable by the MassDOT Resident Engineer) are to be repaired or replaced as necessary to ensure that the installed cabinet is level. The new cabinet installations shall be secured to the foundation with 4 anchor bolts (3/4" x 15 3/4") instead of the standard 2 bolts to minimize potential damage due to snow being pushed into the cabinet by snowplows. The contractor shall ensure that the foundation anchor bolts, washers, and nuts are completely installed within the cabinet base slot/hole, fully engaged with the cabinet base, and securely tightened. The foundation where the cabinet rests shall be level. The cabinet bases and entry conduit shall be sealed against dust and moisture penetration and shall have a weather-stripped door. A clear silicone sealer shall be used at the base of the cabinet to form a water-tight seal with the foundation. The cabinet shall not have a door switch compartment (police door).

Guardrail shall be installed for cabinet protection if required. Any required guardrail work in the vicinity of the count station shall be scheduled prior to the road sensor installation to avoid potential damage to the road edge leads/conduit. If this is not possible, the road edge leads/conduit shall be unearthed and clearly identified, the guardrail works closely monitored, and the road sensor leads tested before and after the guardrail works in the presence of the MassDOT Resident Engineer. The Type CB Cabinet and foundation shall be set back a minimum of 5 feet from the back of the Guard Rail, unless otherwise directed by the Mass DOT Engineer. Cabinets shall not be installed close to the guardrail due to the potential damage of snow being pushed into the cabinet by snowplows.

ITEM 819.907 (Continued)

The cabinet shall be installed with the door opening positioned in order to allow observation of the flow of traffic and the inside of the cabinet at the same time. (You should be facing the roadway traffic when looking into the opened cabinet). This will also keep the door away from the plowed snow. Grading in the foundation area shall be in accordance with Subsection 170 of the Standard Specifications. Grading in the area of the pullbox and cabinet foundation shall include a minimum of 3 foot wide (in all directions) and a 1-inch-thick top layer of material (i.e. stone, pavement millings, etc.) to deter soil erosion and vegetation growth. A 3 feet x 3 feet x 4 inches concrete pad over an 8-inch gravel base shall be provided in front of the cabinet door. When the station is located in a low point or flat area, a 5-ft berm is required in front of the pullbox in each direction, (10-ft in total) to protect the structure from water percolation and roadway debris.

Each cabinet furnished shall be equipped with the following:

1. Two (2) height adjustable shelves. The lower shelf shall be used for the backup battery and shall have insulated material under the battery to inhibit power drainage. The other shelf shall be spaced to allow wiring access to the terminal boards, regulator, and convertor.
2. Vents with installed washable **metal** replaceable air filters.
3. A thirty- (30) position double row barrier strip for the spade tongue type lugs shall be installed above each of the shelves. A gas-tube surge arrester (Type TII-317-A) shall be installed on the barrier strip for each terminated loop.
4. A standard traffic lock with 2 keys.
5. The exterior finish of all housing shall have two (2) coats of green enamel paint over a corrosive resistant primer coat. All paint shall conform to Standard Specification Subsection 815.61.
6. The concrete foundation (4000 psi $\frac{3}{4}$ " Class D) shall conform to the MassDOT latest editions of "Standard Drawings for Traffic Signals and Highway Lighting" and "Standard Specifications for Highways and Bridges", or as directed by the Engineer. Foundations shall have a total of three 3" diameter conduit sweeps installed. Sweeps not used shall be capped and sealed.

The Type CB cabinet will require the installation of a post mounted solar panel to power the Traffic Data Collection instruments. The standard hook up to the traffic data collector is shown in the attached typical drawing "Standard Solar Panel Connection to Traffic Data Collectors".

ITEM 819.907 (Continued)**SOLAR PANELS AND SUPPORT POSTS**

The **two (2)** total furnished new and installed post mounted **60-Watt** solar panels for Item 819.907 (1 per cabinet) shall include all necessary mounting hardware, sealer, voltage regulator, terminal boards, and recorder battery connections including the solar charging harness cable. The solar harness shall be a PAT/IRD TRS harness for classification and volume stations. The solar charging harness shall connect to the regulator/terminal board voltage source with 2 spade lug connectors and shall connect on the other end to the recorder with an AMP connector. The solar harness must fit the PAT/IRD recorder version 4.07 or newer. The solar charging harness can be purchased or manufactured by the Contractor. Information on the PAT/IRD dual communication TRS recorder connection and solar charging harness can be obtained by calling PAT/IRD at (815) 675-1430. The solar panel with tilting capabilities shall be **post mounted** per the attached "Solar Panel Mounting Detail" drawings. The Photovoltaic panels shall be 60-Watt crystalline silicon photovoltaic arrays modules with anodized aluminum frame and adjustable mounting brackets with nominal dimensions of approximately 21" x 33" or a surface area of no more than 963 Square Foot. A 65-Watt solar panel with approximate dimensions 20" x 40" (maximum) can be substituted if installed per the May 2021 version of the Solar Panel Mounting Detail drawing. The solar panel shall be mounted to maximize the solar capabilities of the site (orientated toward the south and tilted at an angle of approximately 30-40 degrees) as well as minimize vandalism. All holes made in the cabinet during installation shall be sealed.

Photovoltaic panel support posts shall be fabricated from galvanized 2 ¼"x 2 ¼" square steel tube meeting the requirements of ASTM A1011, Grade 50 from an approved manufacturer and conforming to the requirements of Subsection M8.18.3, Sign Supports, for Type P5 Signpost of the Standard Specification. Posts shall be galvanized in accordance with ASTM A653, Coating Designation G140 with a minimum coating of 1.4 ounces per square foot total of zinc on all sides under triple spot tests; or a minimum coating of 1.15 ounces per square foot total on all sides under triple spot tests. All bolts, nuts washers and miscellaneous hardware shall conform to the requirements of ASTM A307 and shall be galvanized unless otherwise specified. Galvanizing shall conform to AASHTO M232, Zinc Coating (Hot Dip) on Iron and Steel Hardware, and as further specified in Subsection M7.10.0 Galvanized Coatings of the Standard Specifications. Work shall conform to the relevant provisions of Subsection 828, Traffic Signs, and Subsection 840, Sign Supports of the Standard Specifications, and these Provisions.

The contractor shall verify existing or proposed cabinets are installed on concrete foundations and anchorage is as specified in Subsection 815 of the Standard Specifications, consisting of ¾" x 16" anchor bolts. Post shall be mounted on the equipment or signal cabinets as shown in the Typical Installation Details. Fasteners spacing may be adjusted within the parameters defined on the Typical Installation Detail Drawings. Fastener location and spacing shall be such as to avoid interference with existing or future control or switching devices located within the cabinet and shall not exceed the allowable parameters shown on the Typical Installation Detail Drawing. Galvanized washers shall be used beneath the nut at the interior side of the traffic cabinet for all bolted connections. For installations where access constraints require the head of the bolt be located at the interior side of the cabinet, a galvanized washer shall be used under the head of the bolt at the interior of the cabinet and a galvanized washer shall still be used beneath the nut at the exterior side of the connection. Solar panels shall be mounted to the support post using a minimum of 2 bolts per connection. Mounting bolts shall be of the size shown in the drawings and shall be galvanized.

ITEM 819.907 (Continued)**CHARGE CONTROLLER WITH ETHERNET CONNECTIVITY**

The **two (2)** total furnished new and installed regulators for Item 819.907 (1 per cabinet) shall be capable of supplying charges to a 12-volt deep cell, marine backup type battery application. The regulator shall be Morningstar Sun saver SS-MPPT-15L or approved equal equipped with battery status indicator lights, a low voltage disconnects (LVD), a low voltage reconnect (LVR), and the latest available firmware. A 6AMP 12V DC circuit breaker is required for the solar input and for each of the load and battery circuits. The charge controller and all necessary circuit-breakers shall be mounted on a pre-wired backplate. Each of the solar input, battery input and load output shall be wired through power terminal blocks that are din-rail mounted on the pre-wired backplate. **A spare circuit breaker** shall be supplied and left in a clear plastic bag in the cabinet. IP-based Ethernet connectivity to the charge controller shall be included and installed (one per cabinet) to allow remote interfacing and status tracking of the charge controller. The Ethernet connectivity shall be Morningstar Ethernet MeterBus Converter EMC-1 or approved equal with status indicator lights, a standard RJ-45 port for Ethernet connection to a cellular modem, and a MeterBus port (RJ-11) to allow connection to the charge controller. Switch 1 shall be set to "ON" and battery input metal jumpers on the charge controller should be removed as per manufacturer specifications for use with AGM type batteries specified below. In addition, Switch 4 shall be set to "ON" on the charge controller shall be set to allow remote communication using MODBUS® protocol or vendor-provided software.

Morningstar and two additional vendors can be contacted at the following addresses for the charge controller with Ethernet connectivity:

Morningstar Corporation 8 Pheasant Run Newtown PA, 18940 Phone: (215) 321-4457 Fax: (215) 321-4458 info@morningstarcorp.com	Go Green Solar 330 E. Orangethorpe Ave Placentia CA Phone: (866) 798-4435 Fax: - info@gogreensolar.com	Northern Arizona Wind and Sun 4091 E. Huntington Drive Flagstaff AZ 86004 Phone: (800) 383-0195 Fax: (928) 527-0729 windsun@wind-sun.com
--	--	---

BACKUP BATTERIES

The **two (2)** total new rechargeable **12 Volt 110 AMP HR minimum AGM** backup batteries for Item 819.907 (1 per cabinet) shall be furnished new and installed in the cabinet to sufficiently power the traffic recorder and telecommunication equipment. These batteries shall be equipped with any necessary adapters, connectors, and wired through a 12V DC 6 AMP circuit- breaker to the specified solar panel regulator. All wires shall be color coded as red for positive and black for negative. Back-up batteries should be installed in the cabinet in order to avoid blocking access to ALL terminal boards in the cabinet (loops, piezos, solar, regulator, etc.). The backup batteries shall be placed on insulated material to inhibit power drainage. *The Contractor shall submit cut-sheets for the batteries as part of the shop drawing submittal for approval. The cut-sheets shall provide sufficient information for MassDOT to determine the reserve capacity of the battery.*

ITEM 819.907 (Continued)**WIRELESS MODEM & ANTENNA**

The **two (2)** total furnished new and installed wireless modems for Item 819.907 (1 per cabinet) shall be industrial grade, LTE advanced performance, low power consumption with simplified deployment and remote management capabilities. The wireless modem shall be provided with an approved antenna (1 per cabinet) with a standard SMA connector. The modem (Sierra Wireless AirLink RV50X or approved equal) shall meet the following requirements.

Cellular Wide Area Network (WAN): The modem shall be approved to operate on the Verizon Wireless network and shall support frequency bands associated with 4G/LTE, and 3G/EV-DO/CDMA. The modem shall have all necessary industry and FCC approvals. The modem shall incorporate a software-defined radio with automatic network operator switching and dual SIM interfaces.

Cellular Antenna: The antenna shall operate on the Verizon Wireless 4G/LTE and 3G/EV-DO/CMDA frequencies. The Contractor shall provide and install an external omnidirectional antenna. The antenna shall have a gain of at least 0 dB, and not more than 4 dB. The antenna shall have a minimum of two (2) cables with appropriate connectors that mate with the modem antenna interfaces as specified above, with one cable and connector dedicated to the primary 4G LTE cellular services and the other cable and connector dedicated to the diversity 4G LTE cellular service. The antenna shall also have a separate cable and connector dedicated to GPS. The external antenna shall be on a protected mount, weatherproof and of the type that is specifically designed for outdoor applications. It shall include a weatherproof covering that protects the antenna elements from snow and ice buildup. The antenna shall be mounted on the cabinet. The lead-in cables between the external antenna and the cabinet shall be an ultra-low-loss coaxial cable as specified by the antenna manufacturer. The cable loss shall not exceed 4 dB per one hundred (100) feet of length at a frequency of 700 MHz. The Contractor shall install the antenna cabling using a bulkhead fitting or a sealing material, grommet, or other sealing system to protect the antenna cable from damage and to maintain the environmental rating of the cabinet.

Signal Strength: The cellular signal strength as measured by the Received Signal Strength Indicator (RSSI), shall be -78 dBm or greater, and the Contractor shall take all means necessary to ensure that this signal level, or greater, is available to each project modem. Any deviations from the means described herein shall be approved by the Engineer prior to installation. While high gain unidirectional antennas would be considered, note that it is MassDOT's current policy to not allow the use of signal booster amplifiers. In the event that a high gain unidirectional antenna is proposed by the Contractor and accepted by MassDOT, the Contractor shall aim the antenna as follows: The Contractor shall aim the antennas in a manner that yields the maximum achievable signal strength at each location. The Contractor shall rotate the antenna through a full 360 degrees of rotation while monitoring the received signal strength. The antenna shall be permanently secured at the rotational position that yields the maximum signal strength. With the antenna at this optimal position, the received signal strength, as seen by the cellular modem, and in units of decibels relative to one milliwatt (dBm), shall be recorded by the Contractor, and shall meet the requirements stated herein. The costs for the additional material, labor, cabling, mounts, antenna, and hardware shall be included in this item.

ITEM 819.907 (Continued)

The Contractor is responsible for conducting his own signal strength site survey and ascertaining signal levels at each of the project sites. The Contractor shall supply all required accessories to obtain acceptable signal strength at the cellular modem inside the cabinet.

Interfaces: The modem shall provide the following interfaces: 10/100/1000 Ethernet through a standard RJ-45 port, RS-232 serial through a standard 9-pin (DB-9) port, USB 2.0 through a Micro-B connector. The modem shall have SMA interfaces for an approved cellular antenna with support for both primary and diversity connections, and an approved GPS antenna.

Input/Output: The modem shall provide a digital input/output (I/O) pin that can be configured as well as an analog input that is capable of accepting 0.5-36 VDC.

Network Interfaces: The modem shall provide the following IP features including but not limited to Network Address Translation (NAT), port forwarding, host port reporting, and dynamic DNS. The modem shall support secure Virtual Private Network (VPN) through IPsec, GRE, and Open VPN client. Up to 5 concurrent VPN tunnels shall be supported. The modem shall have Dead Peer Detection (DPD) and support multiple subnets. The modem shall support inbound and outbound port filtering, inbound and outbound trusted IP, MAC address filtering, DMZ and support remote authentication using LDAP, RADIUS, TACACS+.

Event Reporting: The modem shall have the capability to trigger event reports based on digital input, network parameters, data usage, timer, power, device temperature and voltage.

User Software: The modem shall be provided with an application framework to allow development, testing and execution of user-written software written in a web scripting language.

Power: The model shall accept 7 to 36 VDC input voltage. When idle, the modem power consumption shall be no more than 900 mW (75 mA @ 12 VDC). In addition, the modem shall have the capability to be placed in standby power mode with a power consumption of no more than 53 mW (4.4 mA @ 12 VDC) triggered by a periodic timer or the I/O pin.

Environmental: The modem shall have an operating temperature range of -30 deg C to +70 deg C; 90% relative humidity; IP64 rated ingress protection; and conform to military specifications for shock, vibration, thermal shock, and humidity.

Warranty: The modem shall have no less than a three (3) year standard warranty.

Contact information for Sierra Wireless and two additional vendors are listed below:

Sierra Wireless, Inc. 400 Interstate N Pkwy #900 Atlanta GA 30339 Phone: (604) 231-1100	Digi International 11001 Bren Road East Minnetonka, MN 55343 Phone: (877) 912-3444	Red Lion Controls, Inc. 20 Willow Springs Circle York PA 17406 USA Phone: (717) 767-6511
--	---	---

ITEM 819.907 (Continued)**ROADWAY LOOP DETECTORS**

The twelve (12) total wire loop detectors (2 per lane) for item **819.907** (6 per location) will conform to the following:

1. LOOP WIRE

Shall be single conductor, No. **12 AWG**, stranded copper wire, cross-linked polyethylene insulated, rated 600 volts, type XLP-USE. The loop wire shall be encased in a 1/4" OD flexible plastic tubing formed by continually extruding the tube over the wire assembly, allowing the wire to slip freely within the tubing. Loop wire shall conform to IMSA specification 51-5.

2. CONNECTIONS

Shall be made with approved terminals or connectors applied with a crimping tool (Per Standard Specifications Subsections 813.60, 815.64).

3. SAWCUT SEALANT

The saw-cuts shall be filled with an approved roadway loop embedding sealer to protect the wire. (Standard Specification Subsection 815.64)

4. FLEXIBLE METALLIC CONDUIT LIQUID TIGHT

Shall be in accordance with Material Subsection M5.07.2B or an approved equal.

5. PULL BOXES

Pre-cast or cast-in-place boxes shall conform to typical details. The pull boxes specified will be 12"x 12" or 12"x 24" as shown in the Standard Drawings for Traffic Signals and Highway Lighting, latest edition. The size specified for each application is shown on the provided construction sketches.

Before the contractor can occupy the public way, the following materials and equipment must be **on site**.

a. Power Saw:

Self-propelled of at least 35 HP equipped with a diamond blade capable of cutting a 5/16" slot, water valve, depth gauge and horizontal guide.

b. Water Supply:

Adequate to cool diamond saw blade and clean saw slots.

c. Air Compressor:

To clean and dry saw cuts.

d. Drill:

Capable of drilling a 1 1/4" diameter hole at the corners of the loop prior to sawing. The drill shall also be equipped with a paddle mixer attachment for mixing epoxy.

ITEM 819.907 (Continued)

e. Blunt Tool:

Such as a wooden paint stirring stick for seating the wire in the slot; no screwdrivers or any other pointed tools shall be allowed.

f. Twister:

To provide symmetrical twists of the lead-in wire.

g. Template/Straight Edge:

For marking the outlines of the loops on the pavement.

h. Trenching Machine:

For burying cable in soil.

i. Meter:

To test continuity, capacitance, resistance and inductance of the loops as specified.

j. Electric Soldering Iron:

An electrical pencil soldering iron not exceeding 35 watts for soldering connections.

k. Measuring Tape:

Minimum 100' tape for exact measurements for placement of loops.

l. Traffic Control Devices:

All traffic control devices required by the traffic control plan must be available and in place on the roadway prior to occupation of the roadway for purposes of work.

m. Traffic Police:

If a police detail is authorized, for the site, the officer must be present prior to entering the highway. Under no circumstances shall a limited access highway be occupied without a traffic officer present.

ROAD SENSOR INSTALLATION

The location of each loop/piezo sensor and loop/piezo leads shall be marked on the pavement, using the typical layout shown on the plans, and approved by the Engineer before cutting the slots. **The sensors shall be located in the final finished surface of the pavement.** Piezo installation is preferred in a straight, level section of the roadway. Sensors shall not be installed near expansion joints in a concrete roadway installation. A power saw of at least 35 HP equipped with a diamond blade shall be used to cut a slot in the pavement. The saw can be wet or dry at the discretion of the contractor and MassDOT Resident Engineer. The saw must be equipped with a depth gauge and horizontal guide to assure proper depth and alignment of the slot. The diamond blades to be utilized for the saw cut shall provide a clean, well-defined saw cut without damage to adjacent areas.

ITEM 819.907 (Continued)

The saw cut for loops shall be 5/16" wide and 2" deep, or as directed by the engineer. The saw cut for **piezos shall be 3/4" wide and no more than 3/4" deep**, or as directed by the engineer. A 1 1/4" diameter hole shall be drilled at each intersecting sawcut or lead in angle point to prevent sharp bends in the loop/piezo cable. All loop cuts and drilled holes shall be to the full 2" depth. It is critical that the saw cuts be as straight as possible; parallel each other, and perpendicular to the axis of the lane. All saw cuts connecting the loops/piezos with the edge of pavement must be separated by at least 1 foot. This separation is necessary to preclude the premature breaking up of pavement.

It is strongly recommended that a single 3/4" wide saw cut be used for the piezo slots. The loop/piezo slots and pavement shall be flushed with clean water to remove the saw slurry. Filtered compressed air shall be used to remove all dust and moisture from the sawcut slots. Sand or other moisture absorbing materials shall not be used in the slot. The piezo slot shall be additionally cleaned using appropriate solvents to remove any oil as instructed by the manufacturer's specifications. The installation of the loop/piezo in the slots will not take place until the slot is clean and completely dry. The piezo manufacturer's installation instructions shall be adhered to as closely as possible to ensure correct operation.

A flexible metallic PVC jacketed conduit shall be installed between the pavement and pull box in accordance with the attached "Loop Detector Construction Details". The flex conduit shall be a minimum of six (6) inches below ground level including at the road edge. The roadway sensor lead-in wires shall enter the flex conduit via a drilled hole in the pavement.

The loop wire shall be installed without damage to the wire or its insulation, starting at the pull box and around the loop for the specified four (4) turns and then back to the pull box as shown on attached "Typical Loop Wire Installation". The sensor wire shall be laid in the slot so there are no kinks or curls and no stretching of the insulation and shall be installed as far down in the slot as possible. A blunt object, similar to a wooden paint stirrer should be used to seat the loop sensor wire. In no case shall a screwdriver or other sharp tool be used for this purpose.

The loop wires between the edge of loop and the splice to the shielded lead-in cable in the pull box shall be twisted together to provide three (3) turns per foot.

CONNECTIONS

Each sensor loop and piezo lead shall run from the roadway edge in flex conduit through the pullbox and into the cabinet without any splices. Each sensor lead shall have a separate flex conduit. Multiple loops and piezo sensors shall be identified (colored tape or fiber tags) at each location. The lead-in conductors shall be connected to appropriate terminals in the Type CB cabinet using crimped and soldered terminal ends (**Type A only**).

Do not leave excess sensor wire slack or wiring for old, milled sensors in the cabinet or the pullbox. Excess wire or coiled wire may create another loop or create crosstalk between the loops thus reducing roadway sensitivity.

ITEM 819.907 (Continued)

Each loop and piezo shall be given a number and that number shall be clearly designated at the terminal board. The enclosed drawings “Traffic Data Collection Stations” for each site shall be used for the loop and piezo numbering system. The drawings shall be full sized (8 ½ inches x 11 inches), protected by a clear plastic cover, and attached to the inside of the cabinet door.

TESTING OF LOOPS AND PIEZOS

The following test procedure shall be performed in the presence of the Engineer before and after the loop sensor is sealed in the pavement as detailed below. The enclosed “Loop Detector Test Data Sheet” and “Piezo Detector Test Data Sheet” shall be used to record the test results and the Contractor shall obtain signature of the Engineer present during testing and submit the test results to MassDOT. The cost of equipment, labor, and materials to perform such testing and similar re-testing following repairs, replacement, or adjustment of any detector within the project area shall be included in the price bid for the Traffic Data Collection Station for that location.

After installation of loop wire in the roadway and installation of shielded lead-in connecting the loops to the cabinet or pull box, each loop sensor and/or lead-in combination shall be tested for proper installation. The resistance (R) from lead to lead of the same loop shall not exceed three (3) ohms per one thousand (1,000) feet as measured by a high-quality meter suitable for measurements of low resistance. The quality of each loop tested (Q value) shall be no less than 5. The measured inductance of each loop (L) shall conform to calculated inductance values after accounting for the size of the loop, the number of turns, and the inductance of the loop lead-in length.

A megohm meter test at 500 volts D.C. shall be made between the two leads of a loop/lead-in combination temporarily spliced together, but otherwise disconnected from all terminals, and the shielded drain wire and then the earth ground connection. The resistance for both tests shall be at least one hundred (100) megohms.

A megohm meter test at 500 volts D.C. shall be made between lead-in shield and the earth ground rod. This resistance shall be at least one hundred (100) megohms.

The piezo sensor shall be tested in accordance with the manufacturer specifications before and after the piezo sensor is sealed in the pavement. **The Contractor shall submit waveforms of the voltage changes from each piezo sensor captured using a suitable field oscilloscope to record the waveform of the voltage changes for each piezo sensor installed. The waveforms shall be captured for a minimum of ten (10) vehicles.** A copy of the manufacturer factory test data and the contractor completed piezo test results (capacitance, dissipation, resistance, etc.) shall be forwarded to the MassDOT Traffic Data Collection section.

If any loop sensor/piezo and lead-in combination fails to pass any of the above tests, it shall be repaired and then re-tested on two occasions at least two (2) weeks apart, and then shall pass on each re-test occasion. If the loop sensor/piezo lead-in combination does not pass all these re-tests, a new loop sensor and/or lead-in shall be installed, and shall pass these tests, at no additional cost. This shall be repeated until the required tests are all satisfactory.

ITEM 819.907 (Continued)

After the above tests have been satisfactorily completed, all loop wire and shielded lead-in inductances shall be measured and a written report of the results shall be filed with the MassDOT Resident Engineer along with a copy of the ground electrode, resistance tests required by Standard Specification Subsection 813.62B. An original signed copy of the completed “Loop Detector Test Data Sheet” and “Piezo Detector Test Data Sheet” and piezo sensor waveforms shall be forwarded to the MassDOT Traffic Data Collection section. Attention is directed to Subsection 815.66 of the 2023 MassDOT Standard Specifications, portions of which apply to these Special Provisions.

GROUND RESISTANCE TESTING

The contractor shall conduct a ground electrode resistance test as required by the Standard Specifications Subsection 813.62B. The resistance test shall be done in the presence of the Engineer using a ground resistance tester that is capable of 3-point ground resistance measurement with a resolution of 0.01 Ohms and an accuracy of +/- 1%. As per the MassDOT Standard Specifications, the ground electrode resistance shall be less than 25 Ohms. The Contractor shall install additional ground electrodes as needed to ensure the resistance meets the MassDOT requirement.

GUARANTEE

For a period of one (1) year after date of acceptance, the awarded Contractor shall replace or repair at no charge, any part or component that fails or does not function properly and if necessary, will provide technical assistance on site to aid in repair or replacement of faulty components.

TESTING OF FIELD STATIONS

The field stations shall be thoroughly tested by the Contractor in the presence of the MassDOT Resident Engineer in all functions required by these specifications or included in the normal design or function of the equipment as normally provided.

ACCEPTANCE

The system will be tested and evaluated for acceptance upon completion of installation of the field station. *Contact MassDOT Traffic Data collection (TDC) at the email address Mirak.Sultan@dot upon completion of the field station installation.* Acceptance will be given after a 30-day period of trouble-free operation and after MassDOT reviews the collected data to ensure that the station is functioning properly. The 30-day period will begin after all testing has been completed and approved by MassDOT and after the installed recorders start collecting valid traffic data. In addition, the 30-day period shall begin no earlier than May 1st and end no later than October 30th. **It is important for the Contractor to note that the 30-day acceptance testing shall only be done between May 1st and October 30th of each calendar year.**

ITEM 819.907 (Continued)

METHOD OF MEASUREMENT

Item 819.907 will be measured per each 3 Lane Classification Traffic Data Station installed complete in place.

BASIS OF PAYMENT

Item 819.907 will be paid for at the contract **each bid price** complete in place. Such payment shall be full compensation for all labor, materials, and equipment, and includes foundation, cabinet, solar panel, mounting bracket, mounting post, regulator, modem, antenna, solar charging harness, backup batteries, roadway loop detectors, roadway class II piezo sensors, lead-in cables, pull boxes, conduit, fasteners, and electrical connections including testing and all incidental costs required to complete the work.

ITEM 819.907 (Continued)



936 Elm Street
Concord, MA 01742
TEL: 978-287-6117
FAX: 978-287-6118

LOOP DETECTOR TEST DATA SHEET

Project: 612097 Count Station: _____
 Location: _____ Date: _____
 Data Taker: _____ Organization: _____

Loop Length	Loop #	Approach Direction, Lane #, Leading or Trailing Loop	meg-Ohms to Ground			meg-Ohms Loop to Shield	Comments
			L	Q	R		

Witness: _____ Date: _____ Organization: _____
 Witness: _____ Date: _____ Organization: _____

Notes: Typical Loop: size 6'x6', wire gauge # 12 AWG (IMSA 51-5), 4 turns. Note any unusual sizes in the "Comments" column.
 Loop Length: Total distance from the cabinet termination thru pullbox, conduit, the loop lead, loop turns, and back to the cabinet termination.
 Loop #: The designation from the road plans.
 Lane #: Lane 1 is the right most lane in the direction of traffic, etc.
 Trailing Loop: The last loop that traffic goes over in that lane.

Loop Detector Test Acceptance Criteria	
Inductance (L): 120 – 150 μH	Loop Quality (Q): > 5
	Resistance (R): < 0.7Ω
	Meg-Ohms: > 100

ITEM 853.8 TEMPORARY ILLUMINATION FOR WORK ZONE DAY

The work under this Item shall conform to the relevant provisions of Subsection 850 of the Standard Specifications and the following:

The work under this Item shall include furnishing, deploying, and maintaining in proper operating condition a LED balloon diffuser lighting system. These portable light towers shall be used throughout the project area for temporary work zone lighting. The use of unshielded high wattage flood lights shall not be permitted.

These towers shall be used, relocated, and adjusted to meet the criteria in Subsection 850 of the Standard Specifications and the following:

The Contractor shall illuminate the following work zone areas:

- Change in direction (i.e., work zone entrances and exits, crossovers, etc.)
- Tapered areas
- Actual area where the construction is being performed

Light measurement shall be based on the illuminance method and the lighting levels shall be based on the classification of construction activity that is taking place. At no time shall the light level be below 5 fc and the uniformity shall not exceed 6:1. Task Classifications and recommended illumination levels are shown in Table 1.

Task Classifications	Illumination Level	Average Minimum Maintained Illuminance
All work operations areas, setup of lane or road closures, lane closure tapers, and flagging stations such as Excavation (all types), Embankment Fill and Compaction, Reworking Shoulders, Asphalt Pavement Rolling, Subgrade, Stabilization and Construction, Base Course Rolling, Sweeping, Cleaning and Landscaping.	Level I	5 foot- candles
Areas on or around construction equipment, asphalt paving, milling, and concrete placement and/or removal such as Milling, Removal of Pavement, Asphalt Paving and Resurfacing, Concrete Pavement, Waterproofing and Sealing, Sidewalk Construction, Base Course Grading and Shaping, Surface Treatment, Bridge Decks, Drainage Structures and Drainage Piping, Other Concrete Structures, Barrier Wall and Traffic Separators, Guardrails and Fencing, Striping and Pavement Markings, Repair of Concrete Pavement, Highway Signs, Hole Filling and Repair of Guardrails and Fencing.	Level II	10 foot- candles
Pavement or structural crack/ pothole filling, joint repair, pavement patching and/or repairs, installation of signal/electrical/mechanical equipment such as Traffic Signals, Highway Lighting Systems and Crack Filling	Level III	20 foot- candles

TABLE 1 TASK CLASSIFICATIONS AND ILLUMINATION LEVELS

ITEM 853.8 (Continued)

Prior to commencement of work the Contractor shall submit to MassDOT for approval a description of illumination equipment that is proposed to be used on this project and shall include photometrics that detail the light levels that are to be provided for the particular operation for the type of equipment, level of luminance and height to be installed.

Any potential glare from the lighting system should be considered from each direction and on all approaching roadways and opposing lanes of traffic. Glare from the illumination system should be minimized as much as possible for both workers and motorists in adjacent active travel lanes. If necessary, the Contractor shall provide supplemental hardware such as, visors, louvers, shields, glare screen and barrier to reduce glare in adjacent active travel lanes.

Equipment mounted lighting may be used to supplement light towers to achieve the required lighting levels for the activity involved per Table 1.

METHOD OF MEASUREMENT AND BASIS OF PAYMENT

Item 853.8 will be measured and paid for at the contract unit price per Day according to Subsections 850.80 and 850.81 of the Standard Specifications. The cost shall include all labor, materials, equipment, tools, and all incidentals required for the design and installation of the work zone lighting system. This shall include, but not be limited to lighting submission preparation, wiring connections, equipment relocations, and include all material and labor incidental for a complete, functional, and operational work zone illumination system.

The price of this item shall include the material and labor necessary to install any supplemental hardware required to reduce glare on all adjacent active travel lanes.

The per Day (up to 24 hours) price shall be full compensation for all “Temporary Illumination for Work Zone” regardless of the number of concurrent work areas, amount of equipment concurrently in use or the durations of or changes of the work shifts per Day.

Furnishing, installing, resetting, modifying, and removing equipment for work zone illumination will be incidental to Item 853.8.

ITEM 854.6**TEMPORARY PORTABLE RUMBLE STRIP****DAY**

Work under this item consists of furnishing, deploying, maintaining in proper operating conditions, and removing temporary portable rumble strips (TPRS) for temporary lane closures of 24 hours or less.

MATERIALS

The TPRS shall be 10' to 11' wide, measured perpendicular to the path of travel, 12" to 16" long, measured parallel to the path of travel, and 0.5" to 0.75" tall. All edges shall be beveled. The surfaces shall be grooved to limit potential hydroplaning.

The TPRS shall lay flat on the road surface without the use of nails, anchors, or adhesives, and shall be flexible so as to conform to the surface profile.

The TPRS shall be able to withstand vehicle weights of up to 80,000 lbs. and operate in temperatures between 0° to 120° F.

The manufacturer shall certify the TPRS to be safe for use on roads with speed limits of at least 70 mph.

TPRS that appear damaged or functioning in an unsafe manner may be order removed by the Engineer and replaced at no additional cost.

CONSTRUCTION METHODS

The TPRS shall be installed per the plans or at the discretion of the Engineer.

The Contractor shall conform to the manufacturer's specifications for installation and the following:

- A. The road surface shall be cleared of all gravel, sand, and debris.
- B. If RoadQuake 2TM model is used, the modular pieces shall be assembled into 11-foot strips per the manufacturer's instructions in advance of deployment. The interconnected segments shall form a smooth and flat, continuous section.
- C. A Truck-Mounted Attenuator, conforming to Section 850, shall be used as shadow vehicle protection during the deployment and removal of TPRS on any roadway with speeds of 45 mph or greater.
- D. TPRS shall be deployed in conjunction with all other temporary traffic control devices. MA-W28-1 (Rumble Strips Ahead) sign(s) shall be installed per the Temporary Traffic Control Plan.

ITEM 854.6 (Continued)

E. TPRS deployment:

1. TPRS shall be placed perpendicular to the direction of travel, centered in the lane.
2. Three (3) individual strips are required for a single array.
3. Refer to the Temporary Traffic Control Plan for the location of the array respective to the lane closure.
4. The spacing of the individual strips within the array shall conform to the following table:

Speed Limit	Distance Between Rumble Strips (measured center-to-center)
>55 mph	20 feet
40 mph to 55 mph	15 feet
<40 mph	10 feet

5. The TPRS shall be placed without the use of nails, adhesives, or other methods of affixing them to the road surface.

F. All TPRS shall be maintained in proper condition, alignment, spacing, and location throughout the duration of the lane closure, at no additional cost.

G. The TPRS shall be removed prior to the removal of the traffic control devices used to close the travel lane.

H. TPRS shall not be used during snow events.

METHOD OF MEASUREMENT

An array of three (3) temporary portable rumble strips is considered one (1) unit and will be measured by the day. Each period of up to 24 hours during which this unit is in use will be measured as one day regardless of the number of times the array is deployed, repositioned, or removed.

BASIS OF PAYMENT

Temporary Portable Rumble Strips will be paid for at the contract unit price per day, which shall include full compensation for furnishing, deploying, repositioning, and removing the array of three (3) individual strips as directed by the Engineer.

ITEM 856.11**PORTABLE SPEED FEEDBACK SIGN****DAY**

The work under this item shall conform to the relevant provisions of Section 800 of the Standard Specifications, the Sketches, and the following:

The work shall include furnishing, deploying, and removing a solar powered portable speed feedback sign at various locations, as shown in the Sketches or as directed by the Engineer, throughout the duration of the contract.

Materials

The portable speed feedback sign shall, at a minimum, consist of the following items:

- A trailer or portable stand that includes leveling devices to ensure the system is level and plumb when deployed;
- A changeable message sign (CMS) with amber or white LEDs on a black background capable of displaying at least two digits;
- A “YOUR SPEED” plaque mounted above the CMS;
- An R2-1 (SPEED LIMIT) sign that has numbers that can be adjusted by hand with a speed limit of 55 MPH;
- A G20-5aP “WORK ZONE” plaque mounted above the R2-1 sign;
- A radar unit capable of monitoring a minimum of two lanes simultaneously and be able to distinguish directionality.
- A solar panel assembly rated for 90 mph wind conditions;
- A locking enclosure to house batteries and, if necessary, a CPU; and
- All mounting and supporting hardware and wiring necessary to complete a working system.

The CMS shall have a minimum width of 36” and a minimum height of 36”. The characters displayed in the CMS shall have a minimum height of 26” and the sheeting shall be aluminum alloy, with a minimum thickness of 0.06”.

The CMS shall automatically adjust its brightness under varying light conditions to maintain legibility.

The flash rate of the CMS shall be between 50 and 60 times per minute. The illuminated period of each flash shall be 50% of the total cycle.

All signs shall be MUTCD-compliant. R2-1 signs and “YOUR SPEED” plaques shall have a black border and legend on a white background and G20-5aP plaques shall have a black border and legend on a fluorescent orange background. All sign sheeting materials shall be Type VIII or higher per ASTM D4956-13 and shall meet the requirements of Section M9.30.0. All signs shall be mounted on Type A aluminum per Subsection 828.42.

All R2-1 signs shall have a width of 36” and a height of 48”.

All G20-5aP plaques shall have a width of 36” and a height of 24”.

ITEM 856.11 (Continued)

The portable speed feedback sign shall have the ability to log and store vehicle counts and speeds, by direction, for a minimum of 15 days. This data shall be retrievable via USB, Bluetooth®, WiFi, or optional wireless modem. The option to log and store vehicle counts and speeds shall also be available when the CMS is in dark mode.

The control console shall be located on the back of the speed display box, inside a weatherproof compartment, behind a hinged control console door. The control console door shall have key-operated latches that lock the door when latched.

The solar panels and battery shall have a minimum operating temperature range of -40° to 122°F (-40° to 50°C).

The batteries shall have a capacity to allow up to 30 days of autonomy without sunlight and with varying ambient temperature and number of activations, while simultaneously collecting speed and count data.

The system shall consist of a 12-volt remote battery charger that plugs into a standard commercial power source to recharge batteries if battery voltage drops due to lack of sun for automated solar charging system. The remote charge shall be mounted inside the batter box, mounted to a divider panel on the opposite side from the batteries.

The radar detector head shall be located inside the display cabinet, centered at the top of the electronic display, allowing the sign display to be installed on either side of the road.

The radar shall be able to detect vehicle speeds from a minimum distance of 1,000 ft and shall be able to detect vehicle speeds ranging from 5 to 138 mph. The radar shall have an operating temperature ranging from -40° to 185°F (-40° to 85°C).

The Contractor shall provide shop drawings and calculations to confirm solar panel sizing and battery/solar energy storage will meet the functional requirements of the system.

Any proprietary software required for the programming and/or operation of the CMS or radar unit shall be included at no additional cost.

Construction Methods

No work shall commence until the shop drawings are approved.

The Contractor shall install and position the speed feedback sign as shown on the plans or as Directed by the Engineer. The portable speed feedback sign display shall be mounted such that it is legible from a minimum distance of ¼ mile and visible from a minimum distance of ½ mile. All display modules shall be mounted on rubber vibration-isolation mounts, decreasing risk of physical shock during transport and isolating characters from chassis ground.

ITEM 856.11 (Continued)

The Contractor shall be responsible for positioning the solar panel(s) in order to maximize efficiency and optimize battery strength. The solar panel(s) shall be mounted behind the signs, above the signs frame in a position that has no shadowing effect on any traffic-facing component.

The CMS shall remain dark when no vehicles are present.

On roads with a speed limit of 45 miles per hour or greater, the CMS shall operate as follows:

- For measured speeds more than 20 MPH below the speed limit, it shall remain dark.
- For measured speeds of 20 MPH below the speed limit up to equal to the speed limit, it shall display the measured speed as a steady number.
- For measured speeds 1-20 MPH above the speed limit, it shall display the measured speed as a flashing number.
- For measured speeds more than 20 MPH above the speed limit, the display shall revert to dark mode.

When the speed feedback sign is not in use, the CMS shall be dark and the R2-1 sign shall be covered, folded down, or otherwise turned away from approaching traffic.

METHOD OF MEASUREMENT

Item 856.11 will be measured for payment by DAY for each 24-hour period deployed and activated.

BASIS OF PAYMENT

Item 856.11 will be paid for at the contract unit price per DAY, which price shall include full compensation for furnishing, installing, relocating, and removing, including all labor, materials, signs, equipment, and incidental costs required to complete the work.

Temporary traffic control required for the installation, relocation, and removal of the portable speed feedback signs shall be paid for under their respective items.

No payment shall be made on any day the portable speed feedback sign is inoperable due to insufficient battery power or malfunctioning equipment.

ITEM 859.1 **REFLECTORIZED DRUMS WITH SEQUENTIAL** **DAY**
FLASHING WARNING LIGHTS

The work under this Item shall conform the relevant provisions of Subsection 850 of the Standard Specifications and the following:

Work under this item consists of furnishing, installing, maintaining in proper operating conditions, and removing reflectorized drums, and any necessary ballast, equipped with sequential flashing warning lights.

MATERIALS

Reflectorized drums shall be listed on the MassDOT Qualified Traffic Control Equipment List. Reflective sheeting on drums shall meet or exceed ASTM D4956 Type VIII. All drums shall be maintained in a satisfactory manner including the removal of oils, dirt, and debris that may cause reduced retroreflectivity.

The Contractor shall use one of the following sequential flashing warning light systems unless otherwise approved by the Engineer:

1. Empco-Lite LWCSO.
2. pi-Lit® Sequential Barricade-Style Lamp; or
3. Unipart Dorman SynchroGUIDE.

Sequential flashing warning lights shall be secured to reflectorized drums per the light manufacturer's specifications.

CONSTRUCTION METHODS

The first ten (10) drums in any merging or shifting taper as designated in the Temporary Traffic Control Plan shall be equipped with sequential flashing warning lights. These lights shall be operating, at a minimum, between dusk and dawn when the taper is deployed.

The successive flashing of the sequential warning lights shall occur from the upstream end of the merging or shifting taper to the downstream end of the taper in order to identify the desired vehicle path. Each warning light in the sequence shall be flashed at a rate of not less than 55, nor more than 75 times per minute.

Warning lights shall be powered off when drums are not deployed in a taper.

METHOD OF MEASUREMENT

A group of ten (10) reflectorized drums with sequential flashing warning lights is considered one (1) unit and will be measured by the day. Each period of up to 24 hours during which this unit is in use will be measured as one day regardless of the number of times that the drums are positioned, repositioned, removed, or returned to service.

ITEM 859.1 (Continued)

BASIS OF PAYMENT

Reflectorized Drums with Sequential Flashing Warning Lights will be paid for at the contract unit price per day, which shall include full compensation for furnishing, positioning, repositioning, and removing the group of ten (10) drums as directed by the Engineer.

<u>ITEM 862.506</u>	<u>FAST DRY MULTI-COMPONENT PAVEMENT MARKINGS, RECESSED, WET REFLECTIVE (6 INCH WHITE LINE)</u>	<u>FOOT</u>
<u>ITEM 862.512</u>	<u>FAST DRY MULTI-COMPONENT PAVEMENT MARKINGS, RECESSED, WET REFLECTIVE (12 INCH WHITE LINE)</u>	<u>FOOT</u>
<u>ITEM 862.524</u>	<u>FAST DRY MULTI-COMPONENT PAVEMENT MARKINGS, RECESSED, WET REFLECTIVE (24 INCH WHITE LINE)</u>	<u>FOOT</u>
<u>ITEM 863.506</u>	<u>FAST DRY MULTI-COMPONENT PAVEMENT MARKINGS, RECESSED, WET REFLECTIVE (6 INCH YELLOW LINE)</u>	<u>FOOT</u>

The work under these items shall conform to the relevant provisions of Subsection 860 of the Standard Specifications and the following:

The work shall consist of grooving a slot in the pavement surface and furnishing and installing Multi-Component Wet Reflective Pavement Markings at the locations shown on the Sketches or as directed by the Engineer.

Materials

Fast Dry Multi-Component Wet Reflective Pavement Markings shall consist of a liquid binder, first drop beads or elements to provide dry and wet retroreflectivity, and second drop glass beads to improve the durability of the pavement marking, reduce track-free times, and provide supplementary dry retroreflectivity. Multi-Component Pavement Marking binders are typically composed of, but not limited to, Epoxies, Polyureas, and Urethanes.

Classification of dry time is based upon the results of the test procedures found in ASTM D711 (73.5 ± 3.5°F at 50 ± 5% relative humidity) when applied with glass beads. Fast Dry Multi-Component Pavement Markings shall have a no track time of 10 minutes or less when tested under ASTM D711. The Contractor shall provide a Certificate of Compliance verifying the product supplied meets the specified dry time requirements per ASTM D711 prior to installation.

The Contractor shall select a liquid binder and bead/element combination that meets these performance specifications.

Second drop beads shall be manufactured from glass of a composition that is highly resistant to traffic wear and to the effects of weathering. If coating is required to meet the performance requirements, the second drop beads shall be coated to ensure satisfactory embedment and adhesion. Second drop beads retained on a No. 40 U.S. Standard Mesh Sieve shall have a minimum crush strength of 30 lbs. when tested in accordance with ASTM D1213.

Second drop beads passing the No. 30 sieve shall have a minimum of 75 percent true spheres when tested in accordance with ASTM D1155. All second drop beads retained on the No. 20 and No. 30 sieves shall have a minimum of 80 percent true spheres as determined by ASTM D1155.

ITEMS 862.506, 862.512, 862.524, AND 863.506 (Continued)

Second drop beads shall meet the following gradation requirements when tested in accordance with ASTM D1214:

U.S. Standard Sieve No.	Percent Retained
20	3-10
30	15-35
50	45-75
70	0-10
Pan	0-5

Construction Methods
Installation of the Groove

Prior to cutting out the grooves for all recessed lines, the Contractor shall use a chalk line or other suitable method to layout the proposed pavement markings on the surface course so that the Engineer can inspect the locations. Once the Engineer has inspected and approved the proposed striping layout, the grooves for the proposed pavement markings may be cut. No pavement grooving shall be done without the prior approval of the Engineer.

Groove position shall be a minimum of 4 inches from the edge of the pavement marking to any longitudinal pavement joints. The groove shall not be installed on bridge joints, on drainage structures, or in other areas identified by the Engineer. The groove shall not be installed continuously for intermittent pavement markings, but only where markings are to be applied.

The use of gang stacked diamond cutting blades to grind a smooth square slot is required for producing all grooves. The spacers between blade cuts shall be such that there will be less than a 10 mil rise in the finished groove between the blades. The acceptability of the surface texture will be determined by the Engineer.

The diamond grinder shall have an articulating head so that the slots are installed correctly on grades and super elevated sections.

Grooves that are ground deeper or wider than the specified allowable limits shall be repaired per the direction of the Engineer at no additional cost. Grooves that are ground too shallow, too narrow, or with unacceptable rises between blade cuts shall be reground to the correct size, depth, and surface finish at no additional cost. Slots ground out of alignment shall be patched using an approved method and materials.

Grooves shall be 1 inch \pm ¼ inch wider than the pavement marking material. Groove depth shall be 100 mils \pm 5 mils, unless otherwise approved by the Engineer. Depth shall be consistent across the full width of the groove. Depth plates shall be provided by the Contractor to the Engineer to assure that desired groove depth is achieved.

ITEMS 862.506, 862.512, 862.524, AND 863.506 (Continued)

Grooves shall be clean, dry and free of laitance, oil, dirt, grease, paint or other foreign contaminants. Shrouds and a vacuum apparatus shall be included as part of the grinder to remove larger pieces of pavement that are ground out. If water is used to clean the groove or the grooving process takes place during rainfall, a minimum of 24 hours of dry time is required prior to the placement of pavement markings.

After the depth, width, length, and surface condition has been approved by the Engineer, an air lance shall be used to remove fine particles from the groove. Air compressors shall initially be blown out away from the application area to prevent compressor condensation build-up from entering the groove. The Contractor shall prevent traffic from traversing the grooves and re-clean grooves, as necessary, prior to application of pavement markings at no additional cost to the Department.

All grooves must be given final approval by the Engineer prior to the placement of pavement markings.

Installation of Multi-Component Wet Reflective Pavement Markings

Installation of wet reflective polyurea pavement markings shall conform to the Manufacturer's specifications and the following:

Application rate for binder and all beads and elements shall consider final pavement surface composition and smoothness in advance of application to ensure proper wet film thickness and embedment of all beads and elements. The Contractor shall provide the Engineer with documentation from the Manufacturer with all recommended application rates in advance of any pavement marking installation.

The minimum uniform wet thickness for the multi-component binder shall be 25-30 mils. The line thickness shall be met across at least the middle $\frac{2}{3}$ of the pavement marking width. Depth plates shall be provided by the Contractor to the Engineer to assure that desired thickness is achieved.

The finished white color shall be free from tint, with good opacity and visibility under both daylight and artificial light. The finished yellow color shall be defined by Federal Test Standard 595 - Color Chip Number 13538, using Federal Test Standard 141 (Method 4252). The finished lines shall be uniform in color and have clean, well-defined edges.

First and second drop beads and/or elements shall be applied in a manner that does not induce rolling or bouncing, to ensure that exposed portions of beads are free of binder material. Beads and elements should be embedded in the binder to a depth of approximately 50% of their diameter.

Drop rate for first drop bead or element shall be per the Manufacturer's specifications. Drop rate for second drop glass bead shall be 6.4-10.2 lbs. per gallon.

Newly installed pavement markings shall be protected from tracking during the setting period per Subsection 860.63.

ITEMS 862.506, 862.512, 862.524, AND 863.506 (Continued)

Once the installed pavement markings have been open for traffic for a minimum of 48 hours, the Contractor shall perform retroreflectance readings per the measurement and sampling procedures contained in ASTM D7585 (Standard Practice for Evaluating Retroreflective Pavement Markings Using Portable Hand-Operated Instruments) using the Referee Evaluation Protocol found in section 6.4. The following tests shall be performed during the measurement and sampling process:

1. ASTM E1710 (*Standard Test Method for Measurement of Retroreflective Pavement Marking Materials with CEN-Prescribed Geometry Using a Portable Retroreflectometer*); and
2. ASTM E2177 (*Standard Test Method for Measuring the Coefficient of Retroreflected Luminance (R_L) of Pavement Markings in a Standard Condition of Wetness*).

The average initial retroreflectance readings shall exceed the following minimum values:

	*White Markings	*Yellow Markings
ASTM E1710 (Dry)	475 mcd/lux/m ²	375 mcd/lux/m ²
ASTM E2177 (Wet Recovery)	375 mcd/lux/m ²	300 mcd/lux/m ²

*Observation Angle = 1.05°, Entrance Angle = 88.8°

Pavement markings with measured average initial retroreflectance readings that do not meet the specified minimum values using the procedures outlined in subsection 6.4.5 of ASTM D7585 shall be removed by an approved method and reapplied at no additional cost, unless otherwise instructed by the Engineer.

METHOD OF MEASUREMENT AND BASIS OF PAYMENT

Items 862.506, 862.512, 862.524, and 863.506 will be measured respectively by the FOOT, complete in place, as specified under Subsection 860.80.

Items 862.506, 862.512, 862.524, and 863.506 will be paid for at the respective contract unit prices per FOOT. The contract prices shall include all material, labor, and equipment, and all incidental costs required to complete the work.

<u>ITEM 864.31</u>	<u>SLOTTED PAVEMENT MARKER ONE-WAY WHITE</u>	<u>EACH</u>
<u>ITEM 864.33</u>	<u>SLOTTED PAVEMENT MARKER TWO-WAY WHITE/RED</u>	<u>EACH</u>
<u>ITEM 864.34</u>	<u>SLOTTED PAVEMENT MARKER</u> <u>TWO-WAY YELLOW/RED</u>	<u>EACH</u>

The work under these items shall consist of furnishing and installing one-way white, two-way white/red, and two-way yellow/red slotted pavement markers in accordance with MassDOT Traffic Standard Drawings TR6.2 and TR.6.5 and Engineering Directive E-05-003.

Construction Methods

The work shall include cutting the tapered pavement slot to the dimensions shown on the typical details for the one-way or two-way markers, application of the manufacturer's recommended epoxy adhesive, and placing the reflectorized pavement marker in the proper position within the slot so that the reflective face is visible and perpendicular to oncoming traffic and so that the top of the marker is set 1/8± inch *below* the top of the adjacent pavement.

Surface preparation and installation shall be strictly in accordance with the manufacturer's instructions.

Materials

Reflectorized pavement markers shall be taken from the MassDOT Qualified Construction Materials List (QCML).

METHOD OF MEASUREMENT

Slotted pavement markers (one-way white, two-way white/red, and two-way yellow/red) will be measured for payment respectively by the unit Each, complete in place.

BASIS OF PAYMENT

Slotted pavement markers (one-way white, two-way white/red, and two-way yellow/red) will be paid for at the contract unit prices each under Items 864.31, 864.33, and 864.34 respectively, which prices shall include all labor, materials, equipment and incidental costs required to complete the work.

ITEM 874.41

TRAFFIC SIGN REMOVED AND DISCARDED

EACH

The work under this item shall conform to the relevant provisions of Subsection 828 of the *Standard Specifications* and the following:

The work shall consist of removing and discarding signs together with their supports, regardless of size of posts and number of panels. All materials removed and discarded under this Item shall become the property of the Contractor, who shall properly dispose of the same away from the project site with no additional compensation.

Any existing foundation or support which shall not be reused shall be excavated to at least two-feet (2') below existing grade. The resulting void shall be filled with suitable material. If directed by the Engineer, the Contractor shall apply loam and seed to the disturbed area.

METHOD OF MEASUREMENT

Item 874.41 will be measured for payment by the unit each. Multiple signs on one post assembly (single or double, such as a route marker and cardinal direction marker or a sign requiring a second graphic sign) shall be considered as one unit.

BASIS OF PAYMENT

Item 874.41 will be paid for at the Contract unit price each, which price shall include all labor, materials, equipment, and incidental costs required to complete the work.

No separate payments will be made for all excavation (including rock excavation), gravel backfill, compaction and restoration work but all costs in connection therewith will be included in the Contract unit price bid.

Loam borrow and Seeding as part of the restoration work will be paid for separately under Items 751. and 765. respectively.

ITEM 909.3**RAPID SETTING LOW PERMEABILITY
CONCRETE****CUBIC YARD**

The Work under this Item shall conform to the relevant provisions of Subsection 901 of the Standard Specifications and the following:

The work shall consist of the supplying, mixing, placing, and curing of rapid setting low permeability repair concrete for deck repairs.

MATERIALS

Materials shall be delivered to jobsite in original, unopened, undamaged containers that clearly show the manufacturer's name, product name, and batch number. Material shall be stored in a dry area off the ground, protected from rain, snow, and other sources of moisture. Material shall be protected from temperature extremes. Bulk sand and coarse aggregate shall be stored in a well-drained area on a clean, solid surface and materials shall be covered to prevent contamination with foreign matter.

The rapid setting low permeability concrete deck repair material shall comply with the following material and proportioning requirements:

Component	Value
Cement Content	559 Pounds Per Cubic Yard
Fly Ash – Class F (AASHTO M 295)	99 Pounds Per Cubic Yard
Coarse Aggregate 3/8" (AASHTO M 80)	1450 Pounds Per Cubic Yard
Fine Aggregate (ASTM C33)	1600 Pounds Per Cubic Yard
Retarder*	As Directed
Water (AASHTO T 26)	296 Pounds Per Cubic Yard

* An approved retarding admixture may be used to extend the setting time of the concrete when so directed by the Engineer at dosage rates recommended by the cement concrete deck repair material manufacturer. Retarding admixture proposed for use must be approved by the Engineer. Only Materials listed on the MassDOT Qualified Construction Materials List (QCML) may be used.

Modifications to the cement concrete mix design provided above must be submitted to the Engineer for approval. The cement concrete must satisfy all performance criteria and trial batch testing requirements to the satisfaction of the Engineer to be considered acceptable.

Acceptance of the concrete compressive strength will be based on the field cured cylinders achieving a minimum of 5000 psi at 7 days or earlier as cast and tested by MassDOT. Compressive strength testing of field cured cylinders cast and tested by MassDOT should achieve a minimum compressive strength of 4000 psi at 30 hours as a verification that the mix is on target to achieve the 7 day acceptance requirement.

ITEM 909.3 (Continued)**SURFACE PREPARATION**

Existing concrete surfaces to be in contact with the proposed deck repair concrete must be free of materials such as paint, oil, curing compound, bond breaker, etc., that will inhibit bonding. Existing concrete surfaces shall be hydroblasted with equipment that can remove asphaltic material, oils, dirt, rubber, curing compounds, paint carbonation, laitance, weak surface mortar, and other potentially detrimental materials, which may interfere with the bonding or curing of the proposed deck repair and overlayment concrete.

Retained reinforcing steel shall be cleaned by abrasive blasting or other mechanical means to achieve a white metal finish and coated with zinc rich primer conforming to MassDOT Spec M7.02. Deteriorated reinforcement shall be replaced as directed by the Engineer.

Existing concrete surfaces must be saturated prior to concrete placement using potable water. Standing water shall be removed from surfaces to achieve a Saturated Surface Dry (SSD) condition.

MIXING

Cement concrete mixes shall be batched using Mobile Concrete (volumetric) mixing equipment. The MassDOT Highway Division will only permit the use of Mobile Concrete Mixers when all the following procedures are adhered to.

Upon written request by a Contractor, the Director of Research and Materials may approve the use of concrete proportioned by a Mobile Concrete Mixer used for the purpose of mixing rapid setting low permeability deck repair concrete.

All cement concrete materials, concrete handling, placement, protection, curing, and finishing requirements of the *Standard Specifications for Highways and Bridges* shall apply. Mobile Concrete Mixers shall meet all the requirements of ASTM C685 and be currently registered with the Volumetric Mixer Manufacturers Bureau (VMMB).

Each Mobile Concrete Mixer used on MassDOT Highway Division projects shall be pre-qualified as follows: All Mobile Concrete Mixers are required to have a Quality System Manual (QSM) that conforms to the format outlined in AASHTO R-38 and that adequately addresses the information specified in AASHTO R-38. The QSM shall be approved by the Research & Materials Section annually. A copy of the approved QSM shall be kept with the Mobile Concrete Mixer and made available to the Engineer upon request. The Quality Control procedures for concrete production contained in the approved QSM shall be adhered to for all placements.

ITEM 909.3 (Continued)

The concrete mixing and delivery equipment shall be capable of mixing and delivering concrete to the placement location at rates that are sufficient to comply with the project's restrictive time constraints. Cement concrete shall be proportioned and mixed using self-contained, mobile, and continuously mixing equipment that meets the following requirements:

1. Use a self-propelled mixer that is capable of carrying sufficient unmixed, dry, bulk cement, sand, coarse aggregate, and water to produce at least 6 cubic yards of concrete on site.
2. Use a mixer that is capable of positive measurement of cement introduced into the mix as well as fine and coarse aggregate. Use a recording meter that is visible at all times and equipped with a ticket printout to indicate the quantity of cement and aggregate materials.
3. Calibrate the mixers to accurately proportion the specified mix. Prior to placing concrete, perform calibration and yield tests under the Engineer's supervision and in accordance with the Department's written instructions. Copies of these written instructions are available from the Research & Materials Section. Perform the calibration and yield tests using the material to be used on the project. Recalibrate the mixer after any major maintenance operation on the mixer, anytime the source of materials changes, or as directed. Furnish all materials and equipment necessary to perform the calibrations and yield tests.
4. Use a mixer that controls the flow of water into the mix. Measure the flow rate of water with a calibrated flow meter coordinated with both the cement and aggregate feeding mechanisms and the mixer. Adjust the flow rate, as necessary, to control the slump and ensure that the water-cement ratios are met. In addition to flow meters, use mixers with accumulative water meters capable of indicating the number of gallons, to the nearest 0.1 gallon, introduced into the mixer. Filter water with a suitable mesh filter before it flows through the accumulative water meters.
5. Use a mixer that has a minimum of two liquid admixture dispensers and is capable of dispensing the admixtures through a controlled flow meter in accordance with ASTM C685.
6. Calibrate the mixer to automatically proportion and blend all components of the indicated composition on a continuous or intermittent basis as the finishing operation requires. Provide a mixer that discharges mixed material through a conventional chute and is capable of spraying water over the placement width as it moves ahead to ensure that the surface to be overlaid is wet prior to receiving the concrete.
7. Mount a tachometer on the unit to indicate the drive shaft speed.

ITEM 909.3 (Continued)Mix Design Requirements

Performance Criteria	
ASTM C191 Set Time (Mod)	
Initial Set	30 minutes
Final Set	40 minutes
Slump of Concrete	7 to 9 inches
Air Content	3% to 7%
Compressive Strength	
4 hours	2500 psi Minimum
7 days	5000 psi Minimum
Bond Strength (ASTM C882)	
24 hours	1200 psi Minimum
7 days	1900 psi Minimum
28 days	2200 psi Minimum
Chloride Penetration (ASTM C1202)	
90 days	1500 Coulomb Maximum
Shrinkage (ASTM C157)	
28 days	0.04% Maximum
Freeze – Thaw Durability (ASTM C666)	
300 cycles (Durability Factor)	80 Minimum
Unit Weight	150 pcf

The concrete mix design shall be mitigated per Subsection M4.02.00. Proposed mix design with data sheets and trial batches shall be submitted to the Research and Materials Section for review and approval. The Engineer shall be notified at least 48 hours prior to the test batching and shall be present to witness the testing.

All tests necessary to demonstrate the adequacy of the concrete mix shall be performed by the Contractor, including but not limited to: slump, air content, temperature, initial set and final set (AASHTO T197). Compressive strength tests shall be determined on field cured cylinders (4" X 8" cylinders) (a minimum of 9 sets of 3 cylinders=27 total) at 3 hours, 4 hours, 5 hours, 6 hours, 24 hours, approximately 30 hours, 2 days, 3 days, and standard cured cylinders at 7 days, and additional cylinders as needed.

ITEM 909.3 (Continued)

Compressive strength results of Standard and Field cured trial batch cylinders shall meet all the following minimum overdesign strength requirements in order to be considered acceptable. Compressive strength results shall be the average of three (3) 4" x 8" cylinders:

4 hour cylinders:	3,000 psi
30 hour cylinders:	5,000 psi
7 day cylinders:	6,000 psi

Research & Materials Section personnel will witness calibration or verification of equipment and prequalification sampling and testing of concrete ingredients performed for each Mobile Concrete Mixer. Concrete mix design and trial batches shall be preapproved by the Research & Materials Section.

For any project where a Mobile Concrete Mixer is proposed to be used, the Contractor must prepare and submit a project-specific construction Quality Control Plan (QC Plan). The QC Plan shall conform to the format and content detailed in the Northeast Transportation Training and Certification Program (NETTCP) Model QC Plan (December 2009, or latest edition).

Information contained in relevant sections of the approved QSM for the proposed Mobile Concrete Mixer may be referenced, rather than repeated, in applicable sections of the QC Plan (e.g., Materials Control, Production Facilities). The QC Plan shall be submitted to the Engineer a minimum of 30 days prior to proposed placement of concrete by Mobile Concrete Mixer. The District Construction Engineer and the Research & Materials Section will review the QC Plan. The Contractor shall not place any concrete by Mobile Concrete Mixer prior to approval by the Research & Materials Section.

A signed batch ticket printout from the printer mounted on the Mobile Concrete Mixer truck indicating that the mix batched is in conformance with the mix design previously approved shall also be provided to the Engineer prior to discharging concrete. The batch ticket shall record the actual water/cement ratio.

Quality Control inspection, sampling and testing, including but not limited to slump, air content, temperature and cylinders for compressive strength, shall be performed by the Contractor in accordance with the approved QC Plan. The Engineer will perform Acceptance sampling (every 50 cubic yards per day per approved truck) and testing for field cured cylinders as well as Acceptance inspection for materials and workmanship attributes.

The use of Item 909.3 is prohibited when the ambient temperature is expected to drop below 40° F within 7 days prior to the anticipated concrete placement. The Engineer may suspend or revoke approval of the Mobile Concrete Mixer at any time the unit fails to produce uniformly mixed concrete within the quality limits specified.

Material to be mixed should have a temperature of about 70°F. Warmer material will set faster than expected and cooler material will have slower strength gain. The temperature of the mixed concrete shall be controlled by protecting the bags of repair material from temperature extremes and by adjusting the temperature of the mixing water.

ITEM 909.3 (Continued)

The coarse aggregate shall be placed in the mixer followed by the mixing water, then the cement. The components shall then be mixed for 2 to 3 minutes to achieve a uniform lump-free consistency.

Admixtures not included as part of the approved mix design shall not be added without the approval of the Engineer. The repair concrete shall not be re-tempered. The concrete mixing and delivery equipment shall be capable of mixing and delivering concrete to the placement location at rates that are sufficient to avoid horizontal cold joints between successive placements.

PLACEMENT AND FINISHING

The deck repair concrete shall be placed onto substrates that are Saturated, Surface Dry (SSD). The manufacturer's limitations on minimum surface and ambient temperatures shall be complied with.

Surfaces that are adjacent to the placement shall be protected with drop cloths, waterproof paper, or other means to maintain them free of material splashes, water, and debris.

The deck repair concrete shall be placed immediately after mixing and shall be worked firmly into sides and bottom of repair area to achieve good bond. The concrete placement shall start at one edge of the excavation and shall continue full depth with temporary vertical bulkheads, if needed, to ensure that horizontal cold joints do not occur between successive concrete placements.

Final finishing shall be performed as soon as possible after placement as there will be little or no bleed water.

BRIDGE DECK VIBRATION

At the direction of the Engineer, in order to minimize the effects of vibrations from vehicular traffic passing in adjacent lanes next to each placement, traffic should be slowed along the adjacent travel lanes and the placement of concrete overlay should be executed between the hours of lower traffic volumes, generally between 1:00 AM and 3:00 AM.

CURING

Water curing of the deck repair concrete shall start once the deck repair concrete begins to lose its moist sheen. Wet burlap shall be placed on the deck repair concrete and the burlap shall be kept continuously wet for a 3 hours period after final set. Application of an approved curing compound in lieu of the 3 hours wet burlap cure must be reviewed and approved by the Engineer.

CLEAN UP

The mixer shall be cleaned immediately after use or add mix water and begin mixing immediately for the next batch. Buildup of hardened repair material in the mixer shall not be allowed since this creates inefficient mixing and the heat generated accelerates later batches.

ITEM 909.3 (Continued)

METHOD OF MEASUREMENT

Item 909.3 will be measured for payment by the Cubic Yard of rapid setting low permeability concrete actually installed, complete in place.

BASIS OF PAYMENT

Item 909.3 will be paid for at the Contract unit price per Cubic Yard, which price shall include all labor, materials, equipment, tools, forms, field representative, and all incidental costs required to complete the work.

Payment for the excavation, removal, and disposal of all reinforced concrete for the repairs will be made as described in Items 127.1, 127.4, and 127.41.

Payment for installation of new reinforcing steel will be made, if required, under Item 910.1, Steel Reinforcement for Structures - Epoxy Coated.

ITEM 910.1

**STEEL REINFORCEMENT FOR
STRUCTURES – EPOXY COATED**

POUND

The work under this Item shall conform to the relevant Provisions of Subsection 901 of the Standard Specifications and the following:

All requirements of Subsection 901.62 Reinforcement shall be adhered to, including but not limited to lapping at splices and ties at every other intersection.

The Contractor may be required to submit for approval, detail plans and schedule of bar reinforcement. The Contractor will replace reinforcing bars as directed by the Engineer. Any reinforcing steel damaged by the Contractor's operations will be replaced by the Contractor at their own expense.

Steel reinforcement lapped splices shall only be permitted with the approval of the Engineer, provided the extent of the distressed concrete removed to the limits as approved by the Engineer allows for obtaining required lap lengths.

Epoxy coated steel reinforcement shall be listed on the Qualified Construction Materials List (QMCL).

The Contractor may be required to use standard non-epoxy coated (black bar) instead of epoxy coated bar as directed by the Engineer.

METHOD OF MEASUREMENT

Item 910.1 will be measured as specified under Subsection 901.80.

BASIS OF PAYMENT

Item 910.1 will be paid for as specified under Subsection 901.81.

Item 910.1 will be paid for at the contract unit price per Pound of only the steel reinforcing installed, complete in place. The unit bid price shall include all labor, equipment, materials and all incidental costs required to complete the work.

The use of non-epoxy coated black bar will be substituted with no additional compensation, as required by the Engineer.

ITEM 912.**DRILLING AND GROUTING DOWELS****EACH**

The work under this Item shall conform to the relevant provisions of Subsection 901 of the Standard Specifications and the following:

The work shall consist of drilling holes, furnishing, installing, and grouting of steel dowel reinforcement at the locations shown on the drawings or as required by the Engineer.

The dowel embedment must be adequate to fully develop 125% of the yield strength of the bar. The embedment length, the method and equipment used to drill the dowel holes, and the diameter of the drilled hole shall at a minimum conform to the recommendations of the manufacturer and be submitted to the Engineer for approval.

MATERIALS

The grout to be used for these dowels shall be selected from the MassDOT Qualified Construction Materials List for its specific application. Reinforcing steel dowels shall meet the requirements of AASHTO M31 Grade 60. All reinforcing steel dowels shall be epoxy coated in accordance with AASHTO M284. Reinforcing steel dowels shall be incidental to the work under this Item.

CONSTRUCTION METHODS

All dowel holes shall be air drilled provided that the minimum edge distance of 6 inches is observed. Should, in the Engineer's opinion, air drilling be inappropriate due to questionable strength of the existing /concrete or insufficient edge distance, the dowel holes shall be diamond core drilled. The inner surfaces of the diamond core drilled dowel hole's inner surfaces shall be subject to the approval of the Engineer. The diameter of the drilled dowel holes shall be in accordance with the recommendations of the grout manufacturer. The holes shall be blown clear of any debris and shall have the approval of the Engineer prior to the placement of any grout material. The drilling operation shall be performed without damage to any portion of the existing structure that is to remain in place. Any damage to any portion of the existing structure that is to remain in place shall be repaired to a condition equal to or better than that existing prior to the beginning of the Contractor's operations and shall be repaired at the Contractor's expense.

The Contractor shall strictly follow the recommendations of the manufacturer for mixing and placing the grout material prior to the placement of the dowel. The Contractor shall adhere to the recommendations of the manufacturer regarding minimum and maximum temperatures while placing the grout. Any excessive grout around the hole after placement of the dowel shall be struck off smooth while the grout is still fresh.

The Contractor shall perform on site a minimum of two (2) tests of the dowels for capacity in tension in each location or component. The test shall be performed in the presence of and to the satisfaction of the Engineer. The testing, including the necessary material and equipment to perform the test, is incidental to the work under this Item. The pullout force shall correspond to 90% of the yield strength of the bar. If the test bar pulls out or if the concrete utilized in the test shows signs of fracture, the Contractor shall adjust the hole diameter, embedment length, and/or grout material to meet this requirement.

ITEM 912. (Continued)

The method of applying the tension load to the dowels shall conform to ASTM E488. Details of the test procedure, materials, and equipment shall be submitted to the Engineer for review and approval prior to commencement of the test. Dowels shall not be ordered until the embedment lengths have been approved by the Engineer.

The Contractor shall arrange with the material's manufacturer or distributor to have the services of a competent field representative at the work site prior to any drilling of the proposed dowel holes to instruct the work crews in proper dowel installation procedures. The field representative shall remain at the job site after work commences and continue to instruct until the representative, the Contractor, and Engineer are satisfied that the crew has mastered the technique of installing the dowels successfully. The representative shall make periodic visits to the project as the work progresses and shall confer on each visit with the Contractor, Inspector and/or Engineer. The manufacturer's field representative must be fully qualified to perform the work and shall be subject to the approval of the Engineer.

METHOD OF MEASUREMENT

Item 912. will be measured for payment by the Each dowel installed, complete in place.

BASIS OF PAYMENT

Item 912. will be paid for at the Contract unit price per Each, which price shall include all labor, materials, equipment, furnishing dowels, drilling holes, grouting the dowels regardless of the diameter or depth of the hole, and all incidental costs required to complete the work.

The Contractor shall be completely responsible for the expense of the service of the required field representative and the contract unit price shall be considered full compensation for all costs in connection therewith.

ITEM 973.1**PRE-COMPRESSED JOINT SEAL WITH
POLYURETHANE RESIN CONCRETE HEADERS****FOOT**

The work under this item shall consist of furnishing and installing a bridge joint system consisting of a pre-compressed joint seal and polyurethane resin concrete joint headers as shown on the contract drawings. This work differs from the requirements contained in Subsection 972 of the Standard Specifications as follows:

- A pre-compressed seal joint shall be used in place of the neoprene strip seal and steel extrusions;
- Polyurethane resin concrete with chopped fiberglass and sand aggregate shall be substituted for the elastomeric concrete that would otherwise conform to M4.07.0.

The work to be done under this item consists of constructing expansion dams and a pre-compressed seal bridge joint system. The dimensions for the dams and joint widths shall be as shown on the detail drawings or as directed by the Engineer.

Materials

The pre-compressed seal joint system assembly shall consist of a preformed/pre-compressed seal epoxy adhesive, injected silicone sealant bands, all combined in manner required by the manufacturer's specification and to form a continuous watertight seal.

The materials comprising the pre-compressed seal joint system shall be capable of accommodating minimum movements of +50%, -50% (Total 100%) of nominal material size. Depth and installation of seal shall be as recommended by manufacturer.

The preformed, pre-compressed, self-expanding, sealant system with silicon pre-coated surface shall be comprised of three components:

- 1) cellular polyurethane foam impregnated with hydrophobic 100% acrylic (to be certified in writing by independent laboratory tested FTIR and DSC analysis to be free in composition of any waxes or wax compounds), water based emulsion, factory coated with highway-grade, fuel resistant silicone;
- 2) field-applied epoxy adhesive primer;
- 3) field-injected silicone sealant bands.

Impregnation agent is to have proven non-migratory characteristics. Silicone coating to be highway-grade, low-modulus, fuel resistant silicone applied to the impregnated foam sealant at a width greater than maximum allowable joint extension and which when cured and compressed will form a bellow. Size of the seal shall be as recommended by manufacturer for the specific location and may vary along the length of the joint. The foam seal shall be installed into manufacturer's standard field-applied epoxy adhesive. The seal system is to be recessed from the deck surface such that after the field applied injection band of silicone is installed between the substrates and the foam, the highest part of the pre-applied silicone facing will be below the deck surface.

ITEM 973.1 (Continued)

Changes in plane and direction at locations, such as gutter line and face of barriers, shall be executed using factory-fabricated “universal 90” or custom transition assemblies supplied by the manufacturer of the pre-compressed seal. Transitions shall be warranted to be watertight at inside and outside corners through the full movement capabilities of the product.

The contractor shall certify in writing that the expansion joint seal system is capable of withstanding 150°F for three hours while compressed down to the minimum of movement capability dimension of the basis of design product (-50 percent of nominal material size) without evidence of any bleeding of impregnation medium from the material, and that the same material after the heat stability test will self-expand to the maximum of movement capability dimension of the basis-of-design product (+50 percent of nominal material size) within 24 hours at room temperature 68°F.

The Contractor shall submit measurements of the joint at a given temperature for the District Bridge Engineer to confirm the joint opening size is acceptable and does not need an adjustment.

All material for the pre-compressed joint seal system shall be stored indoors, in a dry area out of direct sunlight at room temperature.

The polyurethane resin concrete header material shall be comprised of a two-component polyurethane resin mixed with sand and chopped fiberglass aggregates. The sand imparts compressive strength. The fiberglass provides cross-linked reinforcement while, in combination with the sand, adds body to the polyurethane resin. The ratio of aggregate to resin by weight must not exceed 2. The aggregate shall be silica free, shall be furnished elastomeric concrete manufacturer, and shall meet the manufacturer’s specifications for the application. The mixed resin and aggregate shall provide the following properties:

Physical Property	Value (min.)	Test Method
Adhesion to Primed Concrete	413 PSI	ASTM D7234
Adhesion to Primed Steel	492 PSI	ASTM D7234
Adhesion to Primed Galvanized Steel	417 PSI	ASTM D7234
Tensile Strength Elongation	651 PSI 20%	ASTM D412 ASTM D412
Compressive Strength	1500 PSI	ASTM D695
Compressive Modulus	11.27 KSI	ASTM D695
Hardness (Shore D)	57	ASTM D2240
Hardness (Shore A)	98	ASTM D2240
Viscosity @ 50 RPM (Mixed Resin)	1560cP	ASTM D4847
Impact Testing– Drop**	No Failure @ 69°F No Failure @ -4°F	ASTM D3029-95

** 1-pound steel ball dropped onto 3/8” thick x 2¾” diameter disk from 17 feet.

ITEM 973.1 (Continued)**SUBMITTALS**

At least 30 days prior to start of the work, the Contractor shall submit to the Engineer for review and approval a detailed plan for the installation of the pre-compressed joint seal and modified elastomeric concrete joint headers. No work shall be performed until this submittal has been approved. The submittal shall include:

- A list of all manufactured materials and their properties to be incorporated in the joint system, including, but not limited to the pre-compressed joint seal and modified elastomeric concrete, as well as the aggregate source, type, gradation, aggregate to resin ratio by weight, and method of packaging.
- A detailed step by step installation procedure and a list of the specific equipment to be used for the installation. The plan must fully comply with the specifications and address all anticipated field conditions, including periods of inclement weather.

Materials Certificates and Certified Test Reports shall be submitted by the Contractor certifying that the pre-compressed joint seal and modified elastomeric concrete satisfies the specification requirements.

Construction

The pre-compressed seal profile shall be shipped to the job site in nominal 6.5 feet standard lengths in the manufacturer's standard shipping cartons. The seals shall be cut to length on the jobsite where required for straight lengths or directional change transitions. The appropriate tools, saws and miter boxes shall be utilized. All cuts shall be accurately measured and completed in a neat and workmanlike manner to ensure quality work.

The polyurethane resin header concrete must be installed on substrates that are thoroughly dried and the temperature must be at least 45°F and rising. The substrate surface shall be sound and free of any strength impairing defects before prepping. The entire surface onto which the polyurethane resin header concrete is to be applied shall be wire brushed and fully cleaned of all contaminants such as dirt, dust, oils, or other residue. The substrate shall be primed using the primer provided by the joint system manufacturer and shall be allowed to dry for 30 minutes prior to polyurethane resin header concrete. The polyurethane resin header concrete shall be placed into the forms where it will self-level and cure exothermically. Once cured, the surfaces of the polyurethane resin header concrete onto which the pre-compressed seal is to be bonded shall be abrasively blast and solvent cleaned so that the surface profile meets ICRI Concrete Surface Profile CSP 2 (minimum) or CSP 3 (preferred). The polyurethane resin header concrete shall cure sufficiently to be traffic ready in 2 hours or less. In no less than 1 hour, any forming materials used to cast the polyurethane resin header concrete may be removed for access for preparation of the substrate to accept the pre-compressed seal joint system.

Any required deck and/or joint header repairs must be fully cured and reach its design compressive strength prior to beginning joint installation. The Contractor shall produce uniform and parallel surfaces in the forming within the reinforced concrete deck slabs as detailed on the plans. The joint opening shall be protected by the Contractor to prevent any edge damage by any site equipment throughout the on-going construction process.

ITEM 973.1 (Continued)

Prior to installation of the pre-compressed seal, the joint opening shall be abrasive blast cleaned, blown clean using compressed air that is free of moisture and oil, and then solvent cleaned to remove any remaining dust or debris. The solvent used shall be either acetone or xylene. Water shall not be used as the solvent and only clean cloths shall be used. When the pre-compressed seal is used as the replacement seal for existing steel armored joint system, the joint opening and surfaces of the existing armored joint steel angles shall be abrasive blast cleaned to meet the requirements of SSPC SP-10 "Near White Metal". When the pre-compressed seal is to be attached to concrete surfaces, these surfaces shall be abrasive blast and solvent cleaned so that the surface profile meets ICRI CSP 2 (minimum) or CSP 3 (preferred). The depth of cleaning shall extend to the depth of the bottom of the pre-compressed seal material plus one inch (1") to remove any dust remaining. The joint gap shall be inspected for cleanliness by The Engineer. Should any contaminates remain, the joint must be re-cleaned.

The pre-compressed seal, epoxy adhesive, and injected silicone sealant band shall be installed in accordance with the Contract's drawings. The pre-compressed seal joint system shall be continuous through sidewalks, curbs, medians, and parapets as appropriate to the conditions at hand. The pre-compressed seal joint system shall terminate a minimum of six inches down the outside of parapet wall, if any. All terminating end pieces of the pre-compressed seal joint system shall be fully coated and capped with same silicone sealant used to manufacture the pre-compressed seal. Continuity of seal shall be achieved through the use of factory-fabricated universal or custom transitions supplied by the pre-compressed joint seal manufacturer. Changes in plane and direction at locations, such as gutter line and face of barriers, shall be executed using factory-fabricated "universal 90" or custom transition assemblies supplied by the manufacturer of the pre-compressed seal. Transitions shall be warranted to be watertight at inside and outside corners through the full movement capabilities of the product.

Pre-compressed Seal Manufacturer's Field Representative

1. The Contractor shall arrange with the pre-compressed seal joint system's manufacturer or distributor to have the services of a competent field representative at the work site prior to any installation to instruct the work crews in the proper installation procedures. The field representative shall remain at the job site after work commences and continue to instruct until the representative and the Contractor, Inspector and/or Engineer are satisfied that the crew has mastered the technique of installing the system successfully. The representative shall make periodic visits to the project as the work progresses and shall confer on each visit with the Contractor, Inspector and/or Engineer.
2. The manufacturer's field representative must be fully qualified to perform the work and shall be subject to the approval of the Engineer.
3. The Contractor shall be completely responsible for the expense of the service of the required field representative and the bid contract price shall be full compensation for all costs in connection therewith.

ITEM 973.1 (Continued)

METHOD OF MEASUREMENT

Item 973.1 will be measured for payment by Foot, measured along the joint centerline of pre-compressed joint seal with polyurethane resin concrete headers furnished and installed complete in place.

BASIS OF PAYMENT

Item 973.1 will be paid for at the contract unit price per Foot, which price shall include all labor, material, equipment, manufacturer's representative and all incidental costs required to completion of the work.

Any necessary removal of sections of thrie beam for seal installation will be incidental to Item 973.1.

The joint preparation and installation of pre-compressed seal at the parapets will be considered incidental to the work to be done under this item.

Removal of the existing joint and any reconstruction of the existing deck concrete beneath the joint headers will be paid for under Item 127.1.

ITEM 973.2**PRE-COMPRESSED JOINT SEAL****FOOT**

The work shall consist of furnishing and installing preformed, pre-compressed, self-expanding, sealant system with silicone pre-coated surface in retained armored joint systems.

The intent of this specification is to retain the components of the existing expansion joints to the maximum extent possible, and to replace only the existing seal.

The pre-compressed seal system shall be installed in parts- the bridge joint horizontal section, the curb unit section and the bridge parapet unit section.

All joint sealing material shall be capable of accommodating movements of +50%, -50% (100% Total) of nominal material size.

The preformed, pre-compressed, self-expanding, sealant system with silicone pre-coated surface shall be comprised of three components: 1) cellular polyurethane foam impregnated with hydrophobic 100% acrylic (to be certified in writing by independent laboratory tested FTIR and DSC analysis to be free in composition of any waxes or wax compounds), water based emulsion, factory coated with highway-grade, fuel resistant silicone; 2) field-applied epoxy adhesive primer; 3) field-injected silicone sealant bands. Impregnation agent is to have proven non-migratory characteristics. Silicone coating to be highway-grade, low-modulus, fuel resistant silicone applied to the impregnated foam sealant at a width greater than maximum allowable joint extension and which when cured and compressed will form a bellow. Size of the seal shall be as recommended by manufacturer for the specific location and may vary along the length of the joint. The foam seal shall be installed into manufacturer's standard field-applied epoxy adhesive. The seal system is to be recessed from the deck surface such that after the field applied injection band of silicone is installed between the substrates and the foam, the highest part of the pre-applied silicone facing will be below the deck surface as shown on the drawings.

Changes in plane and direction shall be executed using factory-fabricated or custom transition assemblies supplied by the same manufacturer of the preformed, pre-compressed, self-expanding, sealant system with silicone pre-coated surface. Transitions shall be warranted to be watertight at inside and outside corners through the full movement capabilities of the product.

Preparation of Area

The Contractor shall install the new seal in accordance with the seal manufacturer's latest instructions and specifications.

Construction Method

Prior to installation of the joint system, the joint opening should be blown clean using compressed air. The compressed air shall be free of moisture and oil. To ensure cleanliness, the joint walls shall be wiped clean with an approved solvent dampened, lint free rags, to the depth of the bottom of the pre-compressed seal material plus 1" to remove any dust remaining. The joint gap shall be inspected for cleanliness by The Engineer. Should any contaminates remain, the joint must be re-cleaned.

ITEM 973.2 (Continued)

The preformed, pre-compressed, self-expanding, sealant system with silicone pre-coated surface shall be continuous through parapets as appropriate to the conditions at hand. Continuity of seal shall be achieved through the use of factory-fabricated universal or custom transitions supplied by the preformed, pre-compressed, self-expanding, sealant system with silicone pre-coated surface joint seal manufacturer.

Manufacturer's Field Representative

1. The Contractor shall arrange with the preformed, pre-compressed, self-expanding, sealant system with silicone pre-coated surface joint's manufacturer or distributor to have the services of a competent field representative at the work site prior to any installation to instruct the work crews in the proper installation procedures. The field representative shall remain at the job site after work commences and continue to instruct until the representative and the Contractor, Inspector and/or Engineer are satisfied that the crew has mastered the technique of installing the system successfully. The representative shall make periodic visits to the project as the work progresses and shall confer on each visit with the Contractor, Inspector and/or Engineer.
2. The manufacturer's field representative must be fully qualified to perform the work and shall be subject to the approval of the Engineer.
3. The Contractor shall be completely responsible for the expense of the service of the required field representative and the bid contract price shall be full compensation for all costs in connection therewith.

Watertight Integrity Test

A watertight integrity test shall be required at each joint, as specified in Section 972.67

METHOD OF MEASUREMENT

Item 973.2 will be measured for payment by the Foot of pre-compressed joint seal furnished and installed as measured along the joint centerline and between curb lines and the parapet unit section complete in place.

BASIS OF PAYMENT

Item 973.2 will be paid for at the contract unit price per Foot, which price shall include all labor, material, equipment, manufacturer's representative, and all incidental costs required to complete the work.

The removal of the existing joint seal and preparation of the joint opening will be incidental to the work to be done under this item. No additional payment shall be made for the removal and reinstallation of highway guard for the installation of pre-compressed seals at parapets.

ITEM 994.1 **TEMPORARY PROTECTIVE SHIELDING** **SQUARE FOOT**

The work under this item consists of furnishing, installing, maintaining, removing and disposing of proposed shielding systems on and under bridge(s), in locations required by the Engineer.

The work under this Item shall provide for the protection of traffic, persons, and facilities on the roadway beneath bridges from falling debris during the removal of the unsound concrete from bridge decks, parapets, and copings.

No portion of the bridge deck shall be removed until the protective shielding is in place and complete.

Note that some of the bridges, due to their height (vertical clearance), may require special lifting equipment in order to place shielding for the assigned bridge repair work. Any equipment necessary to erect forms will be considered incidental to this item.

Any existing formwork on the bridge shall also be removed and disposed by the Contractor away from the job area, at no additional expense.

Any existing shielding on the bridge may be retained for the uses outlined in this Item so long as the relevant requirements listed below are met.

All shielding shall meet the following requirements:

1. Temporary Protective Shielding must be used on bridges over roadways, railroads, and waterways during full depth excavation and when, in the opinion of the Engineer, there is the possibility of dislodging concrete from the bottom of the deck, parapets or coping. In some cases, the Contractor may be able to utilize the bottom flanges of existing steel beams as supports for the protective shielding. However, the Contractor will not be permitted to weld onto, drill into, or cut any existing structural steel beams.
2. The Contractor shall submit drawings and calculations stamped by a Professional Engineer of the appropriate discipline registered in Massachusetts of the proposed temporary shielding to the Engineer for approval prior to its installation. The drawings shall include details of all connections, brackets, and fasteners. However, when the spacing between existing steel beams is 70 inches or less, the Contractor may utilize a wood plank shielding scheme.
3. Shielding shall be designed to safely withstand all loads that it will be subjected to. The allowable design stresses shall be in accordance with AASHTO Standard Specifications for Highway Bridges, 17th Edition. The design shall also include a description of the equipment and construction methods proposed for the deck, parapet, or coping excavation and the maximum size of the area being excavated. The shielding shall also be designed to withstand the maximum size of the excavated area should it fall during excavation or removal. No debris shall be swung over traffic, on or below the bridge.

ITEM 994.1 (Continued)

4. Shielding shall be designed such that impact on traffic during installation and removal shall be minimal. The Contractor shall submit the traffic plan to the Engineer for approval.

5. The shielding shall extend a sufficient distance above and beyond the deck overhang at the fascia where concrete excavation is required outside the fascia beams. The shielding shall extend the length of the damaged or distressed portion of the deck a length of sufficient distance to do the required deck demolition. Also, the width of shielding shall completely extend over the travel lanes and shoulders of the highway below and shall extend a minimum of one beam width in the transverse direction beyond the limits of the excavation.

6. The area for shielding shall be approved by the Engineer prior to any installation of any shielding. The Contractor may utilize the bottom flanges of existing beams as supports for the protective shielding. However, the Contractor will not be permitted to weld onto, drill into, or cut any existing structural steel beams. All spaces along the perimeter of the shielding and at the seams shall be sealed to prevent dust, water, and debris from escaping and falling onto traffic below the bridge.

7. The Engineer may request that the shielding be designed so that it may also serve as false work (forms) for all areas of full-depth concrete replacement/repair.

8. The shielding shall not decrease the minimum vertical bridge clearance to the roadway unless otherwise approved by the Engineer.

9. The shielding shall be maintained and remain in place until the strength of the concrete used to repair the deck has cured and reached the design strength requirement, except where shielding needs to be removed and reset to install formwork for the areas of full depth repair. The shielding shall remain the property of the Contractor and shall be removed by the Contractor from the site when no longer needed.

If the Contractor's operations damage any existing portions of the bridge that are to remain, such damage shall be repaired at the Contractor's own expense.

All materials used in the temporary shielding system shall become the property of the Contractor and shall be removed from the site upon the completion of the project.

METHOD OF MEASUREMENT

Item 994.1 will be measured for payment by the Square Foot of shielding installed, maintained, and removed upon completion of repair work as required by the Engineer.

BASIS OF PAYMENT

Item 994.1 will be paid for at the Contract unit price per Square Foot, which price shall include all labor, materials, equipment, removal and disposal all debris, shielding installation, maintenance, final removal upon completion of repair work, and all incidental costs required to complete the work.

ITEM 994.1 (Continued)

Payment of 60% of the Square Foot of this item will be made upon complete installation.
The remaining 40% of the Square Foot of this Item will be paid following complete removal.

Note: Temporary protective shielding has already been installed as a precautionary measure at several locations under the subject bridges. The existing shielding may be retained in lieu of installing new shielding under this Item so long as requirements one (1) through three (3) as listed previously in this Special Provision are met.

Engineering Services, when required, shall be incidental to this Item.

THIS PAGE IS INTENTIONALLY LEFT BLANK

DOCUMENT A00802

DETAIL SHEETS

THIS PAGE INTENTIONALLY LEFT BLANK

THE COMMONWEALTH OF MASSACHUSETTS
 MassDOT - HIGHWAY DIVISION
 TEN PARK PLAZA, BOSTON, MA

PRELIMINARY ESTIMATE OF QUANTITIES - DETAIL SHEETS

City/Town:	West Springfield/Chicopee	Year:	2024
STA.:	I-91 MM 8.52 to 10.50	Road:	Interstate 91
Type:	Maintenance and Related Work	Class:	Interstate
		Date:	December 6, 2024

Earth Excavation	220 CY	Pavement Milling Mulch	
Ordinary Borrow	5 CY	For Shoulders	60 TON

PAVEMENT NOTES

**PROPOSED PAVEMENT FINE MILLING AND PAVEMENT OVERLAY –
 INTERSTATE 91 TRAVEL LANES AND SHOULDERS**

AREA = 98,927± SY

SURFACE: 1.5 INCHES SUPERPAVE HIGH PERFORMANCE SURFACE
 COURSE 12.5 (HP – 12.5) OVER

FINE MILLING: 1.5 INCHES PAVEMENT FINE MILLING

ASPHALT EMULSION FOR TACK COAT SHALL BE APPLIED AT 0.07 TO 0.09 GAL/SY
 OVER FINE MILLED SURFACE

NOTE: -ALL EXISTING CONCRETE RUMBLE AREAS AT RAMP GORES SHALL BE
 RETAINED.
 -THE CONTRACTOR SHALL RESTORE ANY MILLING MULCH FOR
 SHOULDERS WHICH WAS DISTURBED DURING CONSTRUCTION WITHIN
 TWO WEEKS OF FINAL PAVING TO ENSURE PROPER COUNTRY DRAINAGE.

**PROPOSED PAVEMENT FINE MILLING AND PAVEMENT OVERLAY –
 INTERCHANGE 10A AND 10B RAMPS**

AREA = 31,045± SY

SURFACE: 2.0 INCHES SUPERPAVE SURFACE COURSE – 12.5 POLYMER
 (SSC – 12.5 – P) OVER

FINE MILLING: 2.0 INCHES PAVEMENT FINE MILLING

ASPHALT EMULSION FOR TACK COAT SHALL BE APPLIED AT 0.07 TO 0.09 GAL/SY
 OVER FINE MILLED SURFACE

**PROPOSED BRIDGE PAVEMENT REMOVAL AND SURFACE COURSE
RESURFACING (BRIDGES W-21-045, W-21-046, W-21-047)**

AREA = 2,895 ± SY

SURFACE: 2.50 INCHES SUPERPAVE WATERPROOFING SURFACE
COURSE – 12.5 (SSC-W-12.5) (1 LIFT) OVER

BRIDGE PAVEMENT REMOVAL: ALL HMA (APPROXIMATELY 2.50 INCHES) AND ALL
EXISTING BRIDGE MEMBRANE REMOVAL
(AT BRIDGE DECKS)

ASPHALT EMULSION FOR TACK COAT SHALL BE APPLIED AT 0.06 TO 0.08 GAL/SY
OVER BRIDGE DECK.

NOTE: BRIDGE WATERPROOFING MEMBRANE SHALL NOT BE INSTALLED ON
BRIDGES

**PROPOSED BRIDGE PAVEMENT MILLING AND SURFACE COURSE
RESURFACING (BRIDGE C-13-034 = W-21-043)**

AREA = 14,445 ± SY

SURFACE: 2.00 INCHES SUPERPAVE WATERPROOFING SURFACE
COURSE – 12.5 (SSC-W-12.5) (1 LIFT) OVER

BRIDGE PAVEMENT MILLING: 2.00 INCHES BRIDGE PAVEMENT MILLING
(APPROXIMATELY 1" OF EXISTING PAVEMENT WILL BE
RETAINED)

ASPHALT EMULSION FOR TACK COAT SHALL BE APPLIED AT 0.07 TO 0.09 GAL/SY
OVER THE MILLED SURFACE.

ITEM 101.1 **CLEARING**

Contingency to clear vegetation from roadsides per Contract Sketches.

ITEM 102.1 **TREE TRIMMING**

To trim trees along the roadway, as shown in the Contract Sketches.

No tree trimming shall be performed in vegetated wetlands buffer zones at the following locations unless guardrail is present, in which case trimming shall not be performed more than six feet beyond the back of the guardrail:

MM 8.70 – MM 8.75: I-91 NB & SB

MM 9.30 – MM 9.40: I-91 NB

MM 9.85 – MM 10.00: I-91 NB & SB

MM 10.05 – MM 10.20: I-91 NB

Along ramps of Interchange 10B between MM 9.30 to MM 9.50

ITEM 106.15 **BLEEDER (BRIDGE DECK) PVC**

Contingency to replace damaged PVC bleeder assemblies.

ITEM 106.151 **PVC DRAIN PIPE EXTENSIONS**

Contingency to replace broken or missing PVC bleeder extensions.

ITEM 120. **EARTH EXCAVATION**

To remove sediment buildup along shoulders of road to restore country drainage as required by the Engineer. To excavate for gravel base and berm pad under HMA berm proposed in Item 470. To excavate for reconstruction of pedestrian curb ramps.

ITEM 127.1 **REINFORCED CONCRETE EXCAVATION**

To excavate unsound concrete within three feet of a joint on bridges W-21-045, W-21-046, and W-21-047. To excavate and discard angle-type armored joints on C-13-034 as noted in the Contract Sketches and as listed below:

- East abutment Northbound and Southbound
- West abutment Northbound and Southbound
- Pier 1 Northbound
- Pier 7 southbound

Note: all finger joints shall be retained on C-13-034.

ITEM 127.4 **REINFORCED CONCRETE DECK EXCAVATION (FULL DEPTH)**
ITEM 127.41 **REINFORCED CONCRETE DECK EXCAVATION (PARTIAL DEPTH)**

To excavate deteriorated concrete on the decks of bridges W-21-045, W-21-046, and W-21-047.

ITEM 129.6 **BRIDGE PAVEMENT EXCAVATION**

To remove all existing pavement and waterproofing membrane on bridges W-21-045, W-21-046, W-21-047.

ITEM 141. **CLASS A TRENCH EXCAVATION**

To excavate for the installation of perpendicular HMA waterways along proposed berm on the northbound outside shoulder of I-91 between MM 9.68 and MM 9.87. See Sketches and Item 470.

ITEM 150. **ORDINARY BORROW**

Contingency to be used after all material suitable for reuse excavated under Item 120. has been reused to build up existing fore slope adjacent to proposed HMA berm described under Item 470. prior to placing loam and seed.

ITEM 151. **GRAVEL BORROW**

To use as sub-base under proposed HMA berm described under Item 470. if unsuitable material is found during excavation and contingency if existing gravel borrow underneath the proposed pedestrian curb ramps is unsuitable for reuse.

ITEM 170. **FINE GRADING AND COMPACTING – SUBGRADE AREA**

To fine grade and compact subgrade under gravel borrow proposed in Item 151. and in areas where gravel borrow is being retained during excavation.

ITEM 180.01 **ENVIRONMENTAL HEALTH AND SAFETY PROGRAM**

For proposed environmental health and safety program to ensure the health and safety of the contractor's employees, subcontractors, the engineer, their representatives, the environment and the public from any on-site chemical contamination present in the air, soil, water and sediment.

ITEM 180.02 **PERSONAL PROTECTION LEVEL C UPGRADE**

Contingency to provide appropriate personal protective equipment (PPE) for all personnel in an area either containing or suspected of containing a hazardous environment.

ITEM 180.03 **LICENSED SITE PROFESSIONAL SERVICES**

For a Licensed Site Professional (LSP) to provide the services necessary to comply with the requirements of the Massachusetts Contingency Plan (MCP).

ITEM 181.11 **DISPOSAL OF UNREGULATED SOIL**

Contingency Item to transport and dispose of any contaminated excavated or excavated and stockpiled soil characterized as unregulated and for other related disposal requirements of the disposal facility.

ITEM 181.12 **DISPOSAL OF REGULATED SOIL – IN-STATE FACILITY**

Contingency Item to transport and dispose of any contaminated excavated or excavated and stockpiled soil characterized as regulated, to an in-state facility and for other related disposal requirements of the in-state disposal facility.

ITEM 181.13 **DISPOSAL OF REGULATED SOIL – OUT-OF-STATE FACILITY**

Contingency Item to transport and dispose of any contaminated excavated or excavated and stockpiled soil characterized as regulated, to an out-of-state facility and for other related disposal requirements of the out-of-state disposal facility.

ITEM 181.14 **DISPOSAL OF HAZARDOUS WASTE**

Contingency Item to transport and dispose of any contaminated excavated or excavated and stockpiled soil characterized as hazardous waste and for other related disposal requirements of the disposal facility.

ITEM 184.1 **DISPOSAL OF TREATED WOOD PRODUCTS**

Contingency Item to dispose of any damaged wood block outs replaced under Item 626.322.

ITEM 220. **DRAINAGE STRUCTURE ADJUSTED**
ITEM 220.2 **DRAINAGE STRUCTURE REBUILT**

Adjust or rebuild all drainage structures within paving limits of the project.

ITEM 221.1 **FRAME AND COVER – SECURED**
ITEM 222. **FRAME AND GRATE – MASSDOT BAR TYPE**
ITEM 223.2 **FRAME AND GRATE (OR COVER) REMOVED AND DISCARDED**

Contingency to replace any damaged or non-locking catch basin grates or manhole covers.

ITEM 227.3 **REMOVAL OF DRAINAGE STRUCTURE SEDIMENT**
ITEM 227.31 **REMOVAL OF DRAINAGE PIPE SEDIMENT**

To remove and dispose of sediment and debris from drainage structures (including bridge scuppers) and drainage pipes within the project limits as required by the Engineer.

ITEM 280. **HOT MIX ASPHALT WATERWAY**

To install paved waterways every 250' perpendicular the outside shoulder of I-91 NB between MM 9.68 and MM 9.87 to convey runoff from proposed berm to the existing paved waterway approximately 15 feet from edge of pavement. See Item 470. and Contract Sketches.

ITEM 280.2 **CLEANING PAVED WATERWAYS**

To remove and dispose of debris, sediment, and overgrown vegetation from paved waterway at locations determined by the Engineer.

ITEM 402.14 **PAVEMENT MILLING MULCH FOR SHOULDERS**

For proposed milling mulch to fill low, eroded areas along the edge of the road without curb or berm, including under retained guardrail, to maintain country drainage as required by the Engineer.

ITEM 415.2 **PAVEMENT FINE MILLING**

To mill 1.5" from Interstate 91 mainline from MM 8.518 to MM 10.504 and 2.0" from ramps 10A and 10B.

ITEM 415.4 **BRIDGE PAVEMENT MILLING**

To mill 2.00 inches of pavement from the surface of bridge C-13-034. Note: Approximately 1 inch of pavement will be retained on C-13-034.

ITEM 450.231 **SUPERPAVE SURFACE COURSE – 12.5 POLYMER (SSC-12.5-P)**

For paving 2.0” of HMA on interchanges 10A and 10B ramps.

ITEM 451. **HMA FOR PATCHING**

To install berm pad under berm proposed in Item 470. To patch significantly distressed and unsound areas of HMA in the milled pavement where required by the Engineer.

ITEM 457.2 **SUPERPAVE WATERPROOFING SURFACE COURSE – 12.5(SSC-W-12.5)**

To pave the decks of bridges C-13-034, W-21-045, W-21-046, and W-21-047. To pave bridge approaches 10 feet beyond bridge joint as shown in the Bridge Deck Plans. To pave bridge approach on the east side of bridge C-13-034 between the abutment joint and the existing pavement joint approximate 40 feet from the abutment joint.

ITEM 458.2 **SUPERPAVE HIGH PERFORMANCE SURFACE COURSE 12.5 (HP-12.5)**

For paving 1.5” of HMA on Interstate 91 mainline, excluding ramps and bridges.

ITEM 470. **HOT MIX ASPHALT BERM**

To install new HMA berm along the outside edge of I-91 NB from MM 9.68 to 9.87 in place of the existing HMA patching. Berm shall be installed along the edge of paved shoulder from the existing guardrail end treatment at MM 9.68 to 1000 feet north, terminating at MM 9.87. All existing HMA patching beyond the normal paved shoulder in this location shall be removed prior to installation of HMA berm. Perpendicular waterways allowing the transfer of water to the existing paved waterway approximately 15 feet from edge of pavement shall be constructed every 250 feet. See Contract Sketch.

ITEM 472. **TEMPORARY ASPHALT PATCHING**

For temporary ramps to transition between surface course and milled surface, temporary patching around structures, emergency pothole repair on the roadway, and elsewhere as required.

ITEM 477. **MILLED RUMBLE STRIP (TYPE A)**

To install milled rumble strips per MassDOT Engineering Directive E-20-007. Rumble strip at painted interchange gore areas shall be installed according to MassDOT Standard Drawing E105.3.2. Do not install rumble strip adjacent to concrete gore areas.

ITEM 482.31 **SAWING AND SEALING JOINTS IN ASPHALT PAVEMENT AT BRIDGES**

To replace existing saw and seal joints at the following locations:

- W-21-045: East abutment
- W-21-046: East abutment
- W-21-047: East and west abutments

To install saw and seal joints over pre-compressed seals at the following locations:

- W-21-045: West abutment
- W-21-046: West abutment

ITEM 504. **GRANITE CURB TYPE VA4 – STRAIGHT**

Contingency to replace damaged curb as required by the Engineer.

ITEM 511.1 **GRANITE EDGING TYPE SB – STRAIGHT**

Contingency to replace damaged edging as required by the Engineer.

ITEM 580. **CURB REMOVED AND RESET**
ITEM 583. **EDGING REMOVED AND RESET**

Contingency to remove and reset curb or edging as required by the Engineer.

ITEM 594. **CURB REMOVED AND DISCARDED**
ITEM 597. **EDGING REMOVED AND DISCARDED**

Contingency to remove and discard curb or edging replaced under Items 504. And 511.1.

ITEM 620.13 **GUARDRAIL, TL-3(SINGLE FACED)**

To replace sections of damaged guardrail greater than 150 feet in length at locations required by the Engineer. To install a single panel with Item 628.21 in accordance with MassDOT Construction Details Standard Drawing 400.3.1 as required. Damaged sections of guardrail less than 150 feet in length shall be replaced in kind under Items 632.–634.1.

ITEM 626.321 **MAINTENANCE OF STEEL THRIE BEAM BRIDGE RAIL RETROFIT**

ITEM 626.322 **BRIDGE RAIL RETROFIT BLOCK OUT REPLACEMENT**

To inspect existing thrie beam bridge rail, tighten all loose bolts, replace damaged or missing bolts, and replace damaged or missing block outs on the parapet walls of W-21-045, W-21-046, and W-21-047.

ITEM 627.1 **TRAILING ANCHORAGE**

To replace terminal ends with trailing anchorages at the following locations:

<u>Location</u>	<u>MM</u>	<u>Side</u>
I-91 SB	9.9	RT
I-91 SB	10.45	RT
I-91 SB	10.45	LT

ITEM 627.83 **GUARDRAIL TANGENT END TREATMENT, TL-3**

To replace Tangent End Treatment at the following location and elsewhere as required by the Engineer:

<u>Mile Marker</u>	<u>Location</u>	<u>Direction</u>	<u>Side</u>	<u>Quantity</u>
MM 10.06	I-91	SB	RT	1

ITEM 628.21 **TRANSITION TO NCHRP 350 GUARDRAIL**

To connect existing guardrail to new TL-3 guardrail components such as proposed end treatments and trailing anchorages where required per MassDOT Construction Standard Drawing 400.3.1.

ITEM 628.25 **TRANSITION TO THRIE BEAM**

To connect existing thrie beam guardrail to new W-Beam style trailing anchorage in the high speed shoulder at MM 10.45 southbound.

ITEM 630.2 **HIGHWAY GUARD REMOVED AND DISCARDED**

To remove and discard any existing highway guard being replaced within project limits.

ITEM 632. **GUARDRAIL POST – STEEL**
ITEM 633. **GUARDRAIL OFFSET BLOCK - W BEAM**
ITEM 633.1 **GUARDRAIL OFFSET BLOCK - THRIE BEAM**
ITEM 634. **W BEAM GUARD PANEL**
ITEM 634.1 **THRIE BEAM GUARD PANEL**

To replace damaged guardrail components in kind for guardrail sections less than 150 feet in length. Guardrail sections greater than 150 feet in length shall be replaced with Item 620.13.

ITEM 701.2 **CEMENT CONCRETE PEDESTRIAN CURB RAMP**

To rebuild the following pedestrian curb ramps that are not ADA compliant:

North side of SB Interchange 10A On Ramp (PED-5549)
North side of NB Interchange 10A Off Ramp (PED-12447)
South side of SB Interchange 10B Off Ramp (PED-13928)

ITEM 751. **LOAM FOR ROADSIDES**
ITEM 765. **SEEDING**

To loam and/or seed along edge of proposed berm and paved waterway described under Item 470. and any disturbed areas as required by the Engineer.

ITEM 767.121 **SEDIMENT CONTROL BARRIER**

Install sediment control barrier along wetlands on the outside shoulder of I-91 NB between MM 9.9 and 10.2.

ITEM 769. **PAVEMENT MILLING MULCH UNDER GUARD RAIL**

Install pavement milling mulch under proposed guardrail, guardrail end treatments, trailing anchorages, and guardrail transitions.

ITEM 819.907 **INSTALL 3 LANE CLASSIFICATION TRAFFIC DATA STATION**

To install two new traffic data collection stations at the following locations as outlined in the Special Provisions:

- Latitude N42.142604, Longitude – W72.638492
- Latitude N42.141499, Longitude – W72.638179

ITEM 832. **WARNING-REGULATORY AND ROUTE MARKER – ALUMINUM PANEL (TYPE A)**

Contingency item to replace any faded, damaged, or missing signs within the project limits at locations required by the Engineer.

ITEM 833.5 **DEMOUNTABLE REFLECTORIZED DELINEATOR –GUARD RAIL**

Use to replace missing, damaged, or faded reflectORIZED delineators on retained guardrail.

ITEM 833.7 **DELINEATION FOR GUARD RAIL TERMINI**

Used to replace missing or damaged guardrail termini delineators.

ITEM 834. **DEMOUNTABLE REFLECTORIZED REFERENCE LOCATION SIGN**

Contingency to replace missing, damaged, or faded reference location signs within project limits.

ITEM 836.5 **DEMOUNTABLE REFLECTORIZED STATION MARKER**

Contingency to replace missing or damaged reflectORIZED station markers within project limits.

ITEM 847.1 **SIGN SUP (N/GUIDE)+RTE MKR W/1 BRKWAY POST ASSEMBLY- STEEL**
ITEM 848.1 **SIGN SUP (N/GUIDE)+RTE MKR W/2 BRKWAY POSTASSEMBLIES-STEEL**

Contingency to replace damaged or missing sign supports within the project limits in conjunction with Item 832. at locations determined by the Engineer.

ITEM 854.016 TEMPORARY PAVING MARKINGS - 6 INCH (PAINTED)

Use to reproduce existing pavement marking lines on milled surface throughout the project limits.

ITEM 854.036 TEMPORARY PAVING MARKINGS - 6 INCH (TAPE)

For use on surface course prior to final pavement marking installation. Install a 4 foot length of tape every 40 feet between all travel lanes.

ITEM 862.506 FAST DRY MULTI-COMPONENT PAVEMENT MARKINGS, RECESSED, WET REFLECTIVE (6" WHITE LINE)**ITEM 862.512 FAST DRY MULTI-COMPONENT PAVEMENT MARKINGS, RECESSED, WET REFLECTIVE (12" WHITE LINE)****ITEM 862.524 FAST DRY MULTI-COMPONENT PAVEMENT MARKINGS, RECESSED, WET REFLECTIVE (24" WHITE LINE)****ITEM 863.506 FAST DRY MULTI-COMPONENT PAVEMENT MARKINGS, RECESSED, WET REFLECTIVE (6" YELLOW LINE)**

Use to reproduce existing pavement markings on the surface course within the project limits in accordance with the Typical Sections. Additionally, install 6 inch dotted white line across interchange ramp openings along the mainline shoulder of I-91 and install 24 inch white gore lines, as shown on the Pavement Markings & Slotted Pavement Markers detail.

ITEM 864.04 PAVEMENT ARROWS AND LEGENDS REFLECTORIZED WHITE (THERMOPLASTIC)

Use to reproduce all existing pavement arrows and legends after the proposed surface course is paved on interchange ramps.

ITEM 874.41 TRAFFIC SIGN REMOVED AND DISCARDED

To remove and discard signs replaced under Item 832.

ITEM 905. 4,000 PSI, 3/8 INCH, 660 CEMENT CONCRETE

Contingency quantity to be used with bridge work at the discretion of the Engineer.

ITEM 909.3 **RAPID SETTING LOW PERMEABILITY CONCRETE**
ITEM 910.1 **STEEL REINFORCEMENT FOR STRUCTURES – EPOXY COATED**

For use on bridges W-21-045, W-21-046, and W-21-047 to replace concrete and steel reinforcement excavated under Items 127.1, 127.4, and 127.41 on deteriorated bridge decks. For armored joint replacement on C-13-034=W-21-043 and contingency to perform repairs on C-13-034=W-21-043 if significant deck deterioration is apparent through the milled surface after milling the bridge pavement.

ITEM 912. **DRILLING AND GROUTING DOWELS**

For contingency on bridges W-21-045, W-21-046, and W-21-047 when deteriorated reinforcement is encountered adjacent to parapet or bridge joints where the required reinforcement lap length cannot be achieved.

ITEM 973.1 **PRE-COMPRESSED JOINT SEAL WITH POLYURETHANE RESIN CONCRETE HEADERS**

To replace existing joints at the following locations:

Bridge No.	Location
W-21-047	Center Pier
C-13-034	SB East Abutment
C-13-034	SB Pier 7
C-13-034	SB West Abutment
C-13-034	NB East Abutment
C-13-034	NB Pier 1
C-13-034	NB West Abutment

ITEM 973.2 **PRE-COMPRESSED JOINT SEAL**

To install pre-compressed joint seals as shown in the Contract Sketches under sawcut joints on the west abutment of bridges W-21-045 and W-21-046.

To replace joint seals at locations where existing steel joint structure is undamaged and will be retained.

Bridge No.	Location	Length (FT)
C-13-034	NB Pier 7	49.00
C-13-034	SB Pier 1	49.00

ITEM 994.1

TEMPORARY PROTECTIVE SHIELDING

To be installed directly beneath any full depth bridge deck repairs on bridges W-21-045, W-21-046, and W-21-047, and as required by the Engineer. Existing shielding may be utilized beneath bridge deck repairs if appropriate engineering calculations are provided by the contractor as outlined in the Special Provision.

DOCUMENT A00803

DRAWINGS AND SKETCHES

THIS PAGE INTENTIONALLY LEFT BLANK

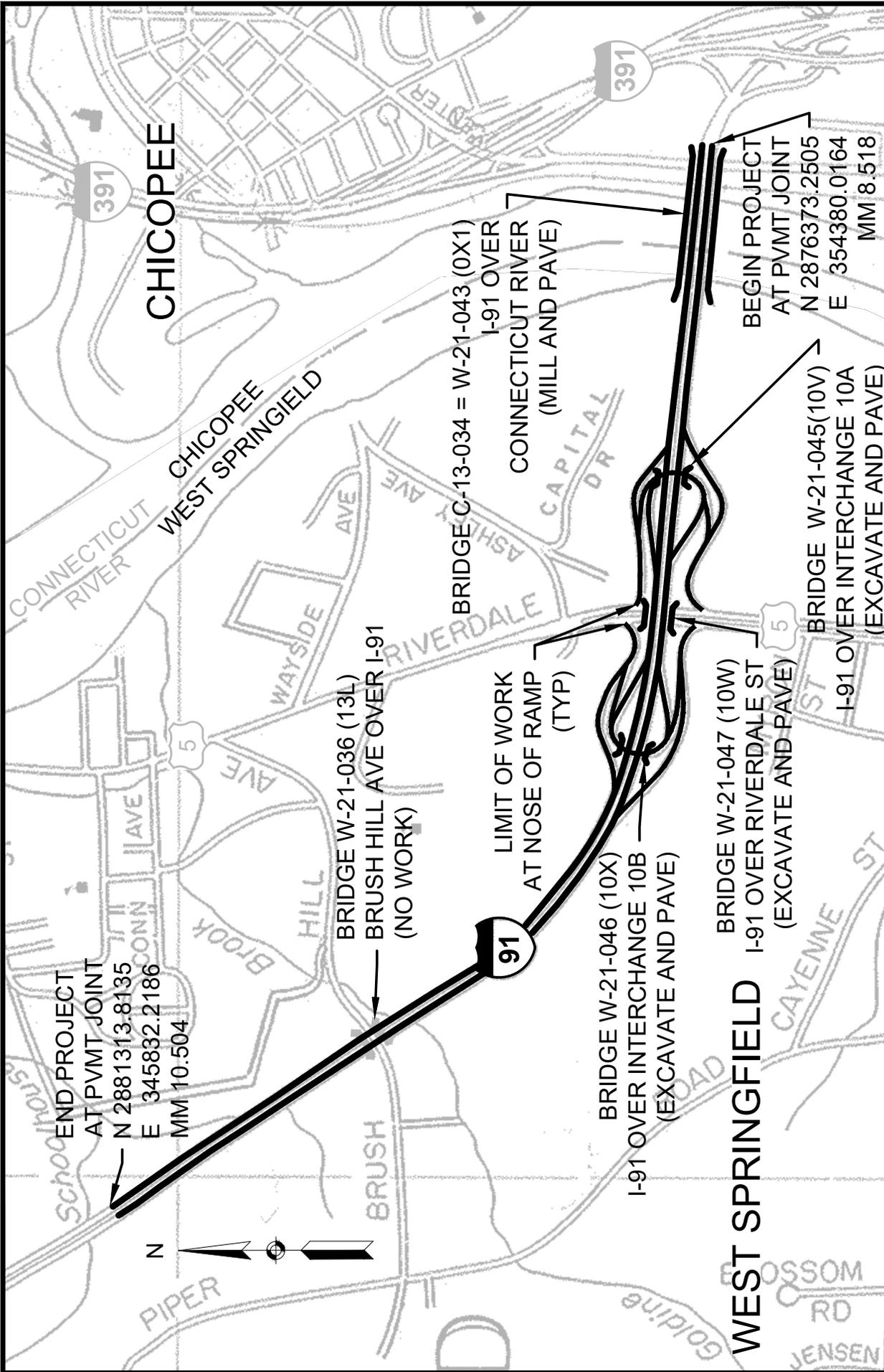

LOCUS

MM 8.518 TO 10.504
PROJECT LENGTH = 10,486.08 FEET = 1.986 MILES

DATE:	10/29/24
SCALE:	NTS
PROJECT NO.:	612097
SHEET	1 OF 1

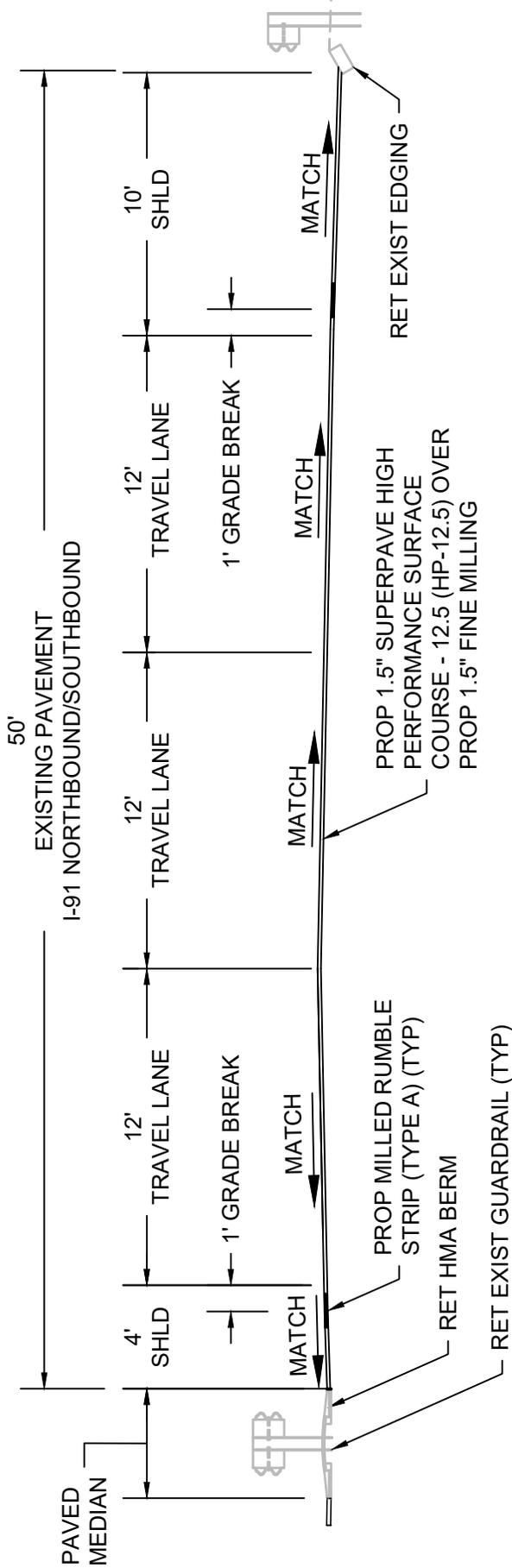

DATE:	7/15/2024
SCALE:	NTS
PROJECT NO.:	612097
SHEET 1 OF 5	

I-91 WEST SPRINGFIELD/CHICOPEE
 TYPICAL SECTION - NORMAL CROWN (MM 8.77 TO 9.40)

MassDOT
 Highway Division
HIGHWAY DESIGN

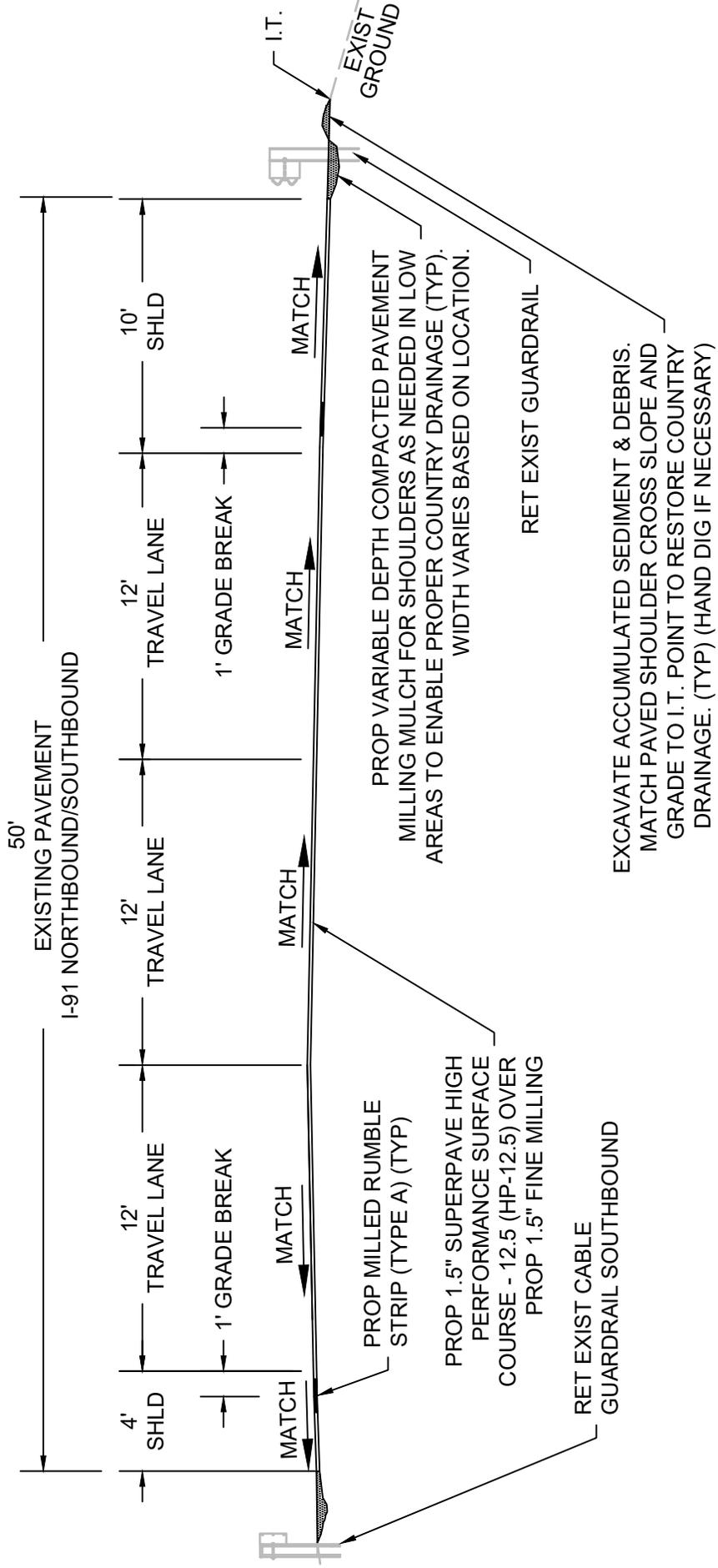

DATE:	7/15/2024
SCALE:	NTS
PROJECT NO.:	612097
SHEET	2 OF 5

I-91 WEST SPRINGFIELD/CHICOPEE

TYPICAL SECTION - NORMAL CROWN (MM 9.75 TO 10.50)



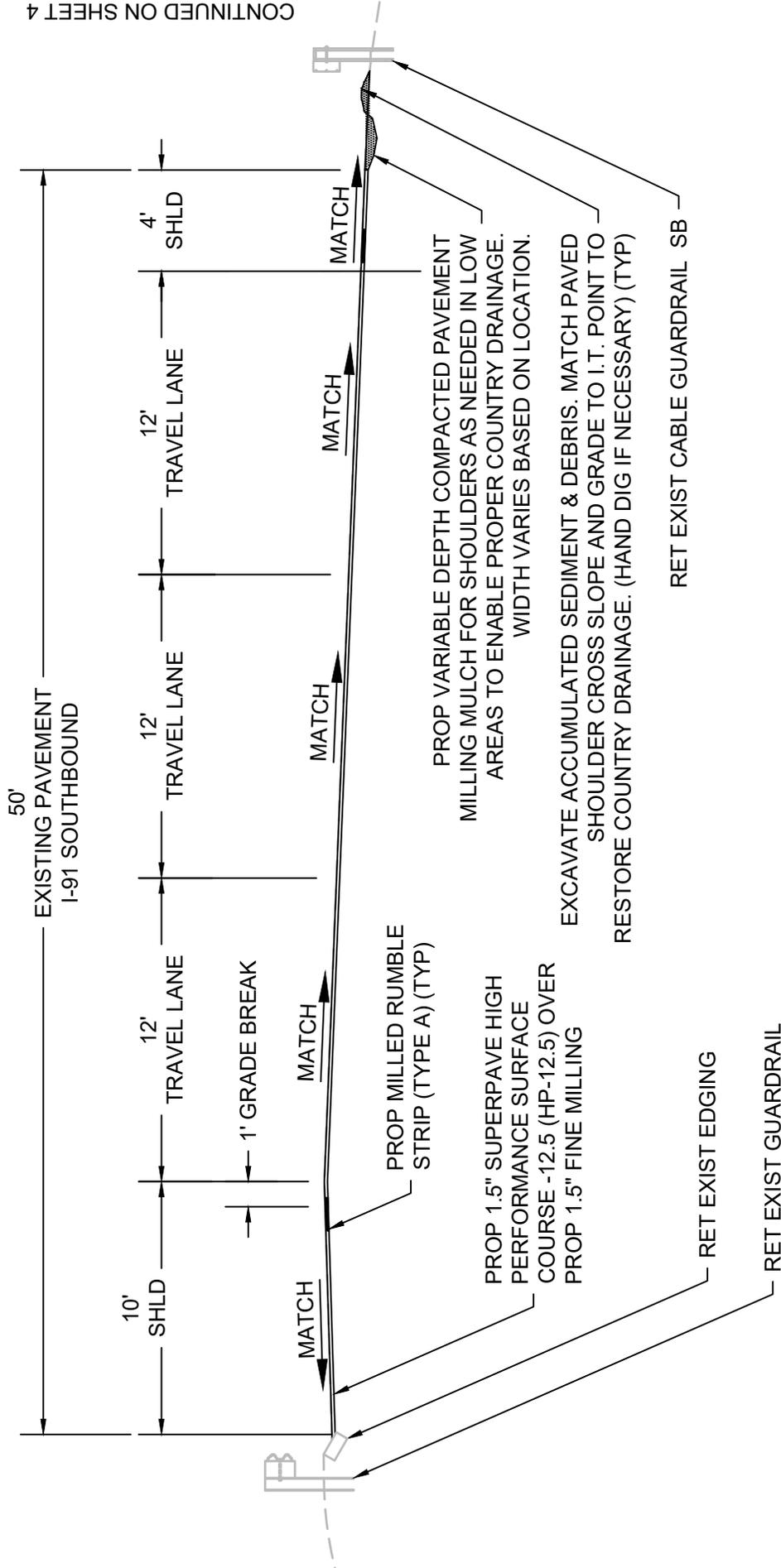

CONTINUED ON SHEET 4

DATE:	7/15/2024
SCALE:	NTS
PROJECT NO.:	612097
SHEET 3 OF 5	

I-91 WEST SPRINGFIELD/CHICOPEE
 TYPICAL SECTION - SUPERELEVATED (MM 9.40 TO 9.75)



CONTINUED ON SHEET 3

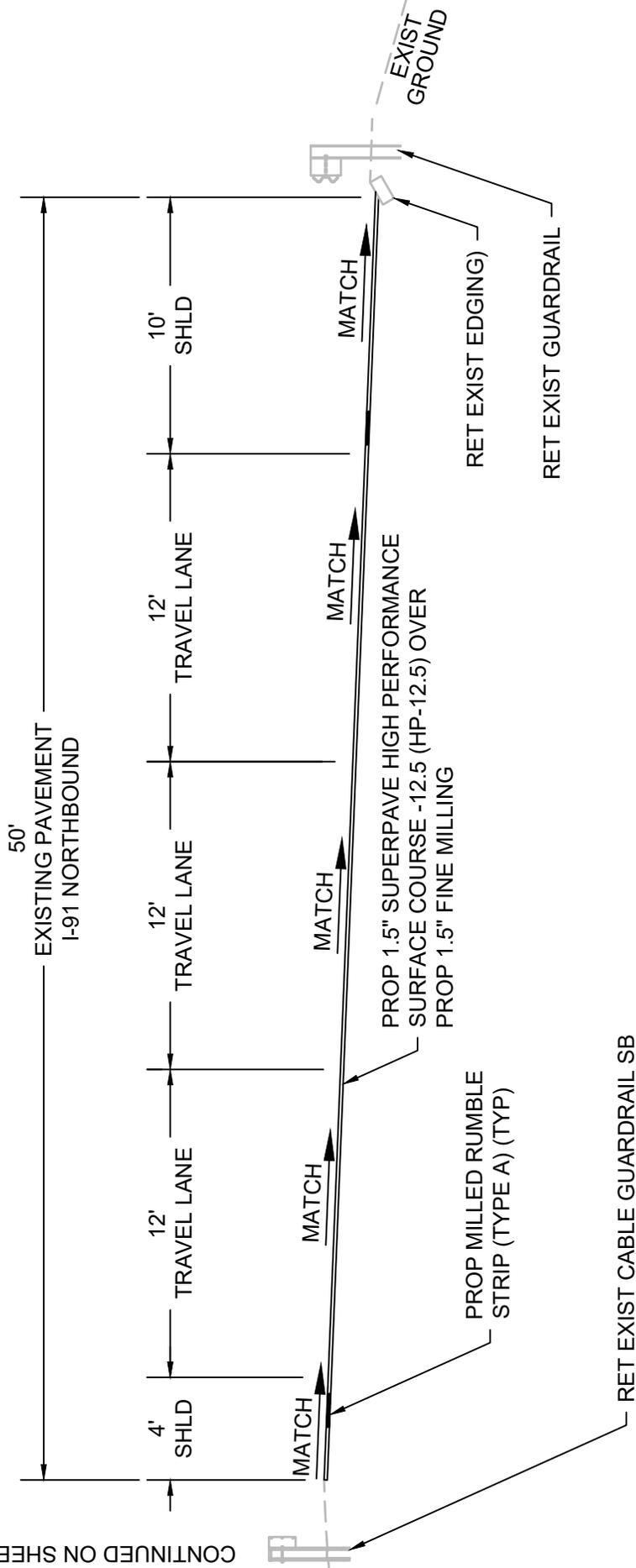

I-91 WEST SPRINGFIELD/CHICOPEE
TYPICAL SECTION - SUPERELEVATED (MM 9.40 TO 9.75)

DATE:	7/15/2024
SCALE:	NTS
PROJECT NO.:	612097
SHEET	4 OF 5

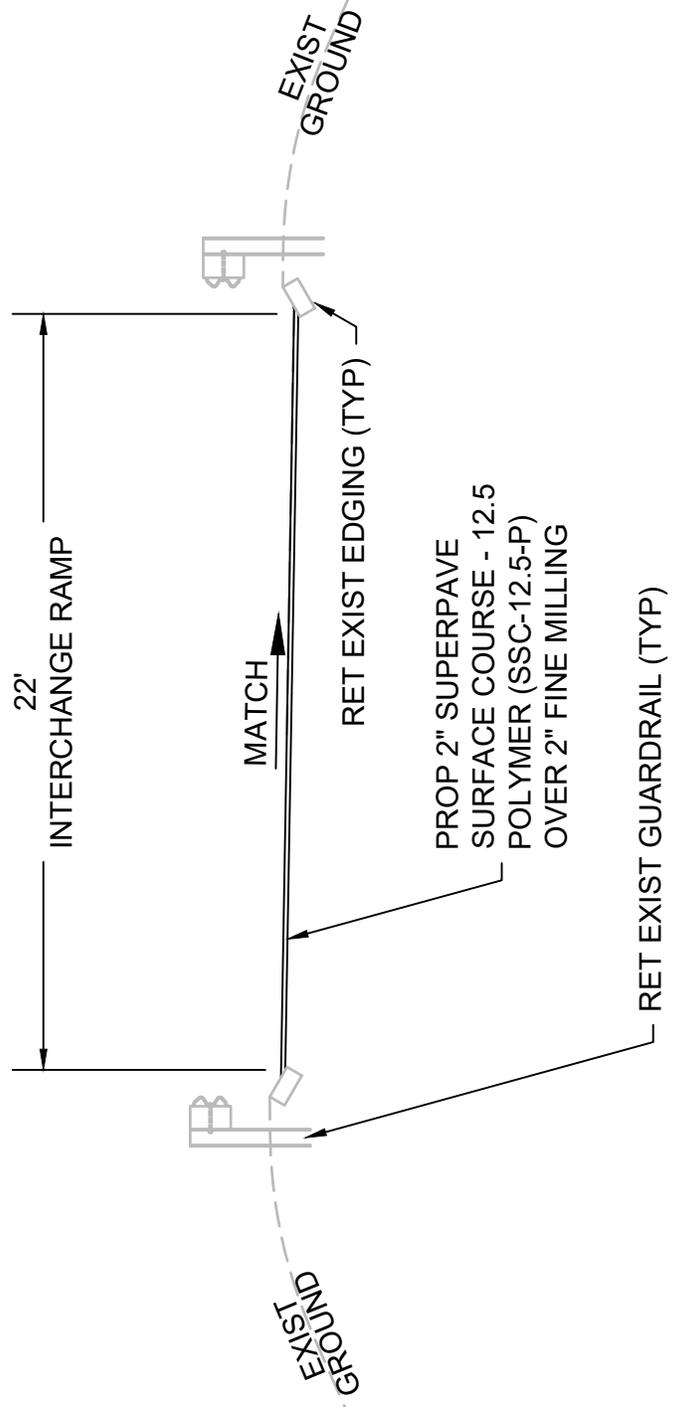

DATE:	7/15/2024
SCALE:	NTS
PROJECT NO.:	612097
SHEET	5 OF 5

I-91 WEST SPRINGFIELD/CHICOPEE
 TYPICAL SECTION (INTERCHANGE 10A AND 10B)



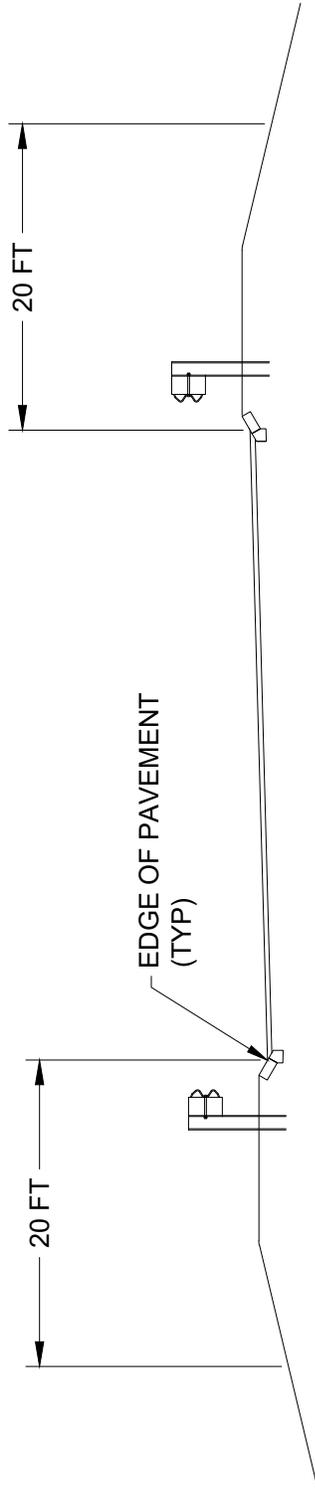

LIMITS OF ITEM 101.1.: CLEARING
(ON MAINLINE/RAMP AREAS WITH GUARDRAIL)
 NOT TO SCALE

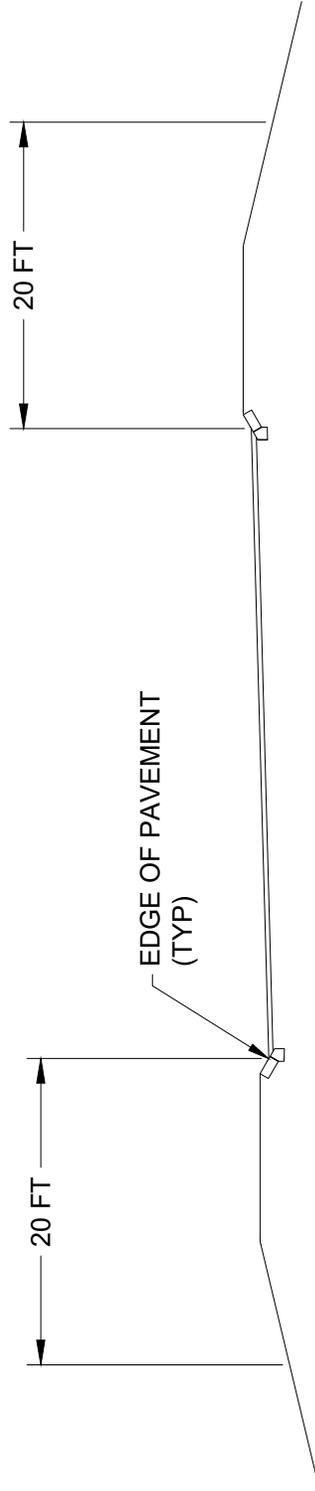

LIMITS OF ITEM 101.1.: CLEARING
(ON MAINLINE/RAMP AREAS WITHOUT GUARDRAIL)
 NOT TO SCALE



TREE CLEARING

DATE: 12/28/23
SCALE: NTS
PROJECT NO.: 612097
SHEET 1 OF 54

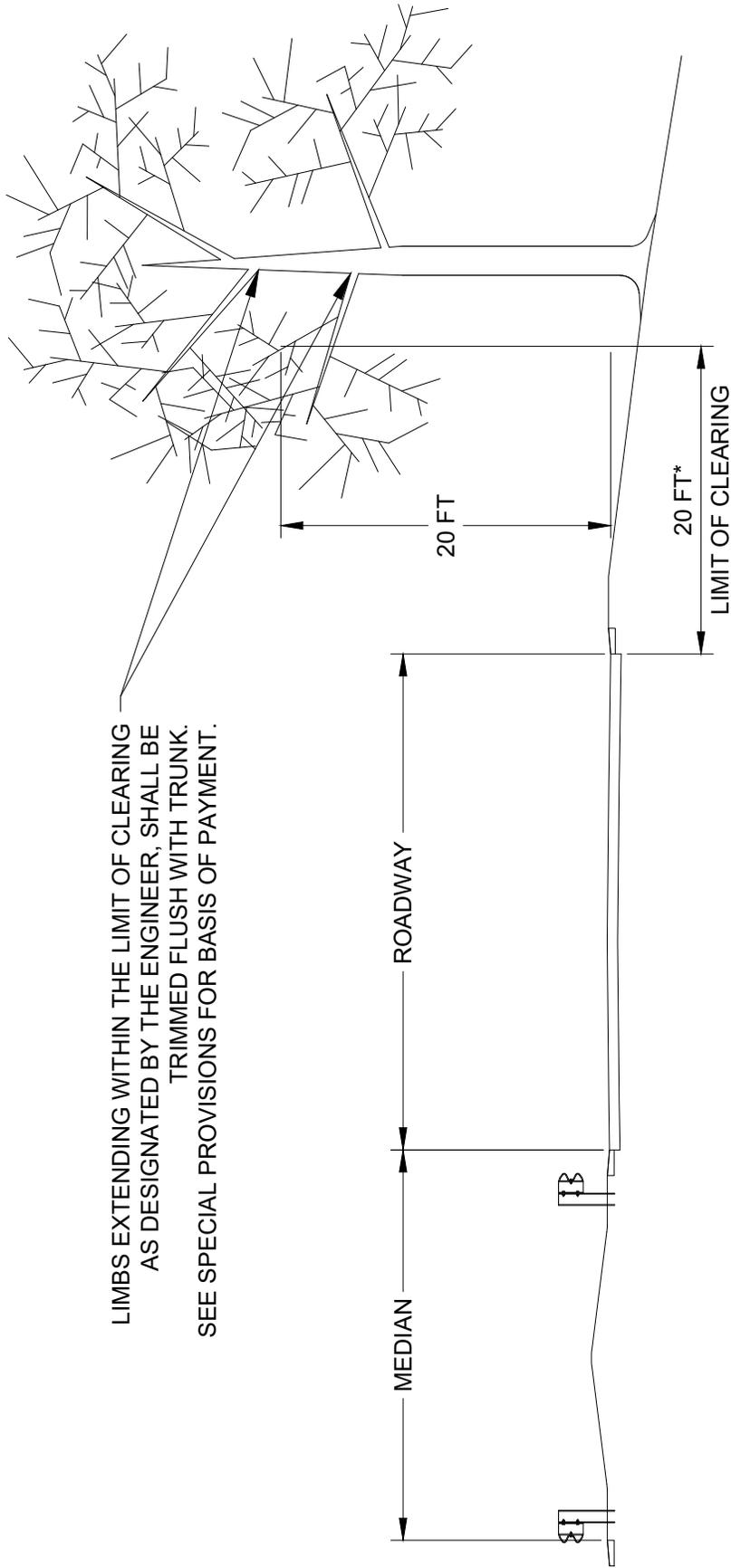

TYPICAL SECTION - ITEM 102.1
TREE TRIMMING
 NOT TO SCALE

*NOTE: TREE TRIMMING SHALL BE LIMITED TO 6 FEET BEYOND THE BACK OF GUARDRAIL IN VEGETATED WETLANDS BUFFER ZONES, AS OUTLINED IN THE DETAIL SHEETS.



DATE: 12/28/23

SCALE: NTS

PROJECT NO.: 612097

SHEET 2 OF 54

TREE TRIMMING

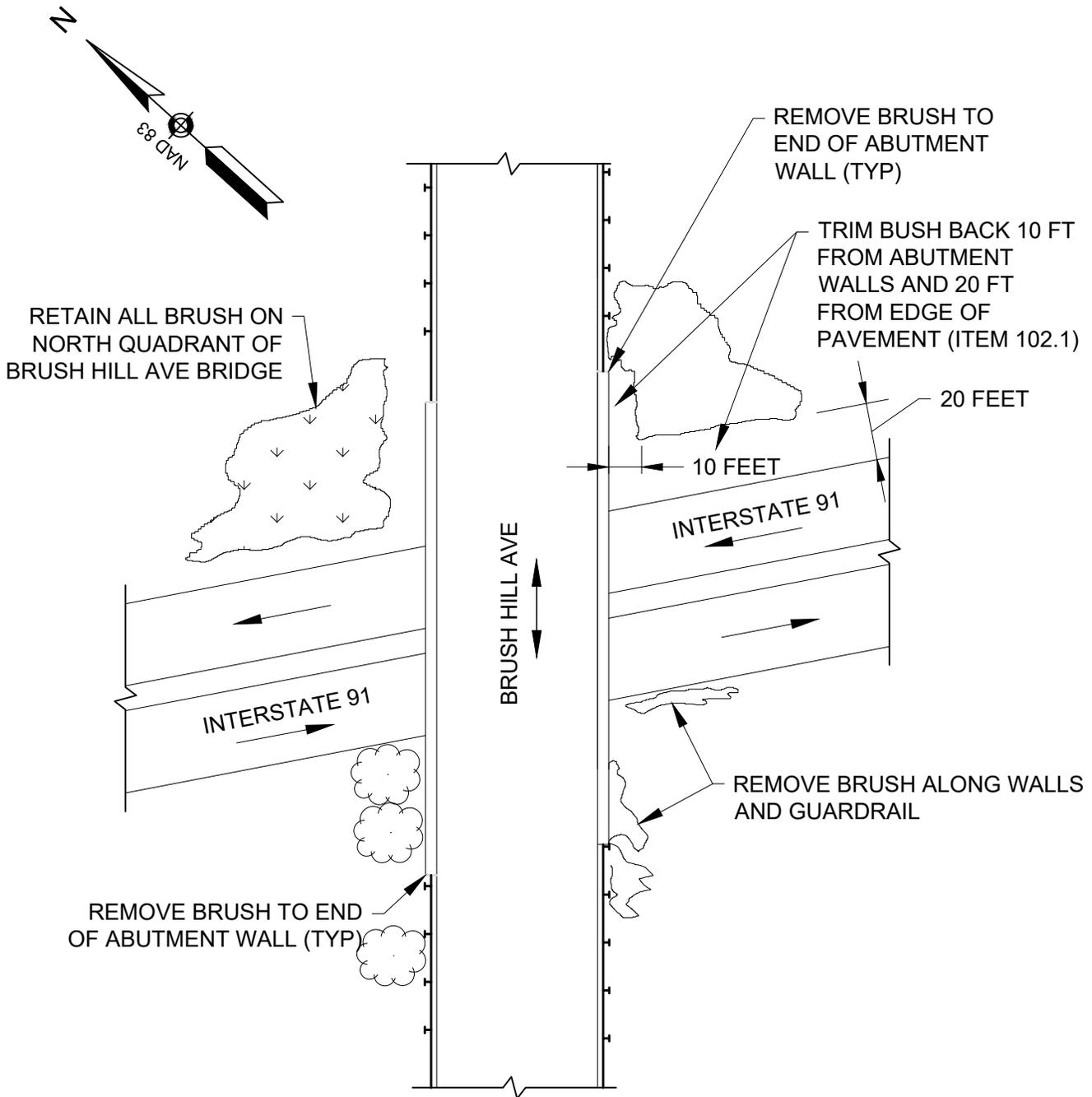

PLAN VIEW - ITEM 101.1:
CLEARING
(AT BRIDGES)
 NOT TO SCALE

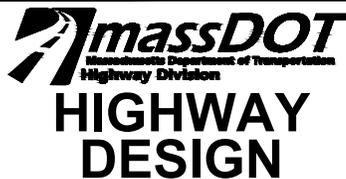

TREE CLEARING

DATE: 12/28/23

SCALE: NTS

PROJECT NO.: 612097

SHEET 3 OF 54

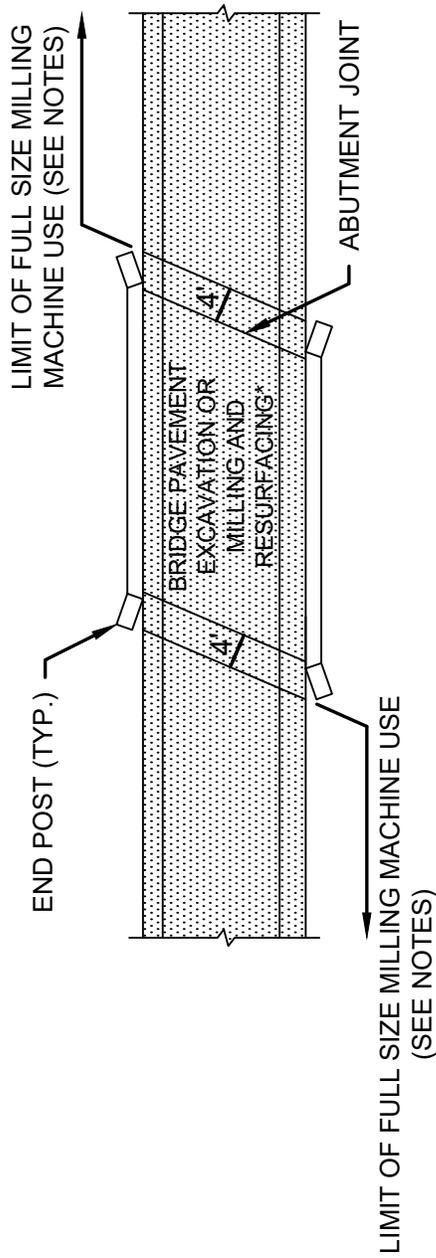

- *PAVEMENT REMOVAL METHODS:
- W-21-045 - 2.5" PAVEMENT EXC.
 - W-21-046 - 2.5" PAVEMENT EXC.
 - W-21-047 - 2.5" PAVEMENT EXC.
 - C-13-034=W-21-043 - 2" MILLING

PLAN VIEW
NTS

GENERAL NOTE:

1. MILLING WITH FULL SIZE MILLING MACHINE SHALL BE TERMINATED A MINIMUM OF 4 FEET FROM THE FIRST BRIDGE JOINT APPROACHING THE BRIDGE DECK.
2. THE FINAL 4 FEET UP TO THE BRIDGE JOINT SHALL BE COMPLETED WITH A SELF-PROPELLED WALK BEHIND MACHINE AS REQUIRED.
3. BRIDGE PAVEMENT EXCAVATION SHALL BE PERFORMED ON THE DECK OF BRIDGES W-21-045, W-21-046, AND W-21-047. BRIDGE PAVEMENT MILLING SHALL BE PERFORMED ON THE DECK OF BRIDGE C-13-034 = W-21-043.
4. NO PORTION OF THE CONCRETE BRIDGE DECK SHALL BE EXPOSED TO LIVE TRAFFIC FOR MORE THAN 14 CALENDAR DAYS PRIOR TO FINAL PAVING. NO PORTION OF THE MILLED BRIDGE DECK SHALL BE EXPOSED TO LIVE TRAFFIC FOR MORE THAN 7 CALENDAR DAYS PRIOR TO FINAL PAVING.

LIMIT OF MILLING AT BRIDGE DECKS
NOT TO SCALE



LIMIT OF MILLING AT BRIDGE DECKS

DATE: 12/28/23

SCALE: NTS

PROJECT NO.: 612097

SHEET 4 OF 54

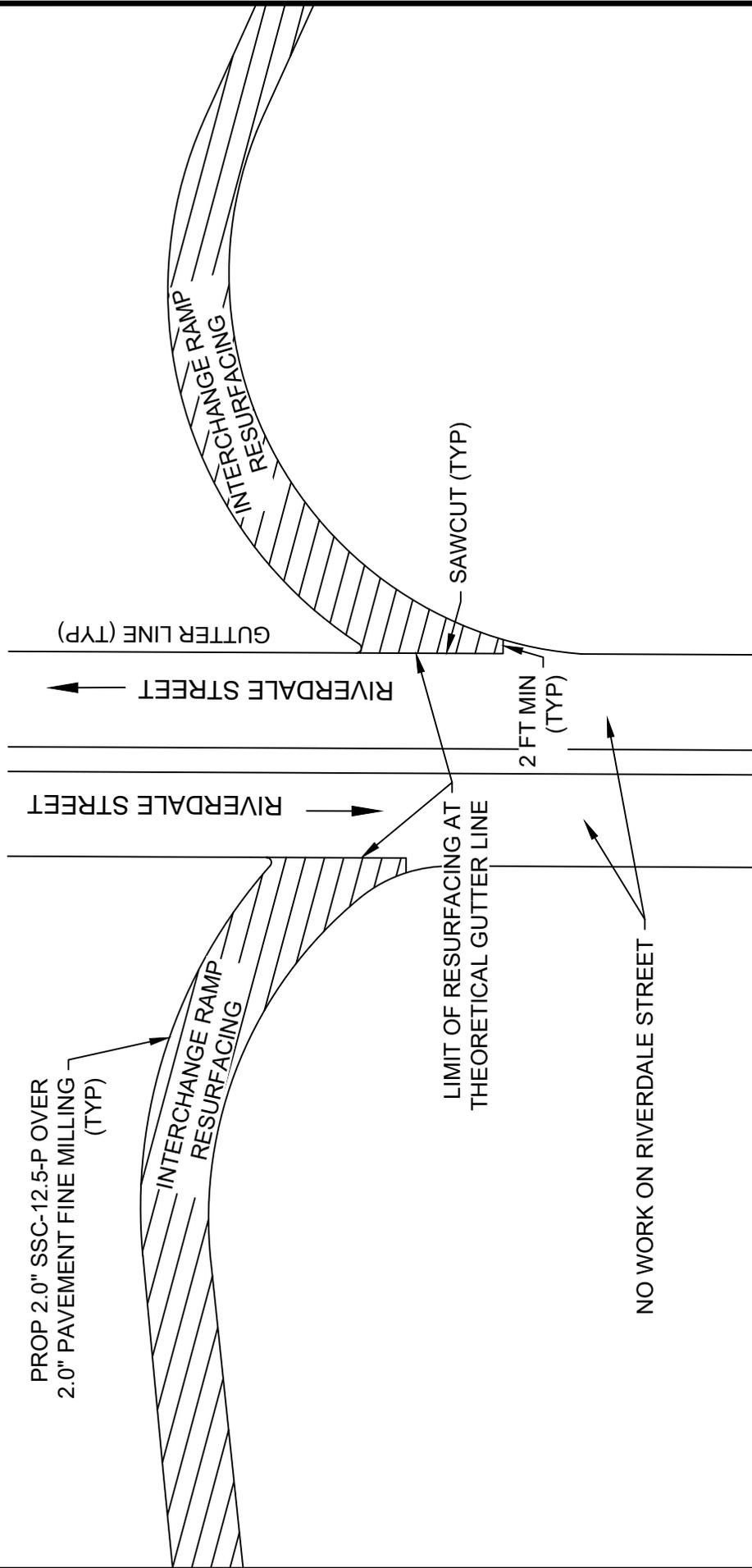

NOTE: THIS DETAIL IS APPLICABLE TO ALL FOUR
RAMPS CONNECTING I-91 AND RIVERDALE STREET

DATE: 12/28/23
SCALE: NTS
PROJECT NO.: 612097
SHEET 5 OF 54

INTERCHANGE RAMP PAVING LIMITS



LEGEND

- # - SLOTTED ONE-WAY WHITE PAVEMENT MARKERS
- Δ - SLOTTED TWO-WAY WHITE /RED PAVEMENT MARKER
- Z - SLOTTED TWO-WAY YELLOW/RED PAVEMENT MARKER

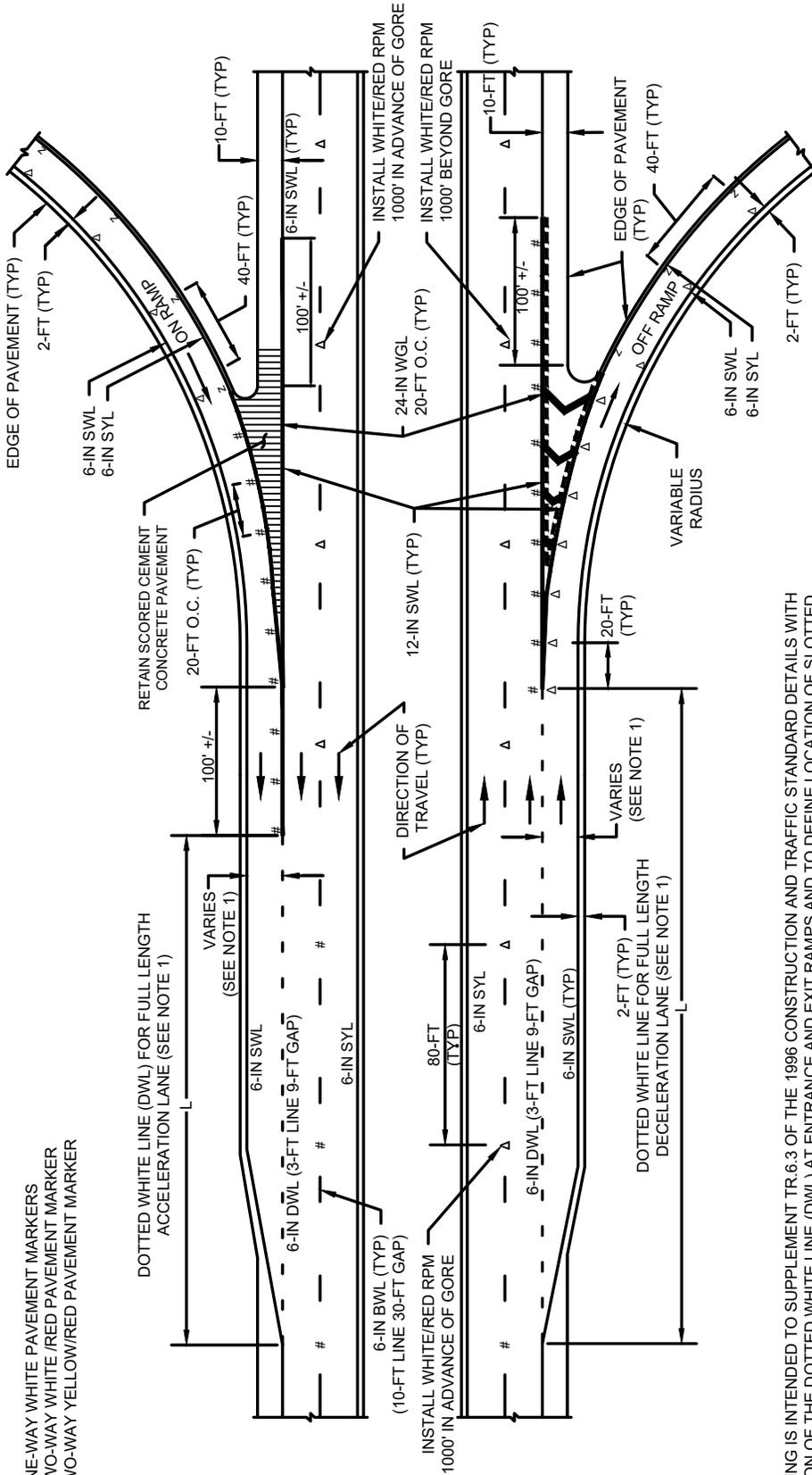

NOTES:

THIS DRAWING IS INTENDED TO SUPPLEMENT TR 6.3 OF THE 1996 CONSTRUCTION AND TRAFFIC STANDARD DETAILS WITH THE ADDITION OF THE DOTTED WHITE LINE (DWL) AT ENTRANCE AND EXIT RAMP AND TO DEFINE LOCATION OF SLOTTED PAVEMENT MARKERS.

1. IF FULL WIDTH ACCELERATION LANE OR DECELERATION LANE IS LESS THAN 10- FEET WIDE, DO NOT INSTALL 6-IN DOTTED WHITE LINES (DWL).
2. ALL PAVEMENT MARKINGS SHALL CONFORM TO THE CURRENT M.U.T.C.D.
3. SEE DRAWING TR.6.1 OF THE 1996 CONSTRUCTION AND TRAFFIC STANDARD DETAILS FOR PAVEMENT MARKING TABLES.
4. RED REFLECTORS SHALL FACE AWAY FROM ONCOMING TRAFFIC.
5. SEE DRAWING TR.6.2 OF THE 1996 CONSTRUCTION AND TRAFFIC STANDARD DETAILS FOR ADDITIONAL SLOTTED PAVEMENT MARKER INSTALLATION GUIDANCE.

TYPICAL PAVEMENT MARKINGS AT GORE AREA

NOT TO SCALE



PAVEMENT MARKINGS & SLOTTED PAVEMENT MARKERS

DATE: 12/28/23

SCALE: NTS

PROJECT NO.: 612097

SHEET 6 OF 54

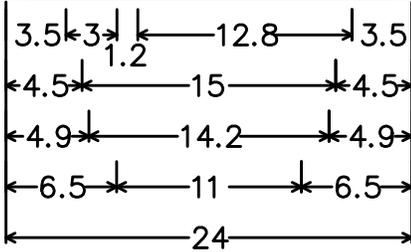
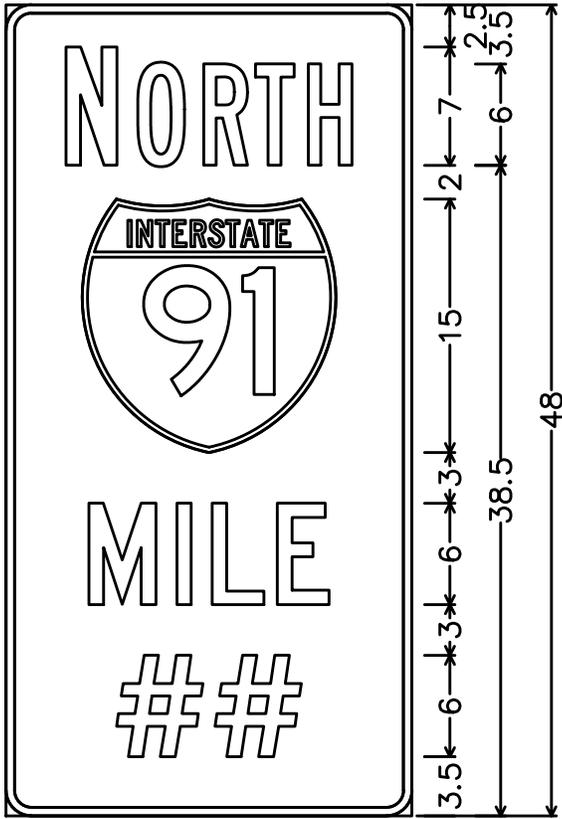

MA-D10-4a;
 1.5" Radius, 0.5" Border, White on Green;
 "NORTH", B 2K;
 "MILE", C 2K specified length;
 "##", D 2K;

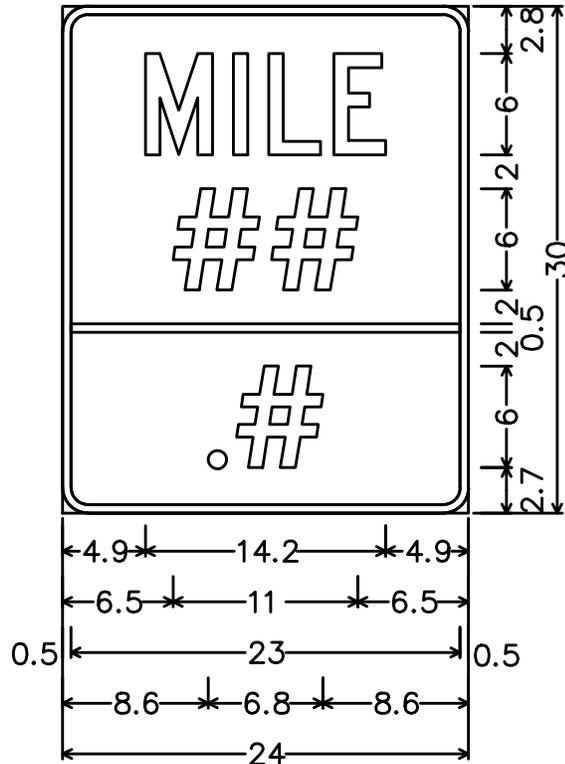

MA-D10-2b;
 1.5" Radius, 0.5" Border, White on Green;
 "MILE", C 2K specified length;
 "##", D 2K; ".#", D 2K;

NOTE: FROM MASSDOT STANDARD SIGNS BOOK



DEMOUNTABLE REFLECTORIZED
 REFERENCE LOCATION SIGNS

DATE: 12/28/23
 SCALE: NTS
 PROJECT NO.: 612097
 SHEET 7 OF 54

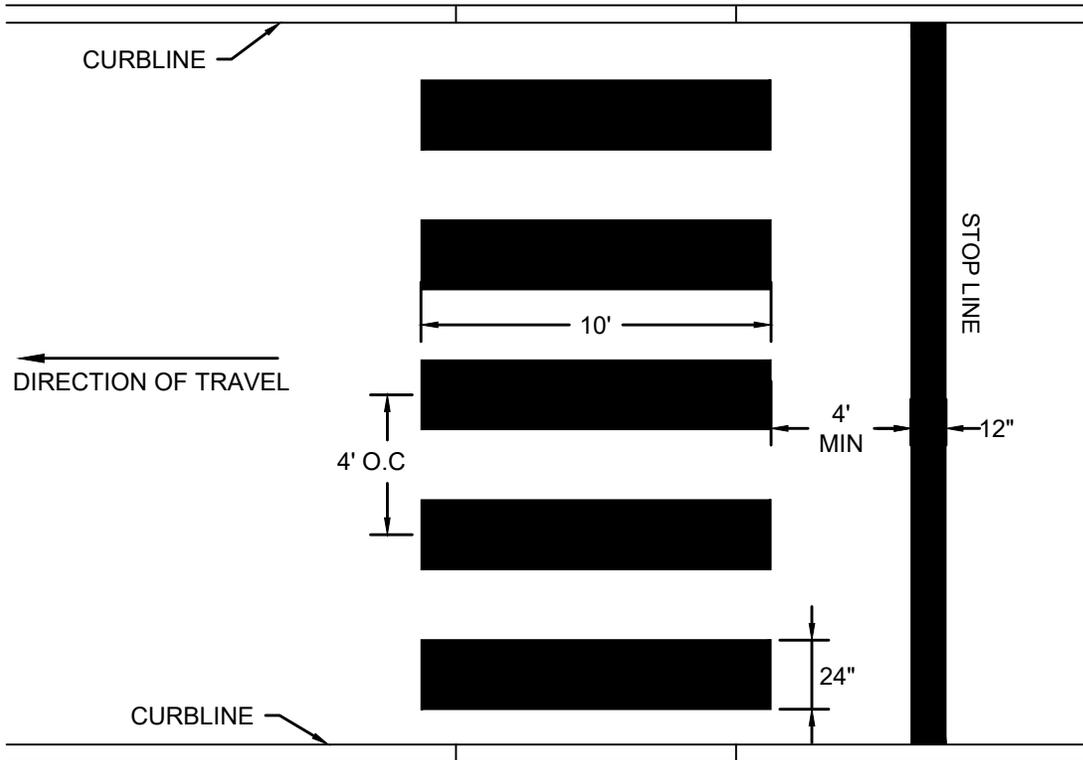

NOTES:

- LAYOUT OF CROSSWALKS SHALL BE ORIENTATED IN THE DIRECTION OF TRAVEL AND LOCATED OUTSIDE OF THE WHEEL PATH OF VEHICLES.

CONTINENTAL STYLE CROSSWALK

NOT TO SCALE

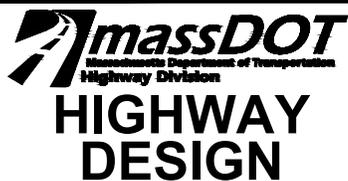

CROSSWALK DETAIL

DATE: 10/29/24

SCALE: NTS

PROJECT NO.: 612097

SHEET 8 OF 54

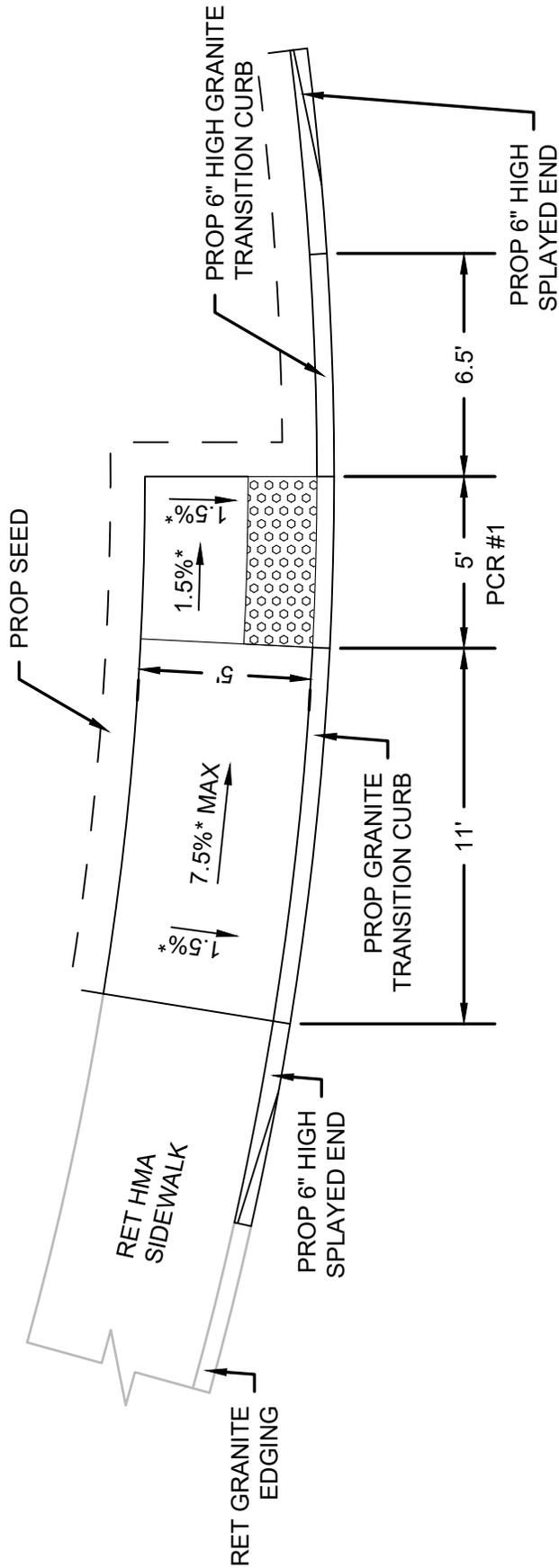

* CONSTRUCTION TOLERANCE ±0.5%

PCR NO.	RAMP REFERENCE POINT LOCATION (STATE I.D. #)	SIDEWALK WIDTH	ROADWAY GUTTER SLOPE	RAMP ENTRANCE WIDTH	TRANSITION LENGTH	
					HIGH SIDE	LOW SIDE
1	SOUTH SIDE OF SB INTERCHANGE 10B OFF RAMP (PED-13928)	5'±	2.2%	5'±	11'	-

PEDESTRIAN CURB RAMP ON SOUTH SIDE OF SB INTERCHANGE 10B OFF RAMP

NOT TO SCALE

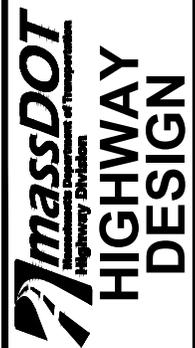

PEDESTRIAN CURB RAMP ON SOUTH SIDE OF SB INTERCHANGE 10B OFF RAMP (PED-13928)

DATE: 11/15/24

SCALE: NTS

PROJECT NO.: 612097

SHEET: 9 OF 54

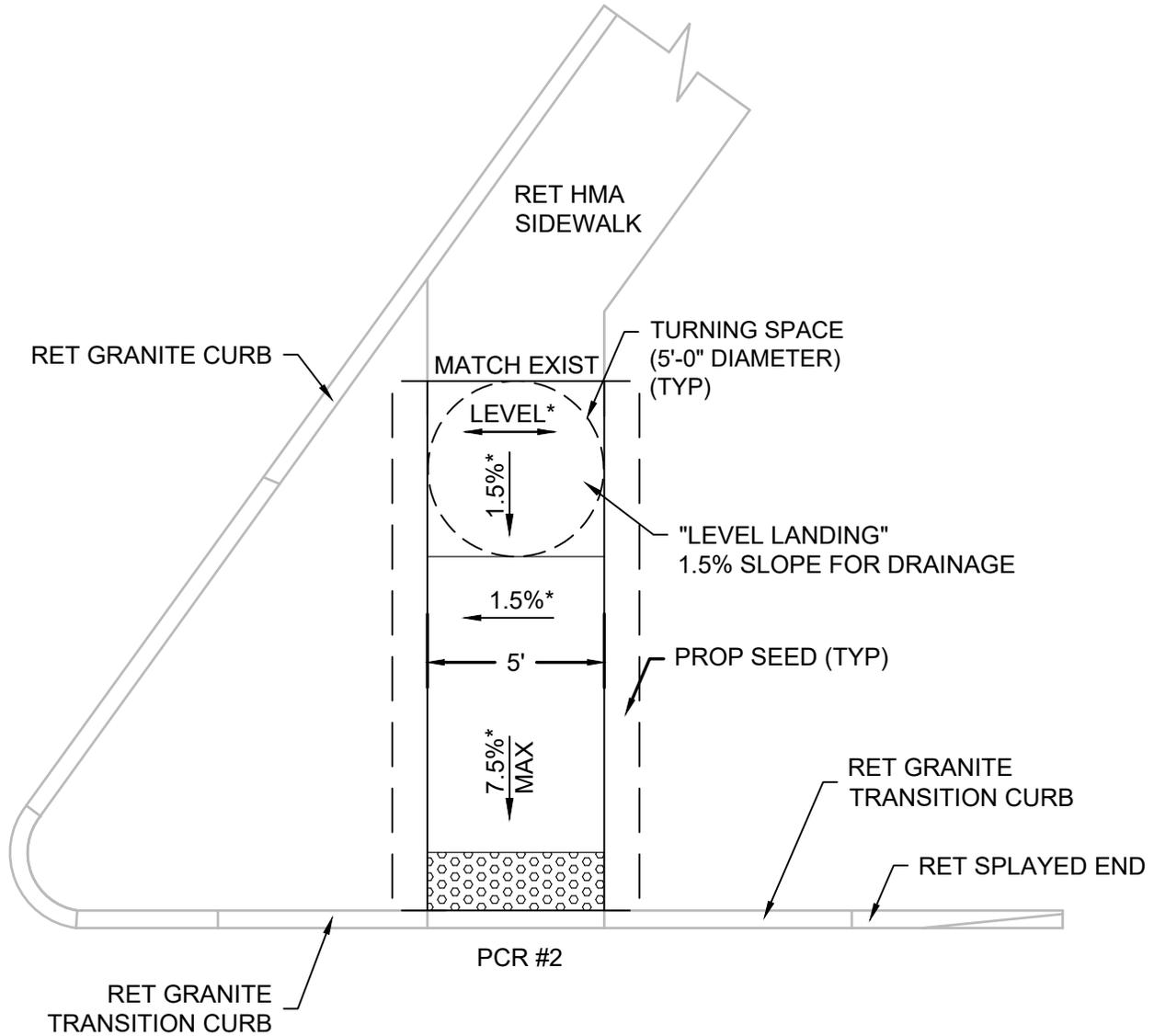

*CONSTRUCTION TOLERANCE ±0.5%

PCR NO.	RAMP REFERENCE POINT	SIDEWALK WIDTH	ROADWAY GUTTER SLOPE	RAMP ENTRANCE WIDTH	TRANSITION LENGTH	
	LOCATION (STATE I.D. #)				HIGH SIDE	LOW SIDE
2	NORTH SIDE OF SB INTERCHANGE 10A ON RAMP (PED-5549)	5'±	0.3%	5'±	10.83'	-

PEDESTRIAN CURB RAMP ON NORTH SIDE OF SB INTERCHANGE 10A ON RAMP
NOT TO SCALE



PEDESTRIAN CURB RAMP NORTH SIDE OF SB INTERCHANGE 10A ON RAMP (PED-5549)

DATE: 11/15/24
 SCALE: NTS
 PROJECT NO.: 612097
 SHEET 10 OF 54

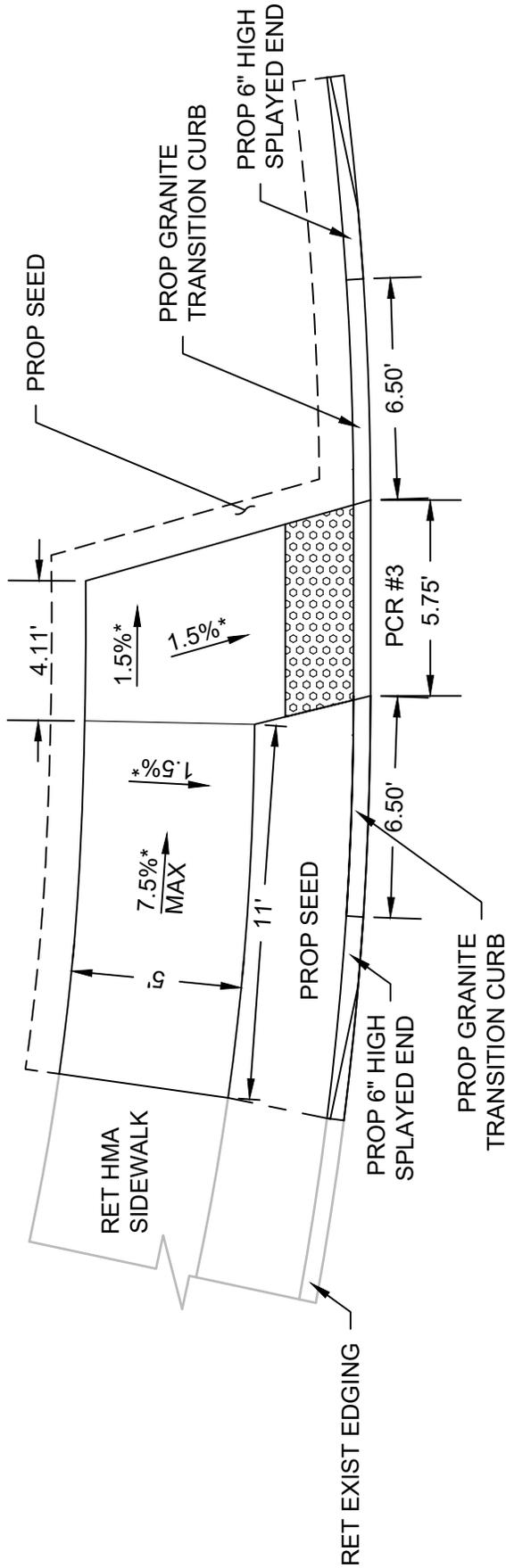

* CONSTRUCTION TOLERANCE ±0.5%

PCR NO.	RAMP REFERENCE POINT LOCATION (STATE I.D. #)	SIDEWALK WIDTH	ROADWAY GUTTER SLOPE	RAMP ENTRANCE WIDTH	TRANSITION LENGTH	
					HIGH SIDE	LOW SIDE
3	NORTH SIDE OF NB INTERCHANGE 10A OFF RAMP (PED-12447)	5±	2.1%	5.75±	11'	-

PEDESTRIAN CURB RAMP ON NORTH SIDE OF NB INTERCHANGE 10A OFF RAMP

NOT TO SCALE



PEDESTRIAN CURB RAMP ON NORTH SIDE OF NB
INTERCHANGE 10A OFF RAMP (PED-12447)

DATE: 11/15/24

SCALE: NTS

PROJECT NO.: 612097

SHEET: 11 OF 54

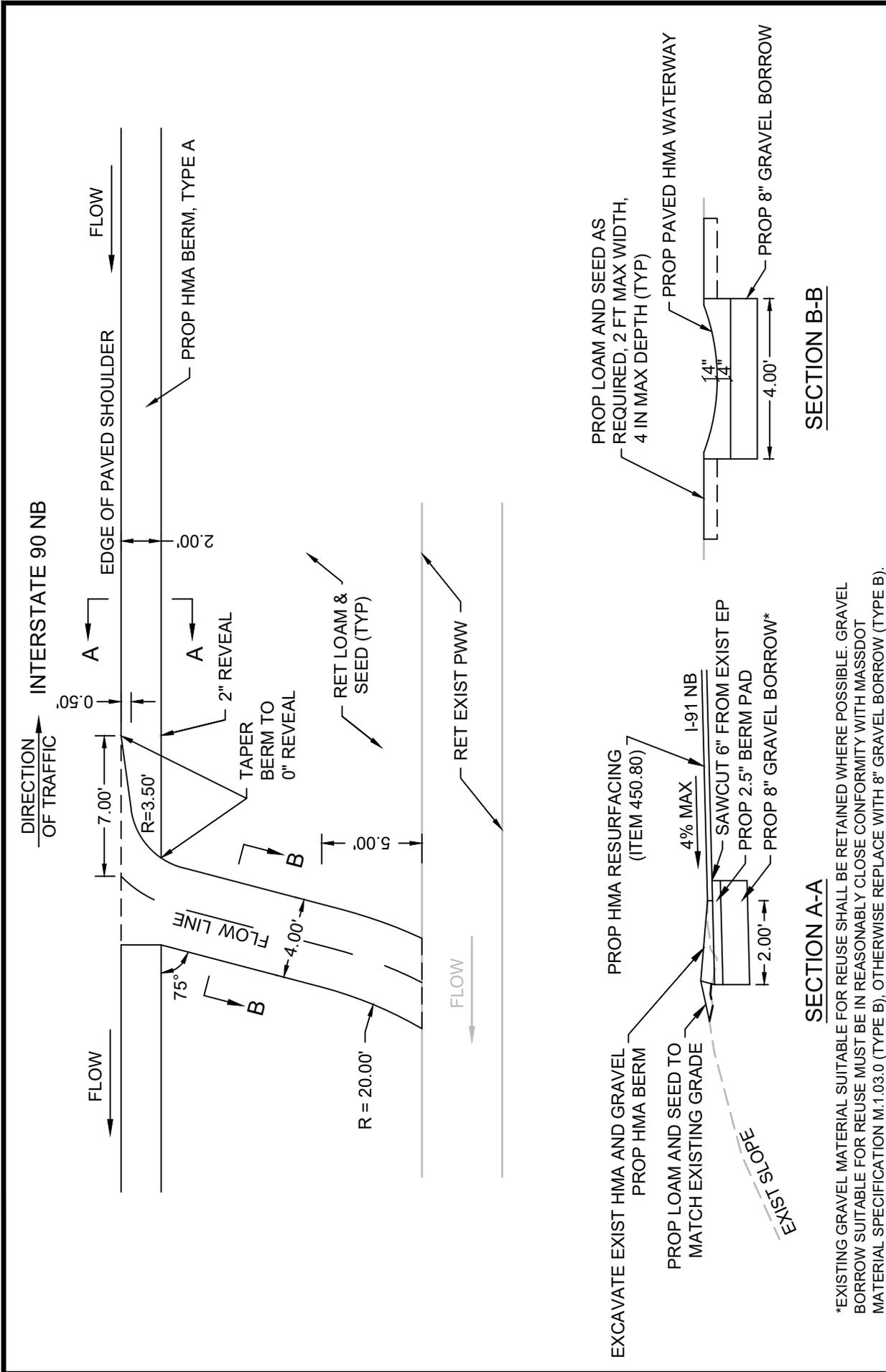

SECTION A-A

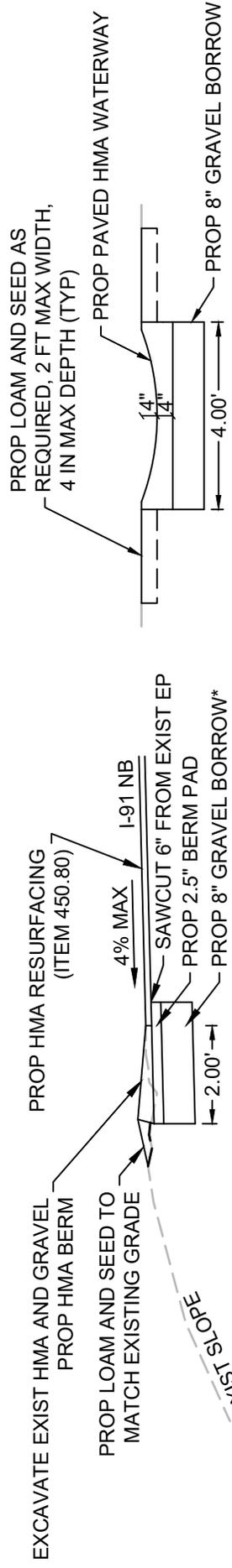

SECTION B-B

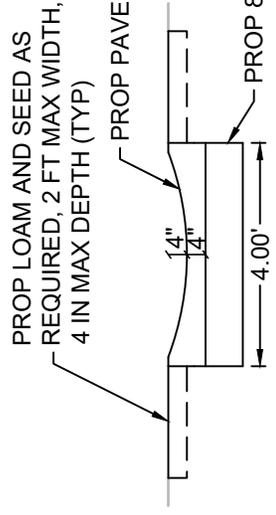

*EXISTING GRAVEL MATERIAL SUITABLE FOR REUSE SHALL BE RETAINED WHERE POSSIBLE. GRAVEL BORROW SUITABLE FOR REUSE MUST BE IN REASONABLY CLOSE CONFORMITY WITH MASSDOT MATERIAL SPECIFICATION M.1.03.0 (TYPE B). OTHERWISE REPLACE WITH 8" GRAVEL BORROW (TYPE B).

 <p>MASSDOT Highway Division HIGHWAY DESIGN</p>	<p>PROP PAVED WATERWAY</p> <p>I-91 NB SHOULDER (MM 9.68 TO 9.87)</p>		<p>DATE: 12/28/23</p>
	<p>SCALE: NTS</p>		<p>PROJECT NO.: 612097</p>
			<p>SHEET 12 OF 54</p>

TRAFFIC DATA COLLECTION STATIONS – ITEM 819.907

**TYPICAL ROAD SENSOR LAYOUT FOR CLASSIFICATION TRAFFIC COUNTING STATION
3 LANES – 1 DIRECTION**

8 FEET BETWEEN PIEZOS AND 10 FEET BETWEEN LOOPS IN EACH LANE

11 FOOT Class 2 PIEZOS

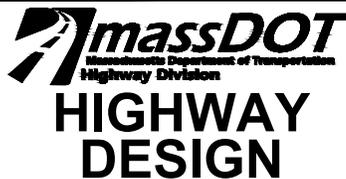
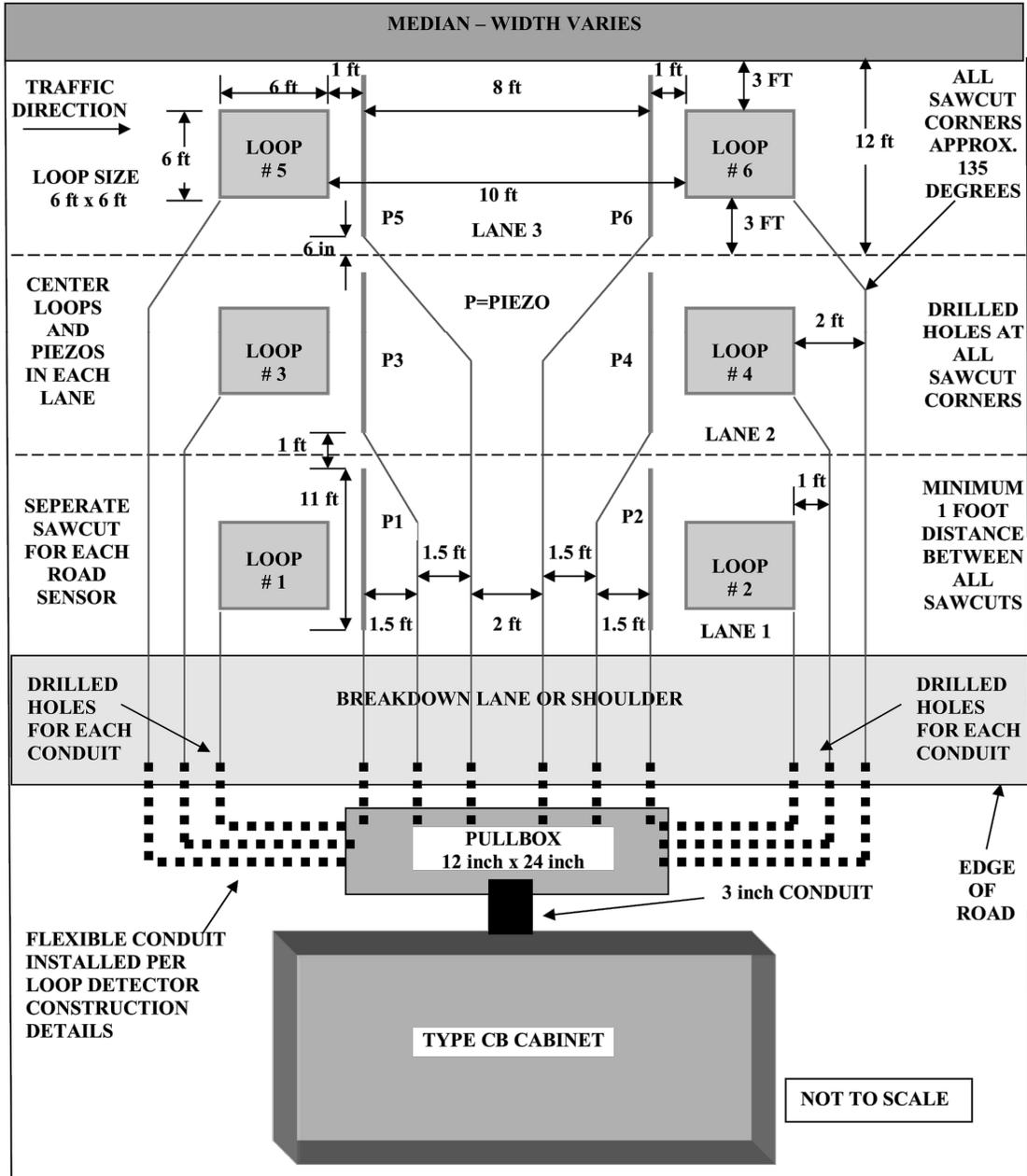

**TRAFFIC DATA COLLECTION
STATION - ROAD SENSOR LAYOUT**

DATE: 7/31/24

SCALE: NTS

PROJECT NO.: 612097

SHEET 13 OF 54

TYPICAL LOOP WIRE INSTALLATION

(not to scale)

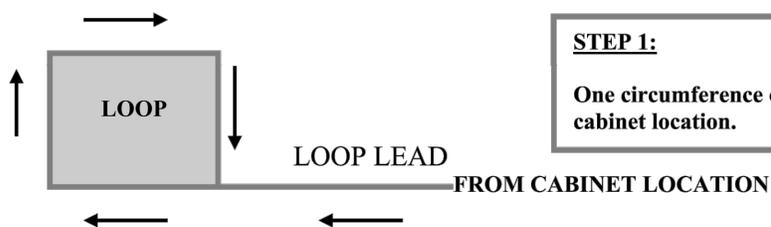

STEP 1:
One circumference of loop wire beginning at the cabinet location.

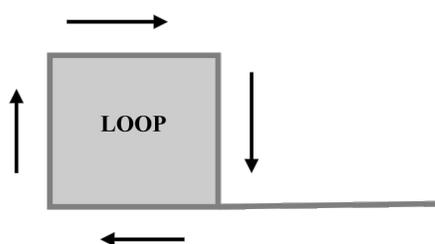

Step 2:
Second circumference of loop wire over first circumference.

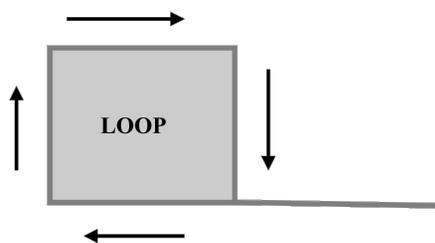

Step 3:
Third circumference of loop wire over second circumference.

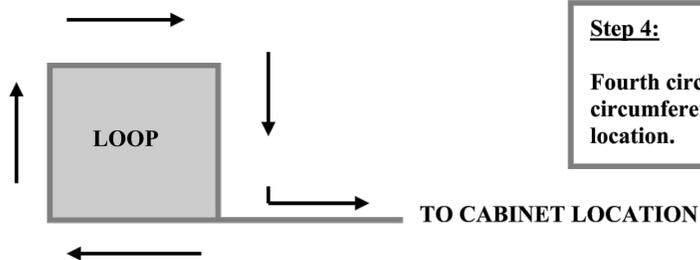

Step 4:
Fourth circumference of loop wire over third circumference and return to the cabinet location.

Note: This loop wire installation procedure is applicable to each loop installation



TRAFFIC DATA COLLECTION
STATION - WIRE LOOP
INSTALLATION

DATE: 7/31/24
SCALE: NTS
PROJECT NO.: 612097
SHEET 14 OF 54

LOOP DETECTOR CONSTRUCTION DETAILS (not to scale)

Each intersecting sawcut or lead-in angle point shall have a 1/4 in diameter drilled hole. Loops shall be 4 turns of 12 AWG stranded wire (see "Typical Loop Wire Installation") unless otherwise specified. Loop wire shall be pushed into the loop slot with a blunt object (wooden stick). The flex conduit shall be a minimum of 6 in below ground level including at the road edge (drilled hole). Slots shall be filled with an approved sealing compound.

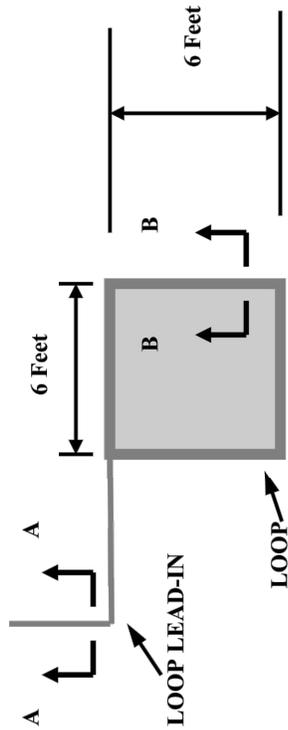

LOOP IN SLOT PLAN

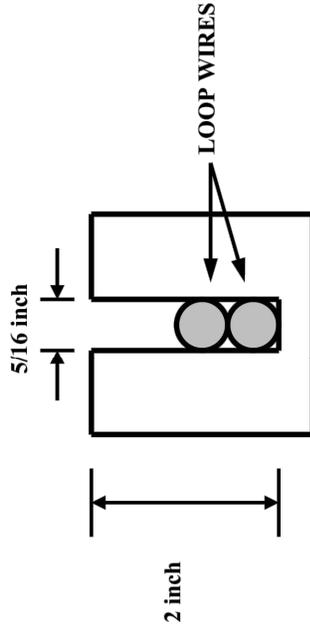

SECTION A-A (LOOP LEAD-IN)

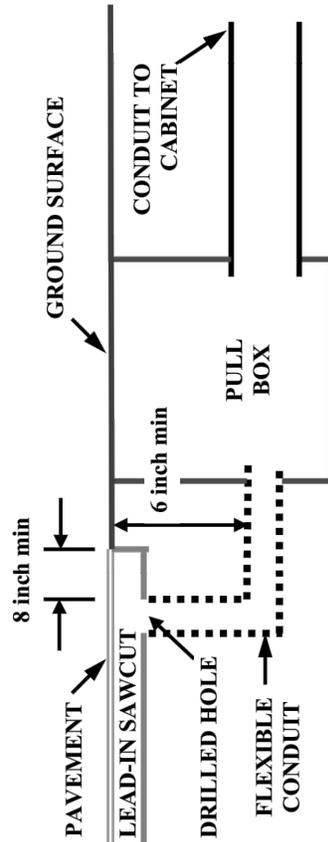

SECTION OF LOOP LEAD-IN AT PAVEMENT EDGE

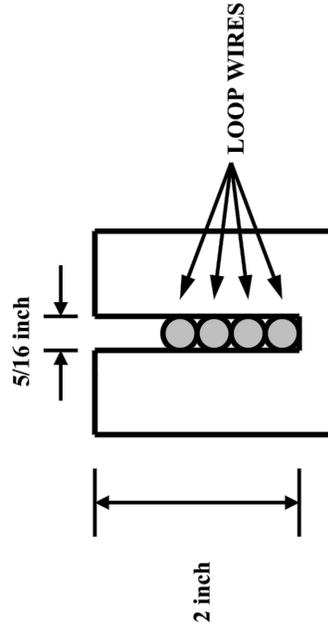

SECTION B-B (LOOP)



TRAFFIC DATA COLLECTION STATION - LOOP
DETECTOR CONSTRUCTION

DATE: 7/31/24

SCALE: NTS

PROJECT NO.: 612097

SHEET 15 OF 54

STANDARD SOLAR PANEL CONNECTION TO TRAFFIC DATA COLLECTORS

(Not to scale)

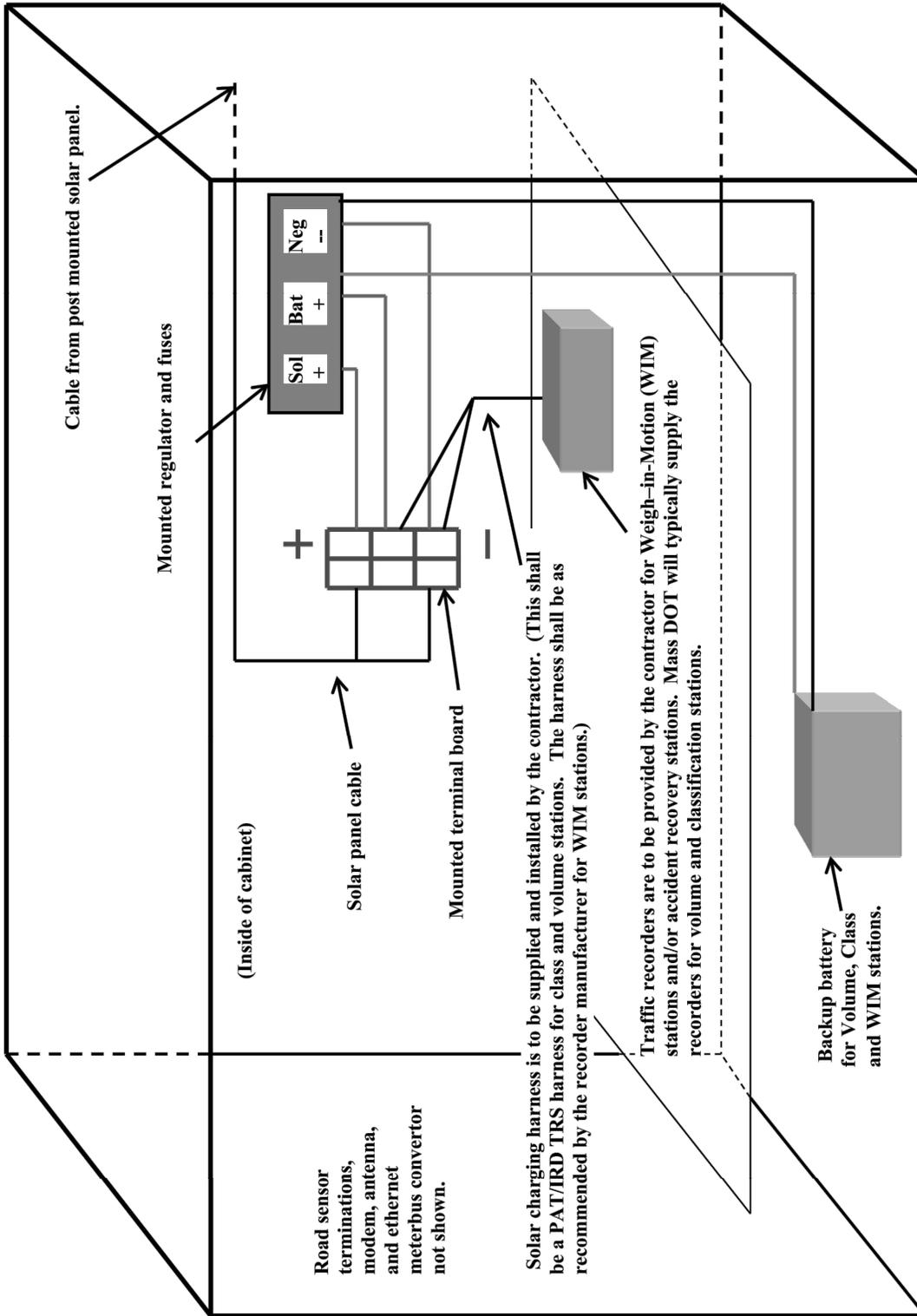

Road sensor terminations, modem, antenna, and ethernet meterbus converter not shown.

Solar charging harness is to be supplied and installed by the contractor. (This shall be a PAT/IRD TRS harness for class and volume stations. The harness shall be as recommended by the recorder manufacturer for WIM stations.)

Traffic recorders are to be provided by the contractor for Weigh-in-Motion (WIM) stations and/or accident recovery stations. Mass DOT will typically supply the recorders for volume and classification stations.

DATE: 7/31/24
SCALE: NTS
PROJECT NO.: 612097
SHEET 16 OF 54

TRAFFIC DATA COLLECTION STATION - SOLAR PANEL CONNECTION

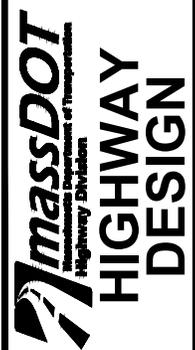

GENERAL NOTES:

1. DESIGN IS IN ACCORDANCE WITH THE 2013 STANDARD SPECIFICATIONS FOR STRUCTURAL SUPPORTS FOR HIGHWAY SIGNS, LUMINAIRES, AND TRAFFIC SIGNALS, THE APPLICABLE PROVISIONS OF 1996 CONSTRUCTION AND TRAFFIC STANDARD DETAILS (AS RELATED TO TRAFFIC STANDARD DETAILS ONLY), AND THE 2017 CONSTRUCTION STANDARD DETAILS.
2. ALL WORK SHALL BE IN ACCORDANCE WITH THE 2021 MASSACHUSETTS STANDARD SPECIFICATIONS FOR HIGHWAYS AND BRIDGES, 2017 MassDOT CONSTRUCTION STANDARD DETAILS & THE 1996 CONSTRUCTION AND TRAFFIC STANDARD DETAILS (AS RELATED TO TRAFFIC STANDARD DETAILS ONLY).
3. THE TRAFFIC EQUIPMENT CABINET ANCHORAGE SHALL BE VERIFIED AND APPROVED BY THE ENGINEER PRIOR TO INSTALLATION TO BE AS SPECIFIED IN SECTION 815 OF THE STANDARD SPECIFICATIONS.
4. TRAFFIC CABINETS WALLS TO WHICH THE POST SHALL BE MOUNTED SHALL BE CONSTRUCTED OF, AT A MINIMUM, 12 GA. ASTM A366 SHEET STEEL HAVING AN ULTIMATE TENSILE STRENGTH (Fu) OF 43.0 KSI OR GREATER OR OF 1/8" THICK 5052 ALUMINUM.
5. CONNECTION DETAILS SHOWN ARE FOR A SINGLE SOLAR PANEL WITH MAXIMUM DIMENSIONS LIMITED TO 40"L x 20"W x 2"D. SOLAR PANELS EXCEEDING THESE DIMENSIONS SHALL REQUIRE SPECIAL INSTALLATION VERIFICATION.
6. MOUNTING POSTS SHALL BE FABRICATED FROM GALVANIZED SQUARE STEEL TUBE MEETING THE REQUIREMENTS OF ASTM A1011 WITH A MINIMUM YIELD STRENGTH OF 50 KSI AND SHALL CONFORM TO THE REQUIREMENTS OF SECTION M8.18.3, FOR TYPE P5 SIGN SUPPORTS AND SHALL BE GALV. IN ACCORDANCE WITH ASTM A653, COATING DESIGNATION G140 WITH A MINIMUM COATING THICKNESS OF 1.4 OZ/SF.
7. ALL MOUNTING BRACKETS AND HARDWARE SHALL BE H.D. GALV. IN ACCORDANCE WITH AASHTO M-232
8. GALVANIZED WASHERS SHALL BE PROVIDED UNDER THE NUTS FOR ALL MOUNTING BOLTS AT THE INTERIOR SIDE OF THE CABINET.
9. GALVANIZED ANGLE BRACKETS USED FOR PANEL ADJUSTMENTS SHALL BE AS RECOMMENDED BY THE MANUFACTURER AND SHALL BE MOUNTED TO THE CONNECTION BRACKET USING A MINIMUM OF FOUR (4) 1/4" OR LARGER GALVANIZED BOLTS.
10. A MINIMUM OF FOUR (4) 1/4" GALV. BOLTS SHALL BE USED TO SECURE THE SOLAR PANEL TO THE GALVANIZED ANGLE BRACKETS.

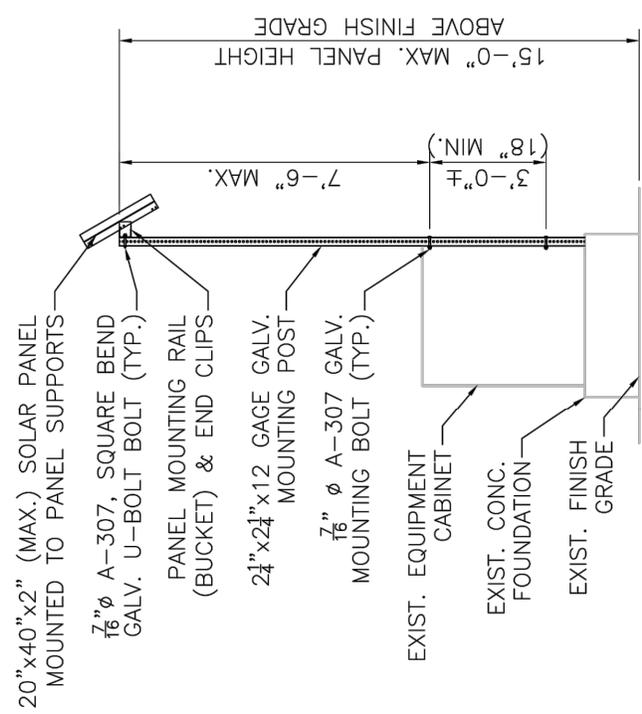

MOUNTING POST DETAIL ELEVATION VIEW

NO SCALE

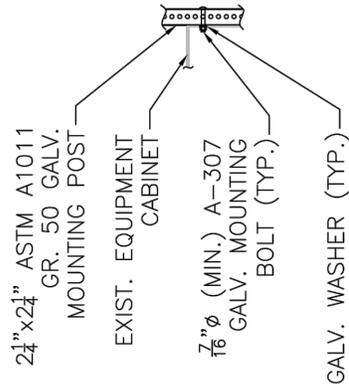

MOUNTING POST CONN. DETAIL

NO SCALE

ISSUED FOR CONSTRUCTION

**SOLAR PANEL INSTALLATION
TYPICAL MOUNTING DETAILS
TRAFFIC CABINET INSTALLATION**

10'-0" MAXIMUM MOUNTING HEIGHT

MASSACHUSETTS DEPARTMENT OF TRANSPORTATION
HIGHWAY DIVISION
10 PARK PLAZA BOSTON, MASS
MAY, 2021

SHEET 1 OF 1 SHEETS

MASSDOT
Highway Division
**HIGHWAY
DESIGN**

TRAFFIC DATA COLLECTION STATION - GENERAL

NOTES

DATE: 7/31/24

SCALE: NTS

PROJECT NO.: 612097

SHEET 17 OF 54

DECK REPAIR CONSTRUCTION NOTES

1. TEMPORARY BARRIER SHALL NOT BE USED FOR BRIDGE WORK. ALL PROPOSED WORK ON BRIDGES SHALL BE PERFORMED WITH SHORT-TERM OVERNIGHT LANE CLOSURES. ALL LANES MUST BE OPEN AT THE END OF THE WORK SHIFT IN THEIR ORIGINAL CONFIGURATION.
2. ALL EXISTING HOT MIX ASPHALT WEARING SURFACE AND MEMBRANE WATERPROOFING MATERIAL SHALL BE REMOVED IN EACH CONSTRUCTION STAGE PRIOR TO PERFORMING DECK REPAIRS.
3. THE EXPOSED DECK SURFACE SHALL BE INSPECTED BY THE ENGINEER TO DETERMINE THE APPROXIMATE LIMITS OF REPAIR, IN ADDITION AREAS OF THE UNDERSIDE WITH EVIDENCE OF DETERIORATION SHALL BE SOUNDED IN THE PRESENCE OF THE CONTRACTOR AND THE ENGINEER TO IDENTIFY AREAS IN NEED OF FULL DEPTH REPAIRS.
4. PRIOR TO ANY DECK EXCAVATION, THE CONTRACTOR MUST FURNISH A SHIELDING PLAN TO PREVENT EXCAVATED CONCRETE FROM FALLING ONTO THE ROADWAY BELOW. THIS PLAN MUST BE DESIGNED AND STAMPED BY A MASSACHUSETTS REGISTERED PROFESSIONAL ENGINEER OF THE APPROPRIATE DISCIPLINE. THE FURNISHING, INSTALLATION, AND REMOVAL OF SHIELDING SHALL BE PAID UNDER ITEM 994.1. AT THE DISCRETION OF THE ENGINEER, THE CONTRACTOR MAY UTILIZE CONSTRUCTION VEHICLES PARKED BELOW AREAS OF DECK EXCAVATION TO CATCH FALLING DEBRIS IN LIEU OF TRADITIONAL SHIELDING METHODS.
5. THE AREA TO BE REPAIRED SHALL BE STRAIGHT CUT PER ITEMS 127.4 AND 127.41, LOOSEN AND CHIP OUT TO SOUND CONCRETE SURFACE UNTIL MIN. OF 1" BELOW OR AROUND EXISTING TOP MAT OF REINFORCING STEEL. THE ENGINEER SHALL MAKE THE FINAL DETERMINATION OF THE DETERIORATED AREA TO BE REMOVED.
6. IF THE SOUND CONCRETE SURFACE IS LOCATED AT A DEPTH GREATER THAN 50% OF THE DECK THICKNESS WHEN MEASURED FROM THE TOP OF THE CONCRETE DECK, THE ENTIRE SLAB DEPTH SHALL BE EXCAVATED AND TREATED AS A FULL DEPTH REPAIR.
7. CLEAN EXISTING REINFORCING STEEL BARS AND EXCAVATED AREAS PRIOR TO REPLACING THE CONCRETE. NEW EPOXY COATED STEEL REINFORCEMENT SHALL BE PLACED TO SUPPLEMENT EXISTING REINFORCEMENT THAT HAS A SECTION LOSS OF 25% OR MORE OF THE ORIGINAL CROSS SECTION AREA OR HAS BROKEN, AS DETERMINED BY THE ENGINEER. NEW REINFORCEMENT SHALL EXTEND 30 BAR DIAMETERS IN EACH DIRECTION FROM WHERE THE SECTION LOSS OR BREAK ENDS. THE LIMITS OF EXCAVATION SHALL BE MODIFIED TO MEET THE REINFORCEMENT STEEL LAP SPLICE REQUIREMENTS. NEW REINFORCING STEEL SHALL BE PLACED AT THE SAME LEVEL ALONGSIDE THE EXISTING DETERIORATED OR BROKEN REINFORCING STEEL.
8. ALL EXISTING REINFORCING STEEL AND CONCRETE SURFACES THAT ARE TO BE IN CONTACT WITH REPAIR CONCRETE SHALL BE ABRASIVELY BLAST CLEANED IN ORDER TO REMOVE ALL RUST, OIL, AND DEBRIS THAT IS NOT TIGHTLY ADHERED, FOLLOWED BY APPLICATION OF COMPRESSED AIR TO REMOVE ALL DUST. THIS WORK SHALL BE INCIDENTAL TO ITEM 909.3.
9. THE TOP SURFACE OF THE DECK REPAIRS SHALL BE FINISHED FLUSH WITH THE ADJACENT TOP OF DECK SLAB AND SHALL MAINTAIN THE EXISTING GRADES AND CROSS SLOPES.
10. MAXIMUM CONSTRUCTION WIDTH BEYOND THE FASCIA BEAM SHALL BE LIMITED TO 4 FEET WITHOUT THE OVERHANG BEING SUPPORTED FOR BOTH FULL DEPTH AND PARTIAL DEPTH REPAIRS. THE CONTRACTOR IS REQUIRED TO PROVIDE A DESIGN CAPACITY CHECK FOR ONE FOOT SLAB WIDTH LOADING FOR THE OVERHANG IF HE CHOOSES TO GO BEYOND THE FOUR FOOT MAXIMUM SLAB WIDTH STATED ABOVE, THE DESIGN CHECK SHALL BE DONE AND STAMPED BY A MASSACHUSETTS REGISTERED PROFESSIONAL ENGINEER.
11. DECK FORMS SHALL BE FLUSH WITH THE EXISTING DECK UNDERSIDE AND SHALL BE REMOVED AFTER CURING IS COMPLETE.
12. NO PORTION OF THE CONCRETE BRIDGE DECK SHALL BE EXPOSED TO LIVE TRAFFIC FOR MORE THAN 14 CALENDAR DAYS PRIOR TO FINAL PAVING. NO PORTION OF THE MILLED BRIDGE DECK SHALL BE EXPOSED TO LIVE TRAFFIC FOR MORE THAN 7 CALENDAR DAYS BEFORE FINAL PAVING. WHEN NECESSARY TO MEET THE 14-DAY REQUIREMENT, THE CONTRACTOR MAY BE REQUIRED TO PHASE THE WORK, LIMITING PAVEMENT REMOVAL TO ONE LANE AT A TIME.
13. UPON COMPLETION OF ALL DECK REPAIRS, THE DECK SHALL BE ABRASIVELY BLAST CLEANED AND RESURFACED WITH SUPERPAVE WATERPROOFING SURFACE COURSE. ALL EXISTING SHIELDING SHALL BE RETAINED AND CLEANED OF DEBRIS AFTER PROJECT COMPLETION. IF REQUIRED, REMOVAL AND REINSTALLATION OF EXISTING SHIELDING SHALL BE CONSIDERED INCIDENTAL TO THE WORK.



BRIDGE WORK NOTES

BRIDGES: W-21-045, W-21-046, W-21-047,
& C-13-034=W-21-043

DATE: 4/15/24

SCALE: NTS

PROJECT NO.: 612097

SHEET 18 OF 54

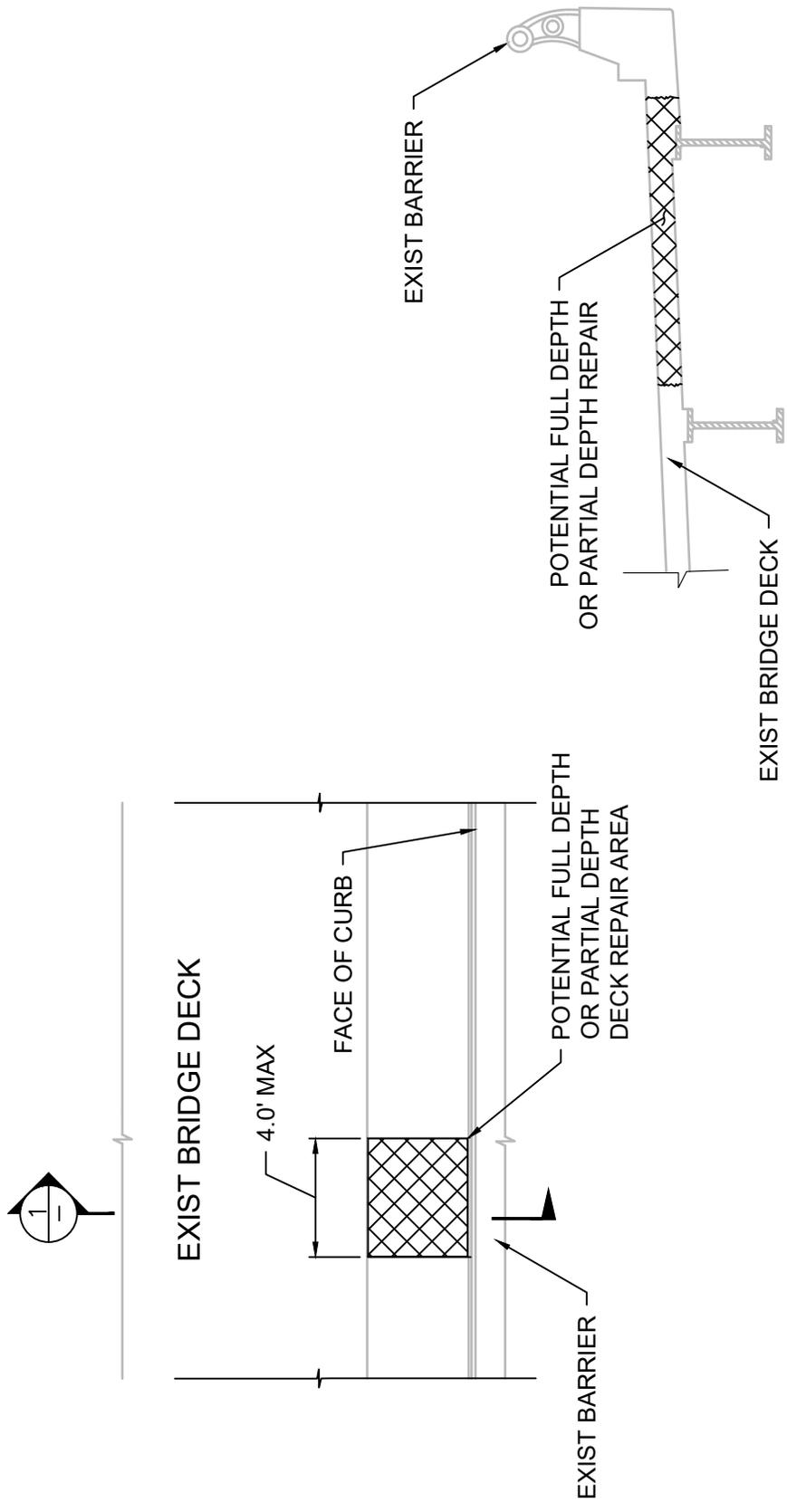

DECK REPAIR AT OVERHANG
 BRIDGE: W-21-045, W-21-046, W-21-047

DATE: 1/10/2024

SCALE: NTS

PROJECT NO.: 612097

SHEET 19 OF 54

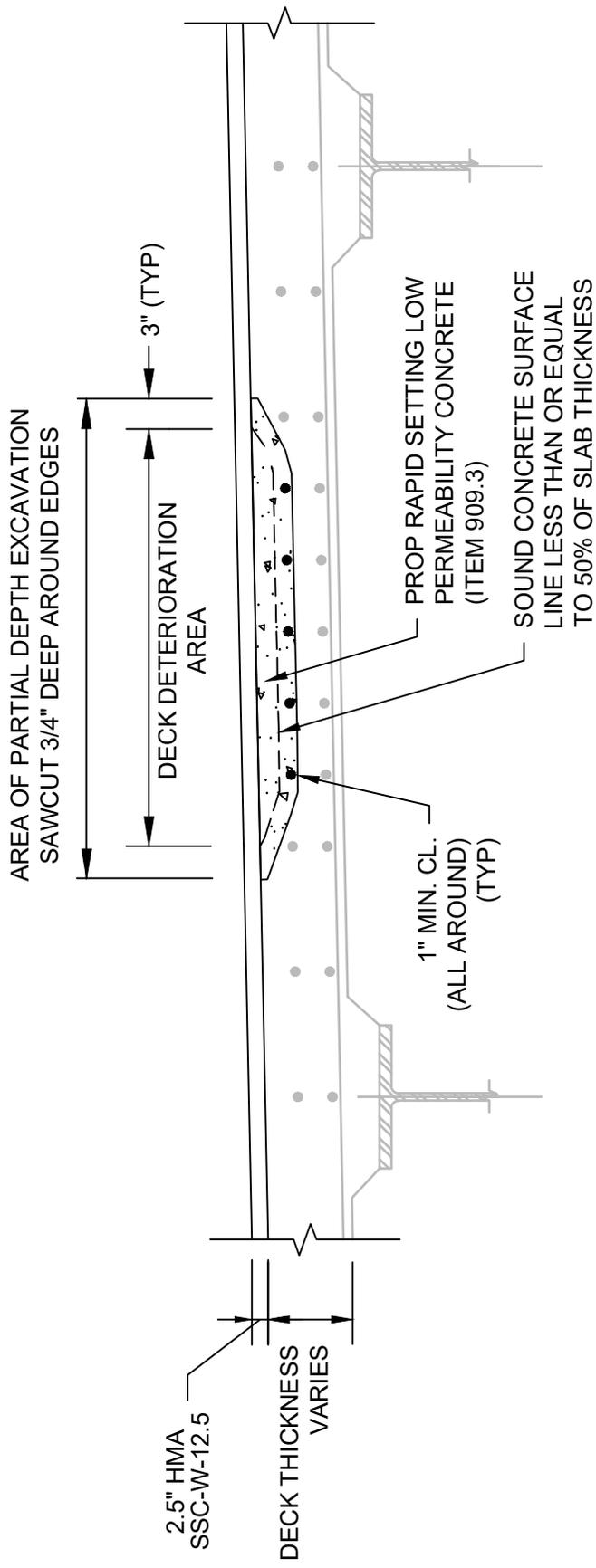

DATE:	1/10/2024
SCALE:	NTS
PROJECT NO.:	612097
SHEET	20 OF 54

TYPICAL PARTIAL DEPTH BRIDGE DECK
BRIDGE: W-21-045, W-21-046, W-21-047



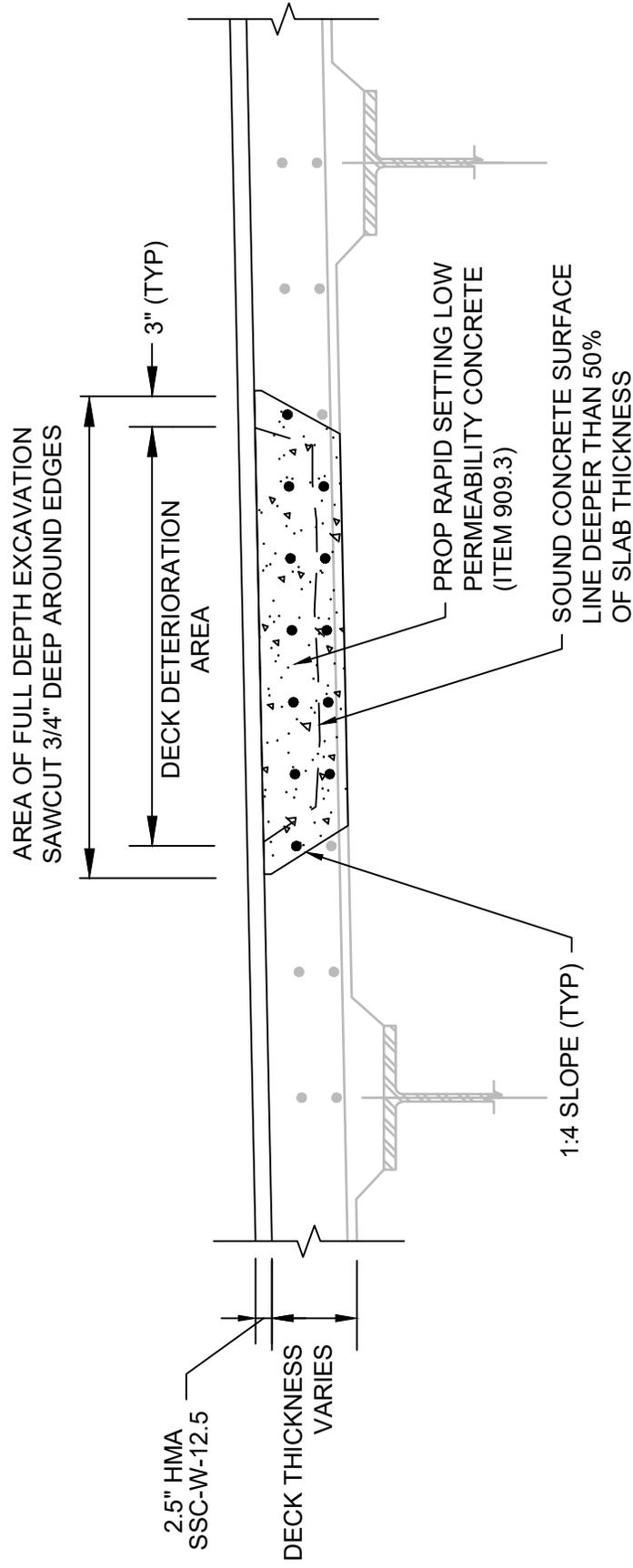

DATE:	1/10/2024
SCALE:	NTS
PROJECT NO.:	612097
SHEET	21 OF 54

TYPICAL FULL DEPTH BRIDGE DECK

BRIDGE: W-21-045, W-21-046, W-21-047



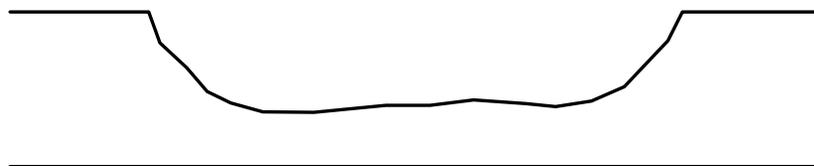

MATCH EXIST SIZE AND SPACING



STEEL REINFORCEMENT REPAIR

BRIDGE: W-21-045, W-21-046, W-21-047

DATE: 4/15/24

SCALE: NTS

PROJECT NO.: 612097

SHEET 22 OF 54

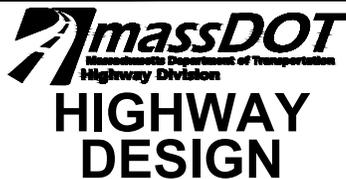
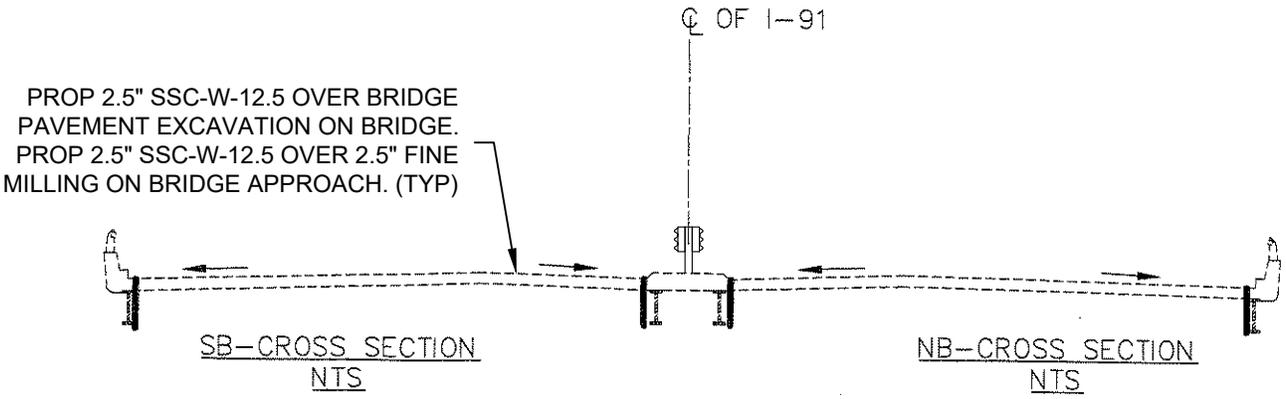
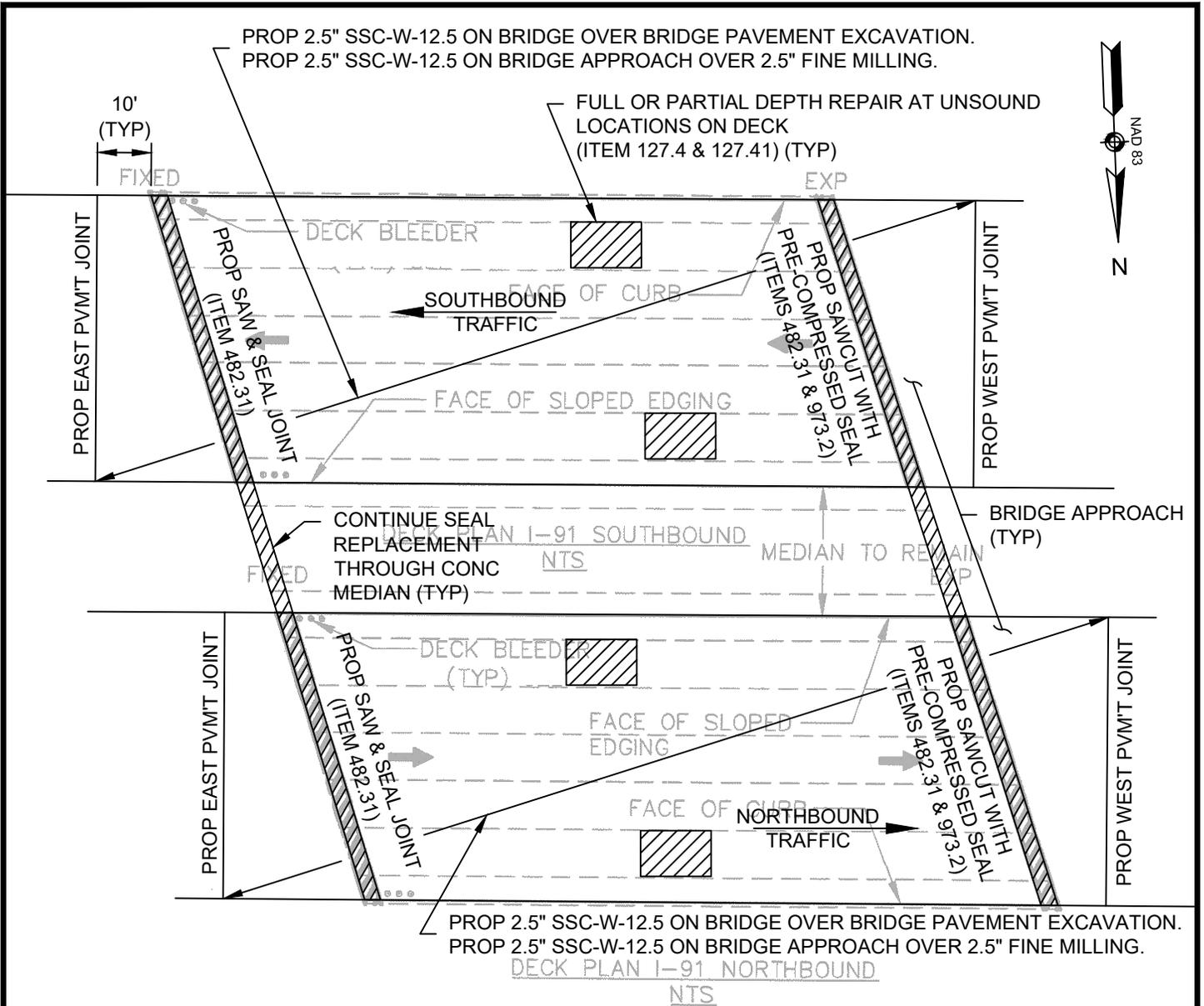

BRIDGE DECK PLAN

W-21-045

DATE: 1/9/24

SCALE: NTS

PROJECT NO.: 612097

SHEET 23 OF 54

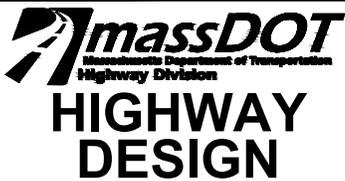
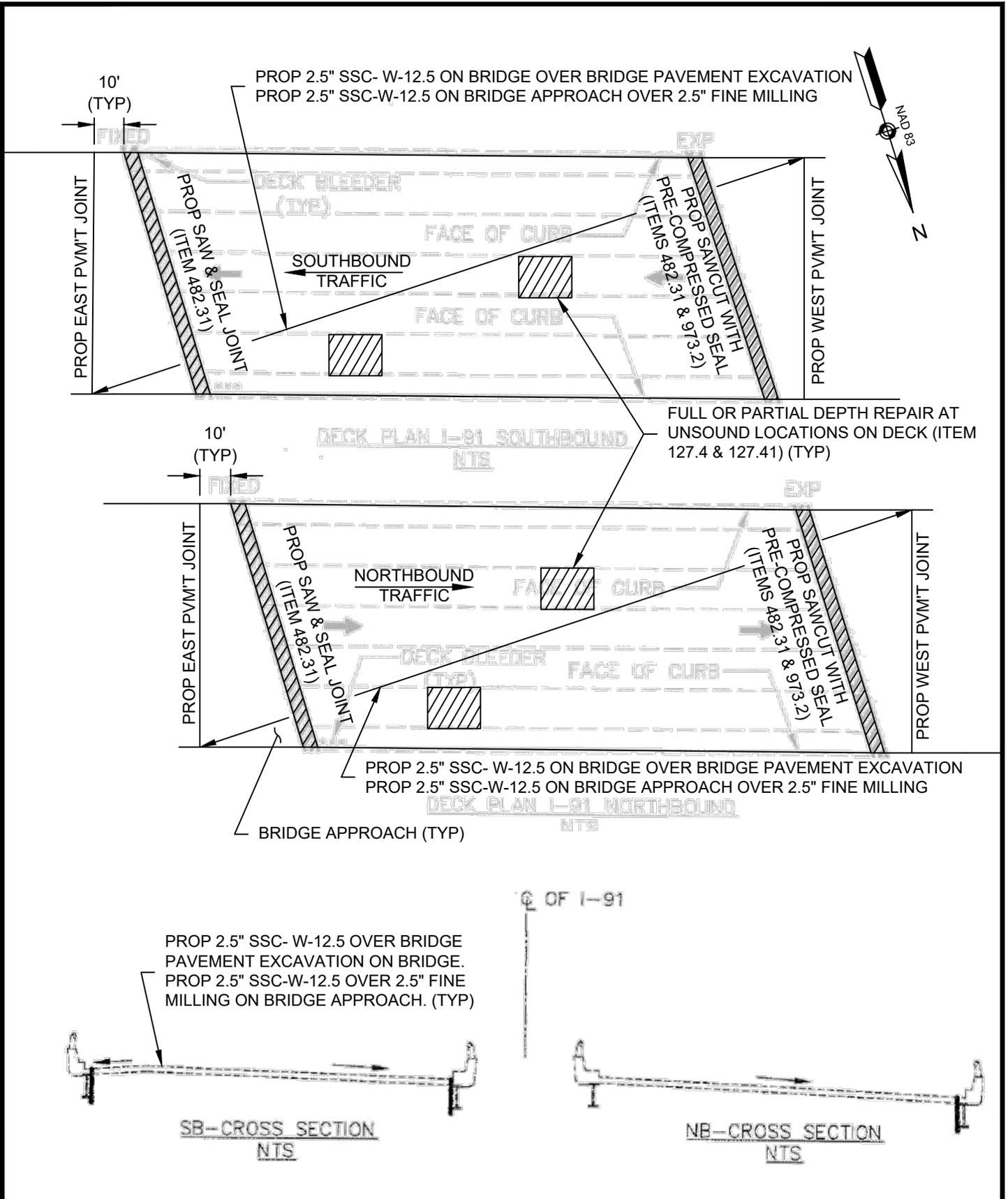

BRIDGE DECK PLAN

W-21-046

DATE: 1/9/24

SCALE: NTS

PROJECT NO.: 612097

SHEET 24 OF 54

PROPOSED LOCATIONS
 W-21-045 - WEST ABUTMENT
 W-21-046 - WEST ABUTMENTS

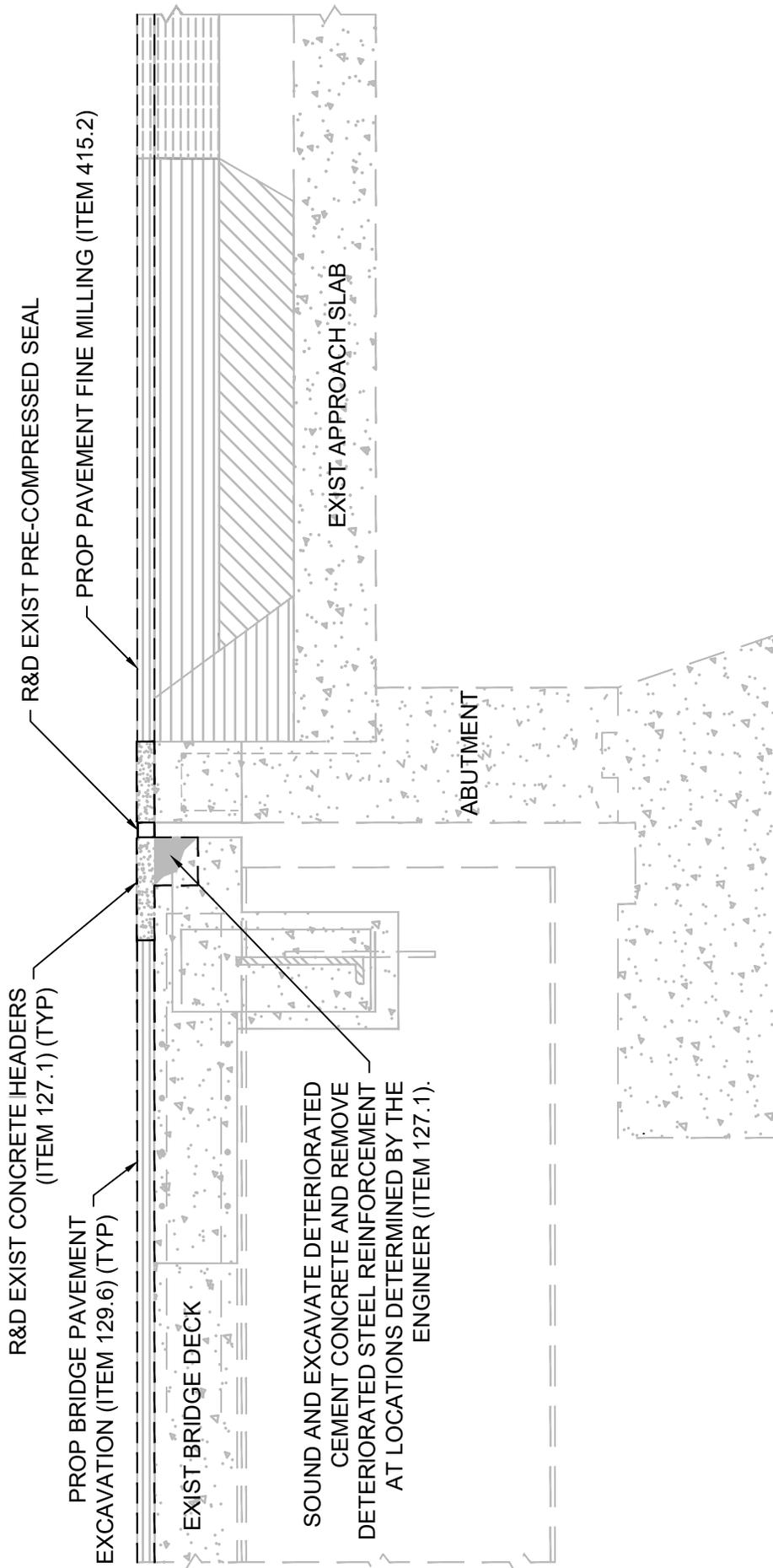

**PROP LIMITS OF BRIDGE JOINT EXCAVATION
 AT ABUTMENT
 (W-21-045, W-21-046)**

DATE:	1/8/2024
SCALE:	NTS
PROJECT NO.:	612097
SHEET	25 OF 54

PROPOSED LOCATIONS
 W-21-045 - WEST ABUTMENT
 W-21-046 - WEST ABUTMENTS

PROP SAWCUT WITH PRE-COMPRESSED SEAL
 (ITEMS 482.31 & 973.1)
 (SEE SHEETS 27 AND 31)

PROP 2.5" SUPERPAVE WATERPROOFING SURFACE
 COURSE - 12.5 (SSC-W-12.5) (ITEM 457.2)

PROP 2.5" SUPERPAVE WATERPROOFING
 SURFACE COURSE - 12.5 (SSC-W-12.5) (ITEM 457.2)

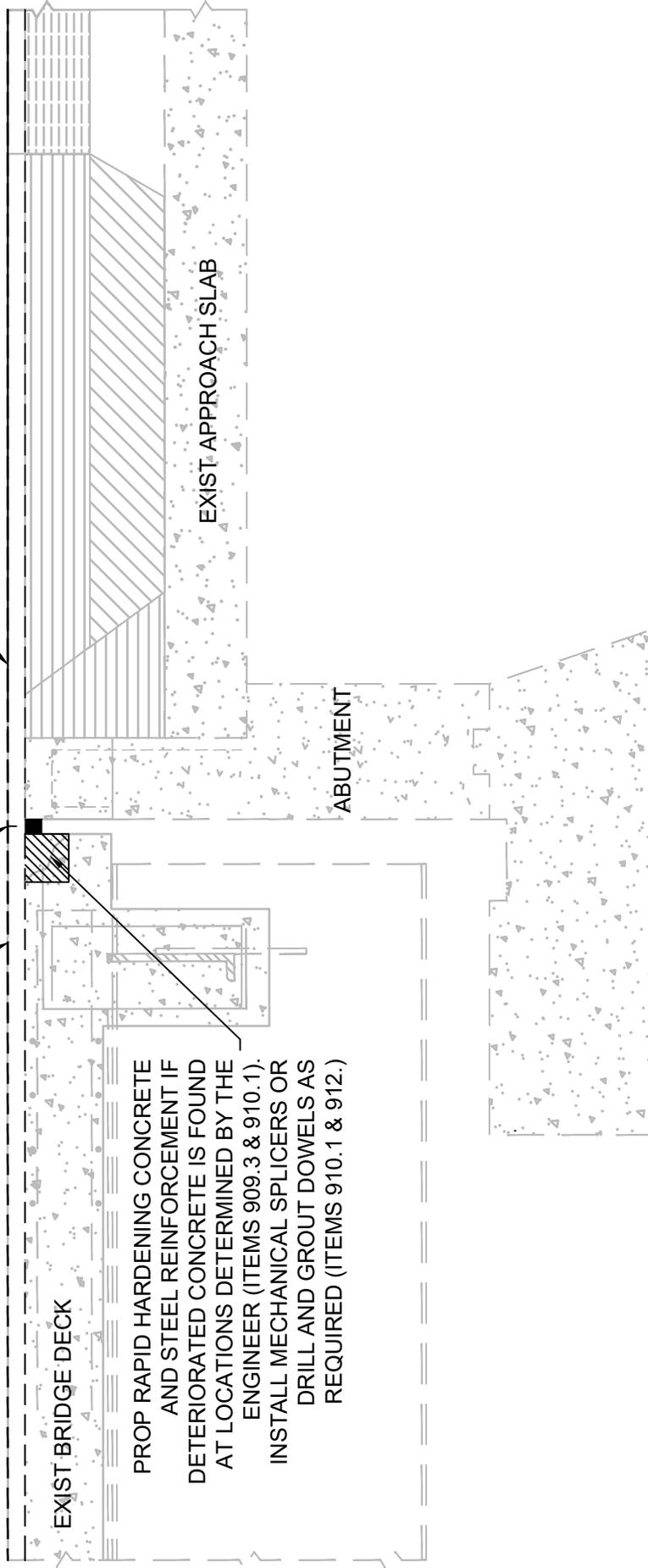

EXIST BRIDGE DECK

PROP RAPID HARDENING CONCRETE
 AND STEEL REINFORCEMENT IF
 DETERIORATED CONCRETE IS FOUND
 AT LOCATIONS DETERMINED BY THE
 ENGINEER (ITEMS 909.3 & 910.1).
 INSTALL MECHANICAL SPLICERS OR
 DRILL AND GROUT DOWELS AS
 REQUIRED (ITEMS 910.1 & 912.)

EXIST APPROACH SLAB

ABUTMENT



SAWCUT WITH PRE-COMPRESSED SEAL AT ABUTMENT
 (W-21-045, W-21-046)

DATE: 1/8/2024

SCALE: NTS

PROJECT NO.: 612097

SHEET 26 OF 54

12" WIDE STRIP OF PREFORMED
SHEET WATERPROOFING
MEMBRANE CENTERED OVER JOINT

6" (TYP)

BRIDGE NO.	TRIBUTARY THERMAL EXPANSION/CONTRACTION LENGTH	JOINT GAP (X) @ 70°F	NOMINAL JOINT SEAL WIDTH
W-21-045 WEST ABUTMENT	65	1"	1.5"
W-21-046 WEST ABUTMENT	66	1"	1.5"



**SAWCUT WITH PRE-COMPRESSED
SEAL**

W-21-045, W-21-046

DATE: 10/30/24

SCALE: NTS

PROJECT NO.: 612097

SHEET 27 OF 54

PROPOSED LOCATIONS:
 W-21-045 - WEST ABUTMENT
 W-21-046 - WEST ABUTMENT

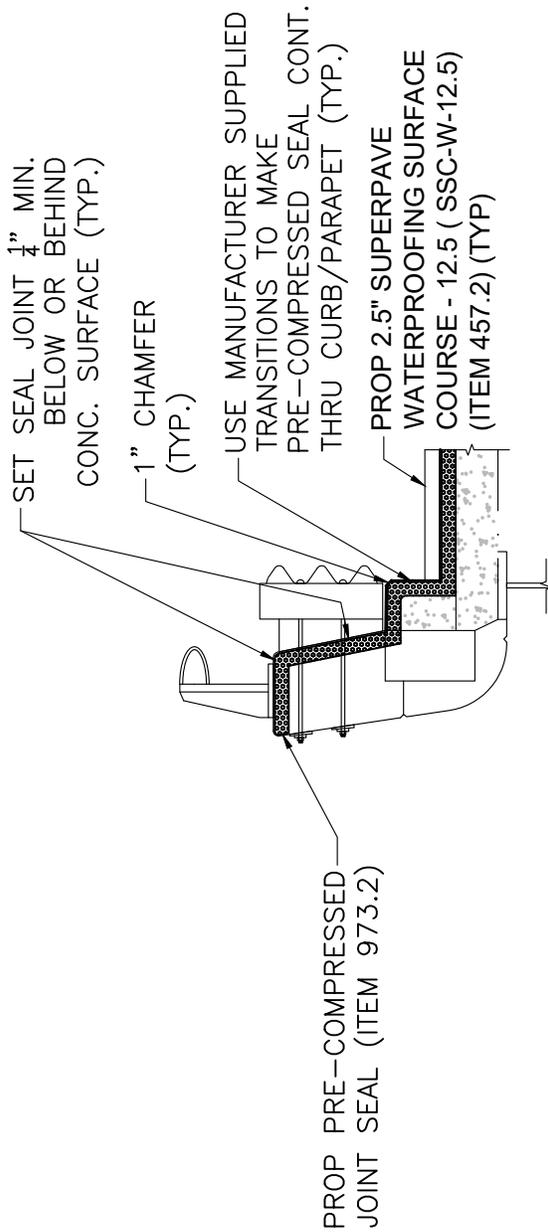

PRE-COMPRESSED SEAL AT PARAPET

NOT TO SCALE

NOTES:

- 1). SEE PRE-COMPRESSED JOINT SEAL DETAIL.
- 2). CLEAN JOINT PRIOR TO INSTALLATION OF NEW PRE-COMPRESSED JOINT SEAL.
- 3). REPAIR PARAPET PRIOR TO INSTALLATION OF NEW PRE-COMPRESSED JOINT SEAL AS DIRECTED BY THE ENGINEER.



SAWCUT WITH PRE-COMPRESSED SEAL

W-21-045, W-21-046

DATE: 1/10/2024

SCALE: NTS

PROJECT NO.: 612097

SHEET 28 OF 54

PRE-COMPRESSED SEAL JOINT NOTES

1. THE INSTALLATION AND SPLICING OF THE PRE-COMPRESSED SEAL SHALL FOLLOW THE MANUFACTURER'S INSTRUCTIONS.
2. THE JOINT SYSTEM INSTALLATION SHALL TAKE PLACE AFTER THE DECK REPAIR MATERIAL ADJACENT TO THE JOINT OPENING HAS SUFFICIENTLY CURED.
3. THE JOINT OPENING SHALL BE FREE OF ALL CONTAMINANTS SUCH AS GREASE, DUST, AND DIRT. PRIOR TO JOINT SYSTEM INSTALLATION, THE JOINT WALLS SHALL BE BLOWN CLEAN WITH OIL-FREE COMPRESSED AIR AND WIPED CLEAN WITH A CLEAN WET CLOTH TO THE BOTTOM OF THE PRE-COMPRESSED SEAL MATERIAL PLUS 1" TO REMOVE ANY DUST REMAINING. THE SUBSTRATE PREP SHALL FOLLOW THE ICRI CONCRETE SURFACE PROFILE STANDARDS TO ACHIEVE A SURFACE PROFILE OF CSP 2 (MIN.) OR 3 (PREFERRED) IN ORDER TO ACCEPT THE JOINT SYSTEM.
4. THE PRE-COMPRESSED SEAL JOINT SYSTEM SHALL BE CONTINUOUS THROUGH CURBS, MEDIANS, AND PARAPETS AS APPROPRIATE TO THE CONDITIONS AT HAND. CONTINUITY OF SEAL SHALL BE ACHIEVED THROUGH THE USE OF FACTORY-FABRICATED UNIVERSAL OR CUSTOM TRANSITIONS SUPPLIED BY THE PRE-COMPRESSED JOINT SEAL MANUFACTURER. THE FIELD SPLICE OF THE PRE-COMPRESSED SEAL SHALL BE DONE IN ACCORDANCE WITH THE MANUFACTURER'S RECOMMENDATIONS.

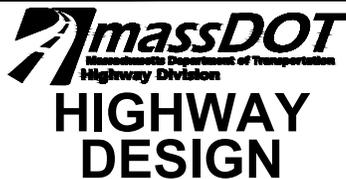

PRE-COMPRESSED SEAL JOINT NOTES

W-21-045, W-21-046

DATE: 4/15/24

SCALE: NTS

PROJECT NO.: 612097

SHEET 29 OF 54

PROPOSED LOCATIONS:
 W-21-045 - EAST ABUTMENT
 W-21-046 - EAST ABUTMENT

PROP SAW & SEAL JOINT (ITEM 482.31)
 (SEE FOLLOWING SHEET FOR DETAIL)

PROP 2.5" SUPERPAVE WATERPROOFING
 SURFACE COURSE - 12.5 (SSC-W-12.5)
 (ITEM 457.2) (TYP)

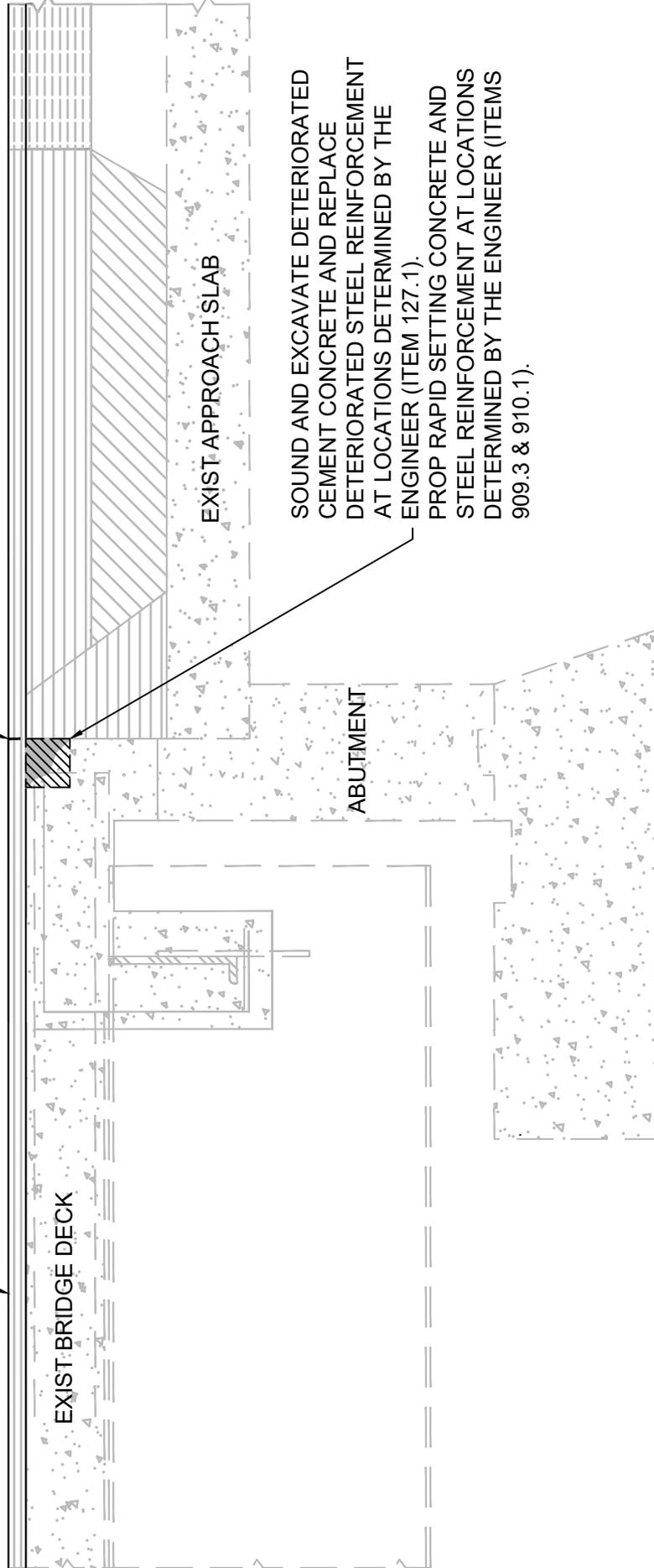

SAW AND SEAL JOINT AT ABUTMENT

W-21-045, W-21-046

DATE: 1/10/2024

SCALE: NTS

PROJECT NO.: 612097

SHEET 30 OF 54

PROPOSED LOCATIONS:
 W-21-045 - EAST ABUTMENT
 W-21-046 - EAST ABUTMENT

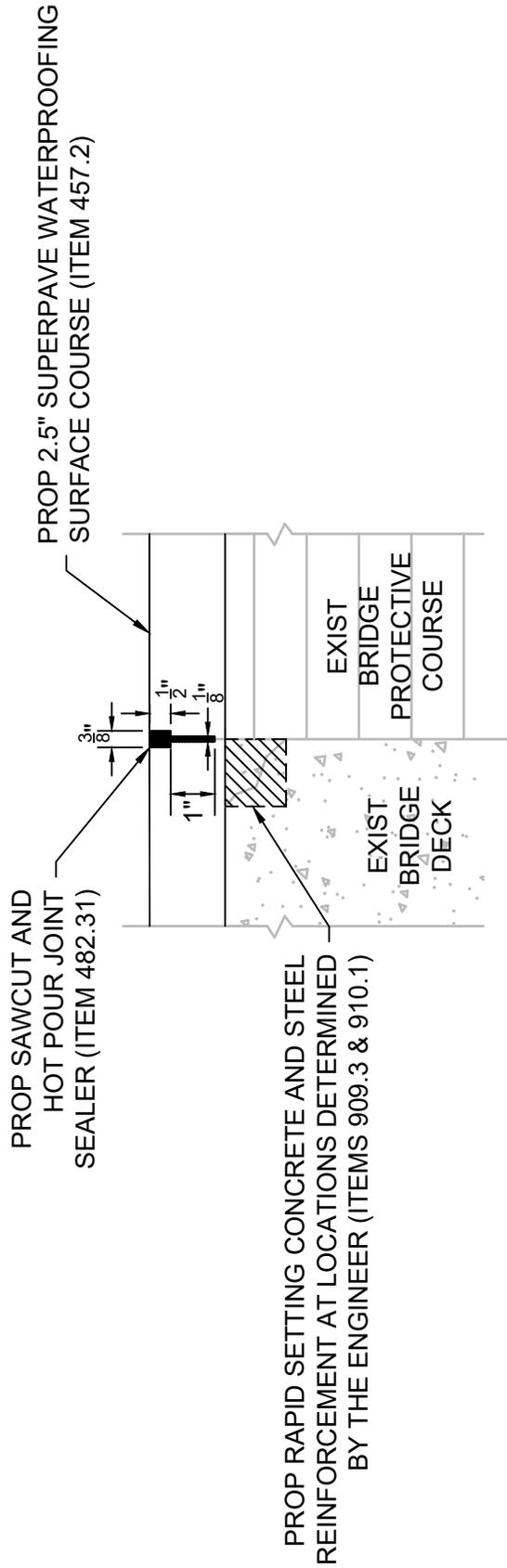

SAW AND SEAL JOINT DETAIL (ITEM 482.31)

W-21-045, W-20-046

DATE: 1/10/2024

SCALE: NTS

PROJECT NO.: 612097

SHEET 31 OF 54

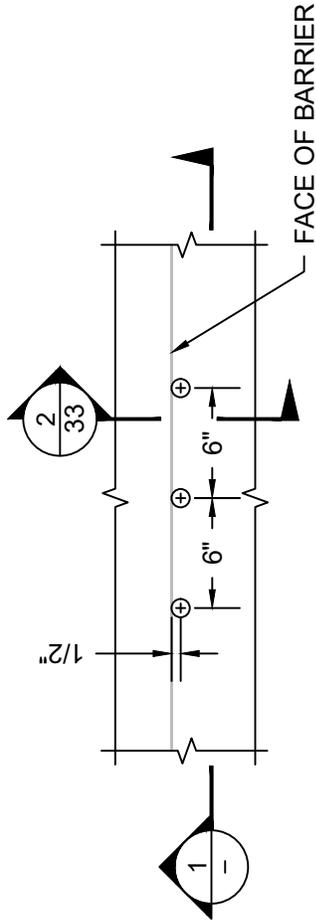

PLAN VIEW

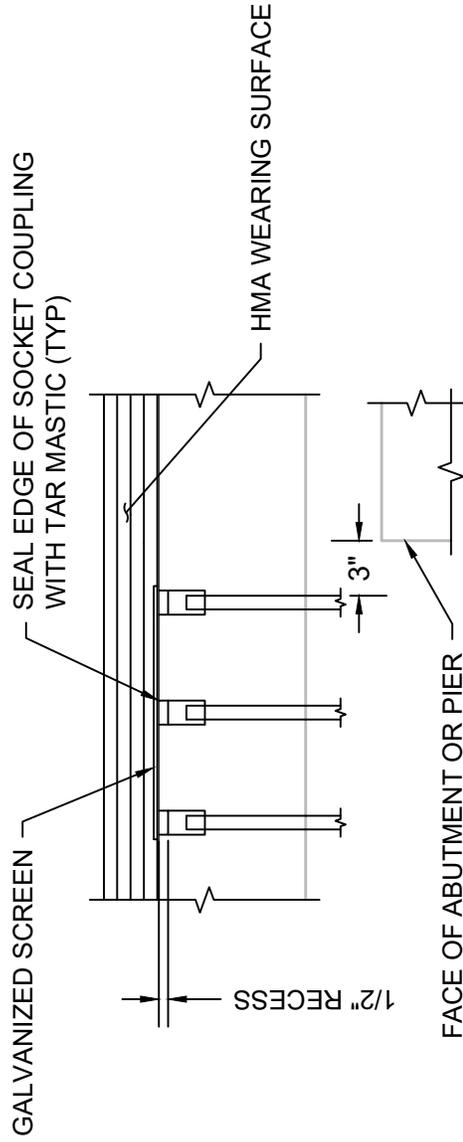

SECTION 1

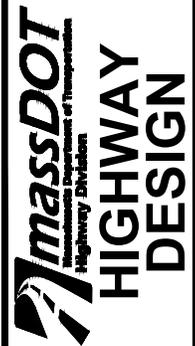

BRIDGE DECK BLEEDER DETAIL (ITEM 106.15)

W-21-045, W-21-046

DATE: 1/10/2024

SCALE: NTS

PROJECT NO.: 612097

SHEET 32 OF 54

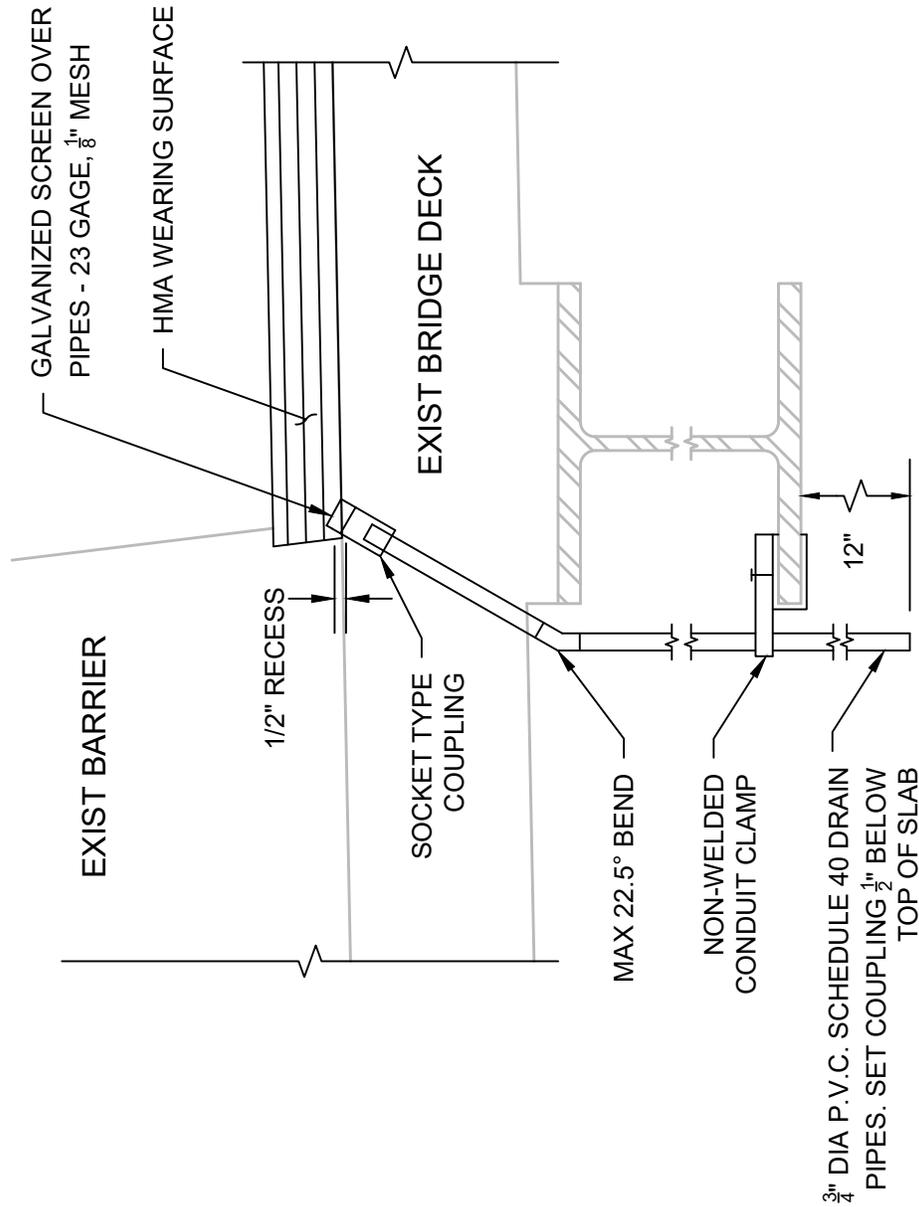

SECTION 2

DATE:	1/10/2024
SCALE:	NTS
PROJECT NO.:	612097
SHEET	33 OF 54

BRIDGE DECK BLEEDER DETAIL (ITEM 106.15)

W-21-045, W-21-046



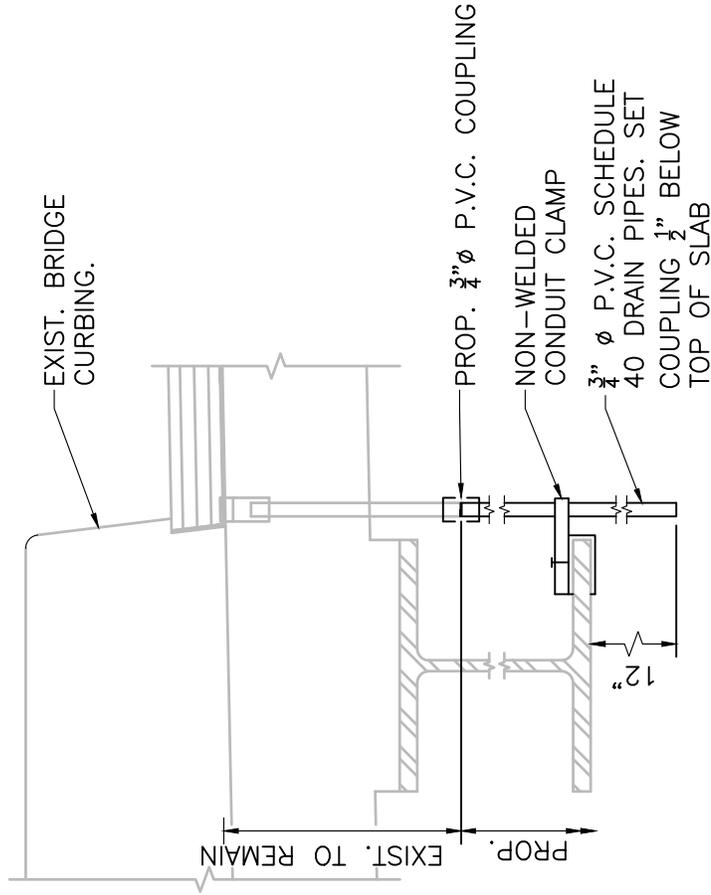

PVC DRAIN PIPE EXTENSIONS

SCALE: NTS



BRIDGE DECK BLEEDER EXTENSION (ITEM 106.151)

BRIDGE: W-21-045, W-21-046

DATE: 1/10/2024

SCALE: NTS

PROJECT NO.: 612097

SHEET 34 OF 54

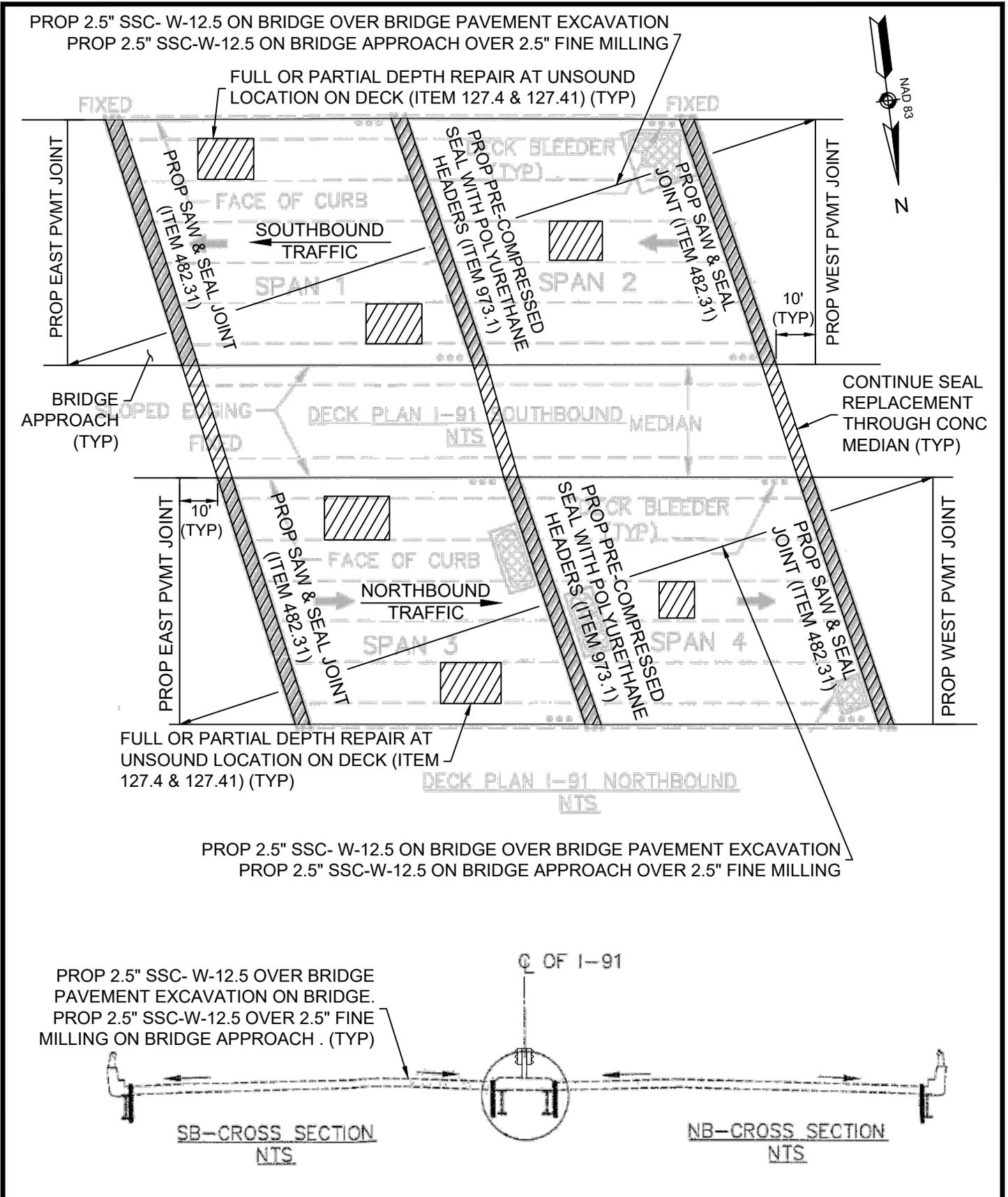

BRIDGE DECK PLAN
W-21-047

DATE: 1/9/24
SCALE: NTS
PROJECT NO.: 612097
SHEET 35 OF 54

PROPOSED LOCATION:
W-21-047 - CENTER PIER

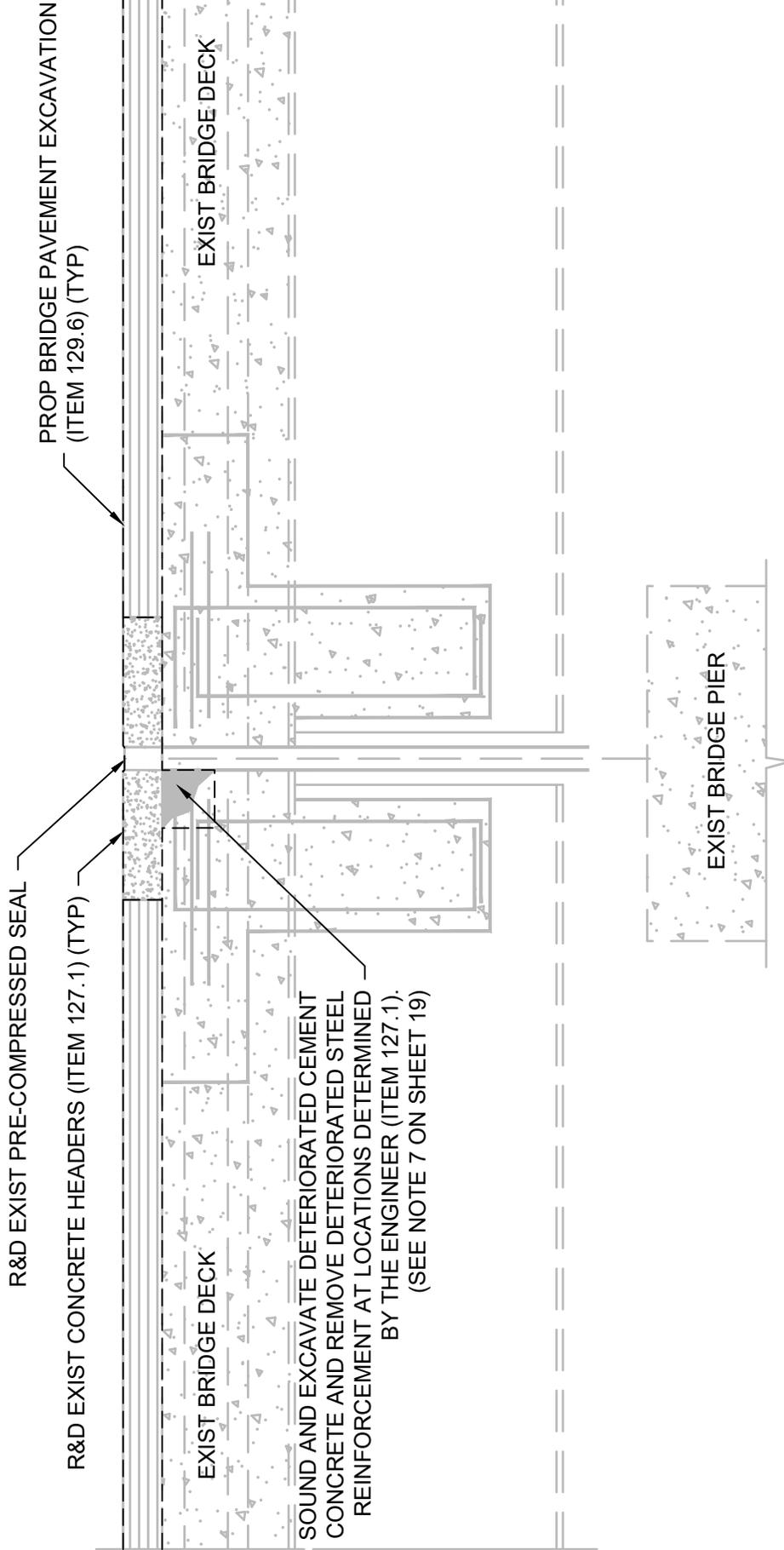

**PROP LIMITS OF BRIDGE JOINT
EXCAVATION AT PIER (W-21-047)**

DATE:	1/8/2024
SCALE:	NTS
PROJECT NO.:	612097
SHEET	36 OF 54

PROPOSED LOCATION:
W-21-047 - CENTER PIER

PROP PRE-COMPRESSED JOINT SEAL WITH POLYURETHANE
RESIN CONCRETE HEADERS (ITEM 973.1) (TYP)

PROP 2.5" SUPERPAVE WATERPROOFING
SURFACE COURSE - 12.5 (SSC-W-12.5)
(ITEM 457.2) (TYP)

6"
(TYP)

EXIST BRIDGE DECK

EXIST BRIDGE DECK

PROP RAPID HARDENING CONCRETE AND STEEL
REINFORCEMENT AT LOCATIONS DETERMINED
BY THE ENGINEER (ITEMS 909.3 & 910.1)

EXIST BRIDGE PIER



**PRE-COMPRESSED JOINT SEAL WITH POLYURETHANE
RESIN CONCRETE HEADERS AT PIER (W-21-047)**

DATE: 1/8/2024

SCALE: NTS

PROJECT NO.: 612097

SHEET 37 OF 54

PRE-COMPRESSED SEAL JOINT NOTES

1. THE INSTALLATION AND SPLICING OF THE PRE-COMPRESSED SEAL SHALL FOLLOW THE MANUFACTURER'S INSTRUCTIONS.
2. THE JOINT SYSTEM INSTALLATION SHALL TAKE PLACE AFTER THE DECK REPAIR MATERIAL ADJACENT TO THE JOINT OPENING HAS SUFFICIENTLY CURED.
3. THE JOINT OPENING SHALL BE FREE OF ALL CONTAMINANTS SUCH AS GREASE, DUST, AND DIRT. PRIOR TO JOINT SYSTEM INSTALLATION, THE JOINT WALLS SHALL BE BLOWN CLEAN WITH OIL-FREE COMPRESSED AIR AND WIPED CLEAN WITH A CLEAN WET CLOTH TO THE BOTTOM OF THE PRE-COMPRESSED SEAL MATERIAL PLUS 1" TO REMOVE ANY DUST REMAINING. THE SUBSTRATE PREP SHALL FOLLOW THE ICRI CONCRETE SURFACE PROFILE STANDARDS TO ACHIEVE A SURFACE PROFILE OF CSP 2 (MIN.) OR 3 (PREFERRED) IN ORDER TO ACCEPT THE JOINT SYSTEM.
4. THE PRE-COMPRESSED SEAL JOINT SYSTEM SHALL BE CONTINUOUS THROUGH CURBS, MEDIANS, AND PARAPETS AS APPROPRIATE TO THE CONDITIONS AT HAND. CONTINUITY OF SEAL SHALL BE ACHIEVED THROUGH THE USE OF FACTORY-FABRICATED UNIVERSAL OR CUSTOM TRANSITIONS SUPPLIED BY THE PRE-COMPRESSED JOINT SEAL MANUFACTURER. THE FIELD SPLICE OF THE PRE-COMPRESSED SEAL SHALL BE DONE IN ACCORDANCE WITH THE MANUFACTURER'S RECOMMENDATIONS.
5. THE HEADER CONCRETE SHALL CONSIST OF POLYURETHANE RESIN AND AGGREGATE THAT CONSISTS OF SAND AND CHOPPED FIBERGLASS. THE RATIO OF AGGREGATE TO RESIN BY WEIGHT SHALL NOT EXCEED 2. SEE SPECIAL PROVISIONS.
6. THE HEADER CONCRETE SHALL BE SUFFICIENTLY CURED SO THAT VEHICULAR TRAFFIC MAY BE APPLIED IN NO MORE THAN 2 HOURS AFTER MIXING AND PLACEMENT.

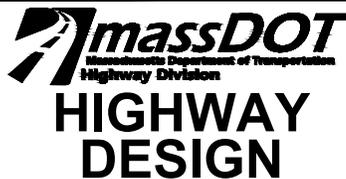

**PRE-COMPRESSED SEAL JOINT
NOTES**
W-21-047

DATE: 4/15/24
SCALE: NTS
PROJECT NO.: 612097
SHEET 38 OF 54

PROPOSED LOCATIONS:
W-21-047 - EAST & WEST ABUTMENTS

PROP SAW & SEAL JOINT (ITEM 482.31)
(SEE FOLLOWING SHEET FOR DETAIL)

PROP 2.5" SUPERPAVE
WATERPROOFING SURFACE
COURSE - 12.5 (SSC-W-12.5) (TYP)

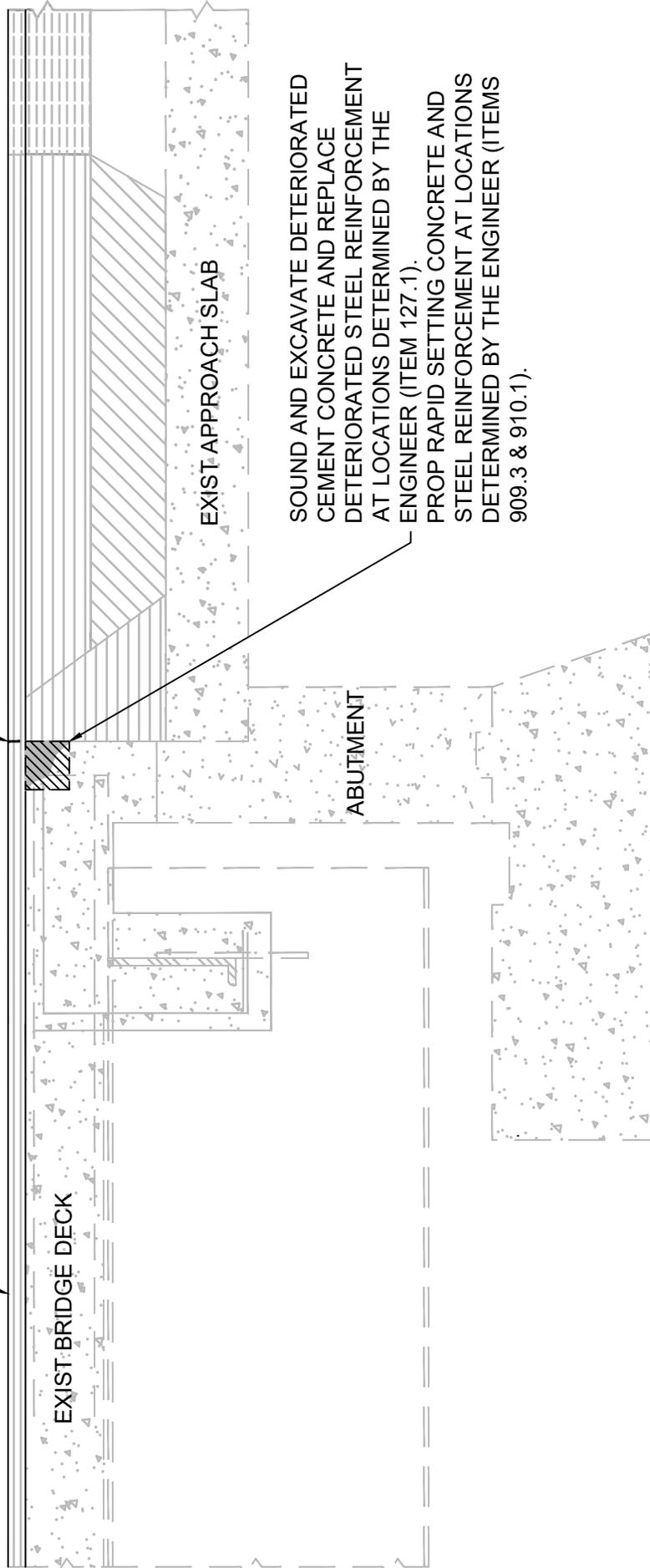

SAW AND SEAL JOINT AT ABUTMENT

W-21-047

DATE: 1/10/2024

SCALE: NTS

PROJECT NO.: 612097

SHEET 39 OF 54

PROPOSED LOCATIONS:
W-21-047 - EAST & WEST ABUTMENTS

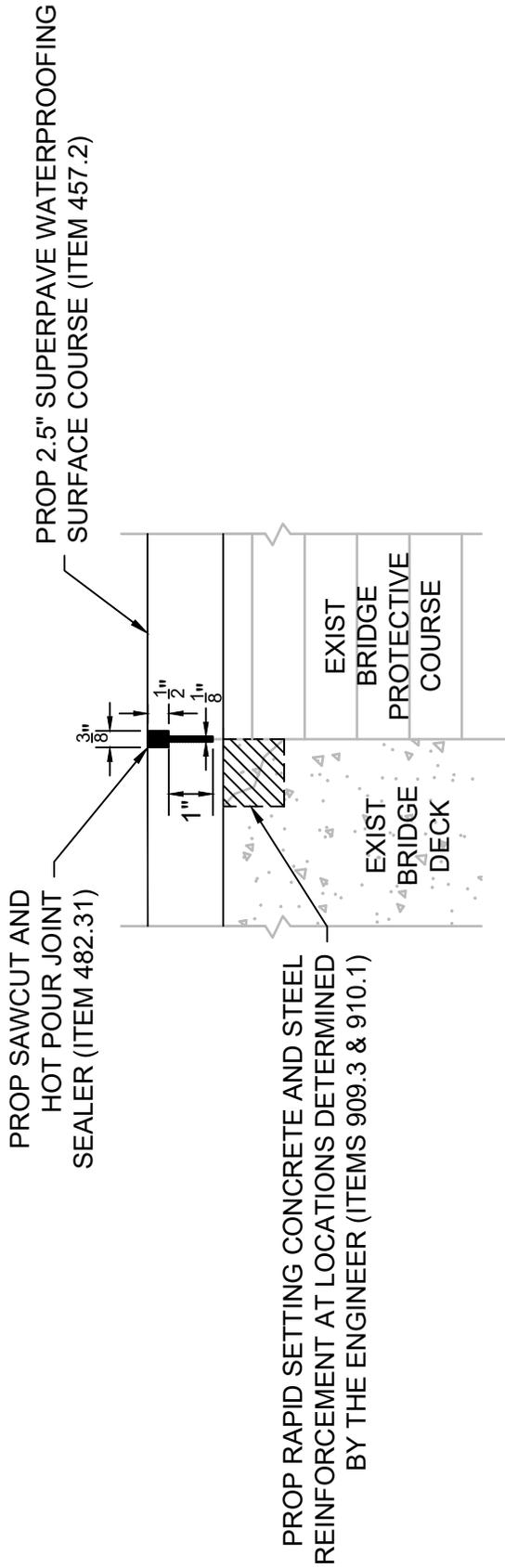

SAW AND SEAL JOINT AT ABUTMENT

W-21-047

DATE: 1/10/2024

SCALE: NTS

PROJECT NO.: 612097

SHEET 40 OF 54

PROPOSED LOCATIONS:
W-21-047 - CENTER PIER

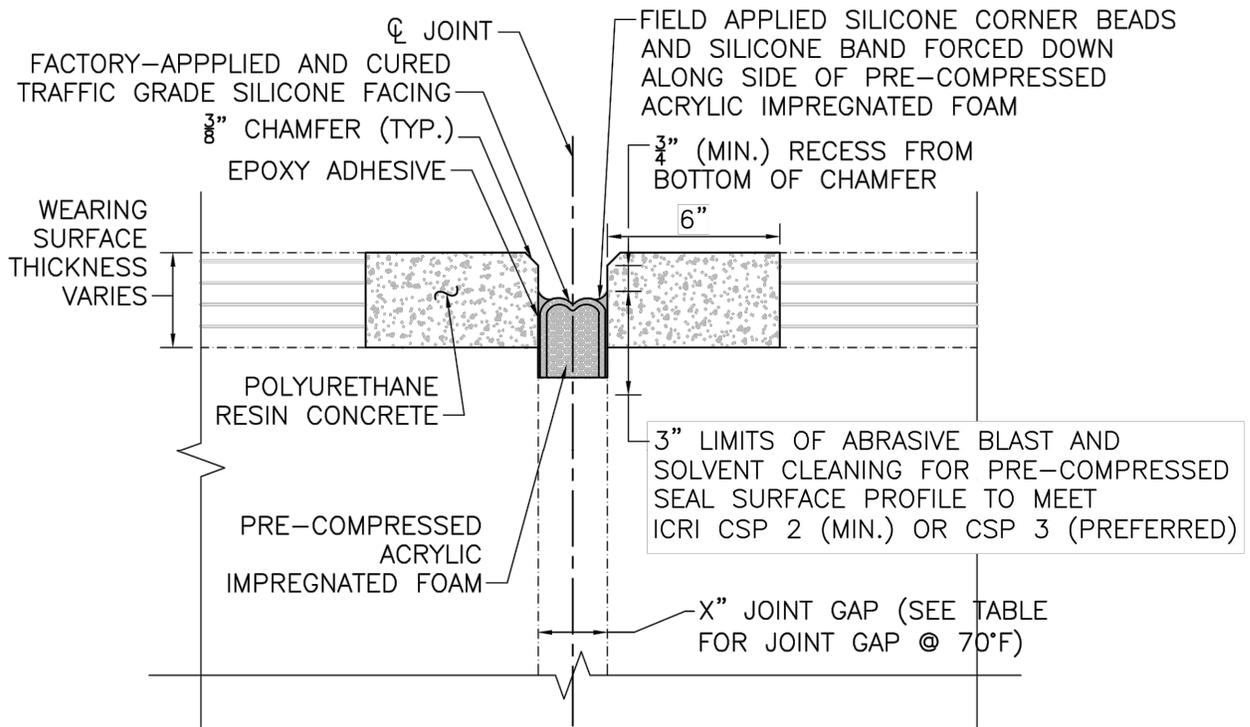

BRIDGE NO.	TRIBUTARY THERMAL EXPANSION/CONTRACTION LENGTH	JOINT GAP (X) @ 70°F	NOMINAL JOINT SEAL WIDTH
W-21-047 (CENTER PIER)	123'	1.5"	2"



PRE-COMPRESSED SEAL
SECTION
W-21-047

DATE: 4/15/24
SCALE: NTS
PROJECT NO.: 612097
SHEET 41 OF 54

PROPOSED LOCATIONS:
W-21-047 - CENTER PIER

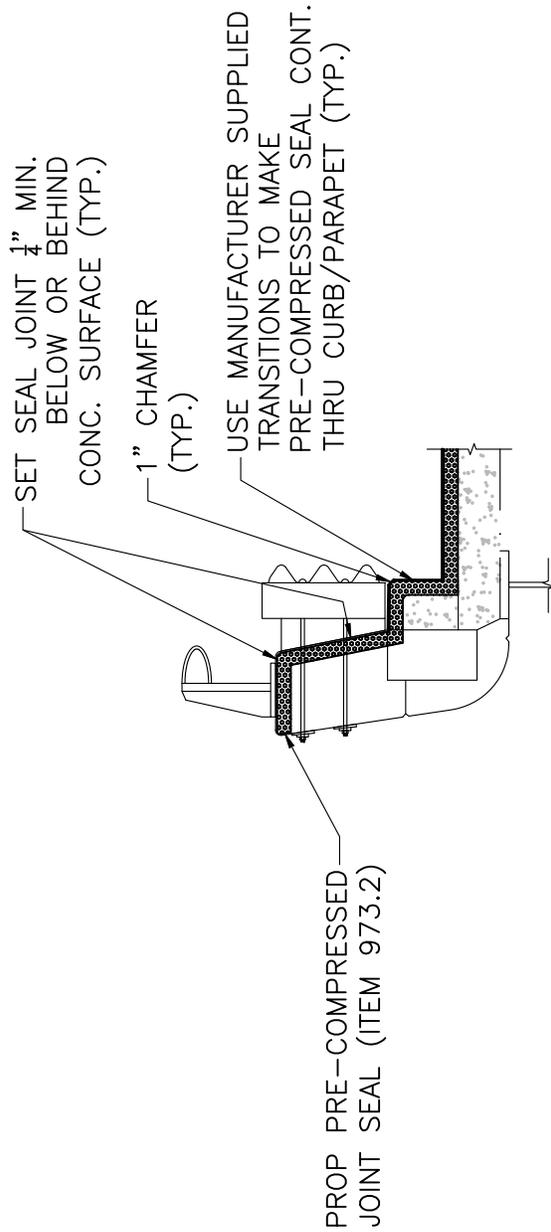

PRE-COMPRESSED SEAL AT PARAPET

NOT TO SCALE

NOTES:

- 1). SEE PRE-COMPRESSED JOINT SEAL DETAIL.
- 2). CLEAN JOINT PRIOR TO INSTALLATION OF NEW PRE-COMPRESSED JOINT SEAL.
- 3). REPAIR PARAPET PRIOR TO INSTALLATION OF NEW PRE-COMPRESSED JOINT SEAL AS DIRECTED BY THE ENGINEER.



PRE-COMPRESSED SEAL AT PARAPET

W-21-047

DATE: 1/10/2024

SCALE: NTS

PROJECT NO.: 612097

SHEET 42 OF 54

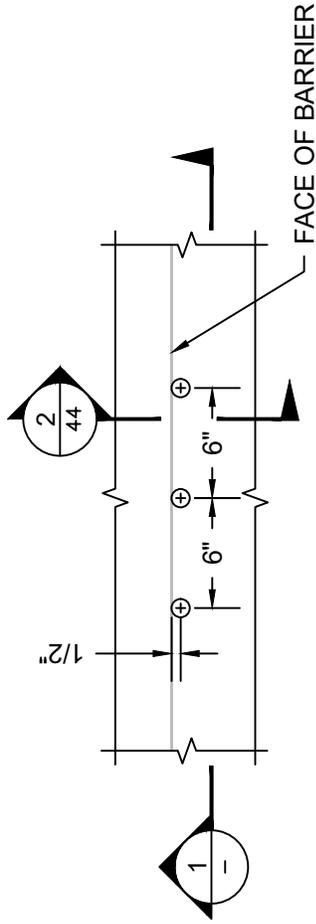

PLAN VIEW

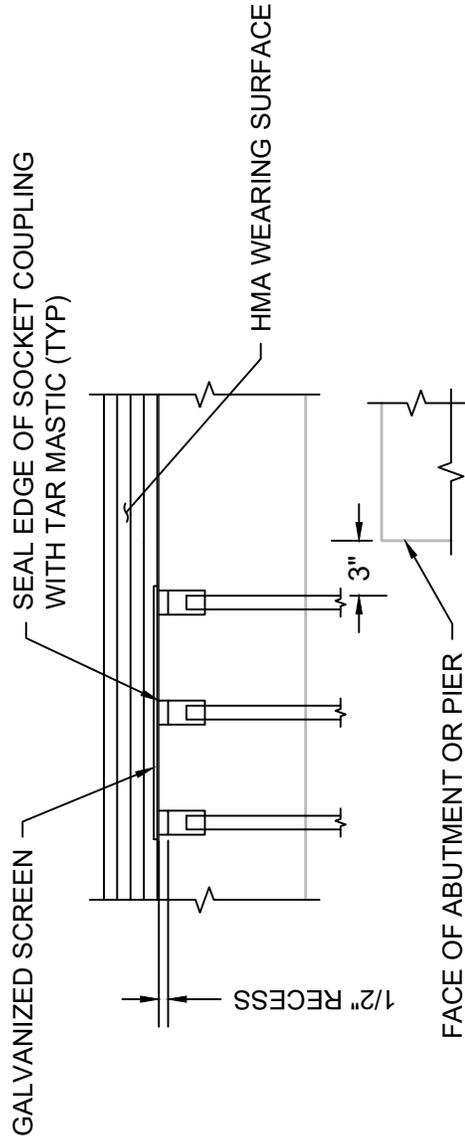

SECTION 1



BRIDGE DECK BLEEDER DETAIL (ITEM 106.15)

W-21-047

DATE: 1/10/2024

SCALE: NTS

PROJECT NO.: 612097

SHEET 43 OF 54

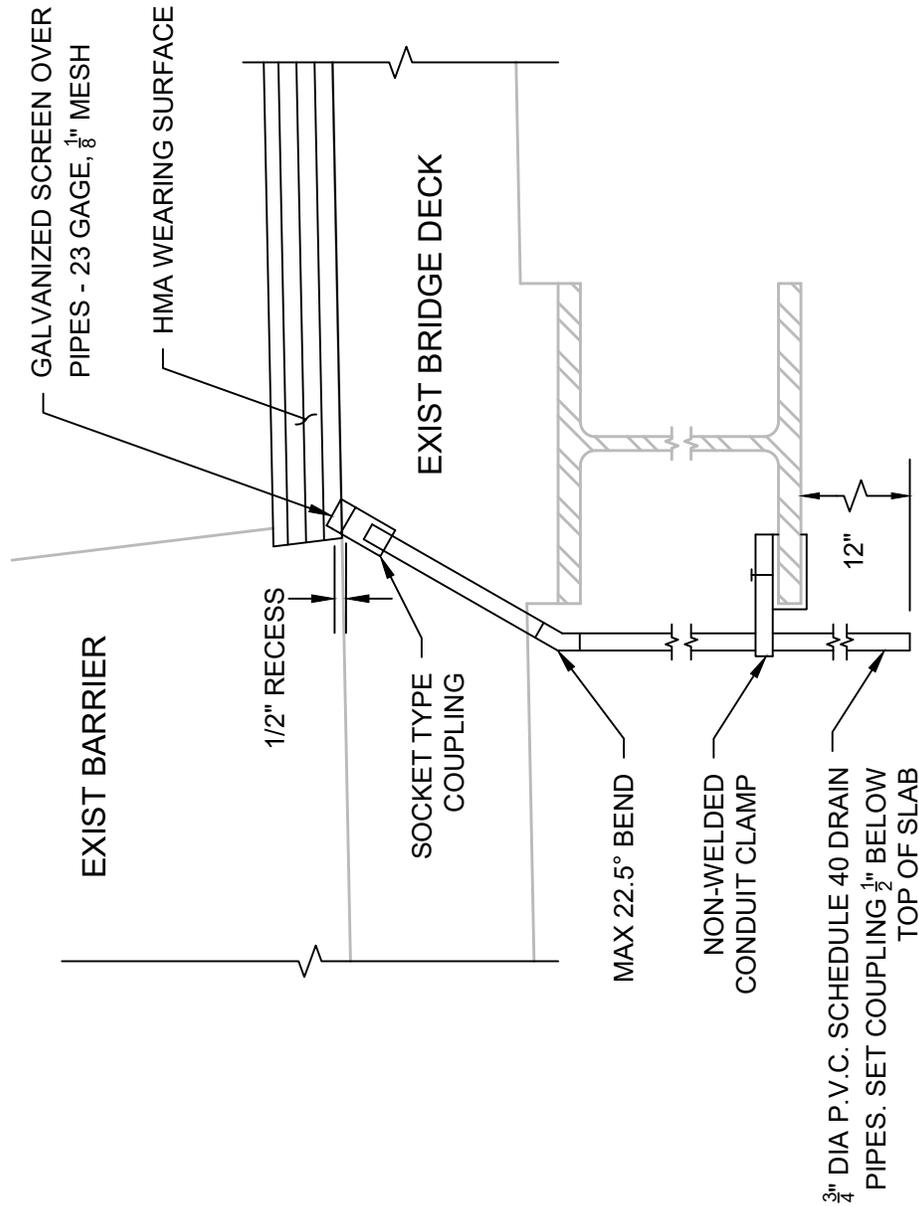

SECTION 2



BRIDGE DECK BLEEDER DETAIL (ITEM 106.15)

W-21-047

DATE: 1/10/2024

SCALE: NTS

PROJECT NO.: 612097

SHEET 44 OF 54

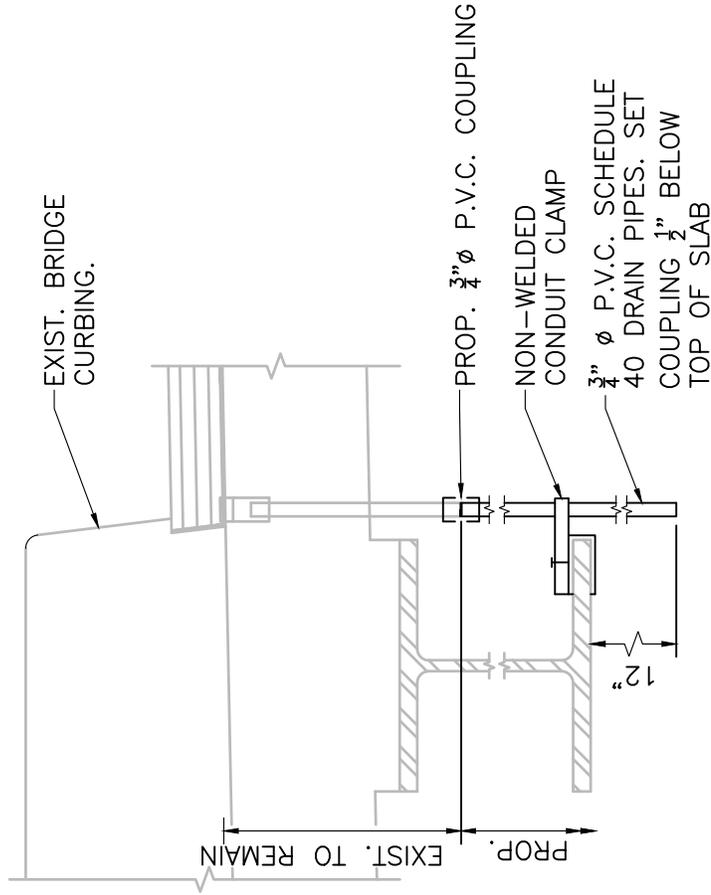

PVC DRAIN PIPE EXTENSIONS

SCALE: NTS



BRIDGE DECK BLEEDER EXTENSION (ITEM 106.151)

W-21-047

DATE: 1/10/2024

SCALE: NTS

PROJECT NO.: 612097

SHEET 45 OF 54

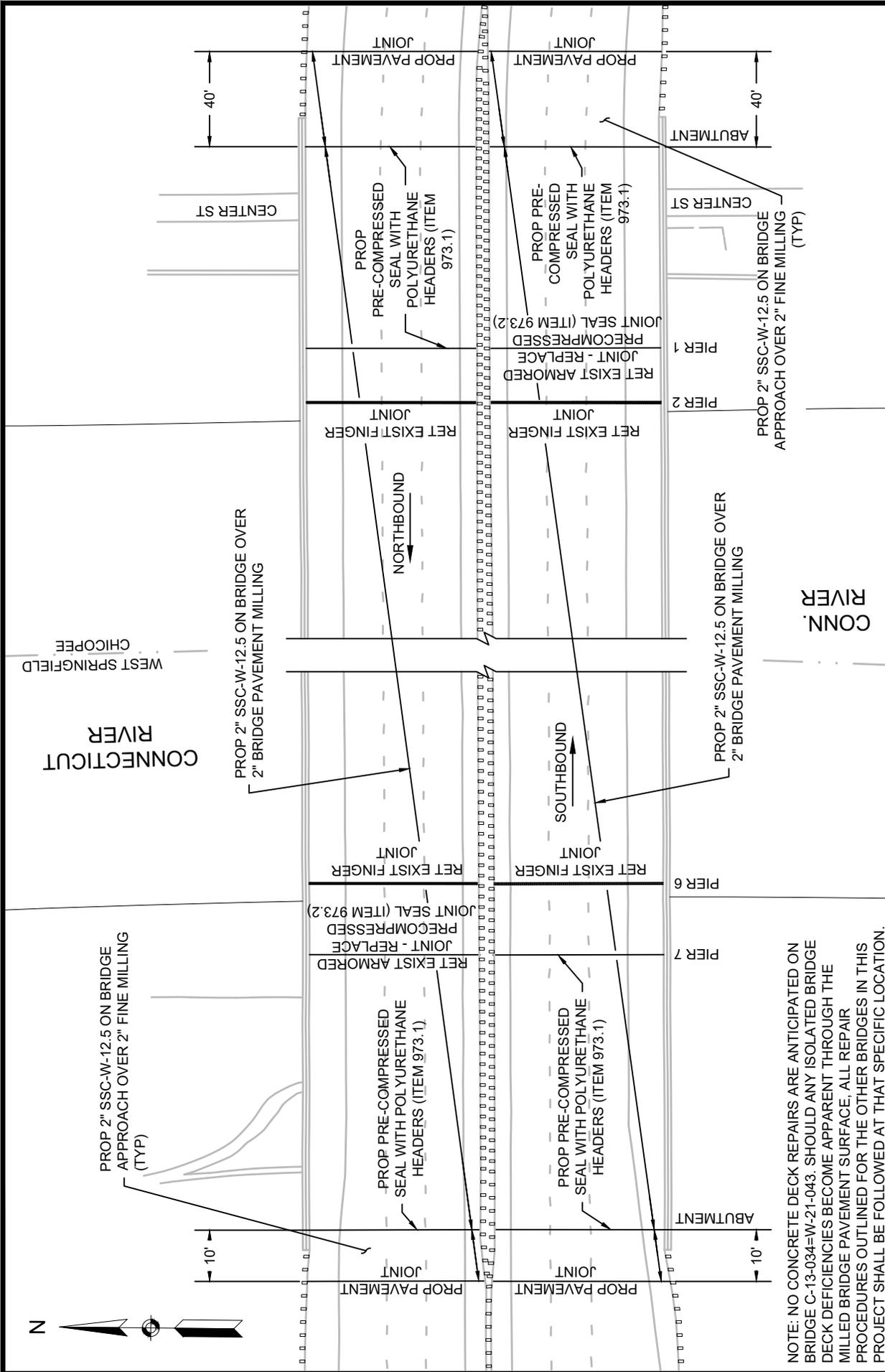

NOTE: NO CONCRETE DECK REPAIRS ARE ANTICIPATED ON BRIDGE C-13-034=W-21-043. SHOULD ANY ISOLATED BRIDGE DECK DEFICIENCIES BECOME APPARENT THROUGH THE MILLED BRIDGE PAVEMENT SURFACE, ALL REPAIR PROCEDURES OUTLINED FOR THE OTHER BRIDGES IN THIS PROJECT SHALL BE FOLLOWED AT THAT SPECIFIC LOCATION.

DATE:	5/17/2024
SCALE:	NTS
PROJECT NO.:	612097
SHEET	46 OF 54

BRIDGE DECK PLAN

C-13-034 = W-21-043



PROPOSED LOCATIONS:
 C-13-034=W-21-043 - PIER 1 SB
 C-13-034=W-21-043 - PIER 7 NB

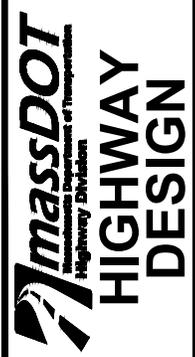
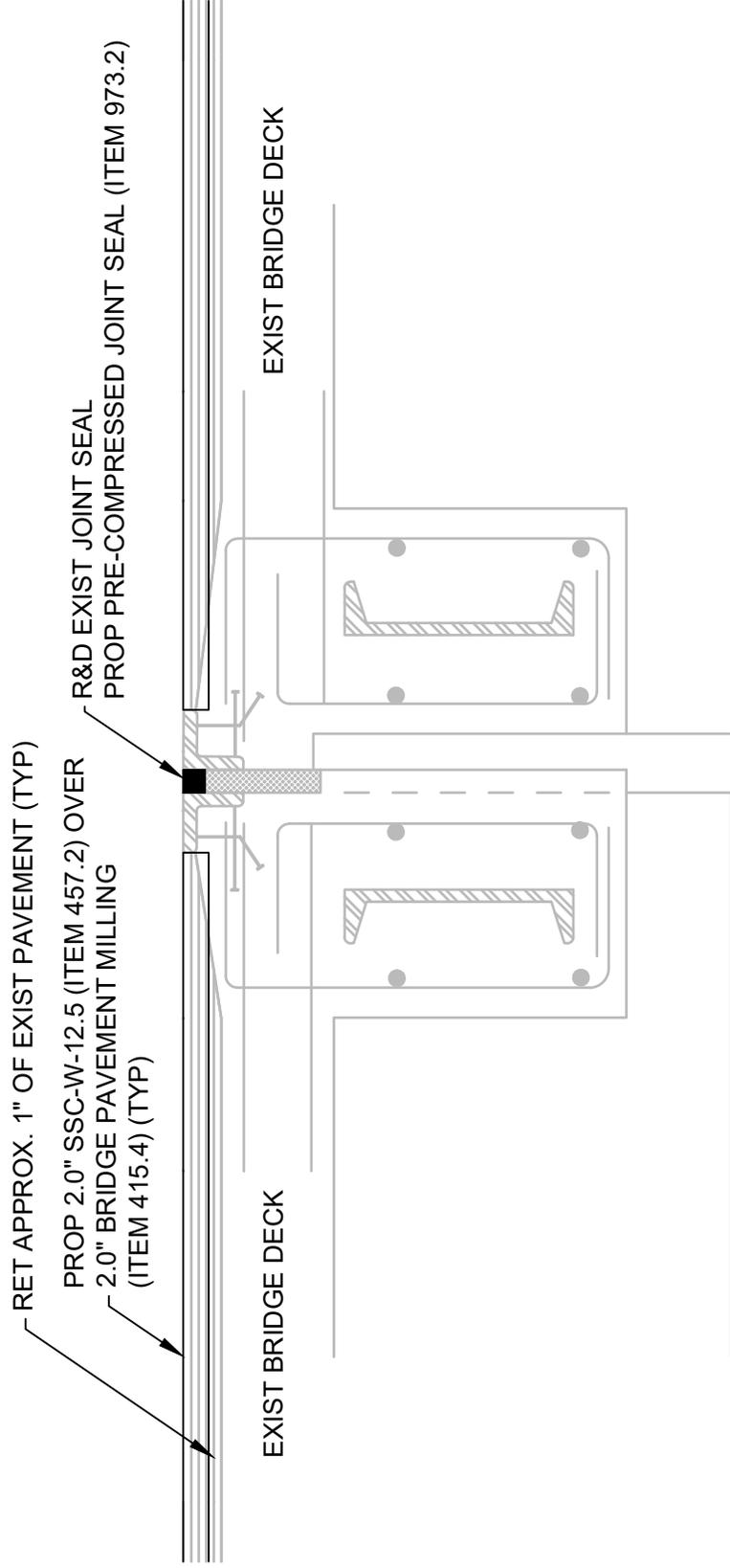

PROPOSED PRECOMPRESSED SEAL REPLACEMENT
 (C-13-034=W-21-043)

DATE:	11/26/24
SCALE:	NTS
PROJECT NO.:	612097
SHEET 47 OF 54	

PROPOSED LOCATIONS:
 C-13-034=W-21-043 - PIER 1 NB
 C-13-034=W-21-043 - PIER 7 SB

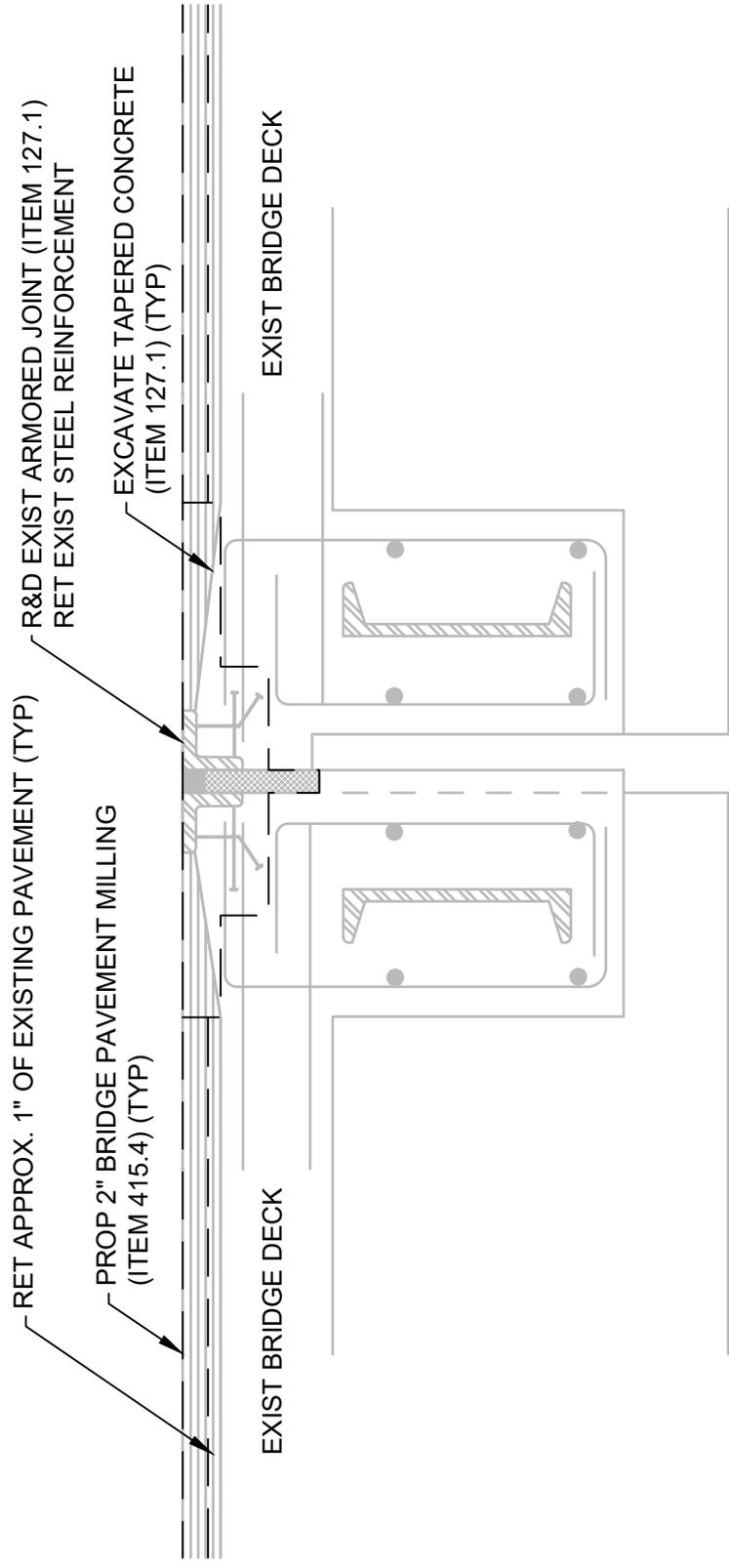

**PROPOSED LIMITS OF ARMORED JOINT EXCAVATION
 AT PIER (C-13-034=W-21-043)**

DATE:	1/10/2024
SCALE:	NTS
PROJECT NO.:	612097
SHEET 48 OF 54	

PROPOSED LOCATIONS:

- C-13-034=W-21-043 - PIER 1 NB
- C-13-034=W-21-043 - PIER 7 SB

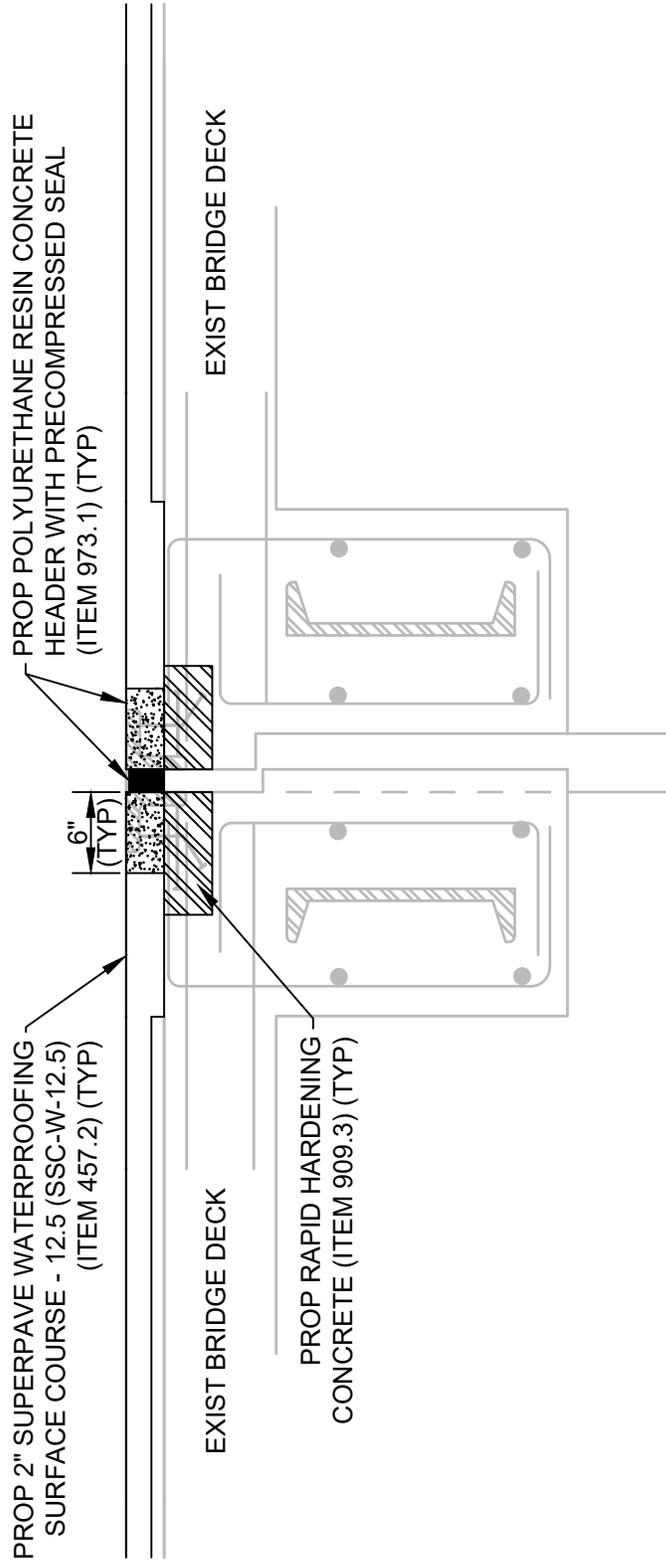

PROP POLYURETHANE RESIN JOINT AT PIER
(C-13-034 = W-21-043)

DATE:	1/10/2024
SCALE:	NTS
PROJECT NO.:	612097
SHEET 49 OF 54	

PROPOSED LOCATIONS:

- C-13-034=W-21-043 - EAST ABUTMENT NB
- C-13-034=W-21-043 - EAST ABUTMENT SB
- C-13-034=W-21-043 - WEST ABUTMENT NB
- C-13-034=W-21-043 - WEST ABUTMENT SB

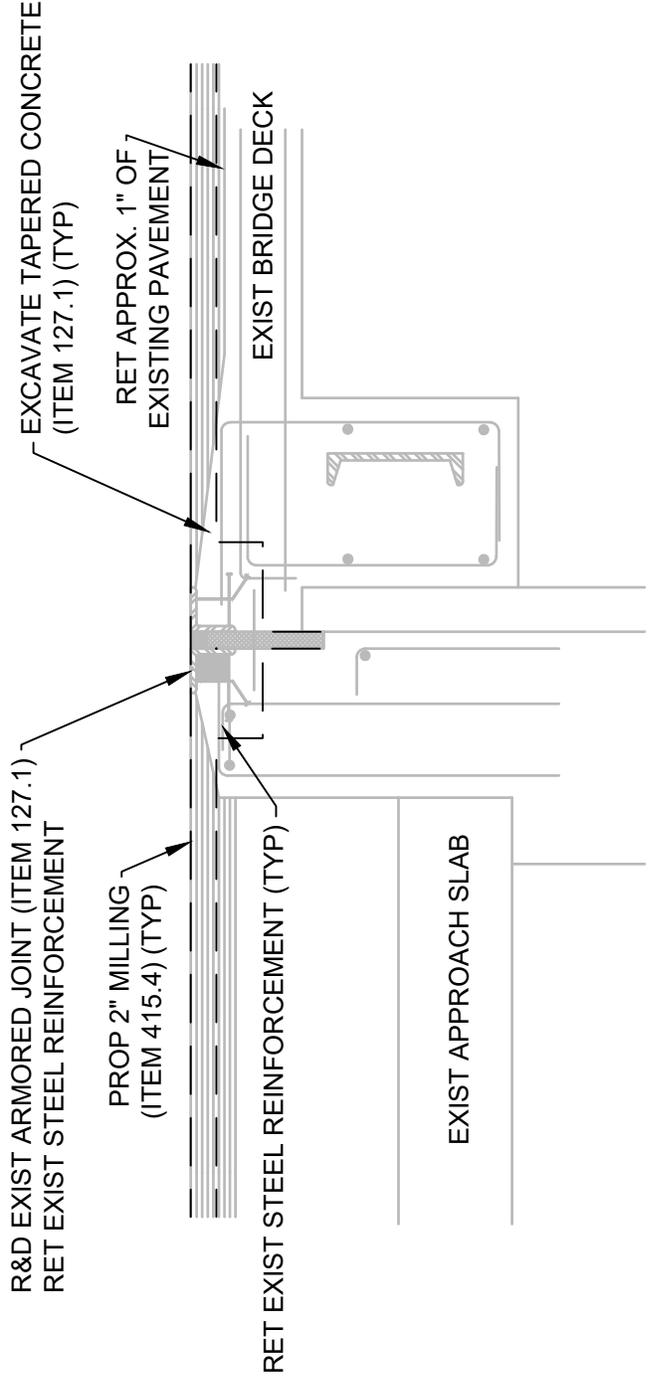

**PROPOSED LIMITS OF ARMORED JOINT EXCAVATION AT
ABUTMENT
(C-13-034=W-21-043)**

DATE:	1/10/2024
SCALE:	NTS
PROJECT NO.:	612097
SHEET	50 OF 54

PROPOSED LOCATIONS:

- C-13-034=W-21-043 - EAST ABUTMENT NB
- C-13-034=W-21-043 - EAST ABUTMENT SB
- C-13-034=W-21-043 - WEST ABUTMENT NB
- C-13-034=W-21-043 - WEST ABUTMENT SB

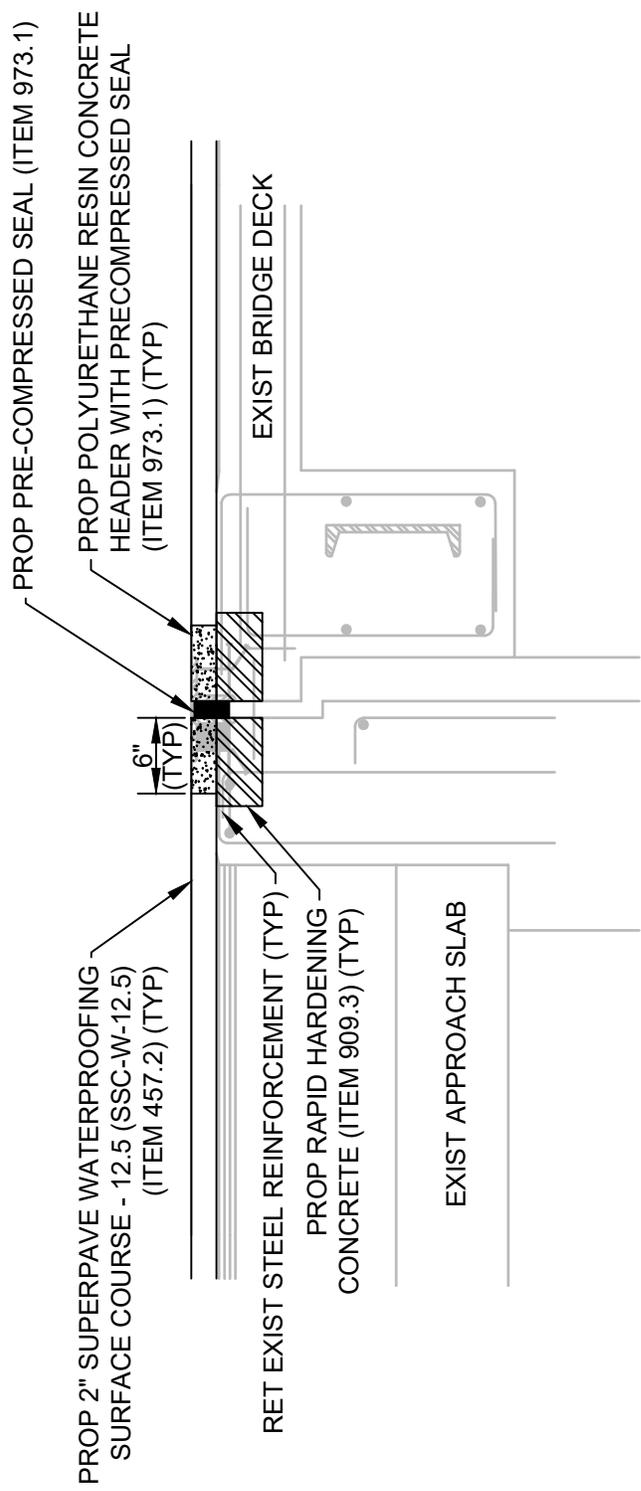

PROP POLYURETHANE RESIN JOINT AT
 ABUTMENT (C-13-034=W-21-043)

DATE:	1/10/2024
SCALE:	NTS
PROJECT NO.:	612097
SHEET 51 OF 54	

PROPOSED LOCATIONS:

- C-13-034=W-21-043 - WEST ABUTMENT NB & SB
- C-13-034=W-21-043 - PIER 7 SB
- C-13-034=W-21-043 - PIER 1 NB
- C-13-034=W-21-043 - EAST ABUTMENT NB & SB

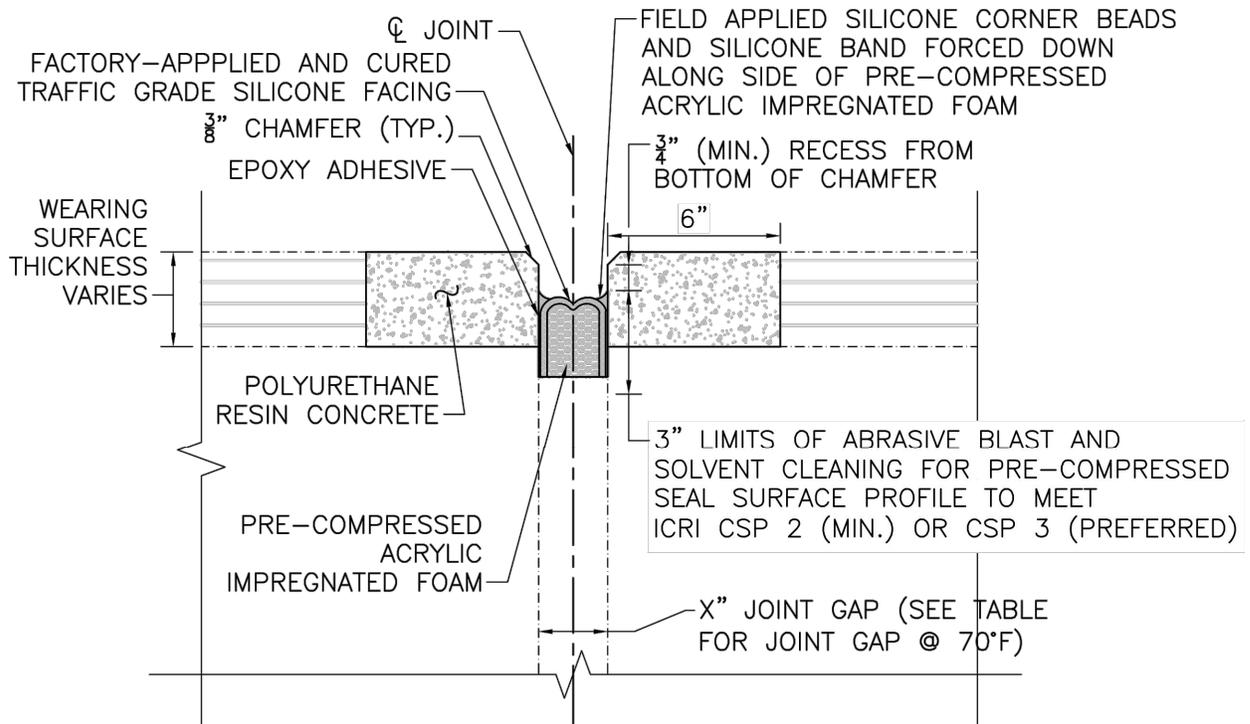

BRIDGE NO.	TRIBUTARY THERMAL EXPANSION/CONTRACTION LENGTH	JOINT GAP (X) @ 70°F	NOMINAL JOINT SEAL WIDTH
C-13-034 (EAST ABUT.)	99'	1.5"	2"
C-13-034 (PIER 1)	0'	1"	1.5"
C-13-034 (PIER 7)	0'	1"	1.5"
C-13-034 (WEST ABUT.)	115.5'	1.5"	2"



PRE-COMPRESSED SEAL SECTION
(C-13-034=W-21-043)

DATE: 4/15/24
SCALE: NTS
PROJECT NO.: 612097
SHEET 52 OF 54

PROPOSED LOCATIONS:

- C-13-034=W-21-043 - WEST ABUTMENT NB & SB
- C-13-034=W-21-043 - PIER 7 NB & SB
- C-13-034=W-21-043 - PIER 1 NB & SB
- C-13-034=W-21-043 - EAST ABUTMENT NB & SB

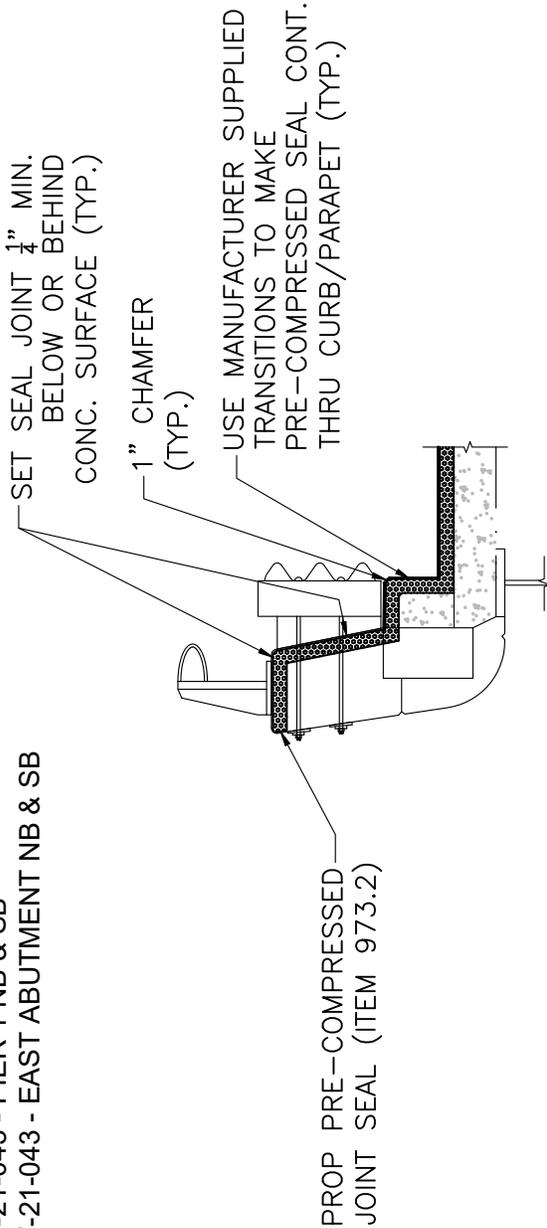

PRE-COMPRESSED SEAL AT PARAPET

NOT TO SCALE

NOTES:

- 1). SEE PRE-COMPRESSED JOINT SEAL DETAIL.
- 2). CLEAN JOINT PRIOR TO INSTALLATION OF NEW PRE-COMPRESSED JOINT SEAL.
- 3). REPAIR PARAPET PRIOR TO INSTALLATION OF NEW PRE-COMPRESSED JOINT SEAL AS DIRECTED BY THE ENGINEER.



PRE-COMPRESSED SEAL AT PARAPET

(C-13-034=W-21-043)

DATE: 1/10/2024

SCALE: NTS

PROJECT NO.: 612097

SHEET 53 OF 54

PRE-COMPRESSED SEAL JOINT NOTES

1. THE INSTALLATION AND SPLICING OF THE PRE-COMPRESSED SEAL SHALL FOLLOW THE MANUFACTURER'S INSTRUCTIONS.
2. THE JOINT SYSTEM INSTALLATION SHALL TAKE PLACE AFTER THE DECK REPAIR MATERIAL ADJACENT TO THE JOINT OPENING HAS SUFFICIENTLY CURED.
3. THE JOINT OPENING SHALL BE FREE OF ALL CONTAMINANTS SUCH AS GREASE, DUST, AND DIRT. PRIOR TO JOINT SYSTEM INSTALLATION, THE JOINT WALLS SHALL BE BLOWN CLEAN WITH OIL-FREE COMPRESSED AIR AND WIPED CLEAN WITH A CLEAN WET CLOTH TO THE BOTTOM OF THE PRE-COMPRESSED SEAL MATERIAL PLUS 1" TO REMOVE ANY DUST REMAINING. THE SUBSTRATE PREP SHALL FOLLOW THE ICRI CONCRETE SURFACE PROFILE STANDARDS TO ACHIEVE A SURFACE PROFILE OF CSP 2 (MIN.) OR 3 (PREFERRED) IN ORDER TO ACCEPT THE JOINT SYSTEM.
4. THE PRE-COMPRESSED SEAL JOINT SYSTEM SHALL BE CONTINUOUS THROUGH CURBS, MEDIANS, AND PARAPETS AS APPROPRIATE TO THE CONDITIONS AT HAND. CONTINUITY OF SEAL SHALL BE ACHIEVED THROUGH THE USE OF FACTORY-FABRICATED UNIVERSAL OR CUSTOM TRANSITIONS SUPPLIED BY THE PRE-COMPRESSED JOINT SEAL MANUFACTURER. THE FIELD SPLICE OF THE PRE-COMPRESSED SEAL SHALL BE DONE IN ACCORDANCE WITH THE MANUFACTURER'S RECOMMENDATIONS.
5. THE HEADER CONCRETE SHALL CONSIST OF POLYURETHANE RESIN AND AGGREGATE THAT CONSISTS OF SAND AND CHOPPED FIBERGLASS. THE RATIO OF AGGREGATE TO RESIN BY WEIGHT SHALL NOT EXCEED 2. SEE SPECIAL PROVISIONS.
6. THE HEADER CONCRETE SHALL BE SUFFICIENTLY CURED SO THAT VEHICULAR TRAFFIC MAY BE APPLIED IN NO MORE THAN 2 HOURS AFTER MIXING AND PLACEMENT.



**PRE-COMPRESSED SEAL JOINT
NOTES**
(C-13-034=W-21-043)

DATE: 4/15/24
SCALE: NTS
PROJECT NO.: 612097
SHEET 54 OF 54

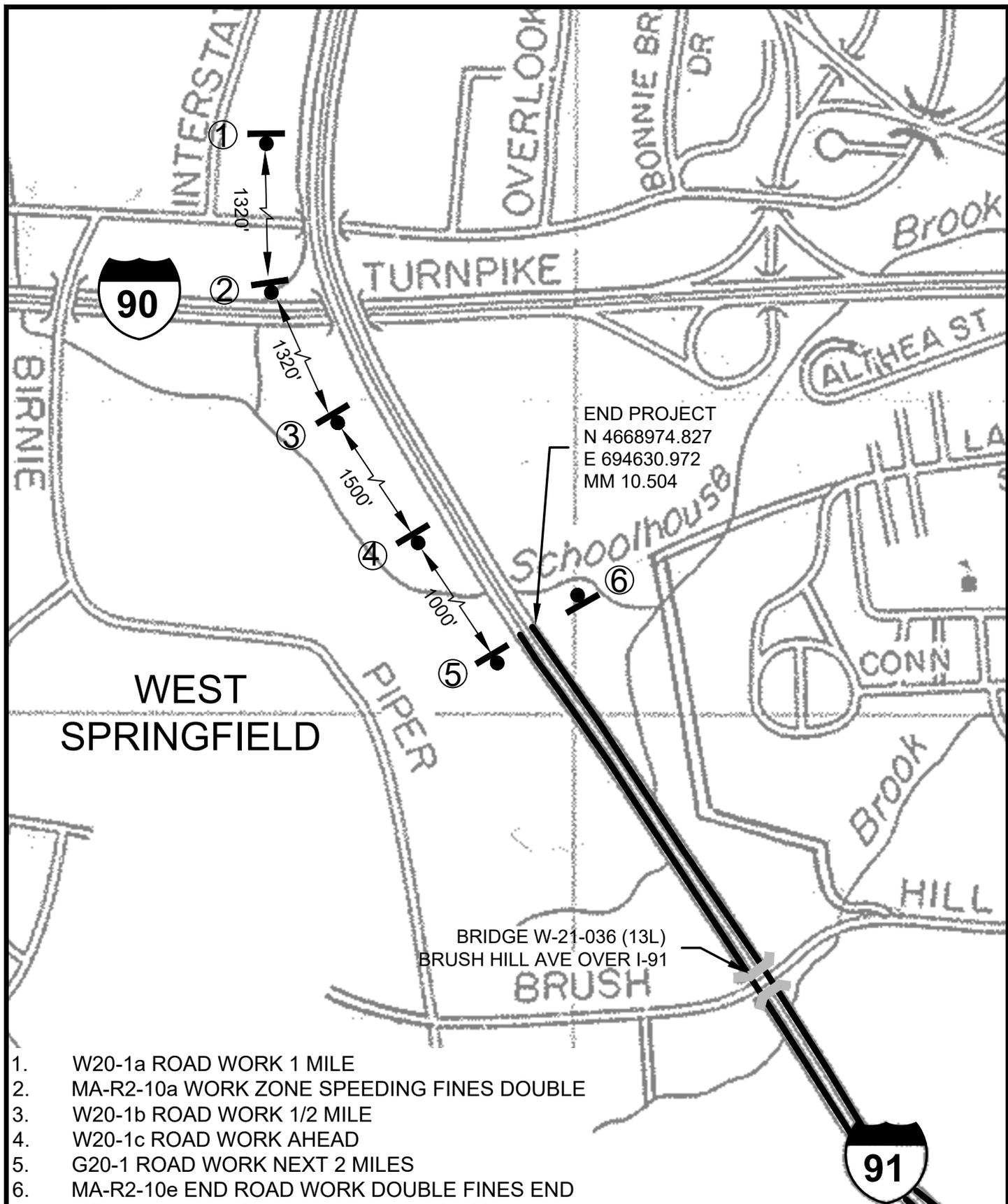

1. W20-1a ROAD WORK 1 MILE
2. MA-R2-10a WORK ZONE SPEEDING FINES DOUBLE
3. W20-1b ROAD WORK 1/2 MILE
4. W20-1c ROAD WORK AHEAD
5. G20-1 ROAD WORK NEXT 2 MILES
6. MA-R2-10e END ROAD WORK DOUBLE FINES END

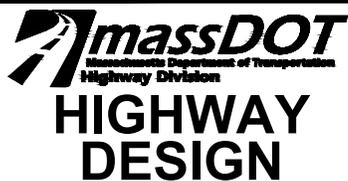

TTCP
LONG TERM ADVANCE WARNING
SIGN PLACEMENT

DATE:	12/19/2023
SCALE:	NTS
PROJECT NO.:	612097
SHEET 1 OF 22	

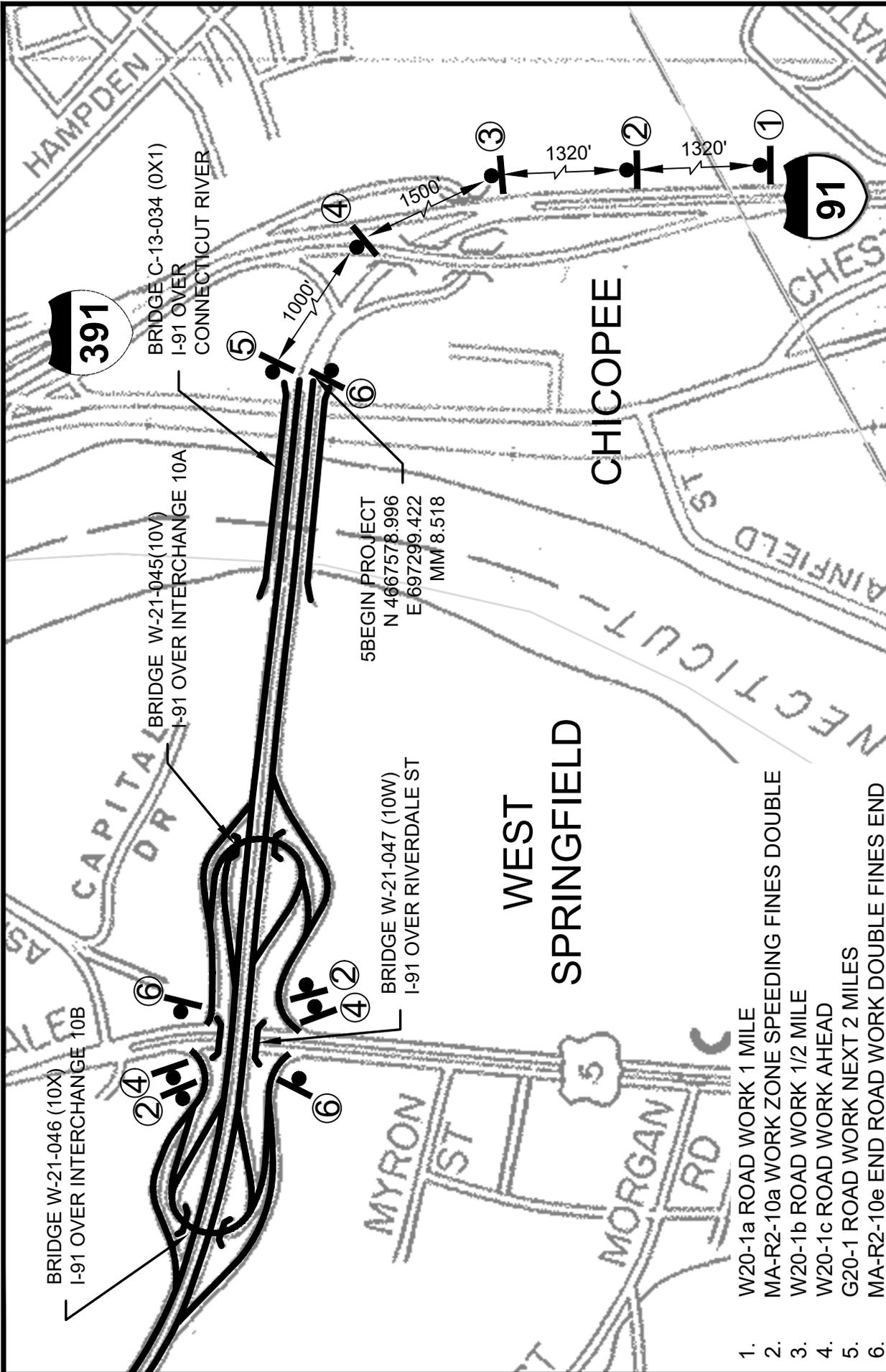

1. W20-1a ROAD WORK 1 MILE
2. MA-R2-10a WORK ZONE SPEEDING FINES DOUBLE
3. W20-1b ROAD WORK 1/2 MILE
4. W20-1c ROAD WORK AHEAD
5. G20-1 ROAD WORK NEXT 2 MILES
6. MA-R2-10e END ROAD WORK DOUBLE FINES END



TTCP
LONG TERM ADVANCE WARNING SIGN PLACEMENT

DATE:	12/20/2023
SCALE:	NTS
PROJECT NO.:	612097
SHEET 2 OF 22	

NOTES:

1. ALL TEMPORARY TRAFFIC CONTROL WORK SHALL CONFORM TO THE LATEST EDITION OF THE "MANUAL ON UNIFORM TRAFFIC CONTROL DEVICES" (MUTCD) AND ALL REVISIONS, UNLESS SUPERCEDED BY THESE PLANS.
2. ALL SIGN LEGENDS, BORDERS, AND MOUNTING SHALL BE IN ACCORDANCE WITH THE MUTCD.
3. TEMPORARY CONSTRUCTION SIGNING AND ALL OTHER TRAFFIC CONTROL DEVICES SHALL BE IN PLACE PRIOR TO THE START OF ANY WORK.
4. TEMPORARY CONSTRUCTION SIGNING, BARRICADES, AND ALL OTHER NECESSARY WORK ZONE TRAFFIC CONTROL DEVICES SHALL BE REMOVED FROM THE HIGHWAY OR COVERED WHEN THEY ARE NOT REQUIRED FOR CONTROL OF TRAFFIC.
5. SIGNS AND SIGN SUPPORTS LOCATED ON OR NEAR THE TRAVELED WAY, CHANNELIZING DEVICES, BARRIERS, AND CRASH ATTENUATORS MUST PASS THE CRITERIA SET FORTH IN NCHRP REPORT 350, "RECOMMENDED PROCEDURES FOR THE SAFETY PERFORMANCE EVALUATION OF HIGHWAY FEATURES" AND/OR "MANUAL FOR ASSESSING SAFETY HARDWARE" (MASH).
6. CONTRACTORS SHALL NOTIFY EACH ABUTTER AT LEAST 24 HOURS IN ADVANCE OF THE START OF ANY WORK THAT WILL REQUIRE THE TEMPORARY CLOSURE OF ACCESS, SUCH AS CONDUIT INSTALLATION, EXISTING PAVEMENT EXCAVATION, TEMPORARY DRIVEWAY PAVEMENT PLACEMENT, AND SIMILAR OPERATIONS.
7. THE FIRST FIVE PLASTIC DRUMS OF A TAPER SHALL BE MOUNTED WITH TYPE A LIGHTS.
8. THE ADVISORY SPEED LIMIT, IF REQUIRED, SHALL BE DETERMINED BY THE ENGINEER.
9. DISTANCES ARE A GUIDE AND MAY BE ADJUSTED IN THE FIELD BY THE ENGINEER.
10. MAXIMUM SPACING OF TRAFFIC DEVICES IN A TAPER (DRUMS OR CONES) IS EQUAL IN FEET TO THE SPEED LIMIT IN MPH.
11. MINIMUM LANE WIDTH IS TO BE 11-FEET UNLESS OTHERWISE SHOWN. MINIMUM LANE WIDTH TO BE MEASURED FROM THE EDGE OF DRUMS OR MEDIAN BARRIER.
12. ALL SIGNS SHALL BE MOUNTED ON THEIR OWN STANDARD SIGN SUPPORTS.

LEGEND:

-  REFLECTORIZED PLASTIC DRUM OR 36" CONE
-  WORK ZONE
-  WORK VEHICLE
-  P/F POLICE/FLAGGER DETAIL
-  DIRECTION OF TRAFFIC
-  TRUCK MOUNTED ATTENUATOR
-  TYPE III BARRICADE
-  IMPACT ATTENUATOR
-  TRAFFIC OR PEDESTRIAN SIGNAL
-  CHANGEABLE MESSAGE SIGN
-  MEDIAN BARRIER
-  SIGN
-  ARROW BOARD
-  MEDIAN BARRIER WITH WARNING LIGHTS

THE IDEAL CAPACITY OF A MAJOR HIGHWAY IS GENERALLY CONSIDERED TO BE 1900 PASSENGER CARS PER HOUR PER LANE (PCPHPL). IN WORK ZONES ON A MULTI-LANE DIVIDED HIGHWAY, THE FOLLOWING VOLUME GUIDELINES HAVE BEEN SUGGESTED:

MEASURED AVERAGE WORK ZONE CAPACITIES

NUMBER OF LANES		NUMBER OF STUDIES	AVERAGE CAPACITY	
NORMAL (EXISTING)	OPEN (TO TRAFFIC)		VPH	VPHPL
3	1	7	1,170	1,170
2	1	8	1,340	1,340
5	2	8	2,740	1,370
4	2	4	2,960	1,480
3	2	9	2,980	1,490
4	3	4	4,560	1,520

Source: Dudek, C., Notes on Work Zone Capacity and Level of Service. Texas Transportation Institute, Texas A&M University, College Station, Texas (1984)

BY OBTAINING HOURLY TRAFFIC COUNTS FOR A PARTICULAR ROADWAY (WITH A MINIMUM OF A 48-HOUR AUTOMATIC TRAFFIC RECORDER (ATR) COUNT), THIS WILL HELP TO DETERMINE AT WHAT TIMES OF THE DAY OR NIGHT A CERTAIN NUMBER OF LANES MAY BE CLOSED.



TTCP
GENERAL GUIDELINES

DATE:	12/16/2023
SCALE:	NTS
PROJECT NO.:	612097
SHEET	3 OF 22

ROAD TYPE	DISTANCE			
	A	B	C	D
URBAN (30 MPH OR LESS)	100 FEET	100 FEET	100 FEET	100 FEET
URBAN (35 MPH OR GREATER)	350 FEET	350 FEET	350 FEET	350 FEET
RURAL	500 FEET	500 FEET	500 FEET	500 FEET
EXPRESSWAY/FREEWAY	1,000 FEET	1,500 FEET	2,640 FEET	500 FEET

* ROAD TYPE TO BE DETERMINED BY MASSDOT OFFICE OF TRANSPORTATION PLANNING.

** DISTANCES ARE SHOWN IN FEET (METERS). THE COLUMN HEADINGS A, B, AND C ARE THE DIMENSIONS SHOWN IN THE DETAIL/ TYPICAL SETUP FIGURES. THE A DIMENSION IS THE DISTANCE FROM THE TRANSITION OR POINT OF RESTRICTION TO THE FIRST SIGN. THE B DIMENSION IS THE DISTANCE BETWEEN THE FIRST AND SECOND SIGNS. THE C DIMENSION IS THE DISTANCE BETWEEN THE SECOND AND THIRD SIGNS. (THE "THIRD" SIGN IS THE FIRST ONE TYPICALLY ENCOUNTERED BY A DRIVER APPROACHING A TEMPORARY TRAFFIC CONTROL (TTC) ZONE.)

THE "THIRD" SIGN ABOVE IS TYPICALLY REFERRED TO AS AN "ADVANCE WARNING" SIGN ON THE TTCP SETUPS. THESE ADVANCE WARNING SIGNS ARE LOCATED PRIOR TO THE PROJECT LIMITS ON ALL APPROACHES (i.e. THE W20-1 SERIES (ROAD WORK XX FT) SIGNS), AND USUALLY REMAIN FOR THE DURATION OF THE PROJECT. ADDITIONAL SIGNS (i.e. "RIGHT LANE CLOSED 1 MILE" AND "LEFT LANE CLOSED 1 MILE") HAVE BEEN SHOWN IN SOME FIGURES AS EXAMPLES OF REINFORCEMENT SIGN PLACEMENT BUT ARE USED IN RARE OCCASIONS.

THE FIRST AND SECOND WARNING SIGNS ABOVE ARE REFERRED TO AS THE OPERATIONAL (DAY-TO-DAY) WORK ZONE SIGNS AND MAY BE MOVED DEPENDING ON WHERE THE SPECIFIC ROADWAY WORK FOR THAT DAY IS LOCATED.

MA-R2-10a SIGNS SHALL BE PLACED BETWEEN THE SECOND AND THIRD SIGNS AS DESCRIBED ABOVE.

MA-R2-10a, MA-R2-10e, AND W20-1 SERIES SIGNS ARE TO BE INCLUDED ON ALL DETAILS/TYPICAL SETUPS.

Based on: Table 6C-1 MUTCD LATEST EDITION

STOPPING SIGHT DISTANCE AS A FUNCTION OF SPEED

SPEED* (mph)	DISTANCE (ft)
20	115
25	155
30	200
35	250
40	305
45	360
50	425
55	495
60	570
65	645
70	730
75	820

*POSTED SPEED, OFF-PEAK 85TH-PERCENTILE SPEED PRIOR TO WORK STARTING, OR THE ANTICIPATED OPERATING SPEED

THESE VALUES MAY BE USED TO DETERMINE THE LENGTH OF LONGITUDINAL BUFFER SPACES.

THE DISTANCES IN THE ABOVE CHART REPRESENT THE MINIMAL VALUES FOR BUFFER SPACING.

Source: Table 6C-2 MUTCD LATEST EDITION



TTCP
NOTES ON WORK ZONE DISTANCES

DATE:	12/16/2023
SCALE:	NTS
PROJECT NO.:	612097
SHEET	4 OF 22

CONVENTIONAL ROADWAY- A STREET OR HIGHWAY OTHER THAN A LOW-VOLUME ROAD, EXPRESSWAY, OR FREEWAY.

EXPRESSWAY- A DIVIDED HIGHWAY WITH PARTIAL CONTROL OF ACCESS.

FREEWAY- A DIVIDED HIGHWAY WITH FULL CONTROL OF ACCESS.

LOW-VOLUME ROAD- A FACILITY LYING OUTSIDE OF BUILT-UP AREAS OF CITIES, TOWNS, AND COMMUNITIES, AND IT SHALL HAVE A TRAFFIC VOLUME OF LESS THAN 400 AADT. IT SHALL NOT BE A FREEWAY, EXPRESSWAY, INTERCHANGE RAMP, FREEWAY SERVICE ROAD OR A ROAD ON A DESIGNATED STATE HIGHWAY SYSTEM.

Source: MUTCD LATEST EDITION

TAPER LENGTH CRITERIA FOR TEMPORARY TRAFFIC CONTROL ZONES

TYPE OF TAPER	TAPER LENGTH (L)*
MERGING TAPER	AT LEAST L
SHIFTING TAPER	AT LEAST 0.5L
SHOULDER TAPER	AT LEAST 0.33L
ONE-LANE, TWO-WAY TRAFFIC TAPER	50 FT MIN. 100 FT MAX.
DOWNSTREAM TAPER	50 FT MIN. 100 FT MAX. PER LANE

Source: Table 6C-3 MUTCD LATEST EDITION

FORMULAS FOR DETERMINING TAPER LENGTHS

SPEED LIMIT (S)	TAPER LENGTH (L) FEET
40 MPH OR LESS	$L = \frac{WS^2}{60}$
45 MPH OR MORE	$L = WS$

WHERE: L = TAPER LENGTH IN FEET

W = WIDTH OF OFFSET IN FEET

S = POSTED SPEED LIMIT, OR OFF-PEAK 85TH-PERCENTILE SPEED PRIOR TO WORK STARTING, OR THE ANTICIPATED OPERATING SPEED IN MPH

Source: Table 6C-4 MUTCD LATEST EDITION



TTCP

NOTES ON WORK ZONE DISTANCES

DATE:	12/16/2023
SCALE:	NTS
PROJECT NO.:	612097
SHEET	5 OF 22

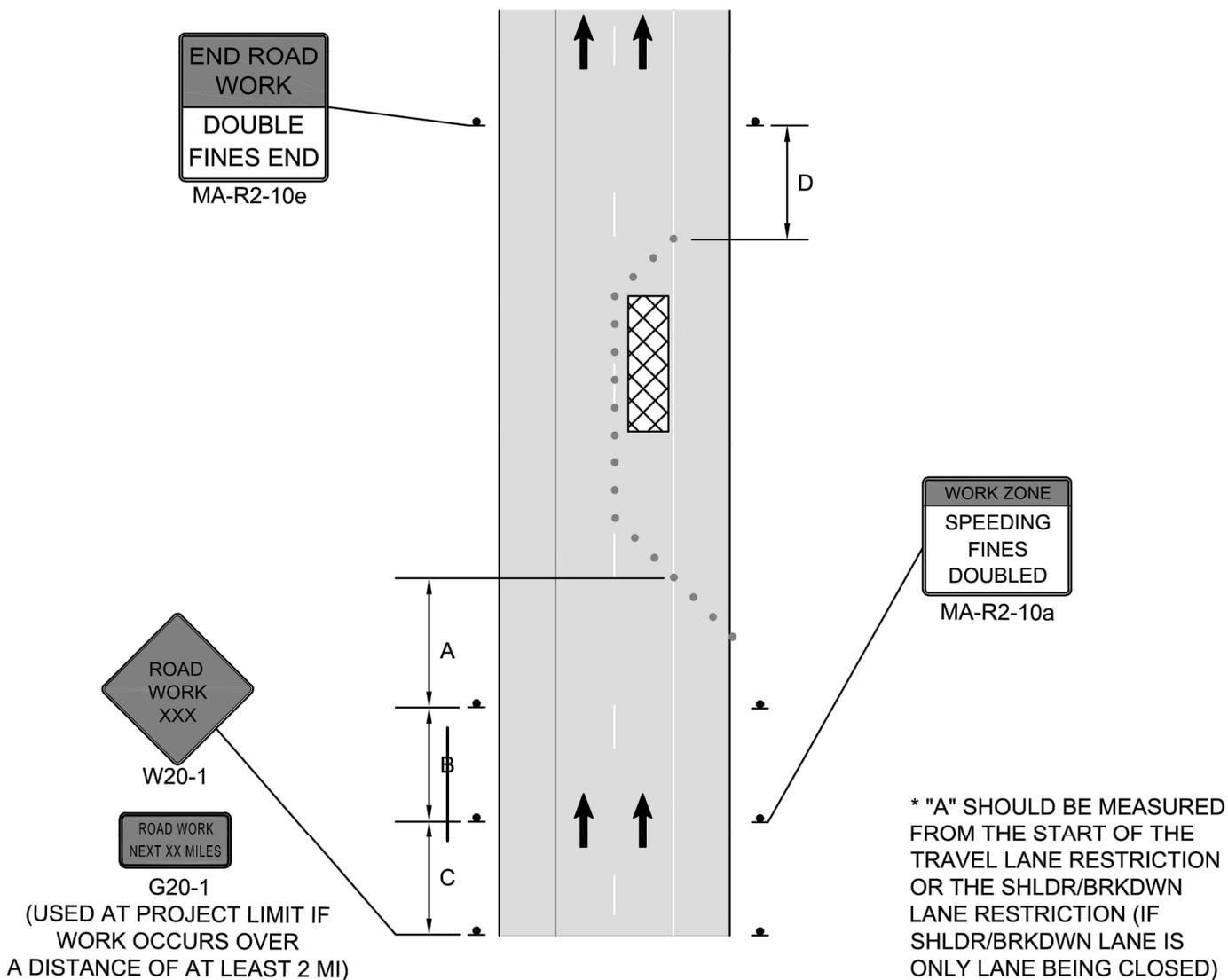

* "A" SHOULD BE MEASURED FROM THE START OF THE TRAVEL LANE RESTRICTION OR THE SHLDR/BRKDOWN LANE RESTRICTION (IF SHLDR/BRKDOWN LANE IS ONLY LANE BEING CLOSED)



TTCP

COMPONENT PARTS OF A TEMPORARY TRAFFIC CONTROL ZONE

DATE:	12/16/2023
SCALE:	NTS
PROJECT NO.:	612097
SHEET	6 OF 22

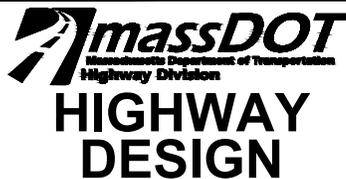
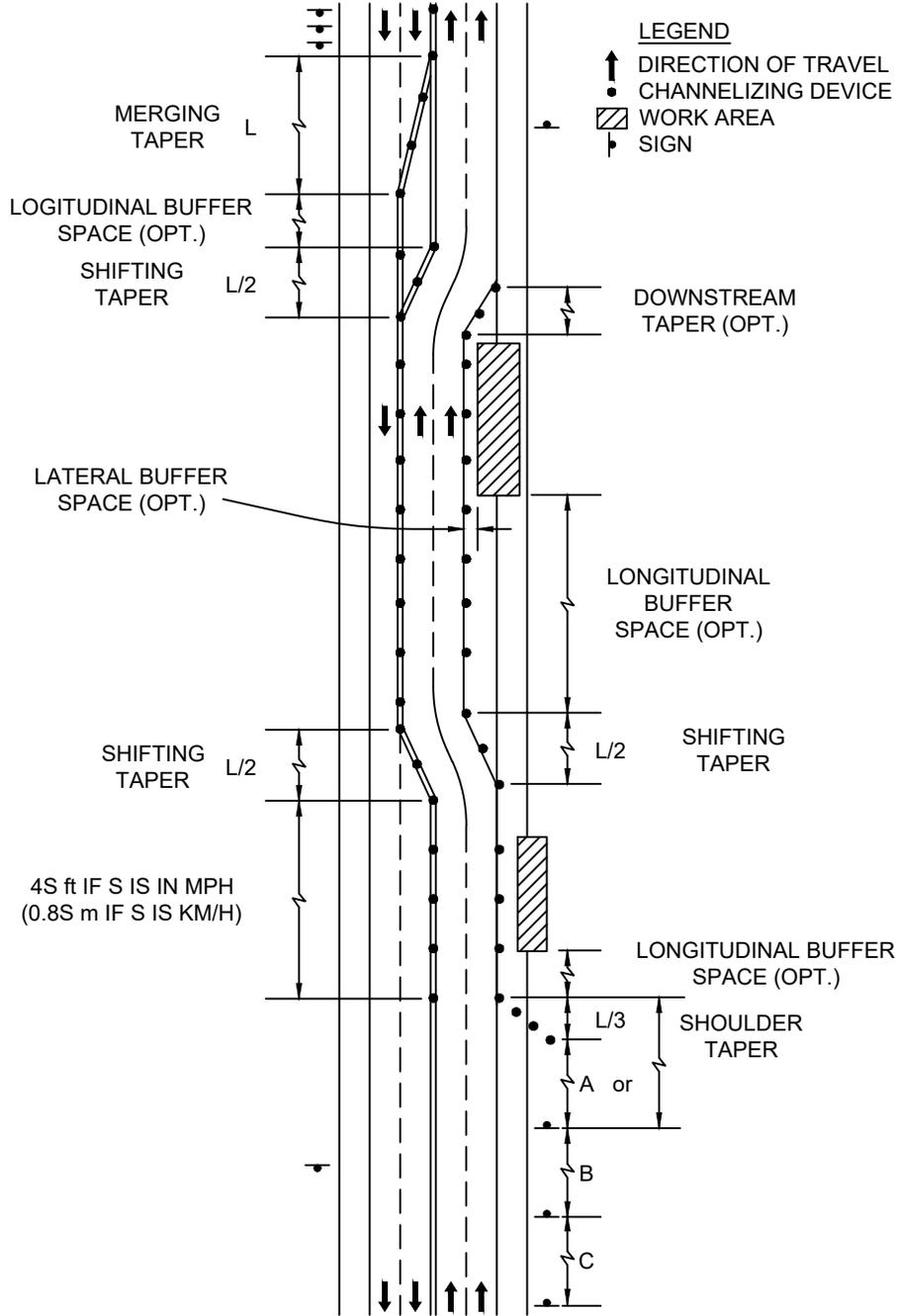

TTCP
TYPES OF TAPERS AND BUFFER SPACES

DATE:	12/16/2023
SCALE:	NTS
PROJECT NO.:	612097
SHEET	7 OF 22

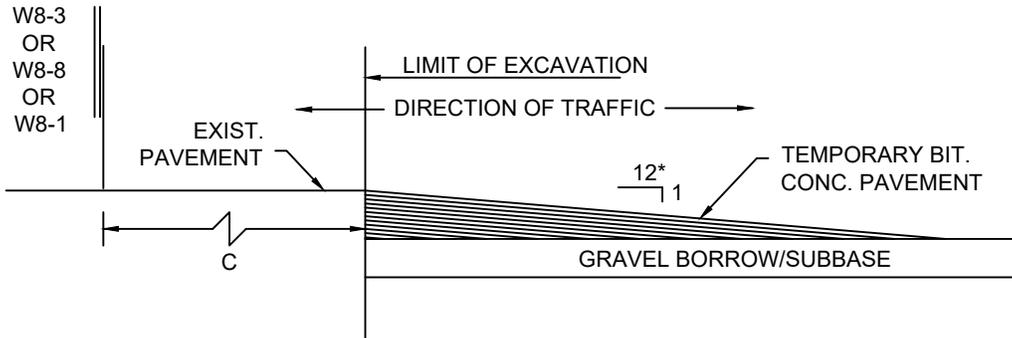
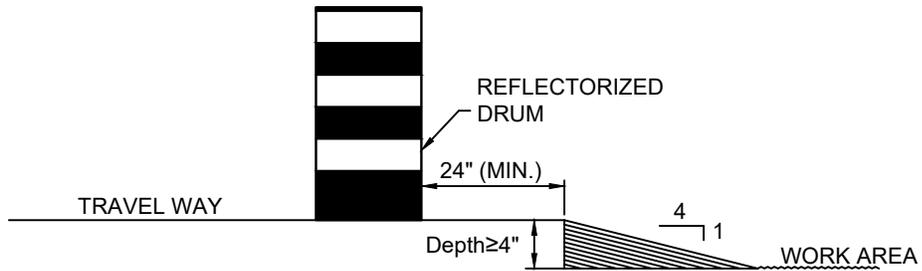

* - INCREASE SLOPE RATIO FOR HIGHER SPEEDS

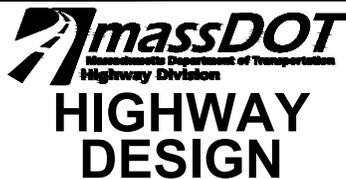

TTCP
LATERAL AND LONGITUDINAL DROP-OFF DETAILS

DATE:	12/16/2023
SCALE:	NTS
PROJECT NO.:	612097
SHEET	8 OF 22

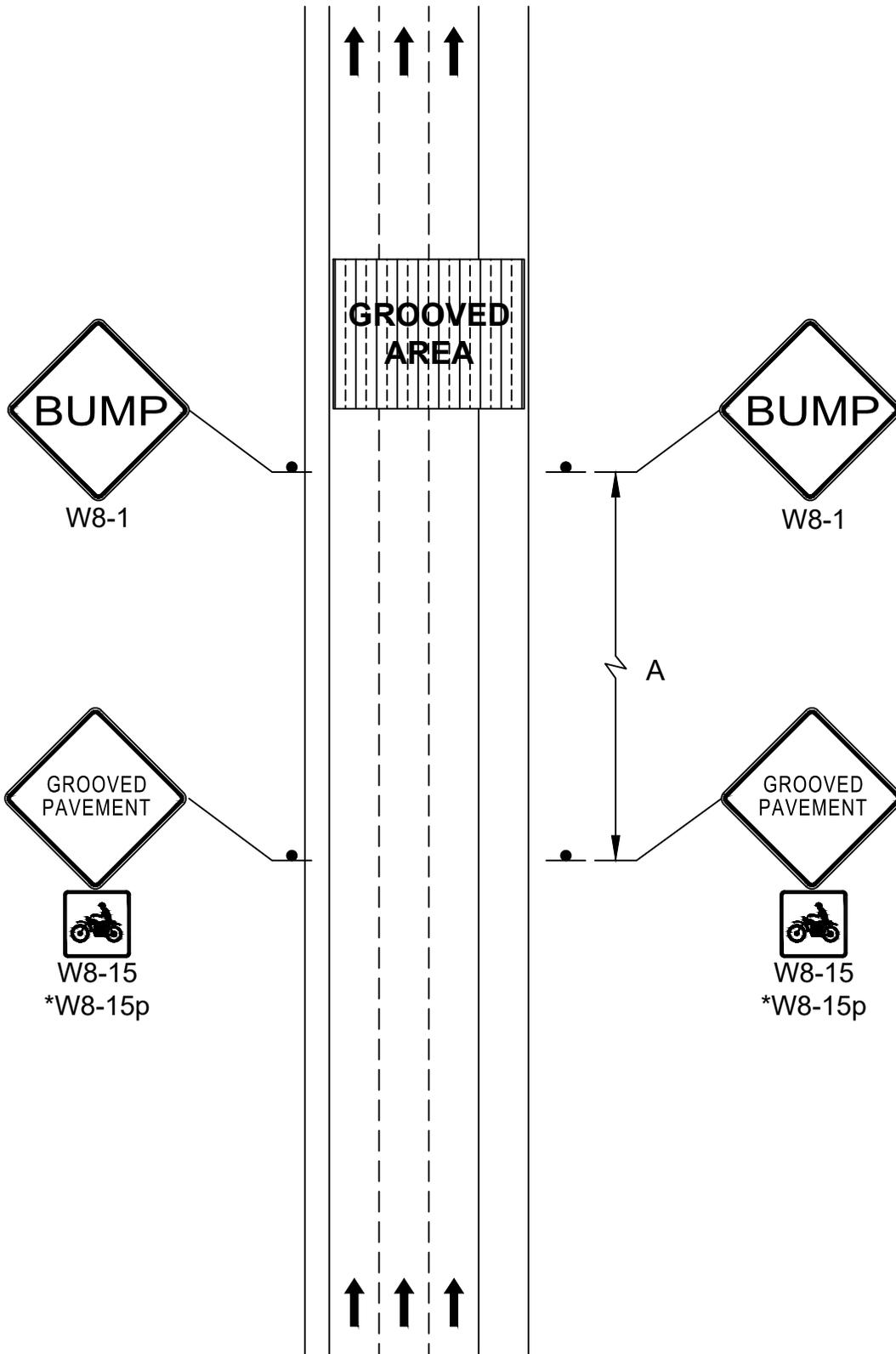

*FOR SYMBOL SEE MUTCD LATEST EDITION FIGURE 6F-4



TTCP

DIVIDED HIGHWAY SCARIFIED PAVEMENT / STEEL PLATE

DATE:	12/16/2023
SCALE:	NTS
PROJECT NO.:	612097
SHEET	9 OF 22

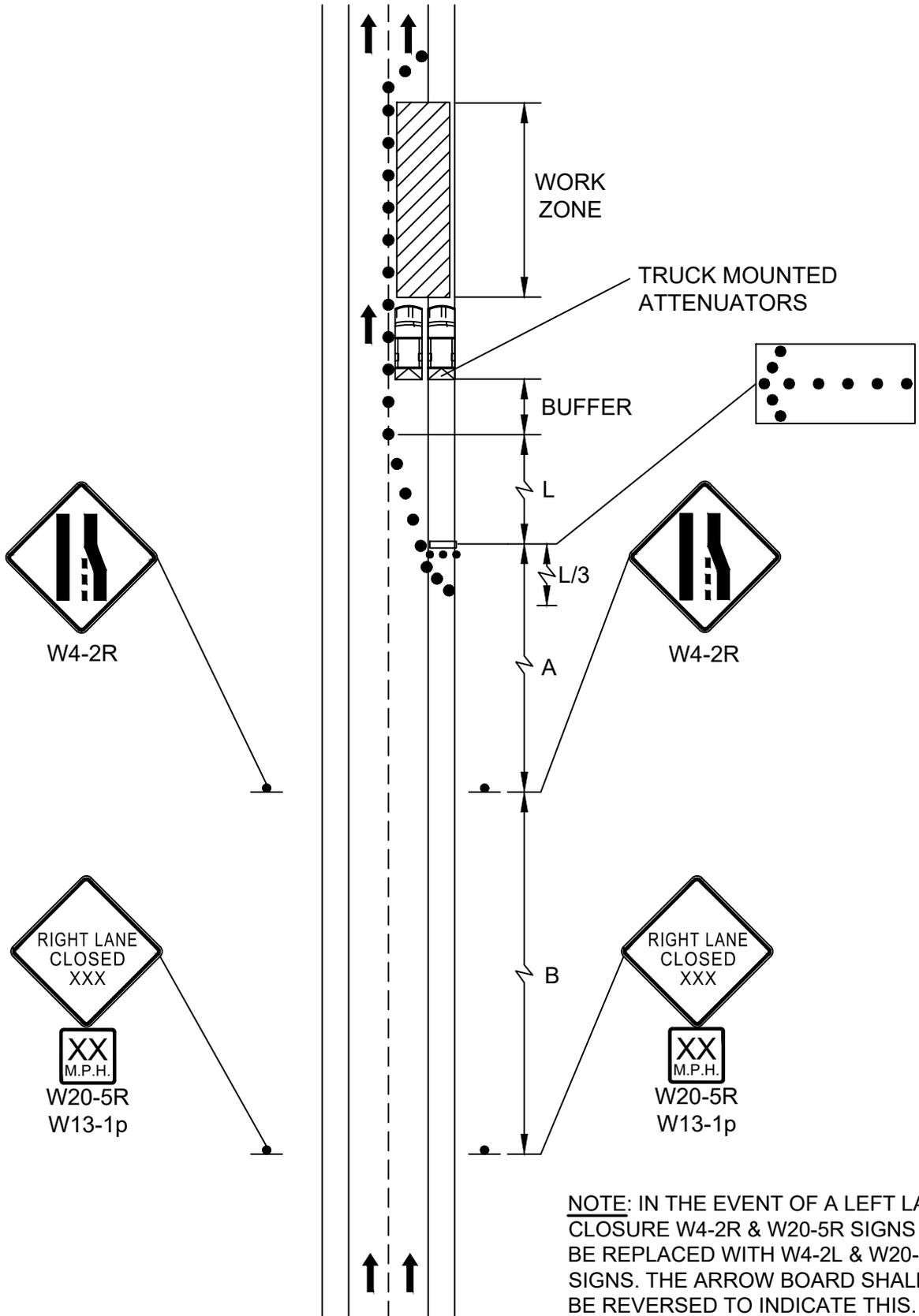

TTCP
DIVIDED HIGHWAY / LANE CLOSURE

DATE:	12/16/2023
SCALE:	NTS
PROJECT NO.:	612097
SHEET	10 OF 22

NOTE: IN THE EVENT OF A LEFT LANE CLOSURE W4-2R & MA-W20-5bR SIGNS SHALL BE REPLACED WITH W4-2L & MA-W20-5bL SIGNS. THE ARROW BOARD SHALL ALSO BE REVERSED TO INDICATE THIS.

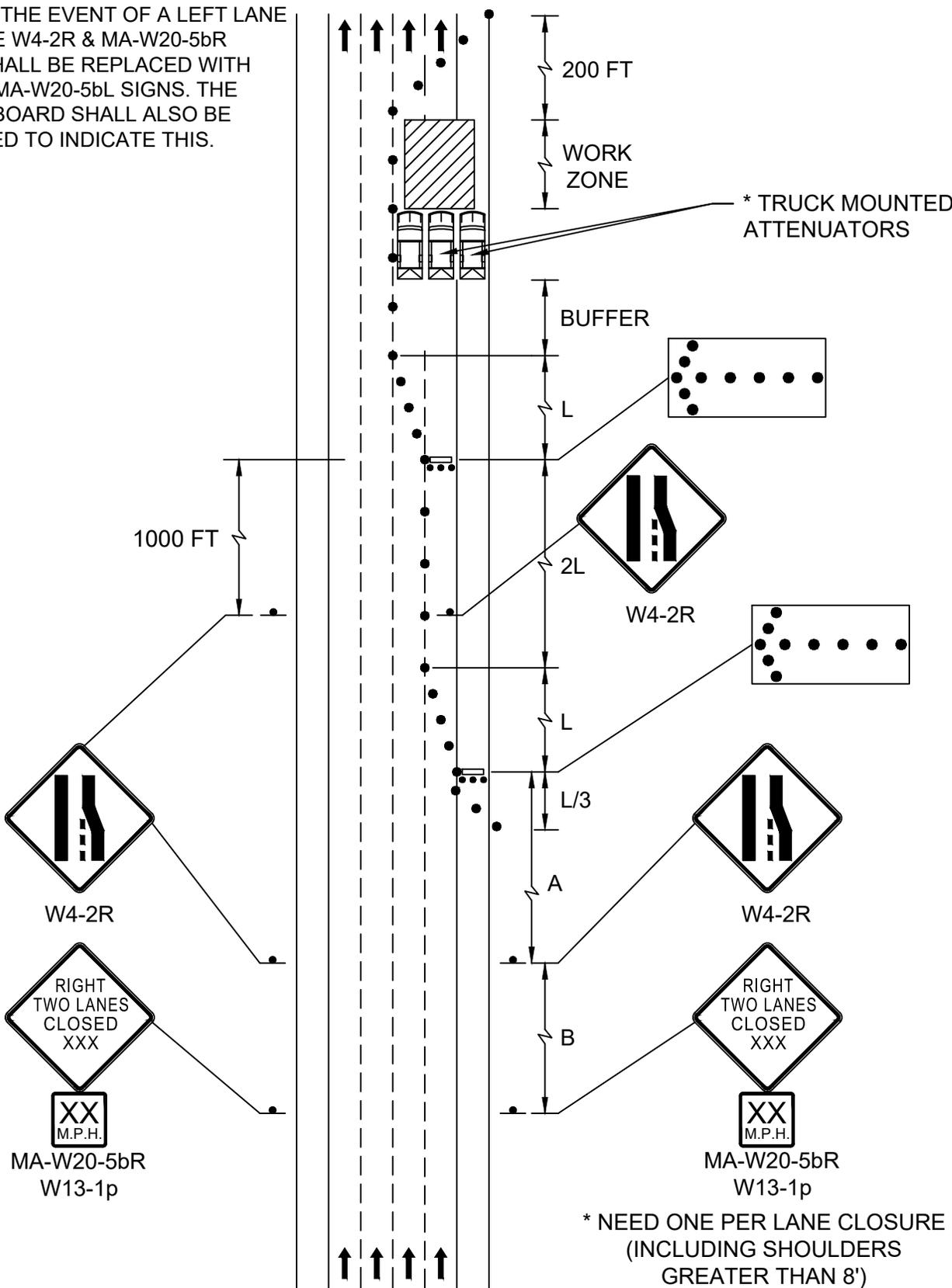

* NEED ONE PER LANE CLOSURE (INCLUDING SHOULDERS GREATER THAN 8')



TTCP
DIVIDED HIGHWAY MULTIPLE LANE CLOSURE

DATE:	12/16/2023
SCALE:	NTS
PROJECT NO.:	612097
SHEET	11 OF 22

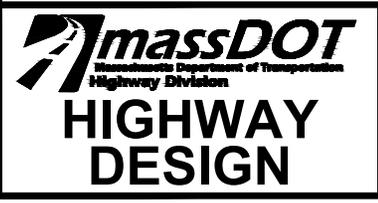
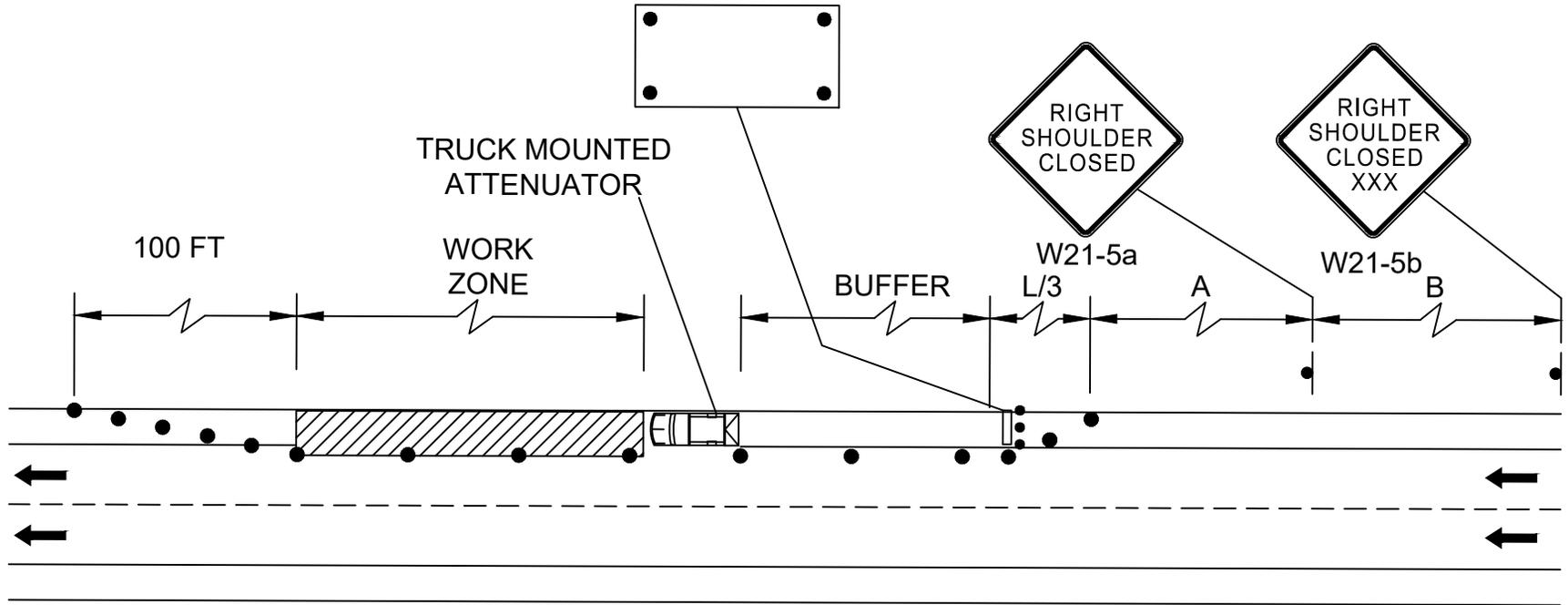

TTCP
DIVIDED HIGHWAY SHOULDER CLOSED

DATE:	12/16/2023
SCALE:	NTS
PROJECT NO.:	612097
SHEET	12 OF 22

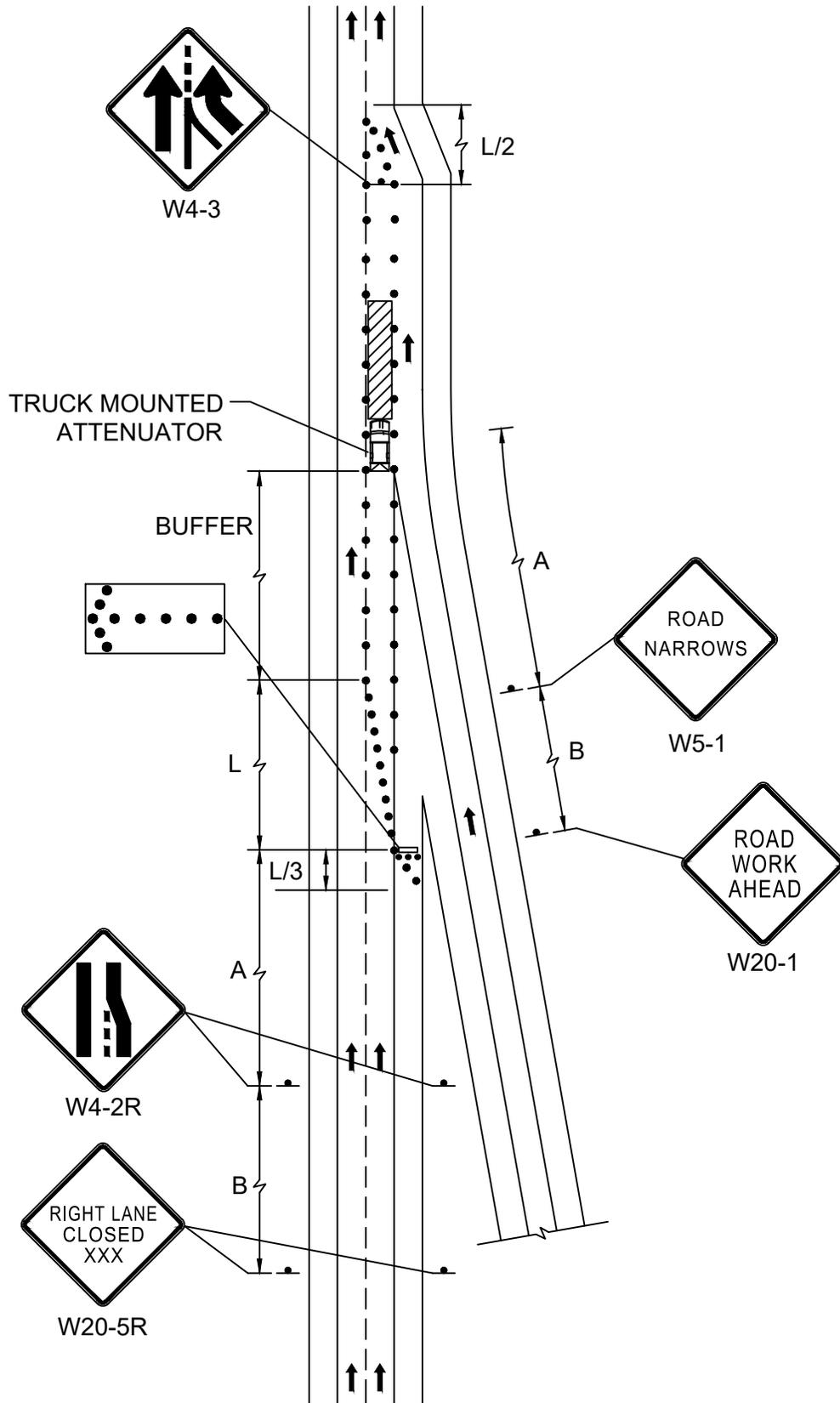

TTCP
WORK AT ENTRANCE RAMP

DATE:	12/16/2023
SCALE:	NTS
PROJECT NO.:	612097
SHEET	13 OF 22

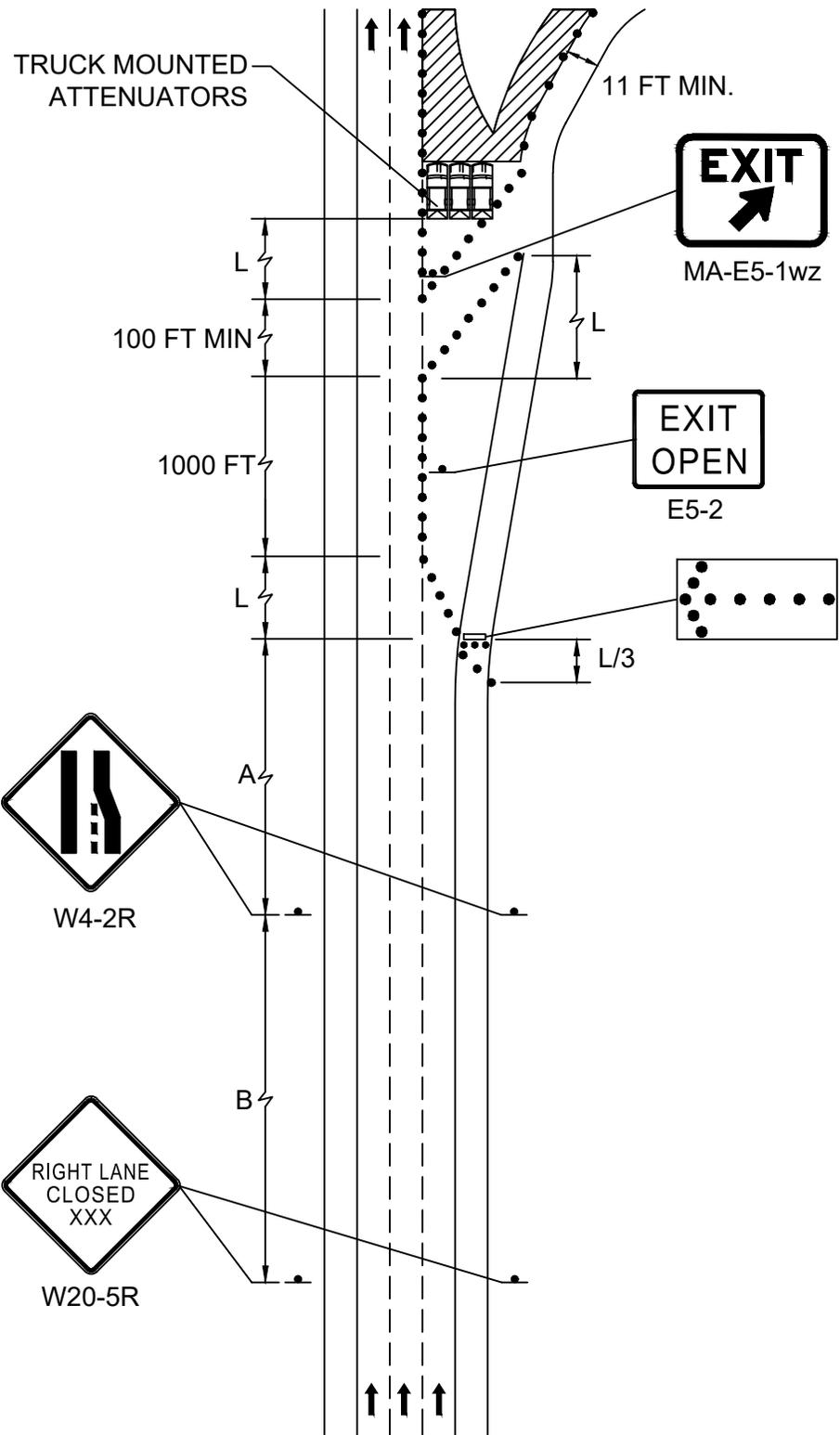

TTCP
 WORK IN VICINITY OF EXIT RAMP

DATE:	12/16/2023
SCALE:	NTS
PROJECT NO.:	612097
SHEET	14 OF 22

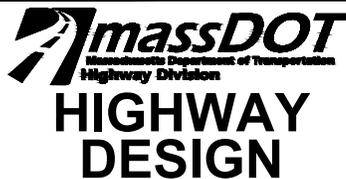
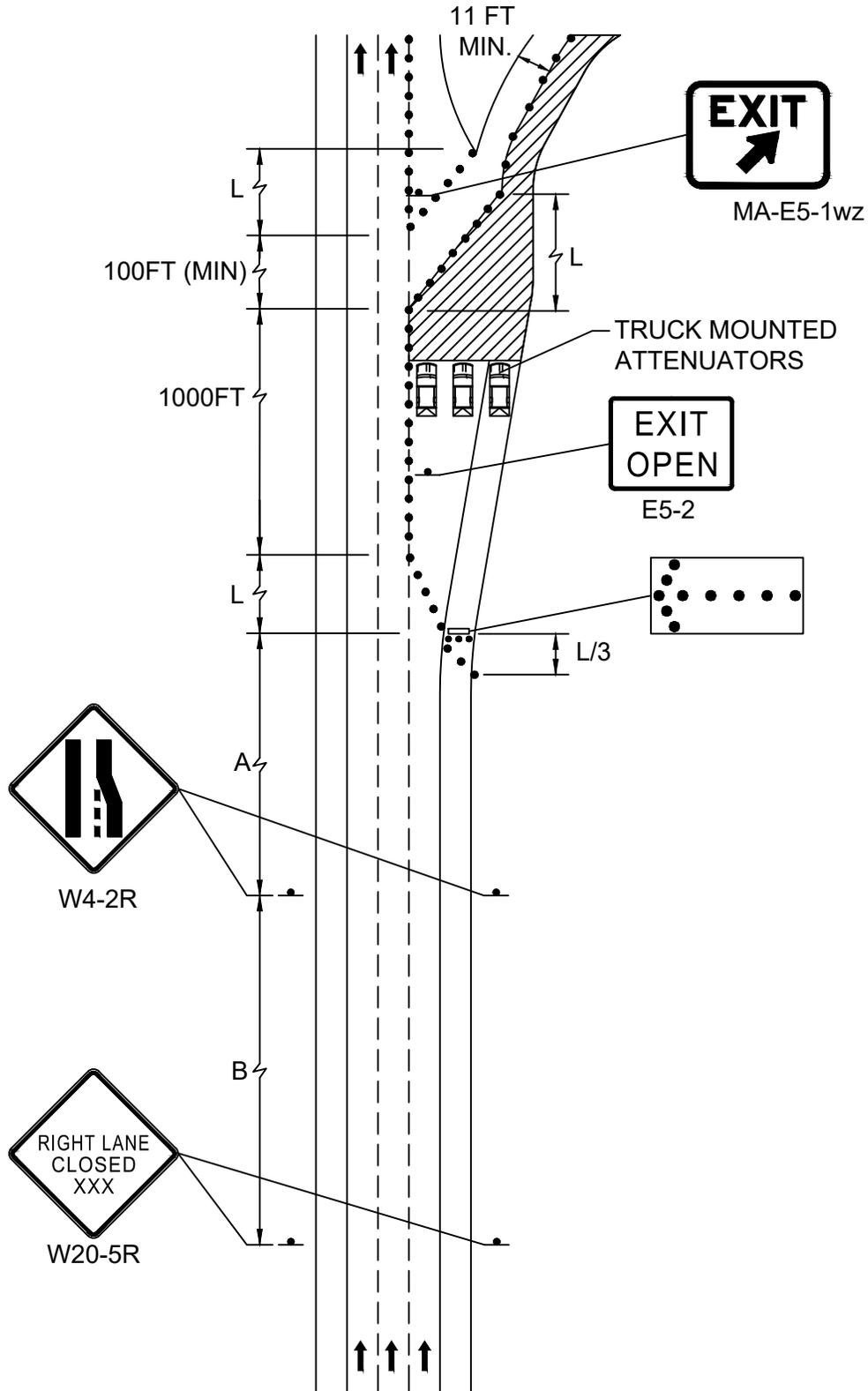

TTCP
WORK IN VICINITY OF EXIT RAMP

DATE:	12/16/2023
SCALE:	NTS
PROJECT NO.:	612097
SHEET	15 OF 22

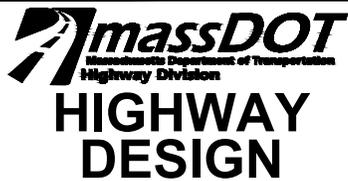
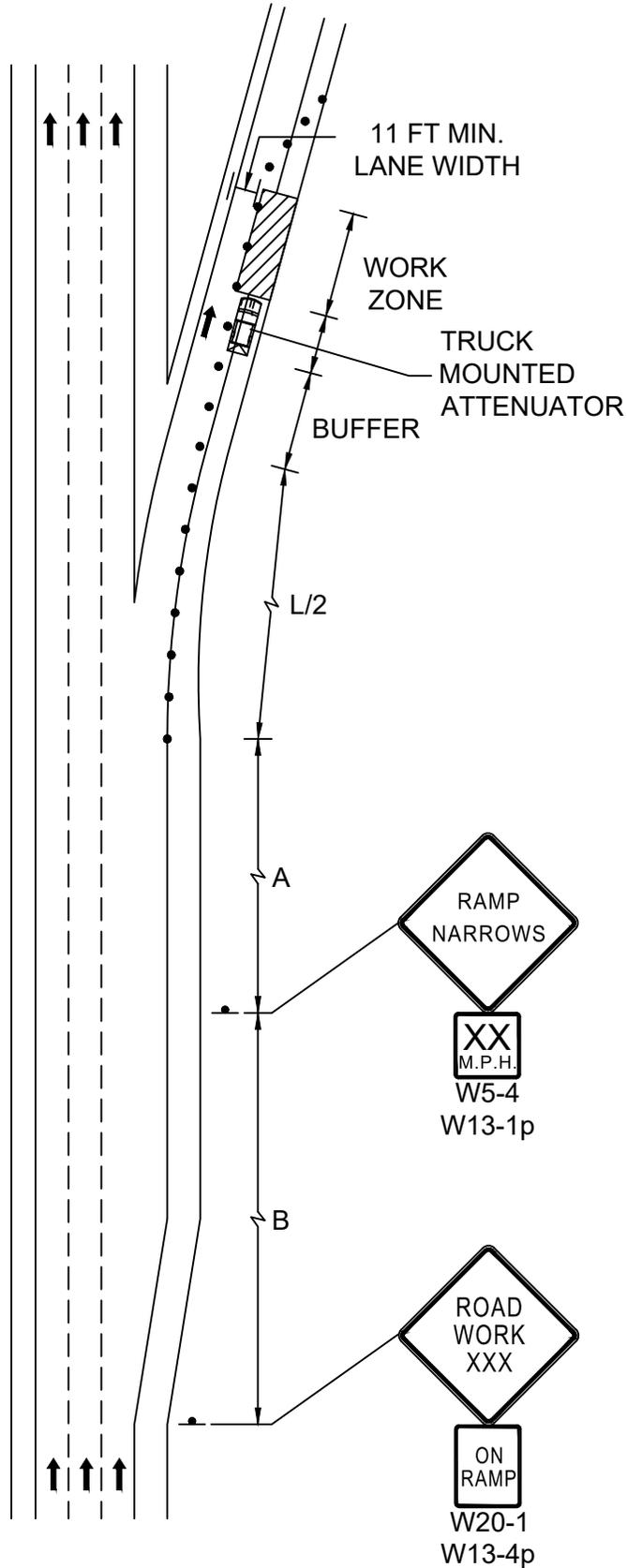

TTCP
PARTIAL EXIT RAMP CLOSURE

DATE:	12/16/2023
SCALE:	NTS
PROJECT NO.:	612097
SHEET	17 OF 22

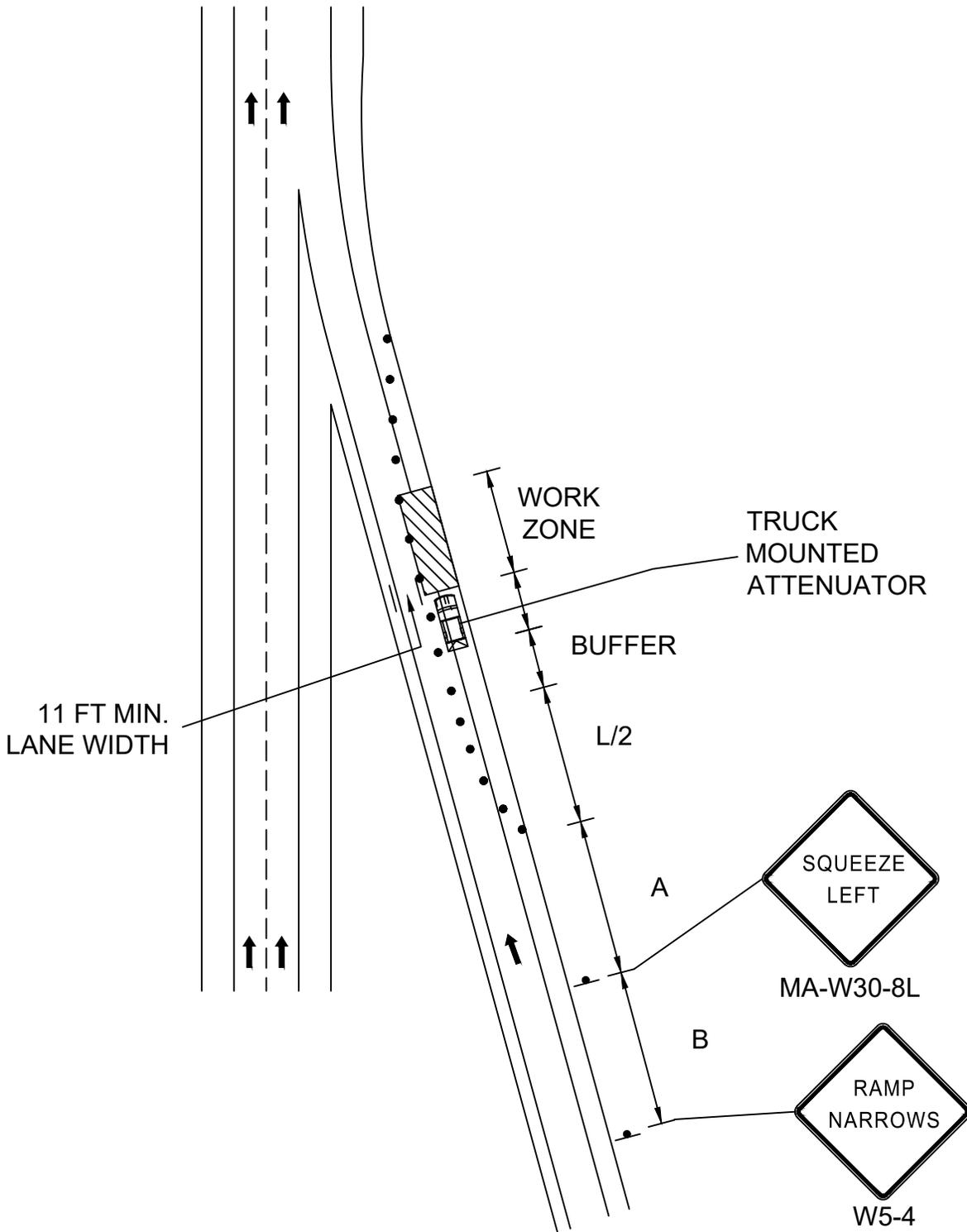

TTCP
PARTIAL ENTRANCE RAMP CLOSURE

DATE:	12/16/2023
SCALE:	NTS
PROJECT NO.:	612097
SHEET	18 OF 22

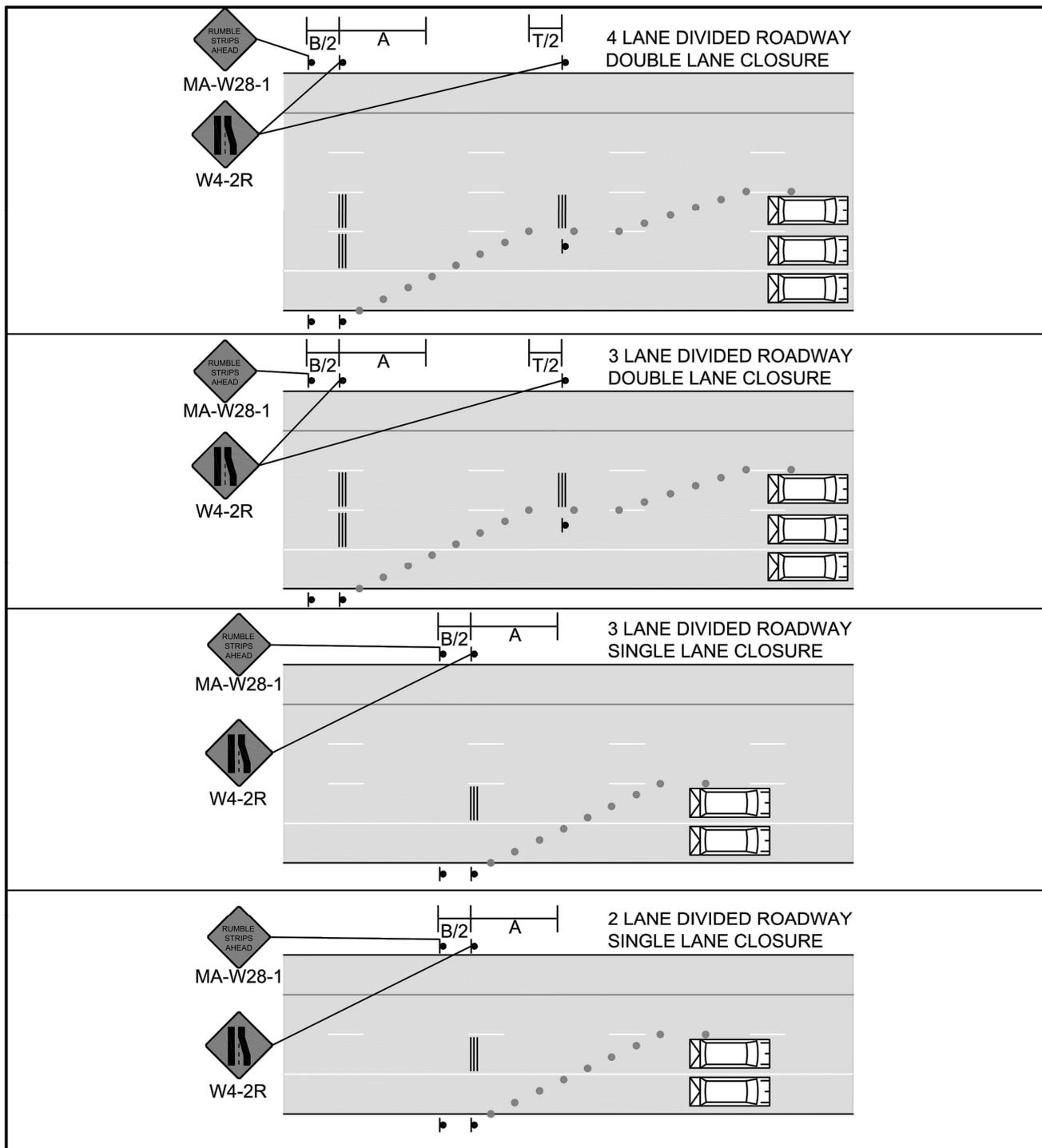

FROM 2023 WORK ZONE SAFETY DRAWINGS



TTCP
TEMPORARY PORTABLE RUMBLE STRIPS

DATE:	12/16/2023
SCALE:	NTS
PROJECT NO.:	612097
SHEET	19 OF 22

IDENTIFICATION NUMBER	SIZE OF SIGN (INCHES)		TEXT	TEXT DIMENSIONS (INCHES)		NUMBER OF SIGNS REQ'D	COLOR			(POST SIZE) AND NUMBER REQUIRED	UNIT AREA (S.F.)	TOTAL AREA (S.F.)
	WIDTH	HEIGHT		LETTER HEIGHT	VERTICAL SPACING		BACKGROUND	LEGEND	BORDER			
W20-1c	48	48		PER MUTCD OR MASSDOT LATEST STANDARDS		6	Fluorescent orange	Black	Black	12	16.00	96.00
W20-1a	48	48				2	Fluorescent orange	Black	Black	4	16.00	32.00
W20-1b	48	48				2	Fluorescent orange	Black	Black	4	16.00	32.00
G20-1	36	18				2	Fluorescent orange	Black	Black	2	4.50	9.00
MA-R2-10e	48	60				4	Fluorescent orange/White	Black	Black	8	20.00	80.00
MA-R2-10a	60	48				4	Fluorescent orange/White	Black	Black	8	20.00	80.00
W8-1	48	48				4	Fluorescent orange	Black	Black	8	16.00	64.00
MA-W30-8L	48	48				2	Fluorescent orange	Black	Black	4	16.00	32.00
W8-15	48	48				4	Fluorescent orange	Black	Black	8	16.00	64.00
MA-W20-5bR	48	48				3	Fluorescent orange	Black	Black	6	16.00	48.00

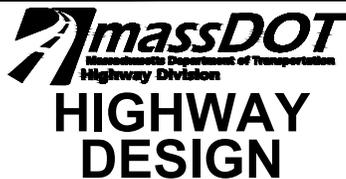

TTCP

TEMPORARY SIGN SUMMARY

DATE:	12/16/2023
SCALE:	NTS
PROJECT NO.:	612097
SHEET	20 OF 22

IDENTIFICATION NUMBER	SIZE OF SIGN (INCHES)		TEXT	TEXT DIMENSIONS (INCHES)		NUMBER OF SIGNS REQ'D	COLOR			(POST SIZE) AND NUMBER REQUIRED	UNIT AREA (S.F.)	TOTAL AREA (S.F.)
	WIDTH	HEIGHT		LETTER HEIGHT	VERTICAL SPACING		BACK-GROUND	LEGEND	BORDER			
W8-15P	36	30		PER MUTCD OR MASSDOT LATEST STANDARDS		4	Fluorescent orange	Black	Black	0	7.50	30.00
W4-2R	48	48		↓	↓	4	Fluorescent orange	Black	Black	8	16.00	64.00
W20-5R	48	48		↓	↓	6	Fluorescent orange	Black	Black	12	16.00	96.00
W13-1P	30	30		↓	↓	5	Fluorescent orange	Black	Black	0	6.25	31.25
W21-5a	48	48		↓	↓	1	Fluorescent orange	Black	Black	2	16.00	16.00
W21-5b	48	48		↓	↓	1	Fluorescent orange	Black	Black	2	16.00	16.00
W4-3	48	48		↓	↓	1	Fluorescent orange	Black	Black	2	16.00	16.00
W5-1	48	48		↓	↓	2	Fluorescent orange	Black	Black	4	16.00	32.00
W4-1R	48	48		↓	↓	1	Fluorescent orange	Black	Black	2	16.00	16.00



TTCP
TEMPORARY SIGN SUMMARY

DATE: 12/16/2023
 SCALE: NTS
 PROJECT NO.: 612097
 SHEET 21 OF 22

IDENTIFICATION NUMBER	SIZE OF SIGN (INCHES)		TEXT	TEXT DIMENSIONS (INCHES)		NUMBER OF SIGNS REQ'D	COLOR			(POST SIZE) AND NUMBER REQUIRED	UNIT AREA (S.F.)	TOTAL AREA (S.F.)
	WIDTH	HEIGHT		LETTER HEIGHT	VERTICAL SPACING		BACK-GROUND	LEGEND	BORDER			
W5-4	48	48		PER MUTCD OR MASSDOT LATEST STANDARDS		3	Fluorescent orange	Black	Black	6	16.00	48.00
W4-2L	48	48				4	Fluorescent orange	Black	Black	8	16.00	64.00
W13-4p	36	36				1	Fluorescent orange	Black	Black	0	9.00	9.00
MA-E5-1wz	48	48				2	Fluorescent orange	Black	Black	4	16.00	32.00
E5-2	48	36				2	Fluorescent orange	Black	Black	4	12.00	24.00
R1-2	48	48				1	White	Red	Red	1	8.00	8.00
W3-2	48	48				1	Fluorescent orange	Black	Black	2	16.00	16.00
W20-5L	48	48				4	Fluorescent orange	Black	Black	8	16.00	64.00
W21-5aL	48	48				1	Fluorescent orange	Black	Black	2	16.00	16.00
W21-5bL	48	48				1	Fluorescent orange	Black	Black	2	16.00	16.00
MA-W28-1	48	48				2	Fluorescent orange	Black	Black	4	16.00	32.00



TTCP
TEMPORARY SIGN SUMMARY

DATE: 12/16/2023
SCALE: NTS
PROJECT NO.: 612097
SHEET 22 OF 22



**WORK
ZONE
SAFETY**

Temporary Traffic Control

*Typical Details and
Massachusetts Guidelines
for MassDOT, Municipalities,
Utilities, and Contractors*

SHEET INDEX (1 OF 3)

<u>GENERAL</u>	<u>PAGE</u>
NOTES AND GUIDELINES.....	1-9
FIG. 1: TYPICAL TRAFFIC CONTROL DEVICES.....	10
FIG. 2: PAVEMENT EDGE DROP-OFF GUIDANCE.....	11
FIG. 3: TYPICAL DEVICE SPACING; (AT 30 MPH).....	12-13
FLAGGING GUIDANCE.....	14-15
FIG. 4-5: TYPICAL PEDESTRIAN DEVICES.....	16-17
 <u>STATIONARY OPERATIONS</u>	
FIG. 6: TWO LANE UNDIVIDED ROADWAY; HALF OF ROADWAY CLOSED; WORK NEAR CURVE.....	18-19
FIG. 7: TWO LANE UNDIVIDED ROADWAY; HALF OF ROADWAY CLOSED.....	20-21
FIG. 8: TWO LANE UNDIVIDED ROADWAY; SHOULDER CLOSED.....	22-23
FIG. 9: TWO LANE UNDIVIDED ROADWAY WITH TRAVERSABLE SHOULDER; HALF OF ROADWAY CLOSED; MAINTAIN TWO-WAY TRAFFIC.....	24-25
FIG. 10: FOUR LANE UNDIVIDED ROADWAY; RIGHT LANE CLOSED.....	26-27
FIG. 11: FOUR LANE UNDIVIDED ROADWAY; LEFT LANE CLOSED.....	28-29
FIG. 12: FOUR LANE UNDIVIDED ROADWAY; HALF OF ROADWAY CLOSED.....	30-31
FIG. 13: MULTILANE DIVIDED ROADWAY; RIGHT LANE CLOSED.....	32-33
FIG. 14: MULTILANE DIVIDED ROADWAY; LEFT LANE CLOSED.....	34-35
FIG. 15: MULTILANE DIVIDED ROADWAY; CENTER LANE OR RIGHT/CENTER LANES CLOSED.....	36-37
FIG. 16: MULTILANE DIVIDED ROADWAY; CENTER LANE OR LEFT/CENTER LANES CLOSED.....	38-39

SHEET INDEX (2 OF 3)

<u>STATIONARY OPERATIONS (CONT.)</u>	<u>PAGE</u>
FIG. 17: MULTILANE DIVIDED ROADWAY; RIGHT SIDE OF OFF RAMP CLOSED.....	40-41
FIG. 18: MULTILANE DIVIDED ROADWAY; LEFT SIDE OF OFF RAMP CLOSED.....	42-43
FIG. 19: MULTILANE DIVIDED ROADWAY; ROADWORK BEYOND ON RAMP.....	44-45
FIG. 20: MULTILANE DIVIDED ROADWAY; ROADWORK BEYOND OFF RAMP.....	46-47
FIG. 21: MULTILANE DIVIDED ROADWAY; TYPICAL RAMP CLOSURE.....	48-49
FIG. 22: MULTILANE DIVIDED ROADWAY; TYPICAL CLOVERLEAF RAMP CLOSURE.....	50-51
FIG. 23: MULTILANE DIVIDED ROADWAY; TYPICAL RAMP CLOSURE; ADVANCE SIGNING.....	52-53
FIG. 24: FOR MULTILANE DIVIDED ROADWAY; PLACEMENT OF TEMPORARY PORTABLE RUMBLE STRIPS.....	54-55
 <u>MOBILE OPERATIONS</u>	
NOTES FOR MOBILE OPERATIONS.....	56
FIG. 25: ANY ROADWAY; BEYOND RIGHT SHOULDER.....	57
FIG. 26: ANY ROADWAY; SHOULDER.....	58
FIG. 27: DIVIDED ROADWAY; MEDIAN WORK.....	59
FIG. 28: UNDIVIDED TWO LANE ROADWAY; HALF OF ROADWAY CLOSED.....	60
FIG. 29: MULTILANE DIVIDED ROADWAY; LEFT LANE.....	61
FIG. 30: MULTILANE DIVIDED ROADWAY; RIGHT LANE.....	62
FIG. 31: MULTILANE DIVIDED ROADWAY; CENTER LANE.....	63
FIG. 32: POST-STORM CLEANUP OPERATION.....	64

SHEET INDEX (3 OF 3)

<u>EMERGENCY RESPONSE</u>	<u>PAGE</u>
NOTES FOR TRAFFIC EMERGENCY/INCIDENT OPERATIONS...	65
FIG. 33: ANY ROADWAY; SHOULDER ENCROACHMENT.....	66
FIG. 34: TWO LANE ROADWAY; NO SHOULDER; TRAVEL LANE ENCROACHMENT.....	67
FIG. 35: TWO LANE ROADWAY; TRAVERSABLE SHOULDER; SINGLE LANE ENCROACHMENT.....	68
FIG. 36: TWO LANE ROADWAY; TRAVERSABLE SHOULDER; CENTER OF ROADWAY.....	69
FIG. 37: MULTILANE DIVIDED ROADWAY; RIGHT LANE.....	70
FIG. 38: MULTILANE DIVIDED ROADWAY; LEFT LANE.....	71
FIG. 39: MULTILANE UNDIVIDED ROADWAY; LEFT LANE.....	72
FIG. 40: MULTILANE DIVIDED ROADWAY; MIDDLE LANE; APPROACH FROM LEFT.....	73
FIG. 41: MULTILANE DIVIDED ROADWAY; MIDDLE LANE; APPROACH FROM RIGHT.....	74
 <u>TRAFFIC SIGNAL REPAIR WORK AT INTERSECTION</u>	
FIG. 42: MULTILANE UNDIVIDED ROADWAY; LEFTMOST OR LEFT TURN LANE.....	75
FIG. 43: TWO LANE UNDIVIDED ROADWAY; ONE LEG OF INTERSECTION.....	76
FIG. 44: MULTILANE UNDIVIDED ROADWAY; CENTER OF INTERSECTION.....	77
 <u>PEDESTRIAN DETAILS</u>	
FIG. 45: PEDESTRIAN BYPASS.....	78
FIG. 46: TEMPORARY SIDEWALK CLOSURE.....	79
 <u>BIKE LANE DETAILS</u>	
FIG. 47: BIKE LANE CLOSURE.....	80-81

INTRODUCTION

This guide has been prepared to assist in the planning and installing of temporary traffic controls in maintenance, utility, or short-term construction work areas (work lasting 10 hours or less). This guide serves to assist with the many decisions that must be made for each work site. Special planning for traffic control is necessary on a case by case basis because conditions can vary widely among work locations. **Since this guide cannot cover every situation, representative illustrations covering typical short-term construction, maintenance, and utility operations are presented.**

All typical traffic control device setups illustrated should be considered as guides. The traffic control devices that are shown, the arrangement or position of the devices, and the distances prescribed in the tables are based on the Federal Highway Administration's (FHWA) Manual on Uniform Traffic Control Devices (MUTCD) and the Massachusetts Amendments to the MUTCD (MA Amendments), but these illustrations only present minimum standards. The provision of safe work zones for all roadway users and roadway workers affected by these activities is paramount. Traffic controls may be expanded or improved upon whenever deemed necessary. Traffic movement through the work site all traffic control devices shall be periodically observed and inspected at all locations.

If necessary, Part 6 of the MUTCD and the MA Amendments, Chapter 17 (Work Zone Management) of MassDOT's Project Development & Design Guide, and the "Traffic Engineering and Safety Section" of the MassDOT web site: (<https://www.massdot.state.ma.us/highway/Departments/TrafficandSafetyEngineering.aspx>), as well as MassDOT District offices can provide additional guidance, information, and suggestions for work zone setups.

RESPONSIBILITIES FOR TRAFFIC CONTROL

Short-term construction, maintenance, and utility work on or near the roadway creates a potentially hazardous situation, typically requiring the use of temporary traffic controls. These controls are important to protect both work crews and the road users. It is the responsibility of each maintenance foreman to establish and maintain safe and effective controls.

Usually the supervisor, working with the crew, plans the traffic control procedures for proposed work sites. The foreman is responsible for re-requesting, storing, and maintaining all traffic control devices necessary for their crews.

The foreman is responsible for placing the devices according to these guidelines. They must inspect each installation and observe traffic flow through the area. The foreman is generally authorized to make adjustments to the original installations that, in their judgment, are necessary to improve the control of traffic and establish greater safety.

All necessary traffic control devices must be installed before work begins and properly maintained during the work period. They must also be removed as soon as they are no longer relevant to the roadway conditions.

PAGE 2

In situations such as night time road or lane closures, detours, or other unusual conditions on state highways, the District Traffic Maintenance Engineer (DTME) should be advised. If the DTME is absent, the section foreman shall follow the instructions of the District Maintenance Engineer.

TRAFFIC CONTROL DEVICES

Traffic control devices regulate the movement of road users, warn of unexpected or unusual roadway conditions, and inform them how to maneuver safely through or around the work area. All signs, channelizing devices, barricades, and other miscellaneous traffic control devices should work together to guide traffic safely and efficiently. Common temporary traffic control devices are outlined and described below.

Signs

Temporary traffic control zone (TTCZ) signs are the primary means of providing information and directions to roadway users. All signs must be retroreflective per MassDOT's latest standard.

Warning signs call attention to unexpected conditions and to situations that might not be readily apparent to road users on or adjacent to a roadway. Warning signs alert road users to conditions that might call for a reduction of speed or an action in the interest of safety and efficient traffic operations. Nearly all warning signs for construction and work areas have black legends and borders on a fluorescent orange background.

Regulatory signs shall be used to inform road users of selected traffic laws or regulations and indicate the applicability of the legal requirements. Regulatory signs typically have black legends and borders on a white background.

Channelizing Devices

When used properly, traffic cones, reflectorized plastic drums, and barricades guide traffic through the work area along an appropriate travel path. It takes roadway users a certain distance along the roadway to safely move away from the upcoming active work site. These transition distances are based on the following taper length (L) formulas:

$L = WS^2/60$ for speeds of 40 mph or less; or

$L = WS$ for speeds of 45 mph or more; where

- L = minimum length of taper in feet,
- S = posted speed limit or typical travel speed in miles per hour prior to the work, and
- W = width of lane closure in feet.

The spacing of channelizing devices (in feet) is approximately equal to the existing speed of traffic (in mph).

Warning Lights

Rotating beacons and other flashing lights mounted on work vehicles, signs, or channelizing devices help alert roadway users to the work area. They may also be used to warn roadway users of hazards within the work area. The first 10 drums in any taper shall be equipped with sequential flashing lights.

Arrow Boards

Arrow boards are a special type of sign that are highly visible work zone warning devices. They are particularly effective on highways, where both speed and volume are high. Arrow boards in the non-directional, CAUTION, mode (four corner flashing) may be used to indicate that a shoulder is closed. Arrow boards in the arrow mode shall only be used when a travel lane is dropped on a multi-lane road and one lane of traffic must merge with another. All arrow boards should be located at the beginning of each lane or shoulder closure taper without extending outside of it. Arrow boards shall flash at a rate of 25 to 40 flashes per minute. Arrow boards shall not be used to indicate a lane shift.

BASIC REQUIREMENTS

In every work situation, the temporary traffic control setup must: Give roadway users sufficient advance warning of the work area; advise roadway users of the proper actions to take and travel paths to follow; and provide protection to roadway users, workers, and the work area. These three general requirements can be met as outlined below.

Provide Advance Warning

Warning devices along the approaches to a work area alert roadway Users to changes to road and operating conditions. Roadway users are usually alerted to these dangers via a sign or series of signs installed in the same order as the roadway user generally would expect to see them on long-term construction projects.

The initial project limit sign is usually a general warning such as "ROAD WORK 1500 FT". Other operational warning signs then provide the roadway user with more specific information about the situation. A minimum of three advance warning signs (the initial project limit sign and two operational warning signs) is recommended when work is located on the traveled way. Warning lights and flags can be used to attract attention to the signs. A highly visible work area helps reinforce the advance warnings.

Advise and Direct Travelers

Operational warning signs provide information to the road-way user such as the type of work being performed, special conditions to watch for, or actions to take. These include signs such as, SHOULDER WORK, RIGHT LANE CLOSED, DETOUR 500 FT, ROAD CLOSED to THRU TRAFFIC, POLICE OFFICER AHEAD, etc. All of these signs must be located far enough in advance of the work area that the roadway user has sufficient time to react to them appropriately. For projects in Urban Areas, see detail: Typical Device Spacing for minimum sign spacing.

Protect Travelers, Workers, and the Work Area

The primary protection of any work area is its own visibility. Traffic cones, reflectorized plastic drums, portable breakaway barricades, etc. are used to make the work area visible and separate workers from traffic.

PAGE 4

Other devices, such as flashing lights, flags, delineators, temporary lighting, and portable changeable message signs (PCMS) can be used to provide additional emphasis and visibility.

Workers must protect themselves by being alert to their work situation, wearing safety vests and hard hats, and by facing traffic whenever possible.

Work vehicles can also add protection when they are equipped with truck mounted attenuators, rotating beacons, flashing lights, flashing arrow boards, etc. and are parked between workers and oncoming traffic. However, workers should not position themselves between two closely parked vehicles. No private personal vehicles are allowed within the work site.

PLANNING GUIDELINES

Decisions regarding selection of work area traffic control devices require a knowledge and understanding of the specifics of each work zone. As there may be vast differences between situations, three main variables need to be considered prior to determining the need for, or the selection of, traffic control devices: 1) location of work, 2) type of roadway, and 3) speed of traffic.

Compiling information about these variables will help with planning a safe work area control. Each of these variables is explained below.

Location of Work

The choice of traffic controls needed for a short-term construction, maintenance, or utility operation depends upon the work zone's location. As a general rule, the closer the active work site is to the roadway, the more control devices are needed. Work can take place:

- Away from the shoulder or edge of pavement. No special devices are needed if work is confined to an area 15 or more feet from the edge of the shoulder. A general warning sign, such as ROAD WORK AHEAD, should be used if workers and equipment must occasionally move closer to the roadway.
- On or near the shoulder/ edge of pavement. This area should be signed as if work were on the road itself, since it is part of the roadway users' recovery area. Advance warning and operational signs are needed, as well as channelization devices to direct traffic and keep the work area visible to roadway users.
- On the median of a divided highway. Work in this location may require traffic control in both directions of traffic. Advance warning and channelization devices should be used if the median is narrow.
- On the roadway. This condition requires detailed protection for workers and sufficient warning to roadway users. Advance warning must provide a general message that work is taking place as well as information about specific hazards and specific actions the roadway user must take.

TYPE OF ROADWAY

The characteristics of the roadway also have an important influence on the selection of work area traffic control. The roadway, itself, may present special hazards. You should plan for maximum protection, using the worst hazard present as your guide to signing the work area. Some general considerations are described below for road conditions.

One-way roads: A one-way road requires signage on both sides of the road if it carries two or more lanes in one direction, ensuring roadway users in all lanes are alerted and informed.

Two-way roads:

- **Undivided:** Two-way, undivided roads will usually require controls for both directions of traffic. When the active work site is well off the roadway, controls for the opposite lane may be eliminated.
- **Divided:** Work on divided multi-lane roadways can often be handled as work along a one-way road (i.e. signs are provided along both sides of the roadway along the direction affected). If the work is in the median, both directions of traffic must be controlled, and both approaches should be double signed (i.e. have all 3 advance warning signs on both sides of each direction).

EFFECTS OF SPEED ON WORK ZONES

Speed is an important consideration in the use of work area traffic control devices. As a general rule, the greater the speed of traffic approaching a work area, the greater the size, number, and spacing of control devices.

Size. The standard size for most warning signs is 36 x 36 inches on conventional roadways and 48 x 48 inches on freeways and expressways. Signs larger than the standard 36 x 36 inches may be desirable on high-speed conventional roads.

Position. Install signs far enough in advance of the work area so the roadway users have time to react to them (see charts associated with diagrams for spacing).

OTHER FACTORS

Sight Obstructions. To ensure safety, work areas must be visible. Assess the placement of the temporary traffic control devices by driving through the area, and determine if the devices can be easily seen and provide sufficient time for roadway users to react in a safe manner. Extra precaution should be enacted in areas where horizontal or vertical curves may obstruct a roadway user's clear view of road activities ahead.

Police/Flaggers. It should be noted that the MUTCD does not require police/flaggers for stationary setups. If police/flaggers are used, a police/flagger ahead sign should be used in advance of any point where the police/flagger is stationed to control road users.

PROCEDURES FOR WORK AREA TRAFFIC CONTROL

1. PLAN YOUR WORK

Inspect location of work area and its surroundings.

Analyze:

- Location of work in relation to the traveled way, intersecting road-ways, driveways, and sight distances;
- Type of roadway and traffic involved; and
- Volume and speed of traffic.

Meet and discuss the work and necessary traffic control with the crew.

Study representative illustrations in this guide to develop a temporary traffic control plan (TTCP).

Other Considerations:

- Base your traffic control plan on the premise that all roadway users are unfamiliar with the area.
- The closer the work area location is to traffic, the more controls are needed.
- Plan for maximum protection.
- Select and inspect the temporary control devices needed (including all warning signs), if they are not in good condition, REPLACE THEM!
- Then collect and transport them to the work site.
- Determine their proper placement.
- Install signs and other traffic control devices prior to allowing personnel or equipment onto the roadway.
- Make sure signs are reflective, accurate, clean, and meet specifications. Completely cover any existing permanent signs that will conflict with the messages of the new work area control signs.

2. INSTALLING/REMOVING TEMP. TRAFFIC CONTROL DEVICES

Care must be exercised when installing and removing temporary traffic control (TTC) devices. The traffic control needed to perform the operation safely is dictated by the location on the roadway the operation will occur: in a shoulder or a lane, in the left lane or right, etc. In all cases, installing TTC begins and ends as a mobile operation.

A shadow vehicle with a truck mounted attenuator (TMA) shall be used to protect workers installing and removing TTC devices on all roadways with a posted speed limit of 45 MPH or greater as directed by the engineer. TTC devices shall not be installed or removed from a shadow vehicle with a TMA. TTC devices shall be installed or removed from a work operation vehicle only and a shadow vehicle with a TMA shall be used to protect the workers installing or removing the devices.

PROCEDURES FOR WORK AREA TRAFFIC CONTROL (CONT.)

3. INSTALL TRAFFIC CONTROL DEVICES AT WORK SITE

FOR LOWER SPEED (≤ 40 MPH) ROADWAYS:

- 1) All devices shall be installed in order with the flow of traffic.
- 2) Where one direction of traffic is being affected, the first sign installed should be the sign farthest from the work site, and on the same side as the work.
- 3) Where two directions of traffic are affected, install signs for opposing traffic first, starting with the sign farthest from the work area. When signs for opposing traffic have been installed, install signs on the same side as the work area, again beginning with the sign farthest from the active work site.
- 4) Once signs are in place, other traffic control devices shall be installed in the same manner as the signs.

FOR HIGHER SPEED (≥ 45 MPH) ROADWAYS:

- 1) All devices shall be installed in order with the flow of traffic.
- 2) Install all advance warning signs, beginning with the ROAD WORK XXX (W20-1) sign and ending with the END ROAD WORK/DOUBLE FINES END (MA-R2-10E) sign.
- 3) Install all signs beginning with the opposite side which will be closed (for a right lane closure; first, install all signs on the left side (shoulder) and then install all signs on the right side (shoulder). No signs shall be erected on the roadway unless delineated by traffic control devices.
- 4) If required, install shoulder taper as the mobile operation advances.
- 5) Install arrow board on the shoulder prior to the merging taper or as close to the beginning of the merging taper as possible.
- 6) Install channelizing devices to form a merging taper. Use of a shadow vehicle with a TMA during installation is required on roads with speed limits of 45 MPH or greater or as directed by the Engineer.
- 7) Install traffic control devices along the buffer space at the appropriate spacing.
- 8) Continue placing devices along the work space at the appropriate spacing.
- 9) Install devices for the termination area as necessary.
- 10) Place the shadow vehicle with a TMA in advance of the first work crew or hazard approached by motorists. Multiple shadow vehicles may be required based on the number of lane and shoulder closures implemented.

4. INSPECT WORK AREA SIGNING AND CONTROL DEVICES

- 1) Assess the placement of the temporary traffic control devices by driving through the work area. All approaches to the work zone should be checked.
- 2) Ensure roadway users will have sufficient time to read signs and react in a safe manner.

PROCEDURES FOR WORK AREA TRAFFIC CONTROL (CONT.)

- 3) Check visibility of entire work area. If approaching roadway users can't see the work area well, or if they can't see ahead to traffic that may already be queued on the approach because of the work, additional traffic control devices should be deployed.
- 4) Check to ensure the proper temporary traffic control devices are positioned to protect workers from traffic (where possible).
- 5) Ensure all workers wear safety vests, hard hats, and all other necessary safety equipment. All worker safety gear should be in good condition. All reflective gear should be clean and highly visible in the dark.
- 6) Record in the log book the number and location of all signs and devices.

Considerations:

- Work area signs should never be blocked from view or obscured by vegetation, existing signs, or other obstructions.
- Flags, flashing lights, and edge line traffic cones can be used to improve visibility.

5. REMOVE TRAFFIC CONTROL DEVICES AT WORK SITE

All workers and equipment should be clear from work site BEFORE removing signs and other devices.

FOR LOWER SPEED (≤ 40 MPH) ROADWAYS:

- 1) Remove signs and other devices within the delineated area when work is complete.
- 2) Remove other traffic control devices in the reverse order in which they were installed
- 3) Remove signs in the reverse order in which they were installed (i.e. sign closest to the work area to be removed first).
- 4) When the operation is complete, uncover any existing permanent signs covered in Step 2.
- 5) Record in the log book the time at which the signs were removed.

FOR HIGHER SPEED (≥ 45 MPH) ROADWAYS:

All TTC devices for a stationary lane closure on a multi-lane roadway, except advance warning signs, should be removed against the flow of traffic in the following sequence:

- 1) Remove the channelizing devices starting from the end of the activity area working back to the widest part of the merging taper.
- 2) A shadow vehicle with TMA shall be positioned to protect workers removing devices and work backwards as the setup is removed from the roadway.

PROCEDURES FOR WORK AREA TRAFFIC CONTROL (CONT.)

- 3) Place the removal vehicle on the shoulder, and remove the channelizing devices from the merging taper by hand onto the work vehicle.
- 4) Remove the arrow board once traffic is clear and it is safe to do so.
- 5) Circle back and moving with the flow of traffic, remove the advance warning signs starting with the opposite side from previous lane closure first.
- 6) At no time shall workers run across the multilane roadway to remove signs on both sides of the road simultaneously.
- 7) Record in the log book the time at which the signs were removed

RAMP FACILITIES

At all times it is necessary to control the on and off-ramp traffic during the installation and breakdown of traffic control devices. Use of temporary traffic slow-downs or rolling roadblocks is recommended to allow for the safety of workers handing temporary traffic control devices on ramp facilities. A shadow vehicle with a TMA shall be used to protect the workers installing or removing the devices. At no time shall the work operation vehicle be used as the shadow vehicle with the TMA.

USE OF THIS GUIDE

Illustrations showing minimum standards for short-term construction, maintenance, and utility operations are arranged in this guide by type of operation. The users of this guide should compare all illustrated examples and examine their differences. After gathering information about the work zones using the general guidelines as outlined, proceed as follows:

- 1) Turn to the Index. Consider the type of operations and the type of roadway upon which work will occur.
- 2) Select the figure that most closely matches the conditions where you plan to work. Remember that all diagrams represent minimum standards.
- 3) Read the title of the illustration to ensure that it is appropriate to your location. Study the layout of traffic control devices and read all notes.
- 4) Consult the appropriate tables, as directed on each illustration to determine taper length and proper spacing of signs. Notice that distances change when speeds change. Also note that these are guidelines, only, and they must be adapted to your specific work area.
- 5) Use the **“PROCEDURES FOR WORK AREA TRAFFIC CONTROL”** for assistance in completing all necessary steps to provide effective and safe work area traffic control.



SIGN

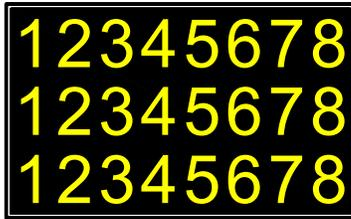

PORTABLE CHANGEABLE MESSAGE SIGN (PCMS)

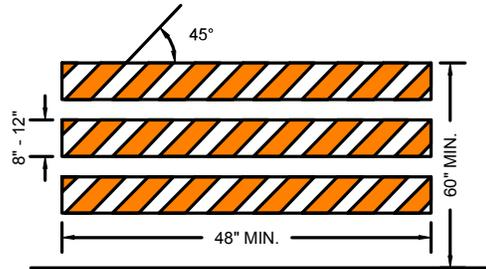

TYPE III BARRICADE

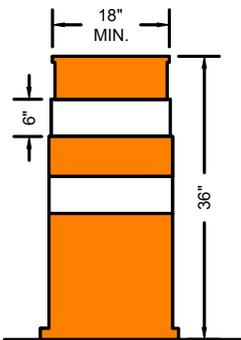

DRUM

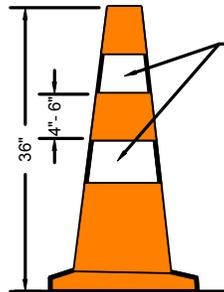

RETROFLECTIVE BANDS

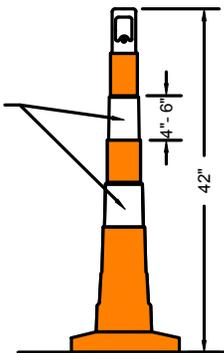

CONES

Cones may be used for all daytime operations. For night work, drums should be used to form the taper(s) and cones can be used along the tangent section of the work setup.

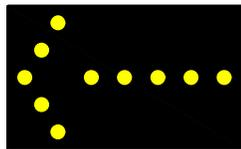

LEFT

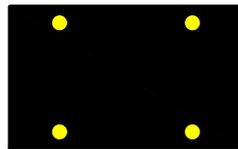

CAUTION

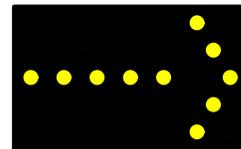

RIGHT

ARROW BOARD (WITH MODE)

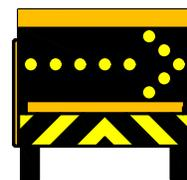

TRUCK MOUNTED ATTENUATORS

Truck Mounted Attenuators (TMA) shall be positioned between the start of the work area and the end of the designated buffer zone. The TMAs are to be positioned in each temporarily closed lane. This includes shoulders (≥ 8 feet) whether combined with a travel lane closure or being closed alone. These TMA conditions are required on roadways with speeds of 45 MPH or greater. TMAs can be used on other roadways at the discretion of the engineer. TMAs shall be used for the deployment and removal of all traffic control devices, including all advance warning signs.

SHORT-TERM PAVEMENT EDGE DROP-OFFS

Note that this guidance is adopted from the Roadside Design Guide, 4th Edition.

Pavement drop-offs may occur during paving, excavation, and other construction activities. Drop-offs create hazards for vehicles if not properly mitigated. The following applies for all roads with speed limits greater than 30 mph; for roads with speed limits of 30 mph or less, treatments for pavement edge drop-offs are at the discretion of the Engineer. Drop-offs between adjacent, open travel lanes should not exceed 2", and any drop-off in excess of 3" should not be left unattended without one of these mitigation measures applied.

- Shoulder drop-offs 3" or less adjacent to a shoulder or active travel lane should be mitigated by:
 - ✓ A W8-9 (LOW SHOULDER) sign in advance of and at regular intervals throughout the treatment; or
 - ✓ The placement of drums on the traffic side of the drop-off.

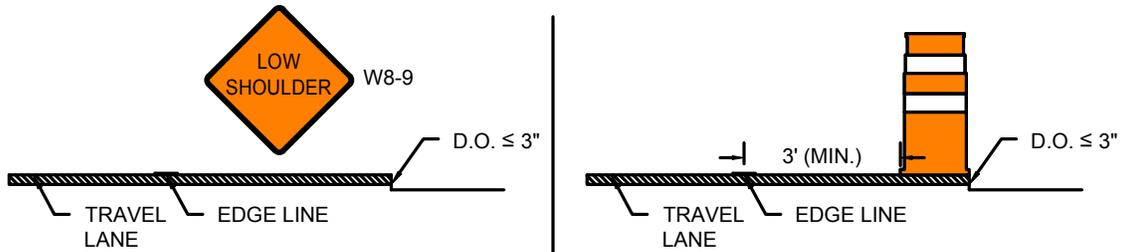

- Shoulder drop-offs greater than 3" but less than or equal to 36" should be mitigated by:
 - ✓ A W8-9 (LOW SHOULDER) sign in advance of and at regular intervals throughout the treatment and the placement of drums on the traffic side off the drop-off, offset at least 3' from the travel lane; or
 - ✓ A W8-9 (LOW SHOULDER) sign in advance of and at regular intervals throughout the treatment and the placement of a temporary wedge of material along the face of the drop-off. The wedge should consist of stable material placed on a 2H:1V or flatter slope.

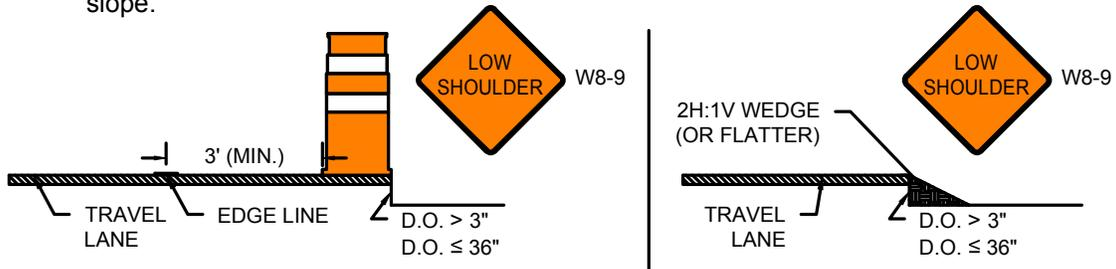

- Shoulder drop-offs greater than 36" must be protected by temporary barrier.

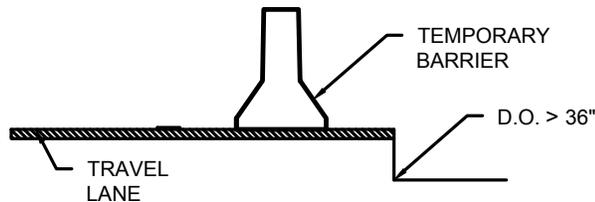



POSTED SPEED LIMIT (MPH)	SPACING FOR ADVANCE WARNING SIGNS (FT) (A,B,C)	CHANNELIZATION DEVICES (DRUMS OR CONES)			
		TRAVEL LANE CLOSURE LENGTH (L) (FT)	BUFFER ZONE LENGTH (FT)	DEVICE SPACING (FT)	MIN # OF DEVICES*
25-40	500 / 500 / 500	320	305	20	55
45-55	500 / 1000 / 1000	660	495	40	40
60-65	1000 / 1600 / 2600	780	645	40	50

* NUMBER OF DEVICES BASED ON 400 FT WORK ZONE.

MINIMUM SPACING OF ADVANCE WARNING SIGNS FOR URBAN ROADWAYS	
ROAD TYPE	DISTANCE BETWEEN SIGNS
URBAN (LOW SPEED)	100 FT
URBAN (HIGH SPEED)	350 FT

NOTES

1. 40 FT = 10 FT PAVEMENT MARKING + 30 FT SKIP

LEGEND

-  WORK ZONE
-  CHANNELIZATION DEVICE
-  FLASHING ARROW BOARD
-  PORTABLE CHANGEABLE MESSAGE SIGN
-  TRUCK MOUNTED ATTENUATOR
-  RADAR SPEED FEEDBACK BOARD
-  POLICE DETAIL OR UNIFORMED FLAGGER
-  TEMPORARY PORTABLE RUMBLE STRIP
-  TYPE III BARRICADE

NOT TO SCALE

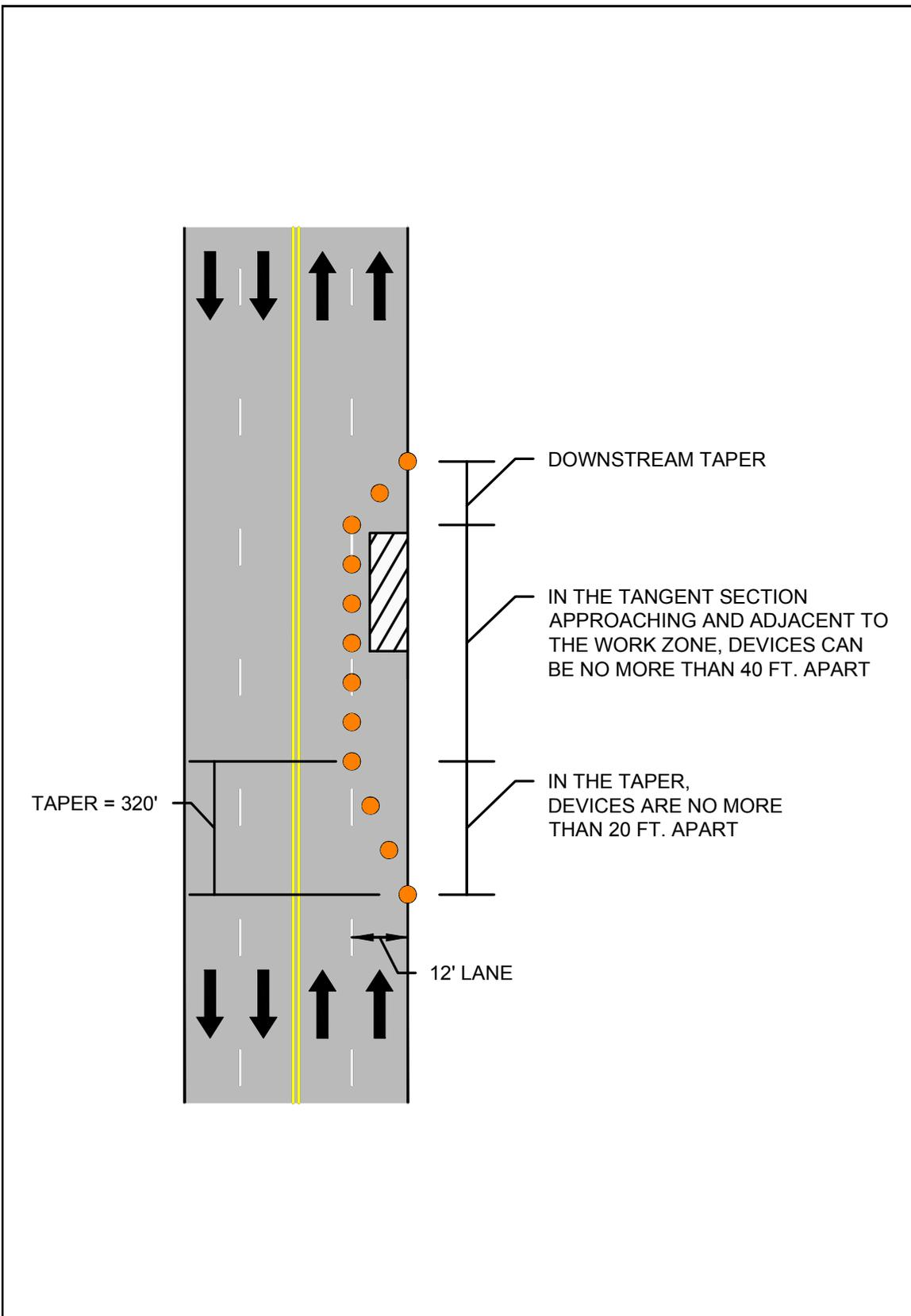

 <p>PAGE 14</p>	<p>Work Zone Safety Standard Details and Drawings</p>	<p>FLAGGING GUIDANCE</p>
--	---	--------------------------

Guidance for Flagging Operations

NOTE:

A flagger shall always be aware of their surroundings and have a good escape route. A flagger shall never be positioned directly beside or against construction equipment. When a flagger is required to direct traffic in an area where the escape route is partially blocked by a traversable obstruction such as a guardrail, the flagger shall be physically capable of traversing that obstruction. Prior to commencing a project, the supervisor in charge shall review the project, including guardrail areas, for safe flagging stations. The supervisor in charge shall clearly communicate with the flagger(s), indicating any locations where they cannot safely perform their duties.

Each flagger shall be equipped with the following high visibility clothing, signaling, and safety devices:

- 1) A white protective hard hat with a minimum level of reflectivity per the requirements of ANSI, Type I, Class E&G;
- 2) A clean, unfaded, untorn lime/yellow reflective safety vest and pants meeting the requirements of ANSI 107 Class 3 with the words "Traffic Control" on the front and rear panels in minimum two (2) inch (50 millimeter) high letters;
- 3) A 24 inch "STOP/SLOW" traffic paddle conforming to the requirements of Part 6E.03 of the Manual on Uniform Traffic Control Devices (MUTCD), a weighted, reflectorized red flag, flagger station advance warning signage, and two-way radios capable of providing clear communication within the work zone between flaggers, the Contractor, and the Engineer. The traffic paddle shall be mounted on a pole of sufficient length to be seven feet above the ground as measured from the bottom of the paddle;
- 4) A working flashlight with a minimum of 15,000 candlepower and a six inch red attachable wand, a whistle with a working lanyard, and a First Aid kit that complies with the requirements of ANSI Z308.1; and
- 5) An industrial/safety type portable air horn that complies with the requirements of the U.S. Coast Guard.

A "STOP/SLOW" paddle should be the primary hand-signaling device. It shall have an octagonal shape on a rigid handle. Flag use should be limited to emergency situations.



Properly Trained Flaggers

- Give clear messages to drivers.
- Allow distance for drivers to react.
- Coordinate with other flaggers.
- Use standard signaling methods.

Properly Equipped Flaggers

- Use approved stop/slow paddles.
- Use approved safety apparel.
- Use retroreflective equipment.
- Use hand held radios, as needed.
- All flaggers shall wear safety apparel that meets ANSI Class 3 requirements. The combination of vest and pants is required.



Proper Flagging Stations

- Good approach sight distance.
- Highly visible to traffic.
- Stand alone away from other machinery and people.
- Stand on right edge of pavement or shoulder- proceed to centerline only when first vehicle has come to stop.
- Have a good escape route.



Proper Advance Warning Signs

- Always use warning signs.
- Allow for reaction distance from signs.
- Remove signs if no longer necessary or not flagging.
- Use free hand in up-and-down motion to help slow traffic.



FIGURE 4
TYPICAL PEDESTRIAN DEVICES
(1 OF 2)
NOT TO SCALE

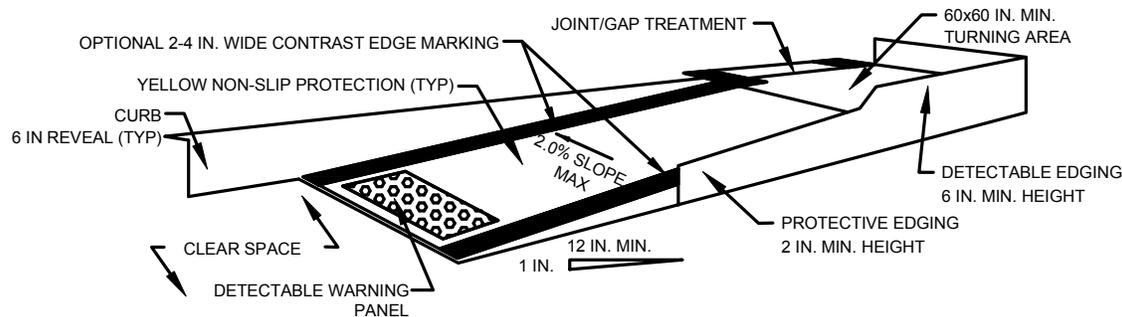

TEMPORARY CURB RAMP-PARALLEL TO CURB

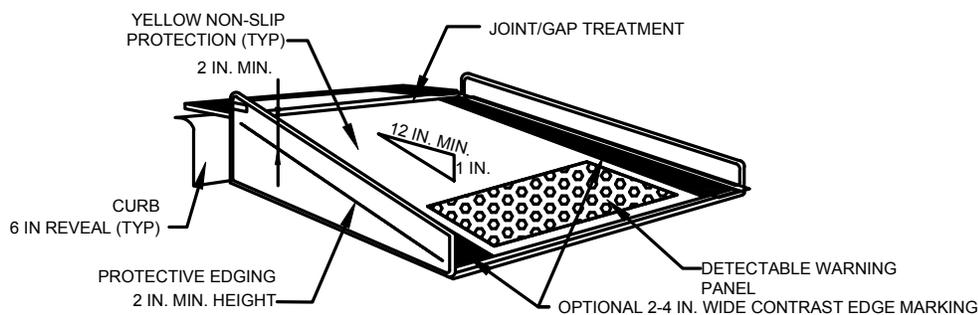

TEMPORARY CURB RAMP-PERPENDICULAR TO CURB

NOTES:

1. CURB RAMPS SHALL BE 60 IN. MINIMUM WIDTH WITH A FIRM, STABLE, AND NON-SLIP SURFACE.
2. PROTECTIVE EDGING WITH A 2 IN. MINIMUM HEIGHT SHALL BE INSTALLED WHEN THE CURB RAMP OR LANDING PLATFORM HAS A VERTICAL DROP OF 6 IN. OR GREATER OR HAS A SIDE APRON SLOPE STEEPER THAN 1:3 (33%). PROTECTIVE EDGING SHOULD BE CONSIDERED WHEN THE CURB RAMPS OR LANDING PLATFORMS HAVE A VERTICAL DROP OF 3 IN. OR MORE.
3. PROTECTABLE EDGING WITH 6 IN. MINIMUM HEIGHT AND CONTRASTING COLOR SHALL BE INSTALLED ON ALL CURB RAMP LANDINGS WHERE THE WALKWAY CHANGES DIRECTION (TURNS).
4. THE CURB RAMP WALKWAY AND LANDING AREA SURFACE SHALL BE OF A SOLID CONTINUOUS CONTRASTING COLOR ABUTTING UP TO THE EXISTING SIDEWALK.
5. CURB RAMPS AND LANDINGS SHOULD HAVE A 1:50 (2%) MAX CROSS-SLOPE.
6. CLEAR SPACE OF 48x48 IN. MINIMUM SHALL BE PROVIDED ABOVE AND BELOW THE CURB RAMP.
7. WATER FLOW IN THE GUTTER SYSTEM SHALL HAVE MINIMAL RESTRICTION.
8. LATERAL JOINTS OR GAPS BETWEEN SURFACES SHALL BE LESS THAN 0.5 IN. WIDTH.
9. CHANGES BETWEEN SURFACE HEIGHTS SHOULD NOT EXCEED 0.5 IN. LATERAL EDGES SHOULD BE VERTICAL UP TO 0.25 IN. HIGH, AND BEVELED AT 1:2 BETWEEN 0.25 IN. AND 0.5 IN. HEIGHT.
10. IF A TEMPORARY PEDESTRIAN RAMP LEADS TO A CROSSWALK, THEN A DETECTABLE WARNING PAD MUST BE ADHERED TO THE BASE OF THE RAMP. IF IT LEADS TO A PROTECTED PEDESTRIAN BYPASS THAT DOES NOT CONFLICT WITH VEHICULAR TRAFFIC, THEN A PAD SHALL NOT BE INSTALLED ON THE RAMP.

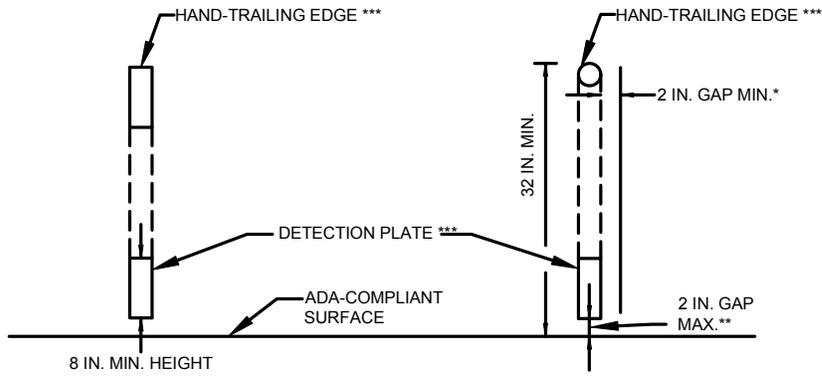

CROSS SECTION VIEW

PEDESTRIAN CHANNELIZING DEVICE

- * THERE SHALL BE A 2 INCH GAP BETWEEN THE HAND-TRAILING EDGE AND ITS SUPPORT.
- ** A MAXIMUM 2 INCH GAP BETWEEN THE BOTTOM OF THE BOTTOM RAIL AND THE SURFACE MAY BE USED TO PROVIDE DRAINAGE.
- *** THE HAND-TRAILING EDGE AND DETECTION PLATE SHALL BE CONTINUOUS THROUGHOUT THE LENGTH OF THE PATH SUCH THAT A PEDESTRIAN USER WITH A LONG CANE CAN FOLLOW IT.

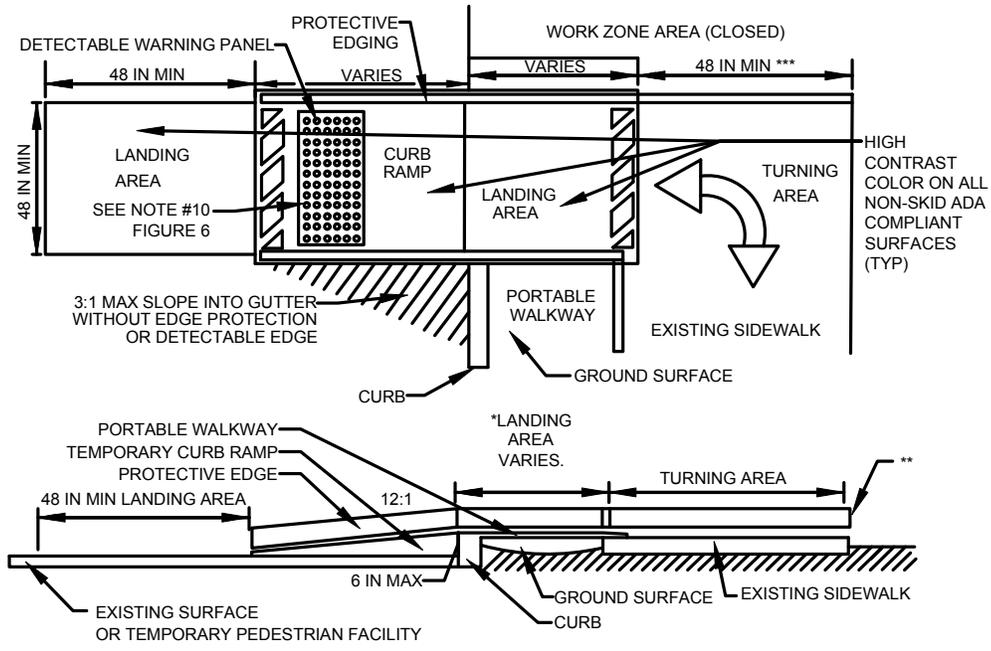

TEMPORARY CURB RAMP

- * LANDING AREA USED TO OVERLAP NON-ADA COMPLIANT SURFACES.
- ** DETECTABLE EDGE REMOVED IF A CONTINUOUS SIDEWALK.
- *** 60 IN. IF AN OBSTRUCTION IS AT BACK OF SIDEWALK.

 <p>Massachusetts Department of Transportation Highway Division</p>	<p>Work Zone Safety Standard Details and Drawings</p>	<p>FIGURE 5 TYPICAL PEDESTRIAN DEVICES (2 OF 2) NOT TO SCALE</p>
<p>PAGE 17</p>		



PAGE 18

Work Zone Safety
Standard Details
and Drawings

STATIONARY OPERATIONS
TWO LANE UNDIVIDED ROADWAY
HALF OF ROADWAY CLOSED
WORK NEAR CURVE

POSTED SPEED LIMIT (MPH)	SPACING FOR ADVANCE WARNING SIGNS (FT) (A,B,C)	CHANNELIZATION DEVICES (DRUMS OR CONES)			
		TRAVEL LANE CLOSURE LENGTH (L) (FT)	BUFFER ZONE LENGTH (FT)	DEVICE SPACING (FT)	MIN # OF DEVICES*
25-40	500 / 500 / 500	50	100	20	30
45-55	500 / 1000 / 1000	100	150	40	20

* NUMBER OF DEVICES BASED ON 400 FT WORK ZONE.

NOTES

1. IF POLICE DETAIL/UNIFORMED FLAGGER SUPPORT IS REQUIRED, PROVIDE TWO UNITS.
2. MA-R2-10a LOCATED AT C/2.
3. ** = EXTEND ENOUGH SO TAPER IS BEFORE CURVE

LEGEND

-  WORK ZONE
-  CHANNELIZATION DEVICE
-  FLASHING ARROW BOARD
-  PORTABLE CHANGEABLE MESSAGE SIGN
-  TRUCK MOUNTED ATTENUATOR
-  RADAR SPEED FEEDBACK BOARD
-  POLICE DETAIL OR UNIFORMED FLAGGER
-  TEMPORARY PORTABLE RUMBLE STRIP
-  TYPE III BARRICADE

NOT TO SCALE

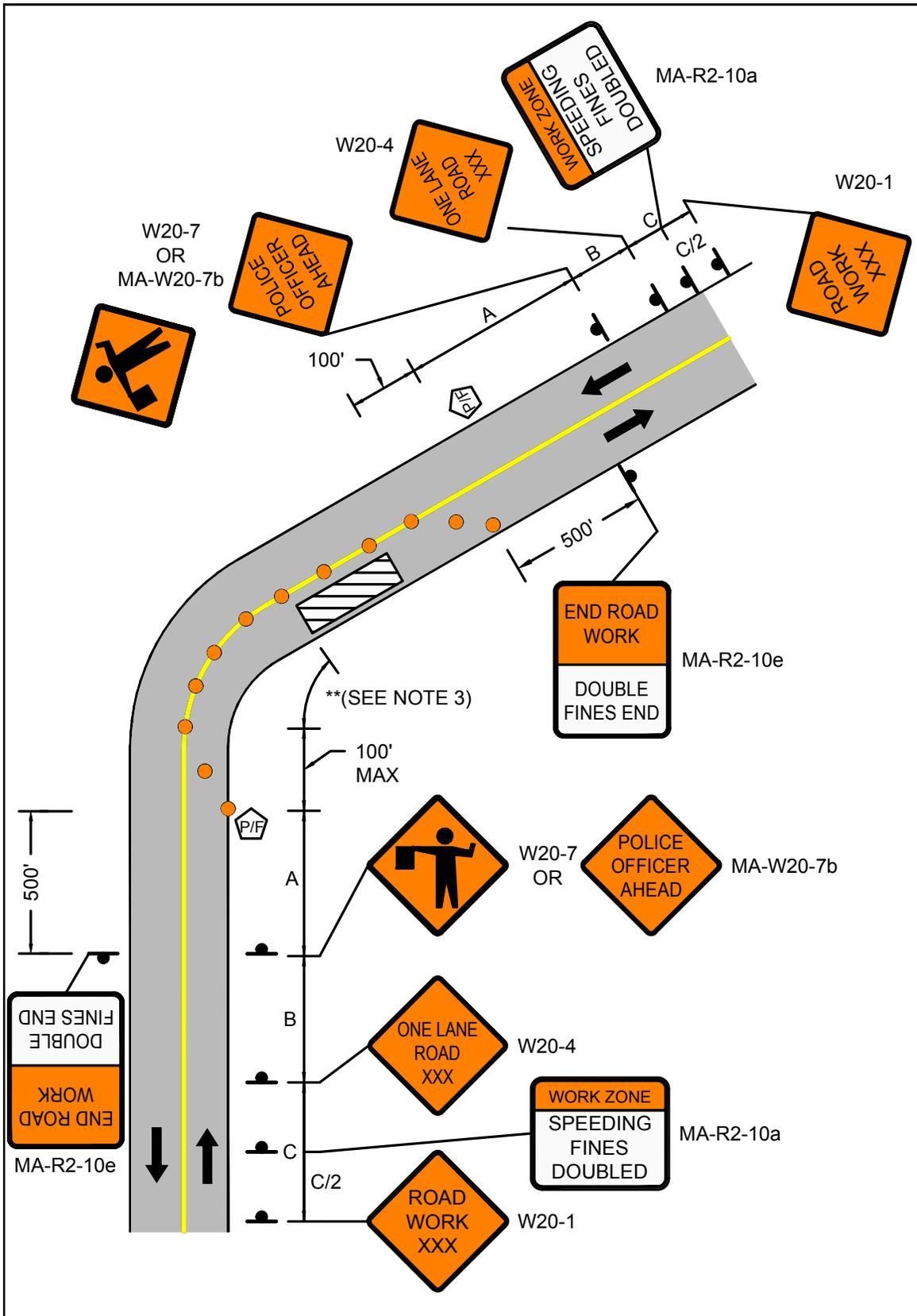

 <p>PAGE 19</p>	<p>Work Zone Safety Standard Details and Drawings</p>	<p>FIGURE 6 STATIONARY OPERATIONS TWO LANE UNDIVIDED ROADWAY HALF OF ROADWAY CLOSED WORK NEAR CURVE</p>
--	---	---



Work Zone Safety
Standard Details
and Drawings

STATIONARY OPERATIONS
TWO LANE UNDIVIDED ROADWAY
HALF OF ROADWAY CLOSED

POSTED SPEED LIMIT (MPH)	SPACING FOR ADVANCE WARNING SIGNS (FT) (A,B,C)	CHANNELIZATION DEVICES (DRUMS OR CONES)			
		TRAVEL LANE CLOSURE LENGTH (L) (FT)	BUFFER ZONE LENGTH (FT)	DEVICE SPACING (FT)	MIN # OF DEVICES*
25-40	500 / 500 / 500	50	100	20	30
45-55	500 / 1000 / 1000	100	150	40	20

* NUMBER OF DEVICES BASED ON 400 FT WORK ZONE.

POSTED REGULATORY OR WORK ZONE SPEED	SEPARATION BETWEEN RUMBLE STRIPS
36-mph to 55-mph	15-feet
35-mph and under	10-feet

NOTES

1. IF POLICE DETAIL/UNIFORMED FLAGGER SUPPORT IS REQUIRED, PROVIDE TWO UNITS.
2. MA-R2-10a LOCATED AT C/2.
3. ** OPTIONAL AT THE ENGINEER'S DISCRETION.
4. *** SHALL BE DEPLOYED IF RUMBLE STRIPS ARE PRESENT.

LEGEND

-  WORK ZONE
-  CHANNELIZATION DEVICE
-  FLASHING ARROW BOARD
-  PORTABLE CHANGEABLE MESSAGE SIGN
-  TRUCK MOUNTED ATTENUATOR
-  RADAR SPEED FEEDBACK BOARD
-  POLICE DETAIL OR UNIFORMED FLAGGER
-  TEMPORARY PORTABLE RUMBLE STRIP
-  TYPE III BARRICADE

NOT TO SCALE

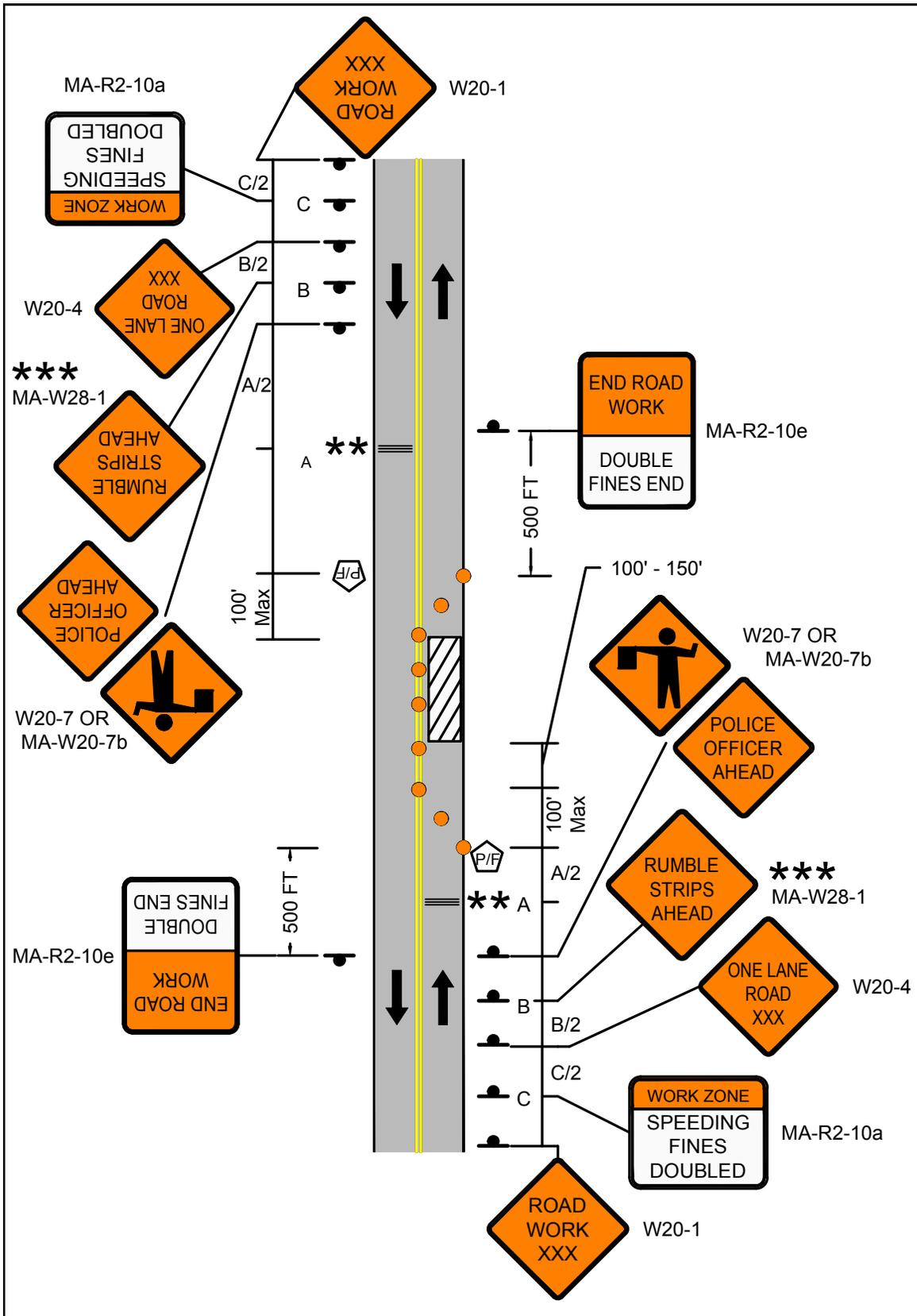

 <p>PAGE 21</p>	<p>Work Zone Safety Standard Details and Drawings</p>	<p>FIGURE 7 STATIONARY OPERATIONS TWO LANE UNDIVIDED ROADWAY HALF OF ROADWAY CLOSED</p>
--	---	---



PAGE 22

Work Zone Safety
Standard Details
and Drawings

STATIONARY OPERATIONS
TWO LANE UNDIVIDED ROADWAY
SHOULDER CLOSED

POSTED SPEED LIMIT (MPH)	SPACING FOR ADVANCE WARNING SIGNS (FT) (A,B,C)	CHANNELIZATION DEVICES (DRUMS OR CONES)			
		SHOULDER TAPER LENGTH (L/3) (FT)	BUFFER ZONE LENGTH (FT)	DEVICE SPACING (FT)	MIN # OF DEVICES*
25-40	500 / 500 / 500	110	305	20	45
45-55	500 / 1000 / 1000	220	495	40	30
60-65	1000 / 1600 / 2600	260	645	40	35

* NUMBER OF DEVICES BASED ON 400 FT WORK ZONE.

NOTES

1. MA-R2-10a at C/2 and A/2.

LEGEND

-  WORK ZONE
-  CHANNELIZATION DEVICE
-  FLASHING ARROW BOARD
-  PORTABLE CHANGEABLE MESSAGE SIGN
-  TRUCK MOUNTED ATTENUATOR
-  RADAR SPEED FEEDBACK BOARD
-  POLICE DETAIL OR UNIFORMED FLAGGER
-  TEMPORARY PORTABLE RUMBLE STRIP
-  TYPE III BARRICADE

NOT TO SCALE

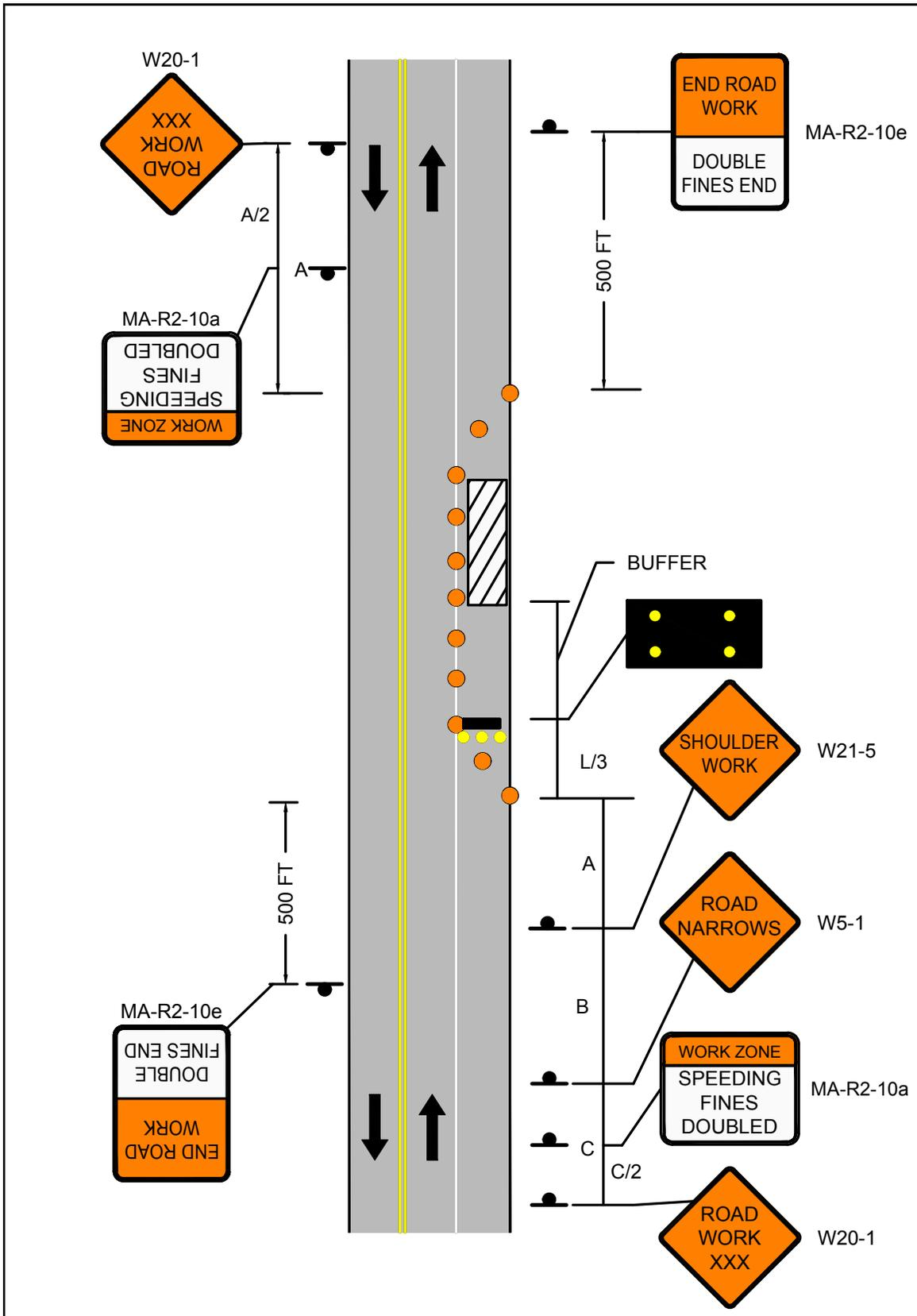

 <p>PAGE 23</p>	<p>Work Zone Safety Standard Details and Drawings</p>	<p>FIGURE 8 STATIONARY OPERATIONS TWO LANE UNDIVIDED ROADWAY SHOULDER CLOSED</p>
--	---	--



PAGE 24

Work Zone Safety
Standard Details
and Drawings

STATIONARY OPERATIONS
TWO LANE UNDIVIDED ROADWAY
WITH TRAVERSABLE SHOULDER
HALF OF ROADWAY CLOSED
MAINTAIN TWO-WAY TRAFFIC

POSTED SPEED LIMIT (MPH)	CHANNELIZATION DEVICES (DRUMS OR CONES)				
	SHOULDER TAPER LENGTH (L/3) (FT)	TRAVEL LANE SHIFT LENGTH (L/2) (FT)	BUFFER ZONE LENGTH (FT)	DEVICE SPACING (FT)	MIN # OF DEVICES*
25-40	110	160	305	20	125
45-55	220	330	495	40	100
60-65	260	390	645	40	115

* NUMBER OF DEVICES BASED ON 400 FT WORK ZONE.

POSTED SPEED LIMIT (MPH)	SPACING FOR ADVANCE WARNING SIGNS (FT) (A,B,C)
25-40	500 / 500 / 500
45-55	500 / 1000 / 1000
60-65	1000 / 1600 / 2600

NOTES

1. MA-R2-10a LOCATED AT C/2.

LEGEND

-  WORK ZONE
-  CHANNELIZATION DEVICE
-  FLASHING ARROW BOARD
-  PORTABLE CHANGEABLE MESSAGE SIGN
-  TRUCK MOUNTED ATTENUATOR
-  RADAR SPEED FEEDBACK BOARD
-  POLICE DETAIL OR UNIFORMED FLAGGER
-  TEMPORARY PORTABLE RUMBLE STRIP
-  TYPE III BARRICADE

NOT TO SCALE

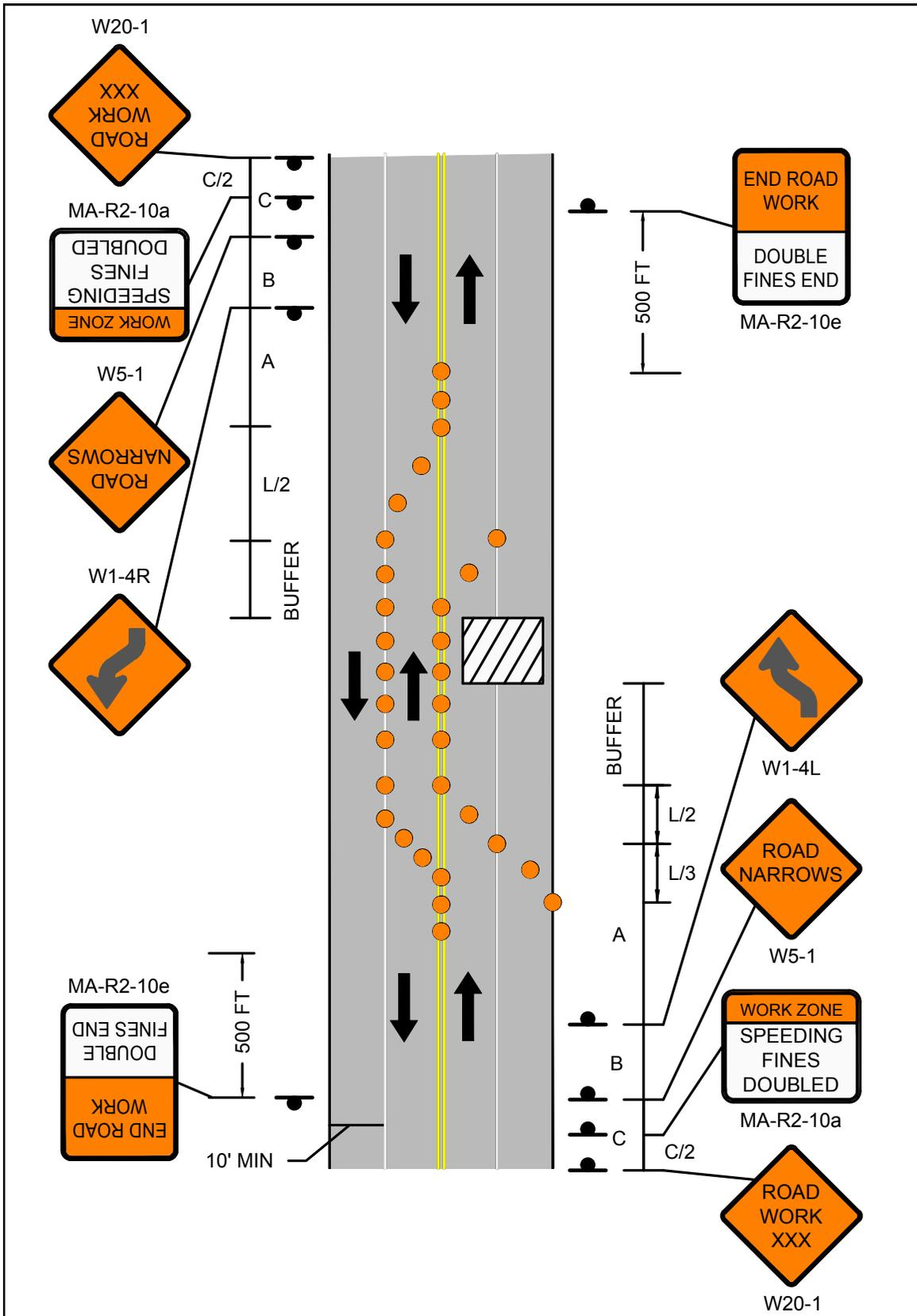

FIGURE 9
STATIONARY OPERATIONS
TWO LANE UNDIVIDED ROADWAY
WITH TRAVERSABLE SHOULDER
HALF OF ROADWAY CLOSED
MAINTAIN TWO-WAY TRAFFIC





PAGE 26

Work Zone Safety
Standard Details
and Drawings

STATIONARY OPERATIONS
FOUR LANE UNDIVIDED ROADWAY
RIGHT LANE CLOSED

POSTED SPEED LIMIT (MPH)	CHANNELATION DEVICES (DRUMS OR CONES)				
	SHOULDER TAPER LENGTH (L/3) (FT)	TRAVEL LANE CLOSURE LENGTH (L) (FT)	BUFFER ZONE LENGTH (FT)	DEVICE SPACING (FT)	MIN # OF DEVICES*
25-40	110	320	305	20	60
45-55	220	660	495	40	50
60-65	260	780	645	40	55

* NUMBER OF DEVICES BASED ON 400 FT WORK ZONE.

POSTED SPEED LIMIT (MPH)	SPACING FOR ADVANCE WARNING SIGNS (FT) (A,B,C)
25-40	500 / 500 / 500
45-55	500 / 1000 / 1000
60-65	1000 / 1600 / 2600

NOTES

1. MA-R2-10a LOCATED AT A/2 AND C/2.
2. **OPTIONAL AT THE ENGINEER'S DISCRETION.

LEGEND

-  WORK ZONE
-  CHANNELIZATION DEVICE
-  FLASHING ARROW BOARD
-  PORTABLE CHANGEABLE MESSAGE SIGN
-  TRUCK MOUNTED ATTENUATOR
-  RADAR SPEED FEEDBACK BOARD
-  POLICE DETAIL OR UNIFORMED FLAGGER
-  TEMPORARY PORTABLE RUMBLE STRIP
-  TYPE III BARRICADE

NOT TO SCALE

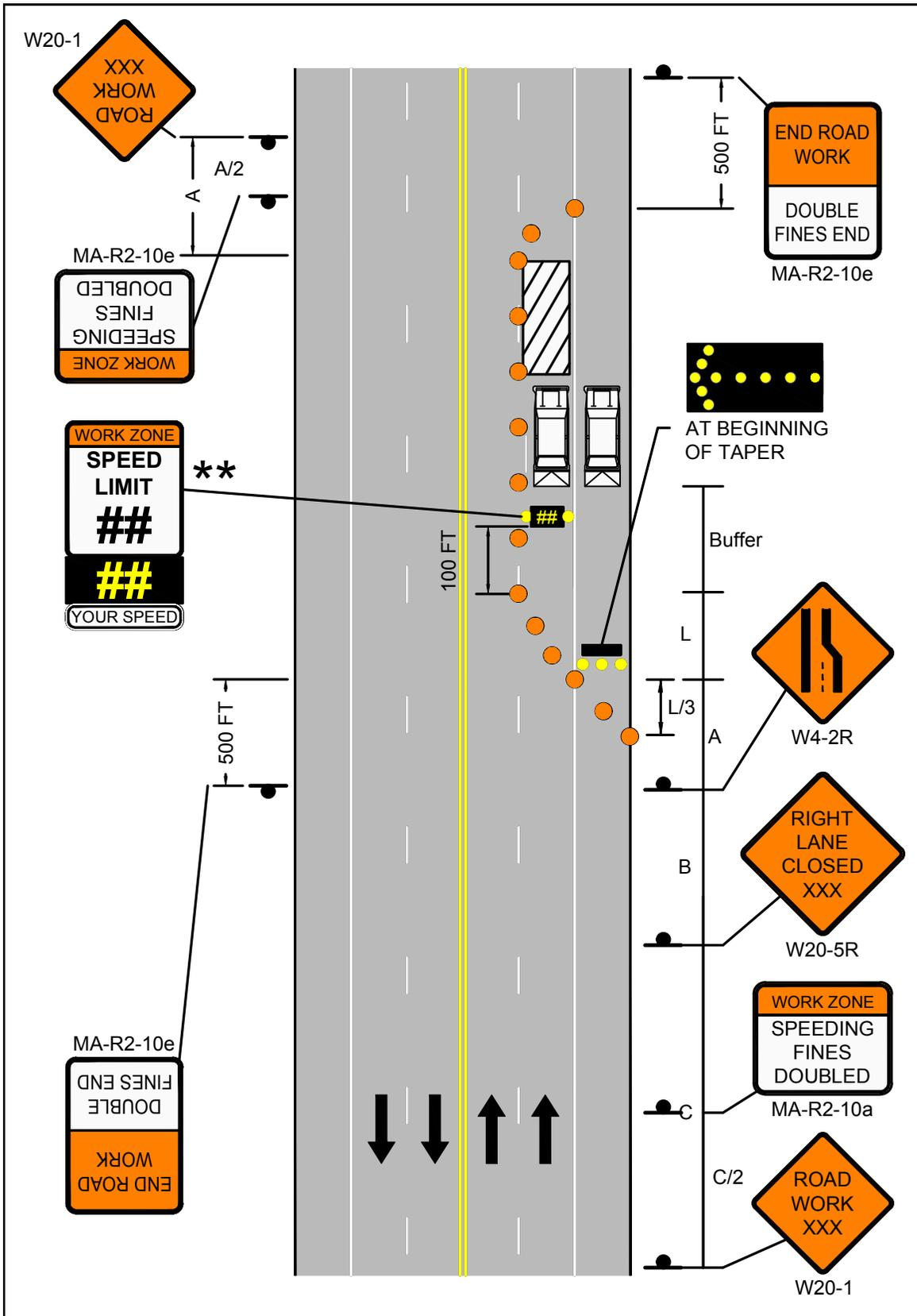

 <p>PAGE 27</p>	<p>Work Zone Safety Standard Details and Drawings</p>	<p>FIGURE 10 STATIONARY OPERATIONS FOUR LANE UNDIVIDED ROADWAY RIGHT LANE CLOSED</p>
--	---	--



PAGE 28

Work Zone Safety
Standard Details
and Drawings

STATIONARY OPERATIONS
FOUR LANE UNDIVIDED ROADWAY
LEFT LANE CLOSED

POSTED SPEED LIMIT (MPH)	SPACING FOR ADVANCE WARNING SIGNS (FT) (A,B,C)	CHANNELIZATION DEVICES (DRUMS OR CONES)			
		TRAVEL LANE CLOSURE LENGTH (L) (FT)	BUFFER ZONE LENGTH (FT)	DEVICE SPACING (FT)	MIN # OF DEVICES*
25-40	500 / 500 / 500	320	305	20	105
45-55	500 / 1000 / 1000	660	495	40	80
60-65	1000 / 1600 / 2600	780	645	40	100

* NUMBER OF DEVICES BASED ON 400 FT WORK ZONE.

NOTES

1. MA-R2-10a LOCATED AT A/2 AND C/2.
2. **OPTIONAL AT THE ENGINEER'S DISCRETION. 2' OFFSET FROM EDGE OF TRAVEL LANE TO RADAR SPEED FEEDBACK BOARD IS REQUIRED. BOARD MAY BE MOVED FULLY OR PARTIALLY OFF PAVED SHOULDER, IF REQUIRED.

LEGEND

-  WORK ZONE
-  CHANNELIZATION DEVICE
-  FLASHING ARROW BOARD
-  PORTABLE CHANGEABLE MESSAGE SIGN
-  TRUCK MOUNTED ATTENUATOR
-  RADAR SPEED FEEDBACK BOARD
-  POLICE DETAIL OR UNIFORMED FLAGGER
-  TEMPORARY PORTABLE RUMBLE STRIP
-  TYPE III BARRICADE

NOT TO SCALE

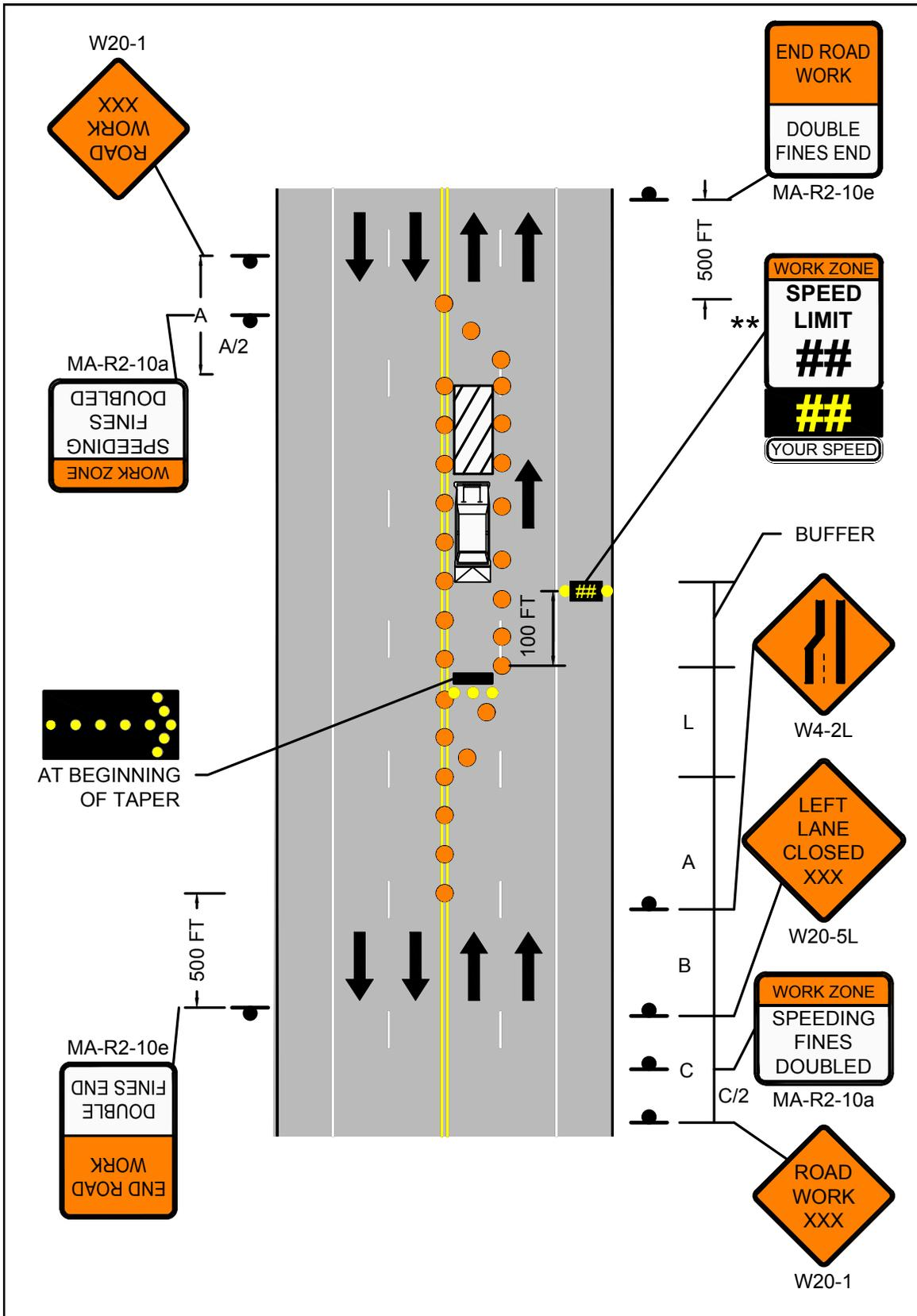

FIGURE 11
STATIONARY OPERATIONS
FOUR LANE UNDIVIDED ROADWAY
LEFT LANE CLOSED



 PAGE 30	Work Zone Safety Standard Details and Drawings	STATIONARY OPERATIONS FOUR LANE UNDIVIDED ROADWAY HALF OF ROADWAY CLOSED
--	--	--

POSTED SPEED LIMIT (MPH)	CHANNELIZATION DEVICES (DRUMS OR CONES)					
	SHOULDER TAPER LENGTH (L/3) (FT)	TRAVEL LANE CLOSURE LENGTH (L) (FT)	TRAVEL LANE SHIFT LENGTH (L/2) (FT)	BUFFER ZONE LENGTH (FT)	DEVICE SPACING (FT)	MIN # OF DEVICES*
25-40	110	320	160	305	20	140
45-55	220	660	330	495	40	120
60-65	260	780	390	645	40	140

* NUMBER OF DEVICES BASED ON 400 FT WORK ZONE.

POSTED SPEED LIMIT (MPH)	SPACING FOR ADVANCE WARNING SIGNS (FT) (A,B,C)
25-40	500 / 500 / 500
45-55	500 / 1000 / 1000
60-65	1000 / 1600 / 2600

NOTES

1. MA-R2-10a LOCATED AT C/2.
2. **OPTIONAL AT THE ENGINEER'S DISCRETION.
3. W1-4L SHALL BE PLACED AT THE MIDDLE OF THE TANGENT.

LEGEND

-  WORK ZONE
-  CHANNELIZATION DEVICE
-  FLASHING ARROW BOARD
-  PORTABLE CHANGEABLE MESSAGE SIGN
-  TRUCK MOUNTED ATTENUATOR
-  RADAR SPEED FEEDBACK BOARD
-  POLICE DETAIL OR UNIFORMED FLAGGER
-  TEMPORARY PORTABLE RUMBLE STRIP
-  TYPE III BARRICADE

NOT TO SCALE

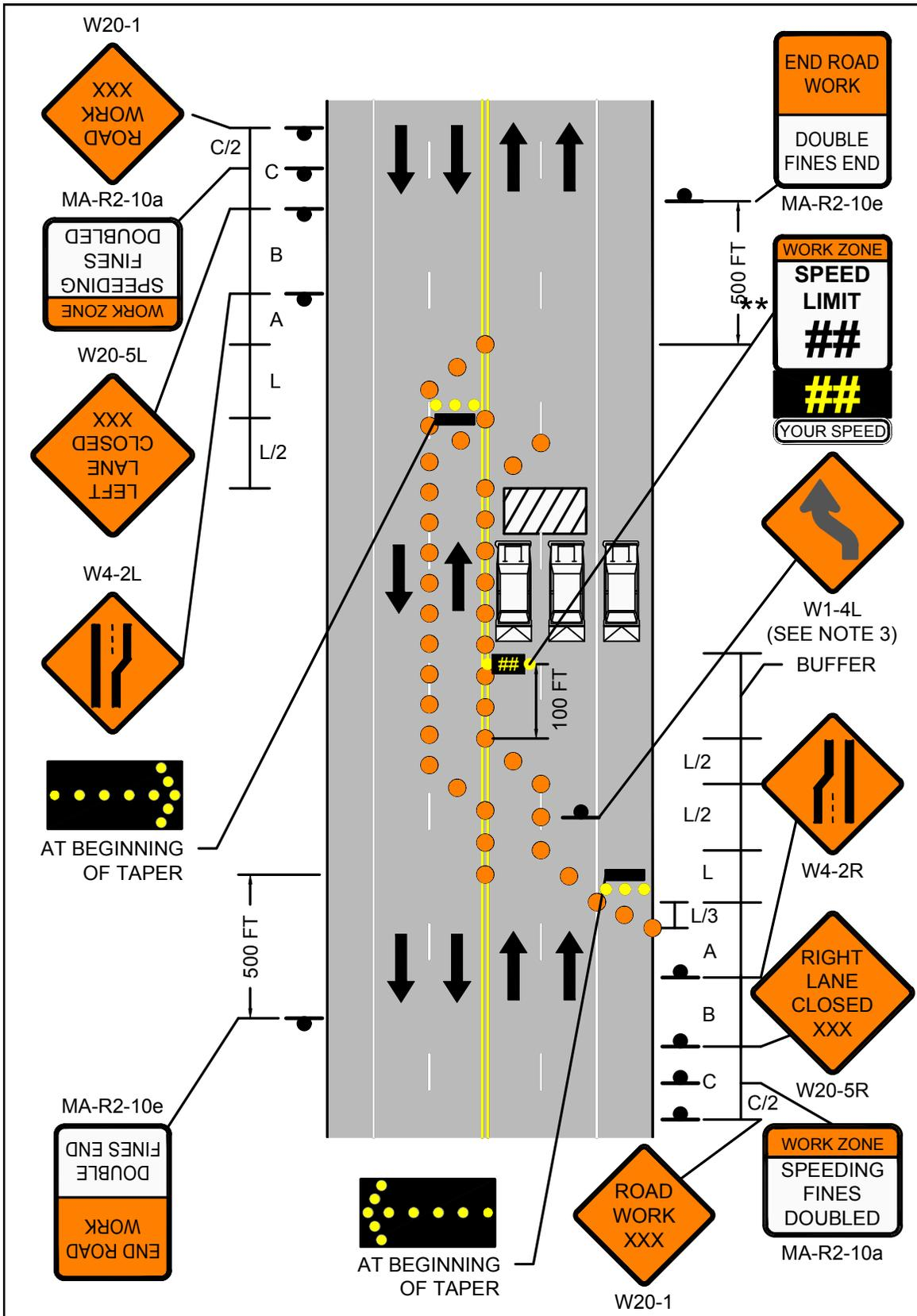

 <p>PAGE 31</p>	<p>Work Zone Safety Standard Details and Drawings</p>	<p>FIGURE 12 STATIONARY OPERATIONS FOUR LANE UNDIVIDED ROADWAY HALF OF ROADWAY CLOSED</p>
--	---	---



PAGE 32

Work Zone Safety
Standard Details
and Drawings

STATIONARY OPERATIONS
MULTILANE DIVIDED ROADWAY
RIGHT LANE CLOSED

POSTED SPEED LIMIT (MPH)	CHANNELIZATION DEVICES (DRUMS OR CONES)				
	SHOULDER TAPER LENGTH (L/3) (FT)	TRAVEL LANE CLOSURE LENGTH (L) (FT)	BUFFER ZONE LENGTH (FT)	DEVICE SPACING (FT)	MIN # OF DEVICES*
25-40	110	320	305	20	60
45-55	220	660	495	40	50
60-65	260	780	645	40	55

* NUMBER OF DEVICES BASED ON 400 FT WORK ZONE.

POSTED SPEED LIMIT (MPH)	SPACING FOR ADVANCE WARNING SIGNS (FT) (A,B,C)
25-40	500 / 500 / 500
45-55	500 / 1000 / 1000
60-65	1000 / 1600 / 2600

NOTES

1. MA-R2-10a LOCATED AT C/2.
2. **OPTIONAL AT THE ENGINEER'S DISCRETION.

LEGEND

-  WORK ZONE
-  CHANNELIZATION DEVICE
-  FLASHING ARROW BOARD
-  PORTABLE CHANGEABLE MESSAGE SIGN
-  TRUCK MOUNTED ATTENUATOR
-  RADAR SPEED FEEDBACK BOARD
-  POLICE DETAIL OR UNIFORMED FLAGGER
-  TEMPORARY PORTABLE RUMBLE STRIP
-  TYPE III BARRICADE

NOT TO SCALE



PAGE 34

Work Zone Safety
Standard Details
and Drawings

STATIONARY OPERATIONS
MULTILANE DIVIDED ROADWAY
LEFT LANE CLOSED

POSTED SPEED LIMIT (MPH)	CHANNELIZATION DEVICES (DRUMS OR CONES)				
	SHOULDER TAPER LENGTH (L/3) (FT)	TRAVEL LANE CLOSURE LENGTH (L) (FT)	BUFFER ZONE LENGTH (FT)	DEVICE SPACING (FT)	MIN # OF DEVICES*
25-40	110	320	305	20	60
45-55	220	660	495	40	50
60-65	260	780	645	40	55

* NUMBER OF DEVICES BASED ON 400 FT WORK ZONE.

POSTED SPEED LIMIT (MPH)	SPACING FOR ADVANCE WARNING SIGNS (FT) (A,B,C)
25-40	500 / 500 / 500
45-55	500 / 1000 / 1000
60-65	1000 / 1600 / 2600

NOTES

1. MA-R2-10a LOCATED AT C/2.
2. **OPTIONAL AT THE ENGINEER'S DISCRETION.

LEGEND

-  WORK ZONE
-  CHANNELIZATION DEVICE
-  FLASHING ARROW BOARD
-  PORTABLE CHANGEABLE MESSAGE SIGN
-  TRUCK MOUNTED ATTENUATOR
-  RADAR SPEED FEEDBACK BOARD
-  POLICE DETAIL OR UNIFORMED FLAGGER
-  TEMPORARY PORTABLE RUMBLE STRIP
-  TYPE III BARRICADE

NOT TO SCALE

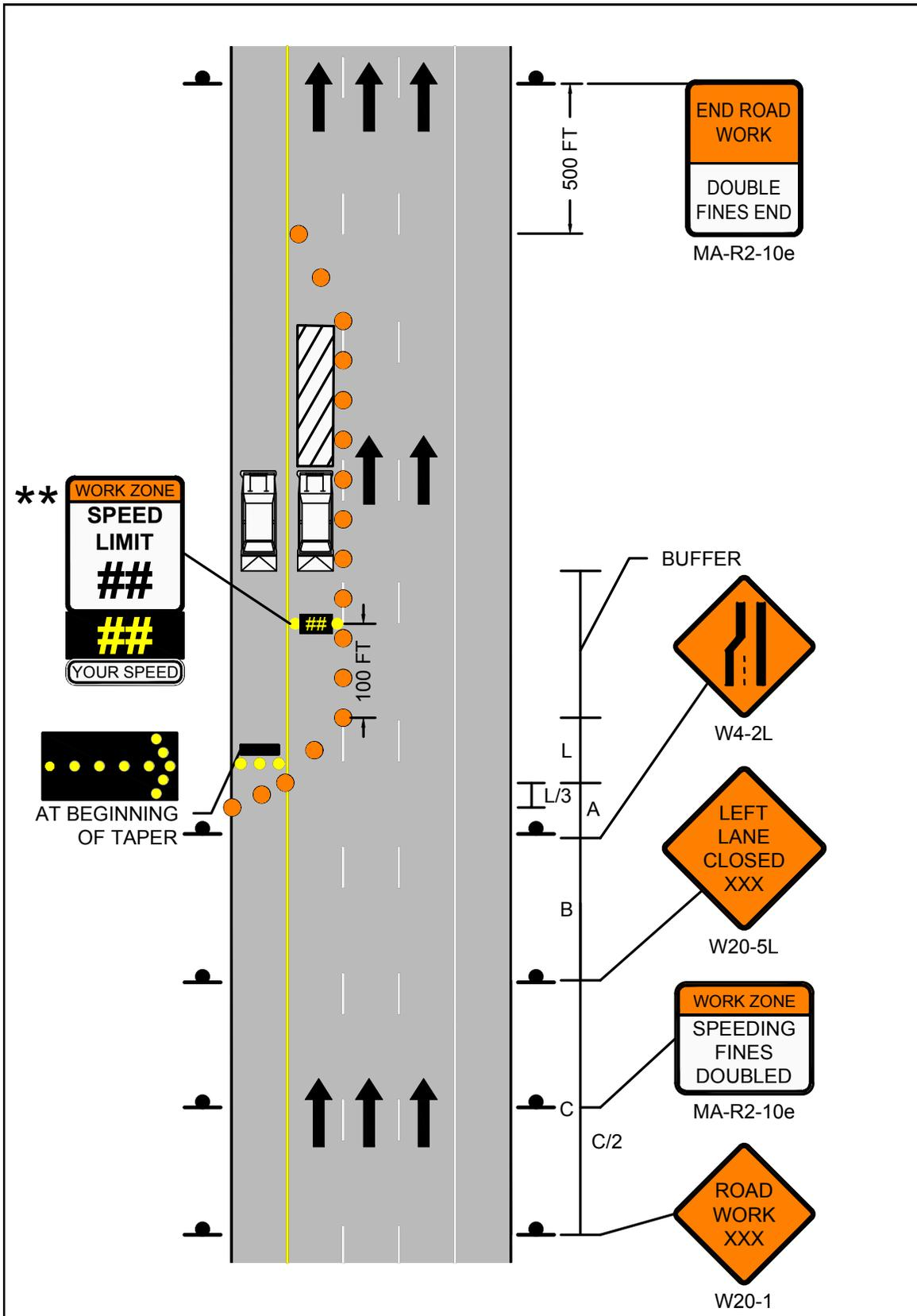

 PAGE 36	Work Zone Safety Standard Details and Drawings	STATIONARY OPERATIONS MULTILANE DIVIDED ROADWAY CENTER LANE OR RIGHT/CENTER LANES CLOSED
--	--	---

POSTED SPEED LIMIT (MPH)	CHANNELIZATION DEVICES (DRUMS OR CONES)					
	SHOULDER TAPER LENGTH (L/3) (FT)	TRAVEL LANE CLOSURE LENGTH (L) (FT)	TANGENT LENGTH BETWEEN TAPERS T (FT)	BUFFER ZONE LENGTH (FT)	DEVICE SPACING (FT)	MIN # OF DEVICES*
25-40	110	320	640	305	20	110
45-55	220	660	1320	495	40	100
60-65	260	780	1560	645	40	115

* NUMBER OF DEVICES BASED ON 400 FT WORK ZONE.

POSTED SPEED LIMIT (MPH)	SPACING FOR ADVANCE WARNING SIGNS (FT) (A,B,C)
25-40	500 / 500 / 500
45-55	500 / 1000 / 1000
60-65	1000 / 1600 / 2600

NOTES

1. MA-R2-10a LOCATED AT C/2.
2. ***OPTIONAL AT THE ENGINEER'S DISCRETION.
3. ***THIS SET OF SIGNS SHALL BE LOCATED AT T/2.

LEGEND

-  WORK ZONE
-  CHANNELIZATION DEVICE
-  FLASHING ARROW BOARD
-  PORTABLE CHANGEABLE MESSAGE SIGN
-  TRUCK MOUNTED ATTENUATOR
-  RADAR SPEED FEEDBACK BOARD
-  POLICE DETAIL OR UNIFORMED FLAGGER
-  TEMPORARY PORTABLE RUMBLE STRIP
-  TYPE III BARRICADE

NOT TO SCALE

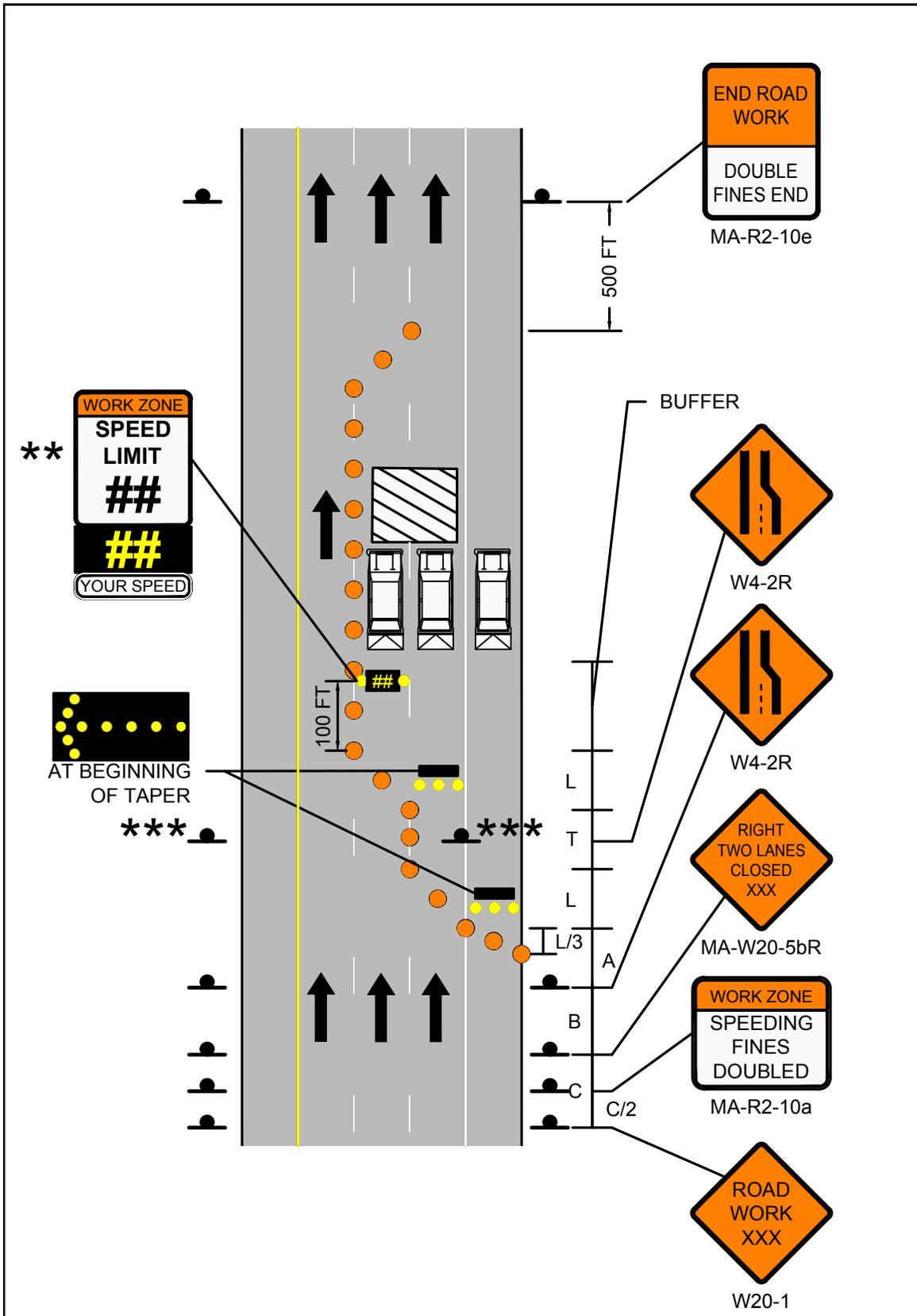

FIGURE 15
STATIONARY OPERATIONS
MULTILANE DIVIDED ROADWAY
CENTER LANE OR RIGHT/CENTER
LANES CLOSED



 <p>PAGE 38</p>	<p>Work Zone Safety Standard Details and Drawings</p>	<p>STATIONARY OPERATIONS MULTILANE DIVIDED ROADWAY CENTER LANE OR LEFT/CENTER LANES CLOSED</p>
--	---	--

POSTED SPEED LIMIT (MPH)	CHANNELIZATION DEVICES (DRUMS OR CONES)					
	SHOULDER TAPER LENGTH (L/3) (FT)	TRAVEL LANE CLOSURE LENGTH (L) (FT)	TANGENT LENGTH BETWEEN TAPERS T (FT)	BUFFER ZONE LENGTH (FT)	DEVICE SPACING (FT)	MIN # OF DEVICES*
25-40	110	320	640	305	20	110
45-55	220	660	1320	495	40	100
60-65	260	780	1560	645	40	115

* NUMBER OF DEVICES BASED ON 400 FT WORK ZONE.

POSTED SPEED LIMIT (MPH)	SPACING FOR ADVANCE WARNING SIGNS (FT) (A,B,C)
25-40	500 / 500 / 500
45-55	500 / 1000 / 1000
60-65	1000 / 1600 / 2600

NOTES

1. MA-R2-10a LOCATED AT C/2.
2. ***OPTIONAL AT THE ENGINEER'S DISCRETION.
3. ***THIS SET OF SIGNS SHALL BE LOCATED AT T/2.

LEGEND

-  WORK ZONE
-  CHANNELIZATION DEVICE
-  FLASHING ARROW BOARD
-  PORTABLE CHANGEABLE MESSAGE SIGN
-  TRUCK MOUNTED ATTENUATOR
-  RADAR SPEED FEEDBACK BOARD
-  POLICE DETAIL OR UNIFORMED FLAGGER
-  TEMPORARY PORTABLE RUMBLE STRIP
-  TYPE III BARRICADE

NOT TO SCALE

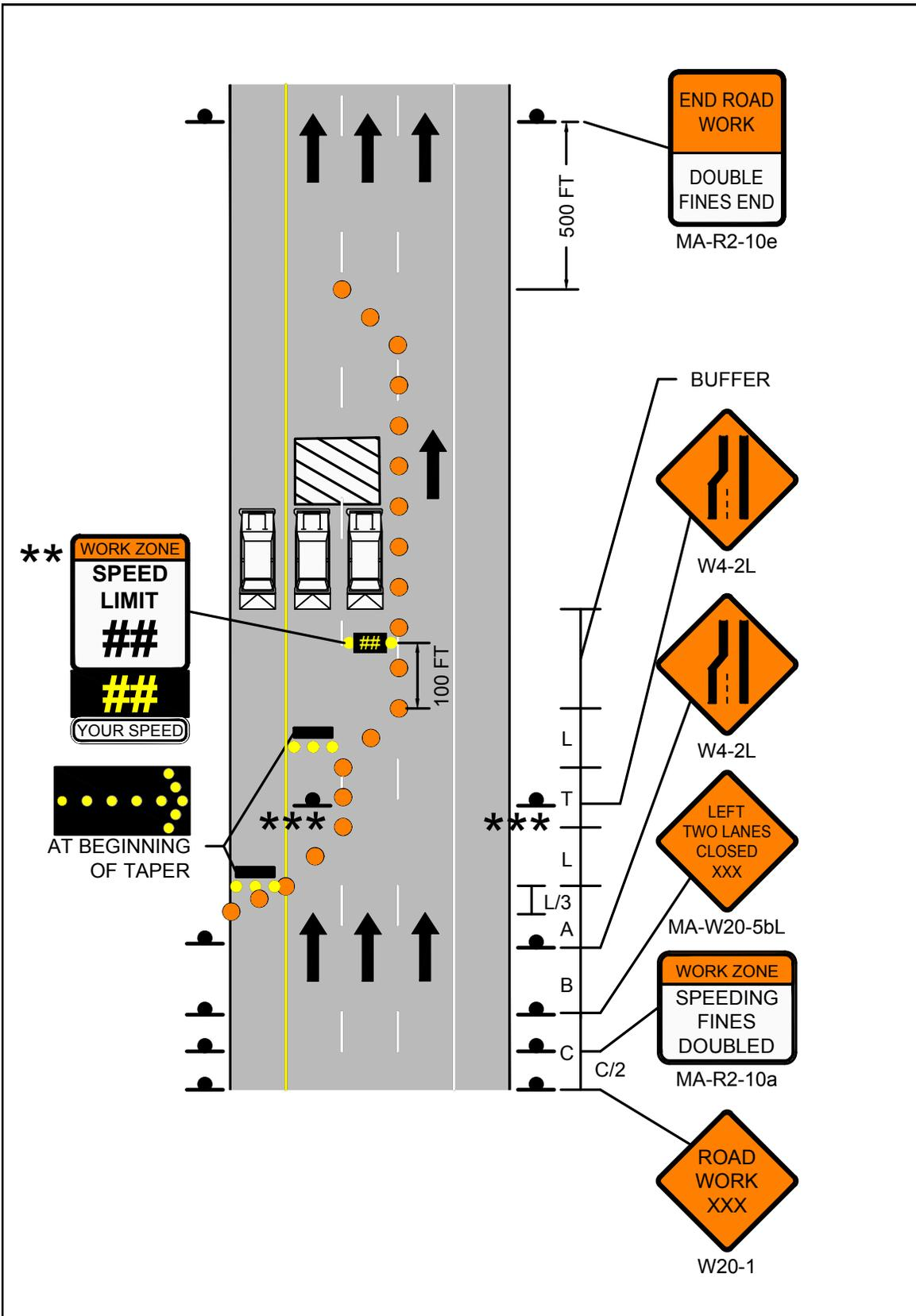

 <p>PAGE 39</p>	<p>Work Zone Safety Standard Details and Drawings</p>	<p>FIGURE 16 STATIONARY OPERATIONS MULTILANE DIVIDED ROADWAY CENTER LANE OR LEFT/CENTER LANES CLOSED</p>
--	---	--



PAGE 40

Work Zone Safety
Standard Details
and Drawings

STATIONARY OPERATIONS
MULTILANE DIVIDED ROADWAY
RIGHT SIDE OF OFF RAMP CLOSED

POSTED SPEED LIMIT (MPH)	SPACING FOR ADVANCE WARNING SIGNS (FT) (A,B,C)	CHANNELIZATION DEVICES (DRUMS OR CONES)			
		TRAVEL LANE SHIFT LENGTH (L/2) (FT)	BUFFER ZONE LENGTH (FT)	DEVICE SPACING (FT)	MIN # OF DEVICES*
25-40	500 / 500 / 500	160	305	20	45
45-55	500 / 1000 / 1000	330	495	40	35

* NUMBER OF DEVICES BASED ON 400 FT WORK ZONE.

NOTES

1. MA-R2-10a LOCATED AT C/2.

LEGEND

-  WORK ZONE
-  CHANNELIZATION DEVICE
-  FLASHING ARROW BOARD
-  PORTABLE CHANGEABLE MESSAGE SIGN
-  TRUCK MOUNTED ATTENUATOR
-  RADAR SPEED FEEDBACK BOARD
-  POLICE DETAIL OR UNIFORMED FLAGGER
-  TEMPORARY PORTABLE RUMBLE STRIP
-  TYPE III BARRICADE

NOT TO SCALE

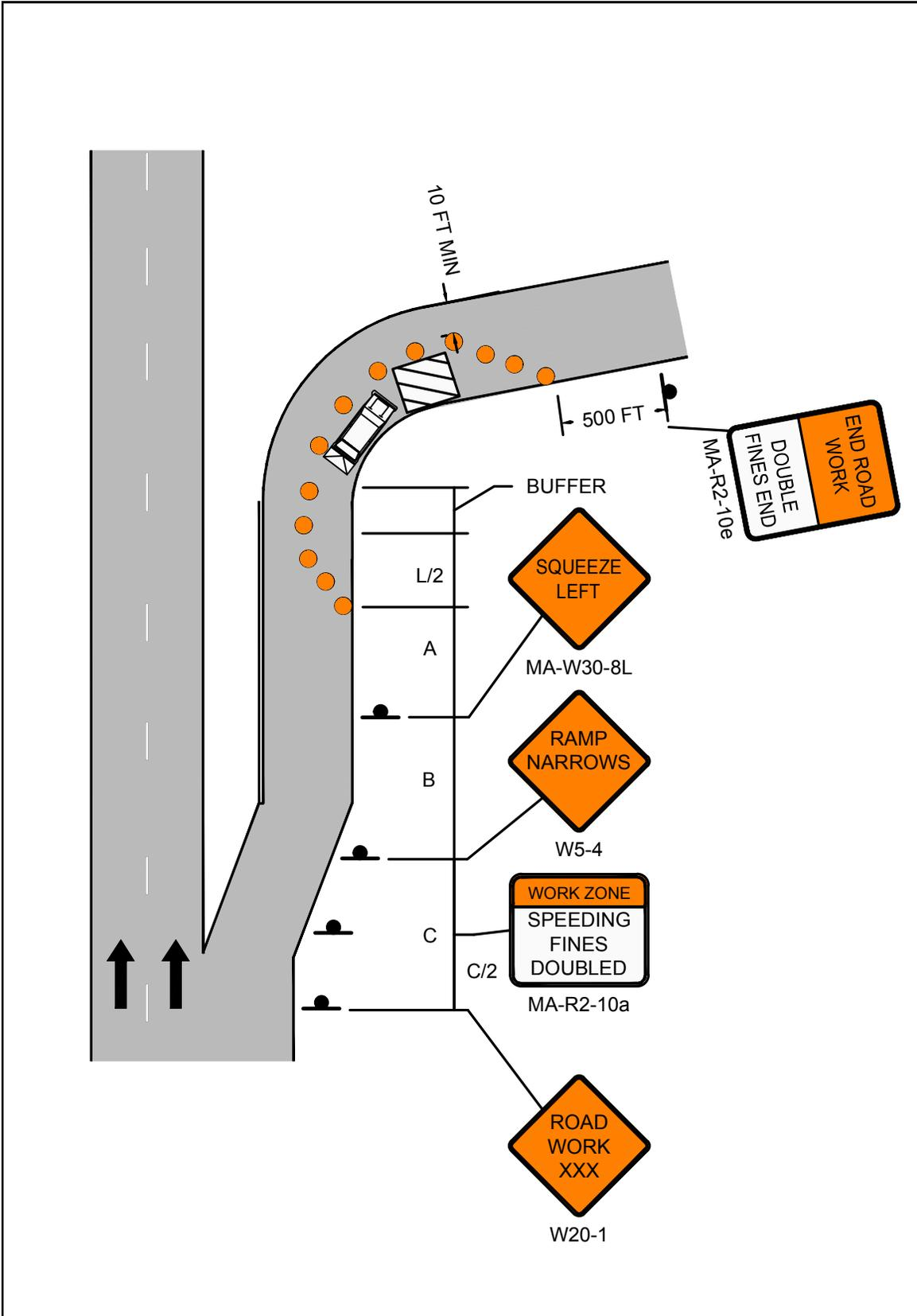

 <p>Massachusetts Department of Transportation Highway Division</p> <p>PAGE 41</p>	<p>Work Zone Safety Standard Details and Drawings</p>	<p>FIGURE 17 STATIONARY OPERATIONS MULTILANE DIVIDED ROADWAY RIGHT SIDE OF OFF RAMP CLOSED</p>
---	---	--



PAGE 42

Work Zone Safety
Standard Details
and Drawings

STATIONARY OPERATIONS
MULTILANE DIVIDED ROADWAY
LEFT SIDE OF OFF RAMP CLOSED

POSTED SPEED LIMIT (MPH)	SPACING FOR ADVANCE WARNING SIGNS (FT) (A,B,C)	CHANNELIZATION DEVICES (DRUMS OR CONES)			
		TRAVEL LANE SHIFT LENGTH (L/2) (FT)	BUFFER ZONE LENGTH (FT)	DEVICE SPACING (FT)	MIN # OF DEVICES*
25-40	500 / 500 / 500	160	305	20	45
45-55	500 / 1000 / 1000	330	495	40	35

* NUMBER OF DEVICES BASED ON 400 FT WORK ZONE.

NOTES

1. MA-R2-10a LOCATED AT C/2.

LEGEND

-  WORK ZONE
-  CHANNELIZATION DEVICE
-  FLASHING ARROW BOARD
-  PORTABLE CHANGEABLE MESSAGE SIGN
-  TRUCK MOUNTED ATTENUATOR
-  RADAR SPEED FEEDBACK BOARD
-  POLICE DETAIL OR UNIFORMED FLAGGER
-  TEMPORARY PORTABLE RUMBLE STRIP
-  TYPE III BARRICADE

NOT TO SCALE

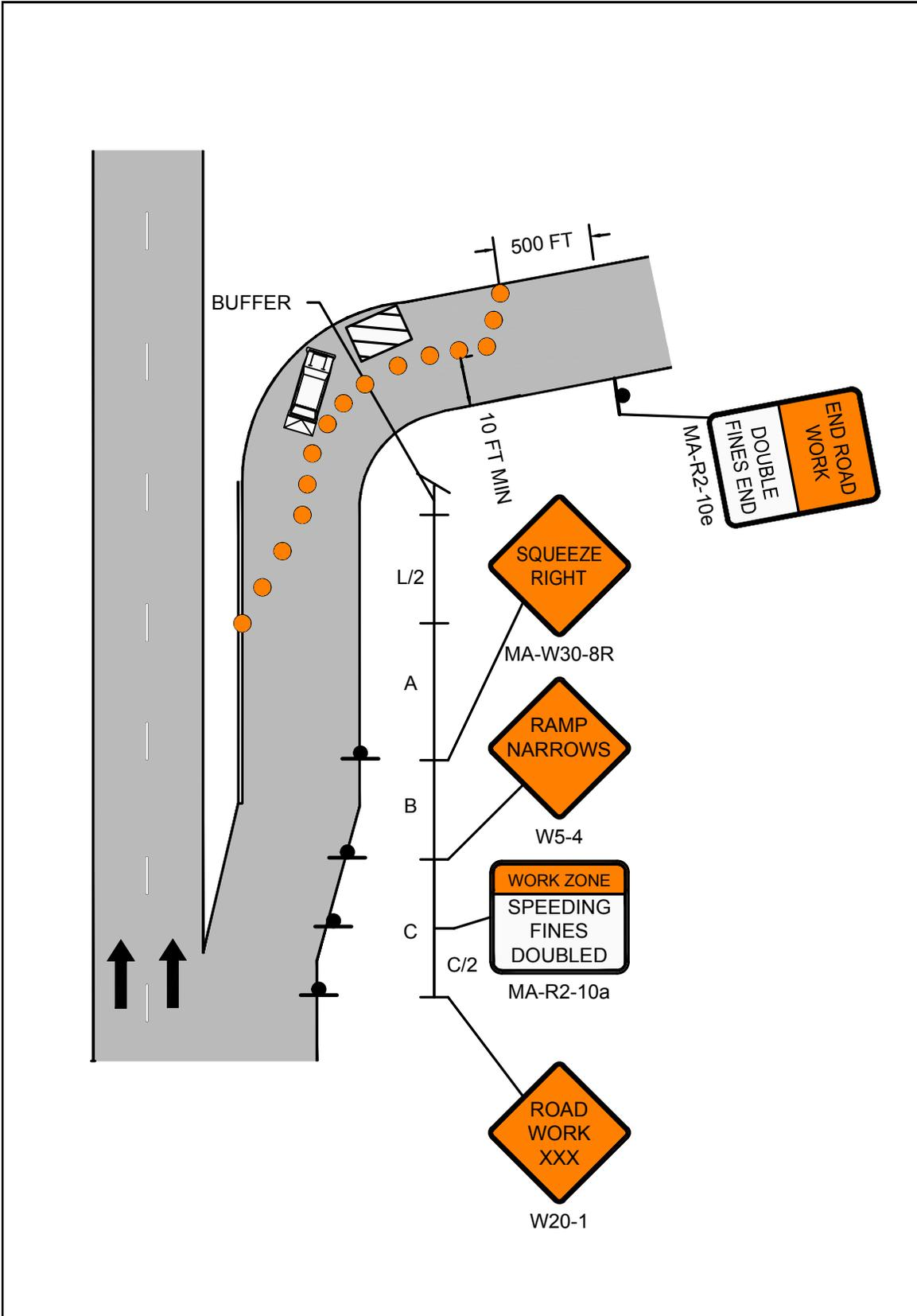

	<p>Work Zone Safety Standard Details and Drawings</p>	<p>FIGURE 18 STATIONARY OPERATIONS MULTILANE DIVIDED ROADWAY LEFT SIDE OF OFF RAMP CLOSED PAGE 43</p>
---	---	---



PAGE 44

Work Zone Safety
Standard Details
and Drawings

STATIONARY OPERATIONS
MULTILANE DIVIDED ROADWAY
ROADWORK BEYOND ON RAMP

POSTED SPEED LIMIT (MPH)	CHANNELIZATION DEVICES (DRUMS OR CONES)				
	SHOULDER TAPER LENGTH (L/3) (FT)	TRAVEL LANE CLOSURE LENGTH (L) (FT)	BUFFER ZONE LENGTH (FT)	DEVICE SPACING (FT)	MIN # OF DEVICES*
25-40	110	320	305	20	175
45-55	220	660	495	40	135
60-65	260	780	645	40	155

* NUMBER OF DEVICES BASED ON 400 FT WORK ZONE.

POSTED SPEED LIMIT (MPH)	SPACING FOR ADVANCE WARNING SIGNS (FT) (A,B,C)
25-40	500 / 500 / 500
45-55	500 / 1000 / 1000
60-65	1000 / 1600 / 2600

NOTES

1. MA-R2-10a LOCATED AT C/2.

LEGEND

-  WORK ZONE
-  CHANNELIZATION DEVICE
-  FLASHING ARROW BOARD
-  PORTABLE CHANGEABLE MESSAGE SIGN
-  TRUCK MOUNTED ATTENUATOR
-  RADAR SPEED FEEDBACK BOARD
-  POLICE DETAIL OR UNIFORMED FLAGGER
-  TEMPORARY PORTABLE RUMBLE STRIP
-  TYPE III BARRICADE

NOT TO SCALE

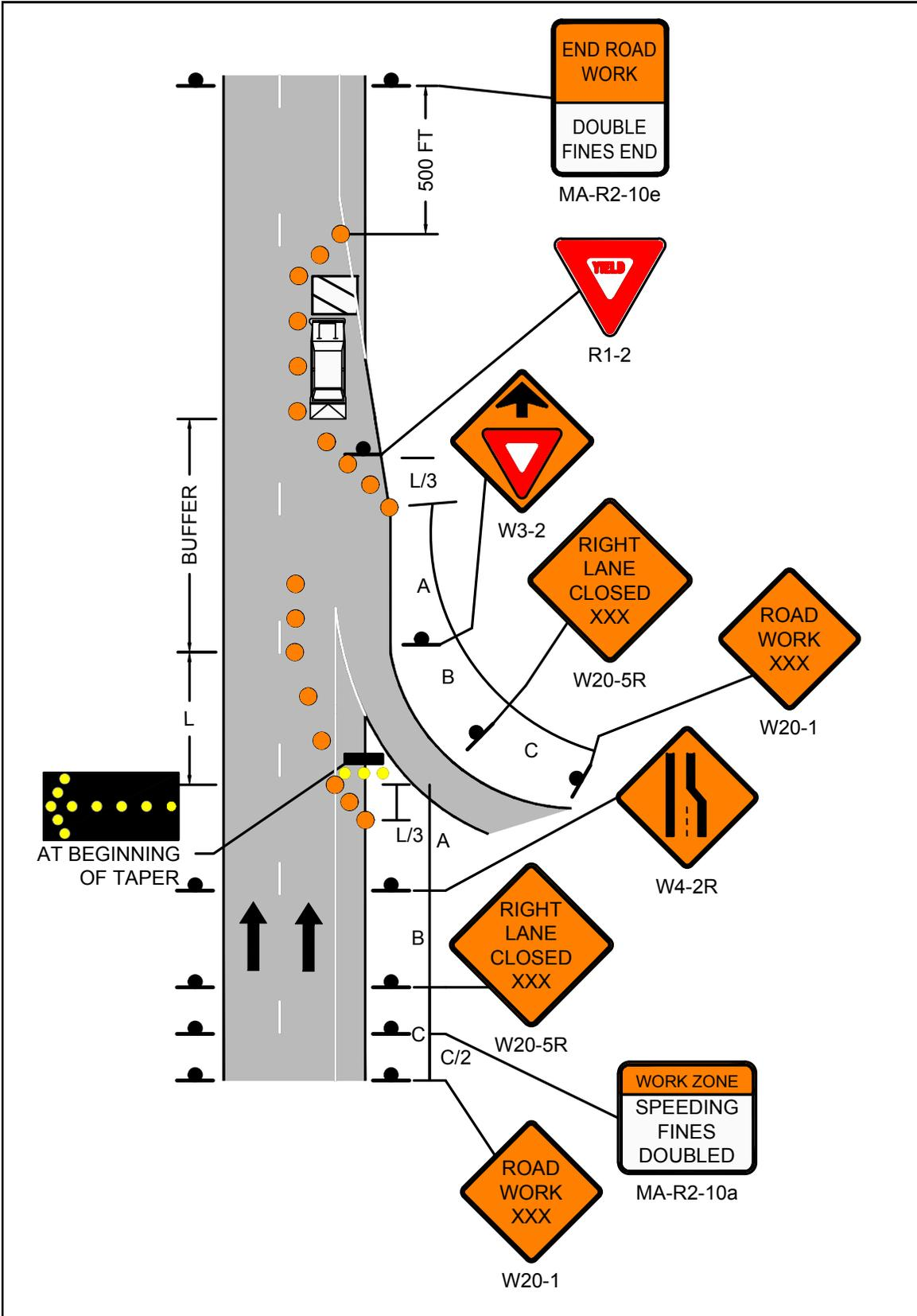

 <p>PAGE 45</p>	<p>Work Zone Safety Standard Details and Drawings</p>	<p>FIGURE 19 STATIONARY OPERATIONS MULTILANE DIVIDED ROADWAY ROADWORK BEYOND ON RAMP</p>
--	---	--

 MASSACHUSETTS DEPARTMENT OF TRANSPORTATION Highway Division PAGE 46	Work Zone Safety Standard Details and Drawings	STATIONARY OPERATIONS MULTILANE DIVIDED ROADWAY ROADWORK BEYOND OFF RAMP
--	--	--

POSTED SPEED LIMIT (MPH)	CHANNELIZATION DEVICES (DRUMS OR CONES)					
	SHOULDER TAPER LENGTH (L/3) (FT)	TRAVEL LANE CLOSURE LENGTH (L) (FT)	TRAVEL LANE SHIFT LENGTH (L/2) (FT)	BUFFER ZONE LENGTH (FT)	DEVICE SPACING (FT)	MIN # OF DEVICES*
25-40	110	320	160	305	20	70
45-55	220	660	330	495	40	55
60-65	260	780	390	645	40	65

* NUMBER OF DEVICES BASED ON 400 FT WORK ZONE.

POSTED SPEED LIMIT (MPH)	SPACING FOR ADVANCE WARNING SIGNS (FT) (A,B,C)
25-40	500 / 500 / 500
45-55	500 / 1000 / 1000
60-65	1000 / 1600 / 2600

NOTES

1. MA-R2-10a LOCATED AT C/2.

LEGEND

-  WORK ZONE
-  CHANNELIZATION DEVICE
-  FLASHING ARROW BOARD
-  PORTABLE CHANGEABLE MESSAGE SIGN
-  TRUCK MOUNTED ATTENUATOR
-  RADAR SPEED FEEDBACK BOARD
-  POLICE DETAIL OR UNIFORMED FLAGGER
-  TEMPORARY PORTABLE RUMBLE STRIP
-  TYPE III BARRICADE

NOT TO SCALE

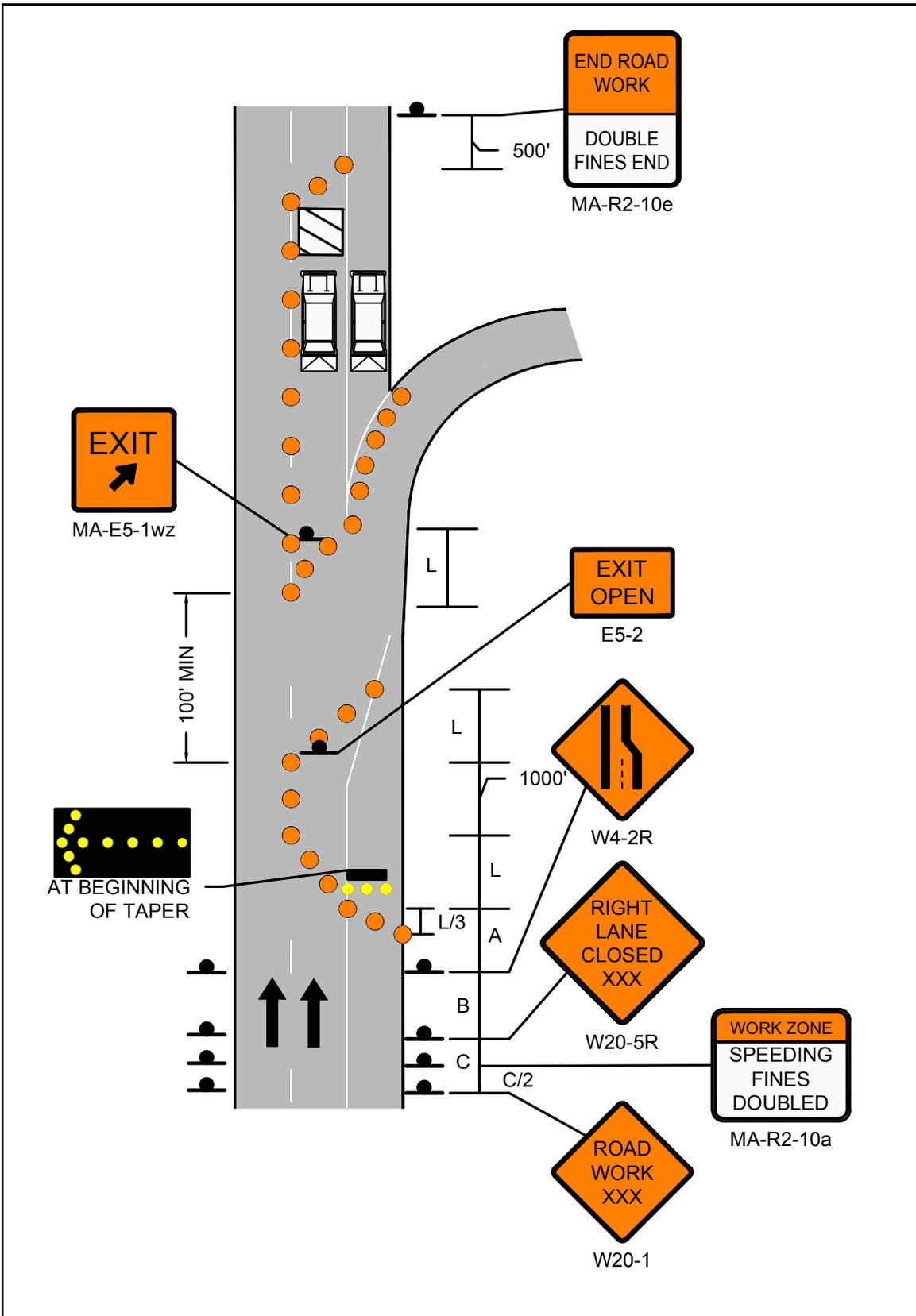

 <p>PAGE 47</p>	<p>Work Zone Safety Standard Details and Drawings</p>	<p>FIGURE 20 STATIONARY OPERATIONS MULTILANE DIVIDED ROADWAY ROADWORK BEYOND OFF RAMP</p>
--	---	---



PAGE 48

Work Zone Safety
Standard Details
and Drawings

MULTILANE DIVIDED ROADWAY
TYPICAL RAMP CLOSURE

POSTED SPEED LIMIT (MPH)	SPACING FOR ADVANCE WARNING SIGNS (FT) (A,B,C)	CHANNELIZATION DEVICES (DRUMS OR CONES)			
		SHOULDER TAPER LENGTH (L/3) (FT)	BUFFER ZONE LENGTH (FT)	DEVICE SPACING (FT)	MIN # OF DEVICES
25-40	500 / 500 / 500	110	305	20	45
45-55	500 / 1000 / 1000	220	495	40	30
60-65	1000 / 1600 / 2600	260	645	40	35

NOTES

1. MA-R2-10a LOCATED AT C/2.
2. * NOT REQUIRED IF RIGHT LANE IS CLOSED IN ADVANCE OF EXIT.
3. ** OPTIONAL AT ENGINEER'S DISCRETION.

LEGEND

-  WORK ZONE
-  CHANNELIZATION DEVICE
-  FLASHING ARROW BOARD
-  PORTABLE CHANGEABLE MESSAGE SIGN
-  TRUCK MOUNTED ATTENUATOR
-  RADAR SPEED FEEDBACK BOARD
-  POLICE DETAIL OR UNIFORMED FLAGGER
-  TEMPORARY PORTABLE RUMBLE STRIP
-  TYPE III BARRICADE

NOT TO SCALE

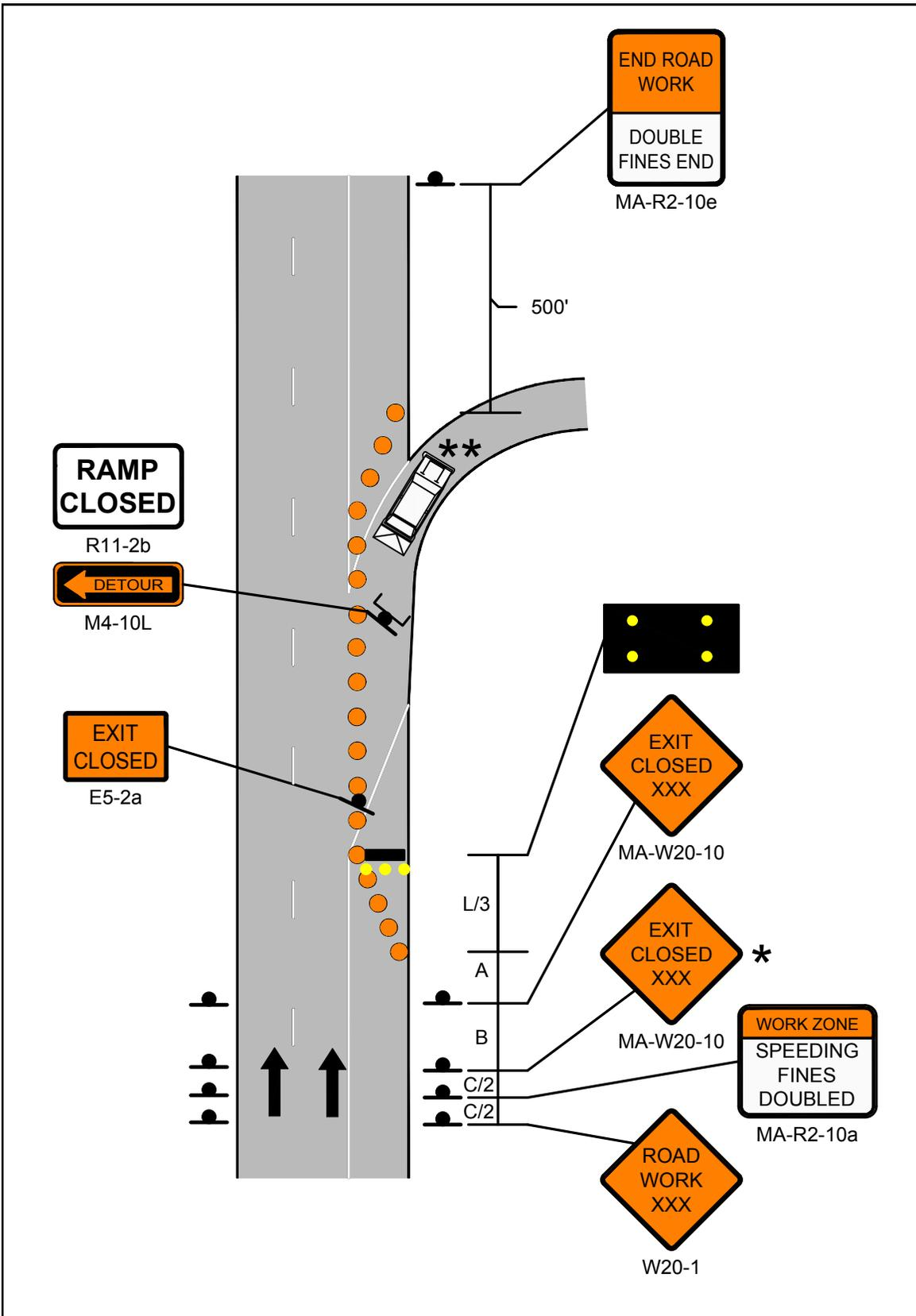



PAGE 50

Work Zone Safety
Standard Details
and Drawings

MULTILANE DIVIDED ROADWAY
TYPICAL CLOVERLEAF RAMP CLOSURE

POSTED SPEED LIMIT (MPH)	SPACING FOR ADVANCE WARNING SIGNS (FT) (A,B,C)	CHANNELIZATION DEVICES (DRUMS OR CONES)			
		SHOULDER TAPER LENGTH (L/3) (FT)	BUFFER ZONE LENGTH (FT)	DEVICE SPACING (FT)	MIN # OF DEVICES
25-40	500 / 500 / 500	110	305	20	45
45-55	500 / 1000 / 1000	220	495	40	30
60-65	1000 / 1600 / 2600	260	645	40	35

NOTES

1. MA-R2-10a LOCATED AT C/2.
2. * NOT REQUIRED IF RIGHT LANE IS CLOSED IN ADVANCE OF EXIT.
3. ** OPTIONAL AT ENGINEER'S DISCRETION.

LEGEND

-  WORK ZONE
-  CHANNELIZATION DEVICE
-  FLASHING ARROW BOARD
-  PORTABLE CHANGEABLE MESSAGE SIGN
-  TRUCK MOUNTED ATTENUATOR
-  RADAR SPEED FEEDBACK BOARD
-  POLICE DETAIL OR UNIFORMED FLAGGER
-  TEMPORARY PORTABLE RUMBLE STRIP
-  TYPE III BARRICADE

NOT TO SCALE

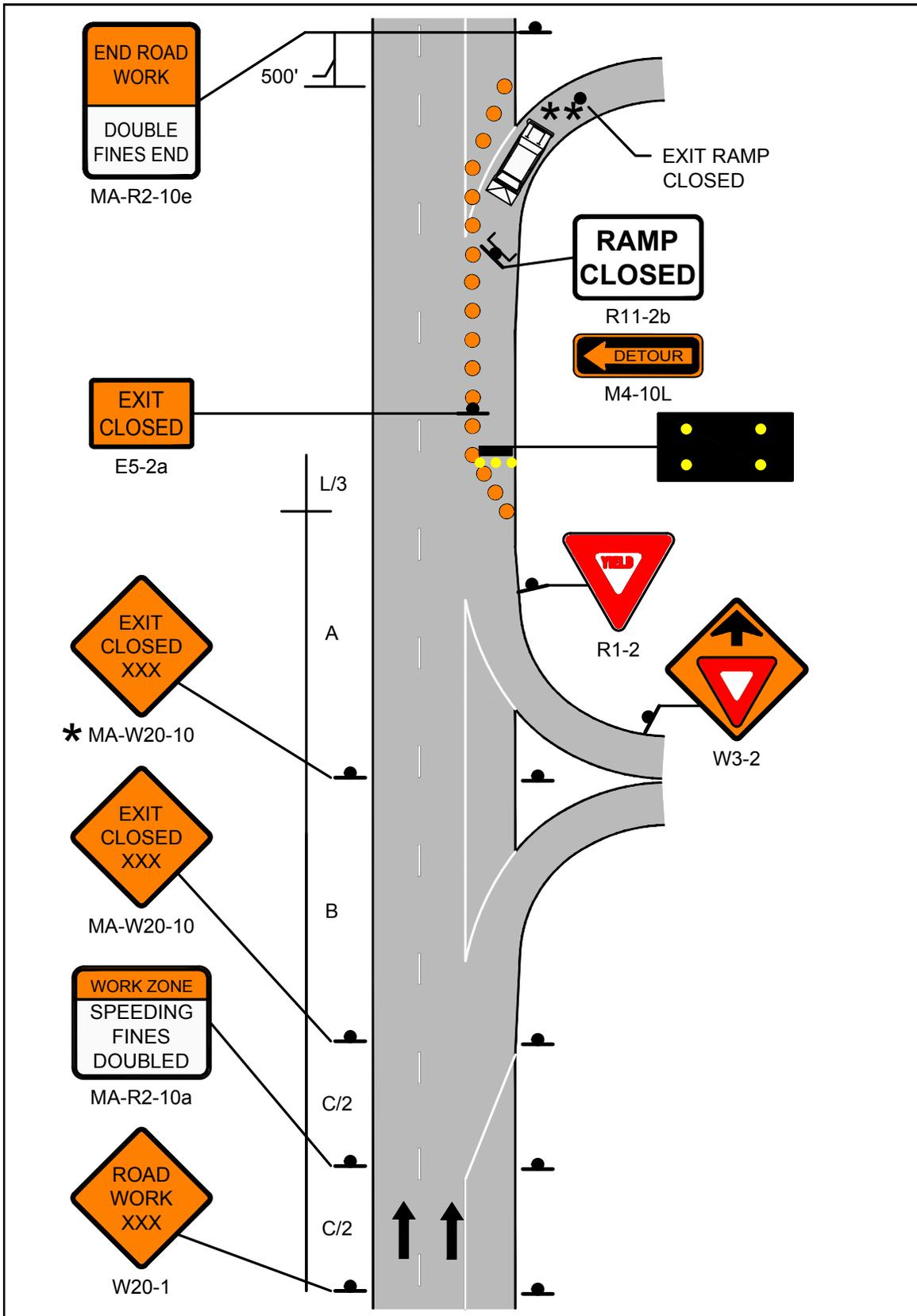

 <p>PAGE 51</p>	<p>Work Zone Safety Standard Details and Drawings</p>	<p>FIGURE 22 MULTILANE DIVIDED ROADWAY TYPICAL CLOVERLEAF RAMP CLOSURE</p>
--	---	--

 <p>PAGE 52</p>	<p>Work Zone Safety Standard Details and Drawings</p>	<p>MULTILANE DIVIDED ROADWAY TYPICAL RAMP CLOSURE ADVANCE SIGNING</p>
--	---	---

NOTES

1. IF THE CLOSED RAMP IS LOCATED DOWNSTREAM FROM THE PROPOSED DETOUR ROUTE/RAMP, A PCMS SHALL BE POSITIONED AT A SUFFICIENT DISTANCE IN ADVANCE OF THE DETOUR ROUTE/RAMP AND SHOULD STATE WHICH RAMP IS CLOSED AND WHICH SHALL BE USED FOR THE DETOUR.
2. IF THE CLOSED RAMP IS LOCATED UPSTREAM FROM THE PROPOSED DETOUR ROUTE/RAMP, A PCMS SHALL BE POSITIONED PRIOR TO THE CLOSED RAMP AND SHOULD STATE WHICH RAMP IS CLOSED AND WHICH SHALL BE USED FOR THE DETOUR.
3. A SUFFICIENT NUMBER OF DETOUR SIGNS (M4-9 SERIES) SHOULD BE DEPLOYED TO PROPERLY DIRECT DETOURED TRAFFIC. SIGN SPACING SHALL BE AT THE DIRECTION OF THE ENGINEER.

LEGEND

-  WORK ZONE
-  CHANNELIZATION DEVICE
-  FLASHING ARROW BOARD
-  PORTABLE CHANGEABLE MESSAGE SIGN
-  TRUCK MOUNTED ATTENUATOR
-  RADAR SPEED FEEDBACK BOARD
-  POLICE DETAIL OR UNIFORMED FLAGGER
-  TEMPORARY PORTABLE RUMBLE STRIP
-  TYPE III BARRICADE

NOT TO SCALE

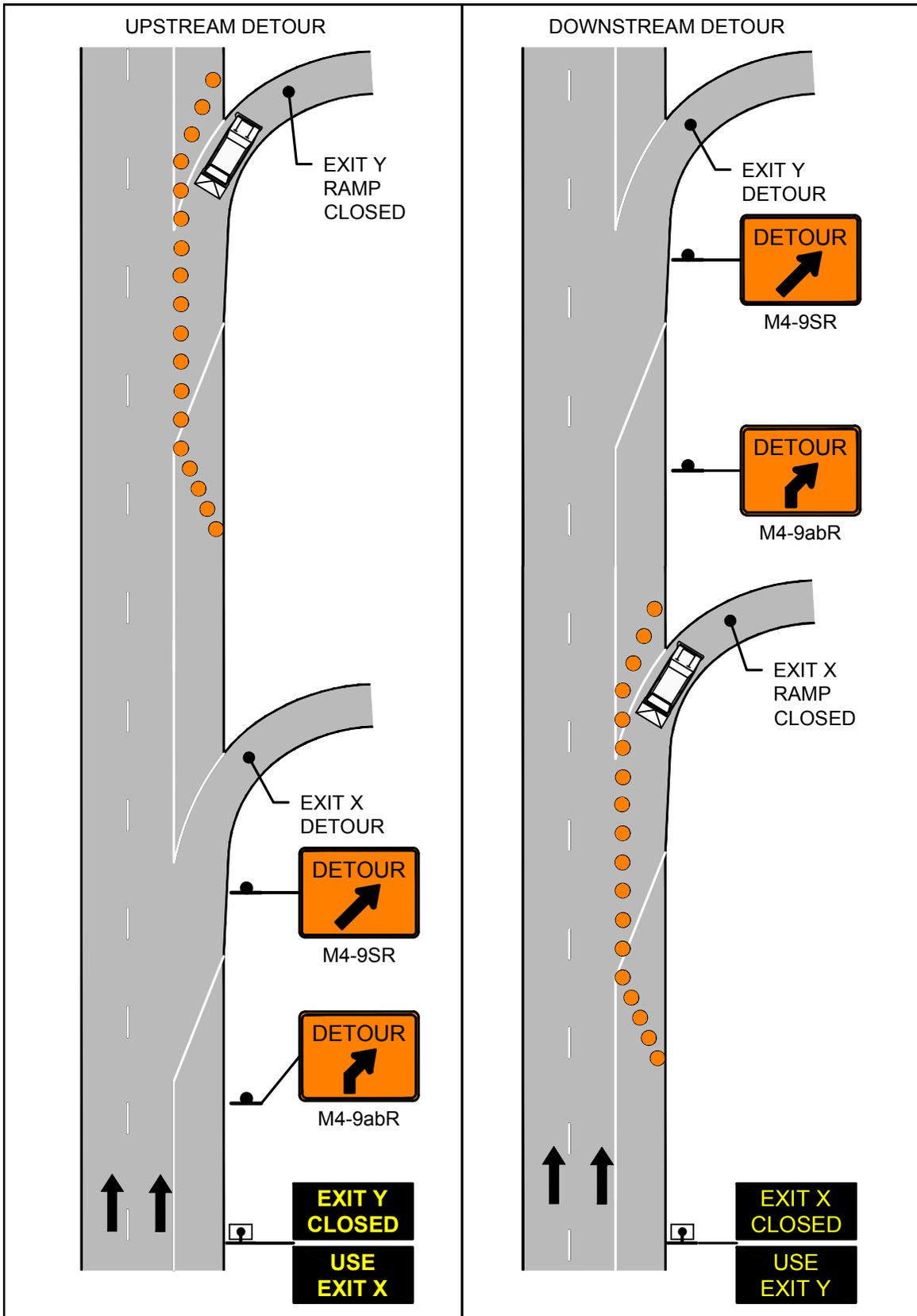

FIGURE 23
MULTILANE DIVIDED ROADWAY
TYPICAL RAMP CLOSURE
ADVANCE SIGNING

 MASSACHUSETTS DEPARTMENT OF TRANSPORTATION HIGHWAY DIVISION PAGE 54	Work Zone Safety Standard Details and Drawings	FIGURE 24-1 MULTILANE DIVIDED ROADWAY PLACEMENT OF TEMPORARY PORTABLE RUMBLE STRIPS SHEET 1 OF 2
--	--	--

POSTED REGULATORY OR WORK ZONE SPEED	SEPARATION BETWEEN RUMBLE STRIPS
Above 55-mph	20-feet
36-mph to 55-mph	15-feet
35-mph and under	10-feet

POSTED SPEED LIMIT (MPH)	SPACING FOR ADVANCE WARNING SIGNS (FT) (A,B,C)	TANGENT LENGTH BETWEEN TAPERS (T) (FT)
25-40	500 / 500 / 500	640
45-55	500 / 1000 / 1000	1320
60-65	1000 / 1600 / 2600	1560

NOTES

1. THE INTENTION OF THESE DETAILS IS ONLY TO DEPICT THE PLACEMENT OF TEMPORARY PORTABLE RUMBLE STRIPS (TPRS) IN RELATIONSHIP TO THE TAPER AND THE BUFFER OF A SINGLE- OR MULTI-LANE CLOSURE. THE DEPICTION OF THE NUMBER AND SPACING OF ALL OTHER TRAFFIC CONTROL DEVICES IS NOT TO SCALE. REFER TO OTHER DETAILS FOR LANE CLOSURES FOR THE PLACEMENT AND NUMBER OF ALL OTHER TRAFFIC CONTROL DEVICES.
2. THESE DETAILS ONLY DEPICT RIGHT LANE CLOSURES. LEFT LANE CLOSURES SHOULD UTILIZE A MIRROR IMAGE OF THESE SETUPS, STARTING WITH CLOSURE OF THE LEFTMOST LANE.
3. ★ THIS TPRS ARRAY IS OPTIONAL AT THE ENGINEER'S DISCRETION. IF USED, IT SHOULD BE PLACED ADJACENT TO THE BUFFER.
4. DETAILS SHOW THE MINIMUM NUMBER OF TPRS REQUIRED. ADDITIONAL MAY BE USED IF CONDITIONS WARRANT.

LEGEND

- CHANNELIZATION DEVICE
- ▣ TRUCK MOUNTED ATTENUATOR
- ≡≡≡ TEMPORARY PORTABLE RUMBLE STRIP

NOT TO SCALE

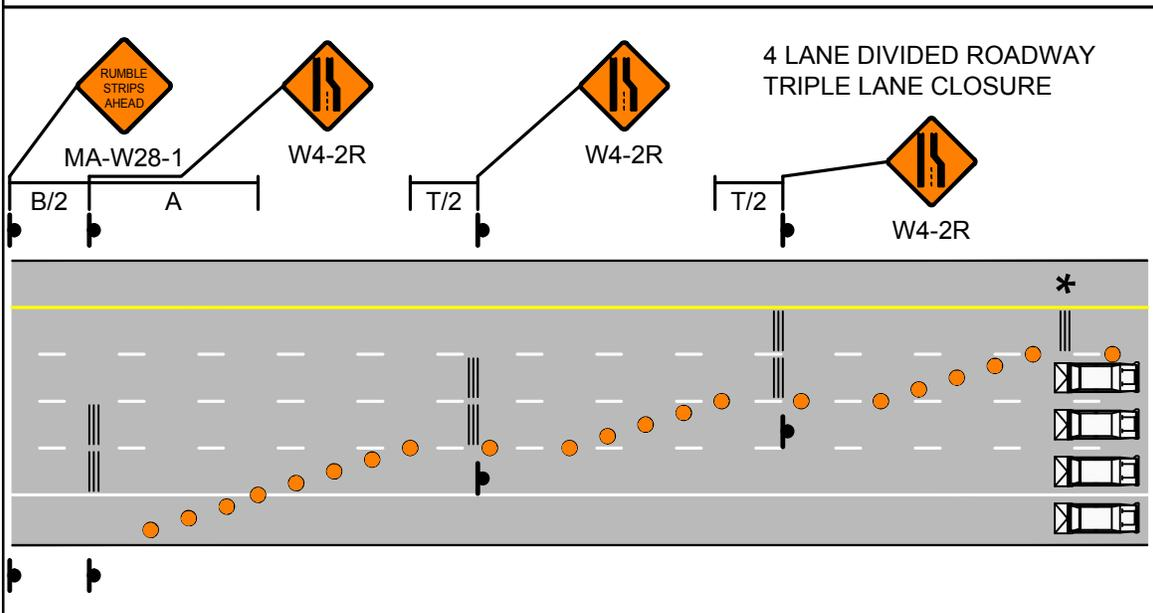

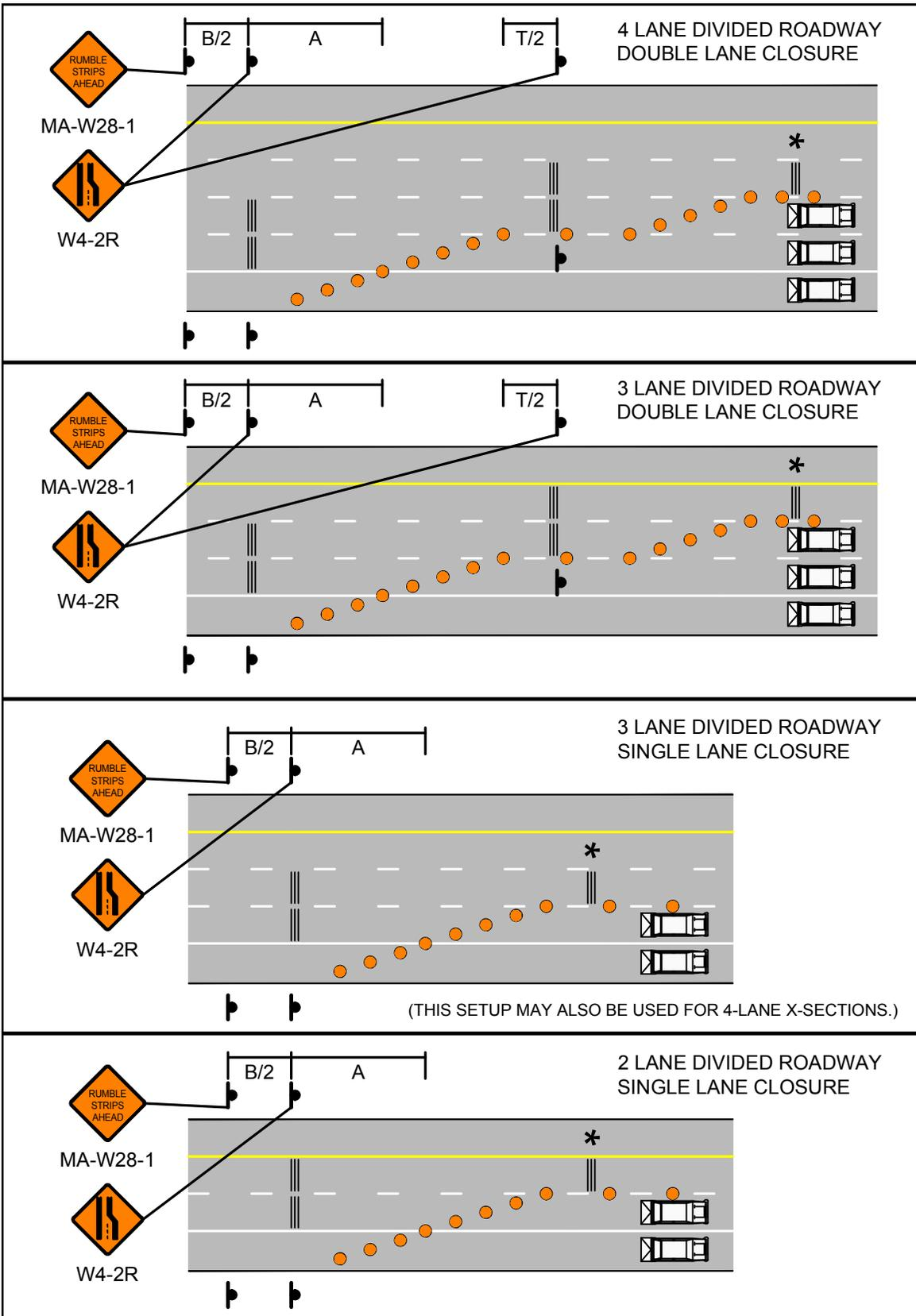

 <p>PAGE 56</p>	<p>Work Zone Safety Standard Details and Drawings</p>	<p>NOTES FOR MOBILE OPERATIONS</p>
--	---	------------------------------------

Notes for Mobile Operations

- Unless otherwise stated, these notes shall apply to all Mobile Operation setups.
 - Additional, setup-specific notes may be found on individual sheets.
1. The Supervisor shall travel the designated roadway prior to scheduling the work to ensure that sufficient and appropriate traffic control devices will be available. Special consideration shall be exercised to ensure that appropriate traffic controls be placed in areas that will have limited visibility of the work areas or any associated traffic queues.
 2. Vehicles used for these operations shall be made highly visible with appropriate equipment such as flashing lights, rotating beacons, flags, signs, flashing arrow boards, and/or portable changeable message signs. Any signs mounted to these vehicles shall not obscure the visibility of other devices.
 3. All vehicles shown may not be required based upon roadway conditions. However, when needed and practical, additional shadow vehicles and equipment to warn and protect motorists and workers should be used. Based upon roadway conditions, the addition of a police detail with cruiser may be used for additional protection or warning for the traveling public.
 4. The distance between the work and shadow vehicle(s) may vary according to the terrain and other factors. Shadow vehicles are used to warn traffic of the operations ahead. Whenever adequate sight distance exists, the shadow vehicle(s) should maintain the minimum appropriate distance and maintain the same speed to prevent non-work related vehicles from entering the work convoy. If this formation cannot be maintained then additional traffic control devices should be deployed in advance of any vertical or horizontal curves that may restrict the sight distance of an oncoming vehicle to either the work vehicle or associated traffic queue.
 5. All shadow vehicles shall be equipped with a truck or trailer mounted attenuator (TMA) and a flashing arrow board.
 6. Signs should be covered or turned from view when work is not in progress.
 7. Portable changeable message signs may be used in lieu of MA-W21-9 signs and any signs mounted directly to a shadow vehicle.

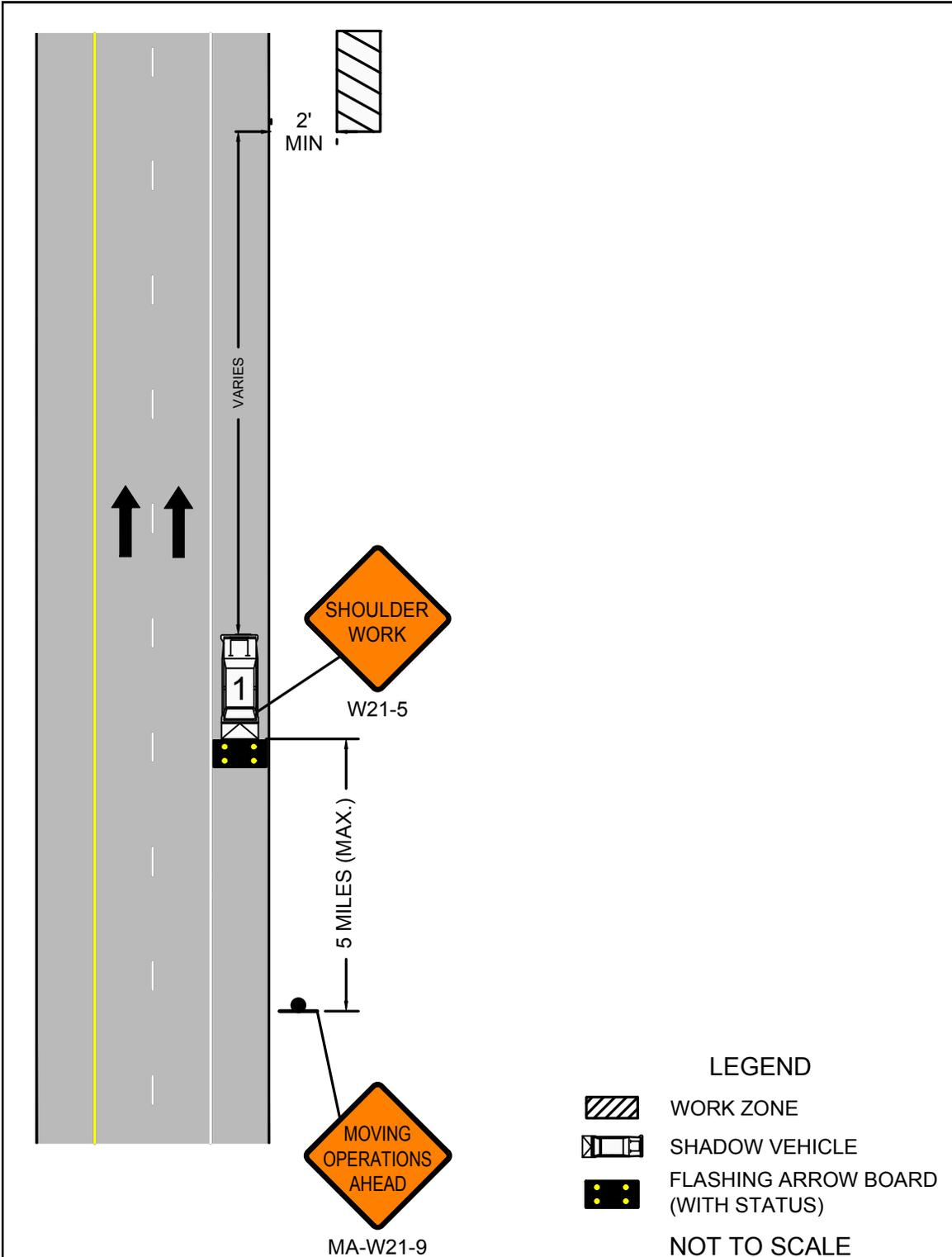

NOTES

1. IF THE WORK AREA IS SUFFICIENTLY AWAY FROM THE EDGE OF ROADWAY (20' MINIMUM) THEN SIGNS AND VEHICLES MAY NOT BE REQUIRED.

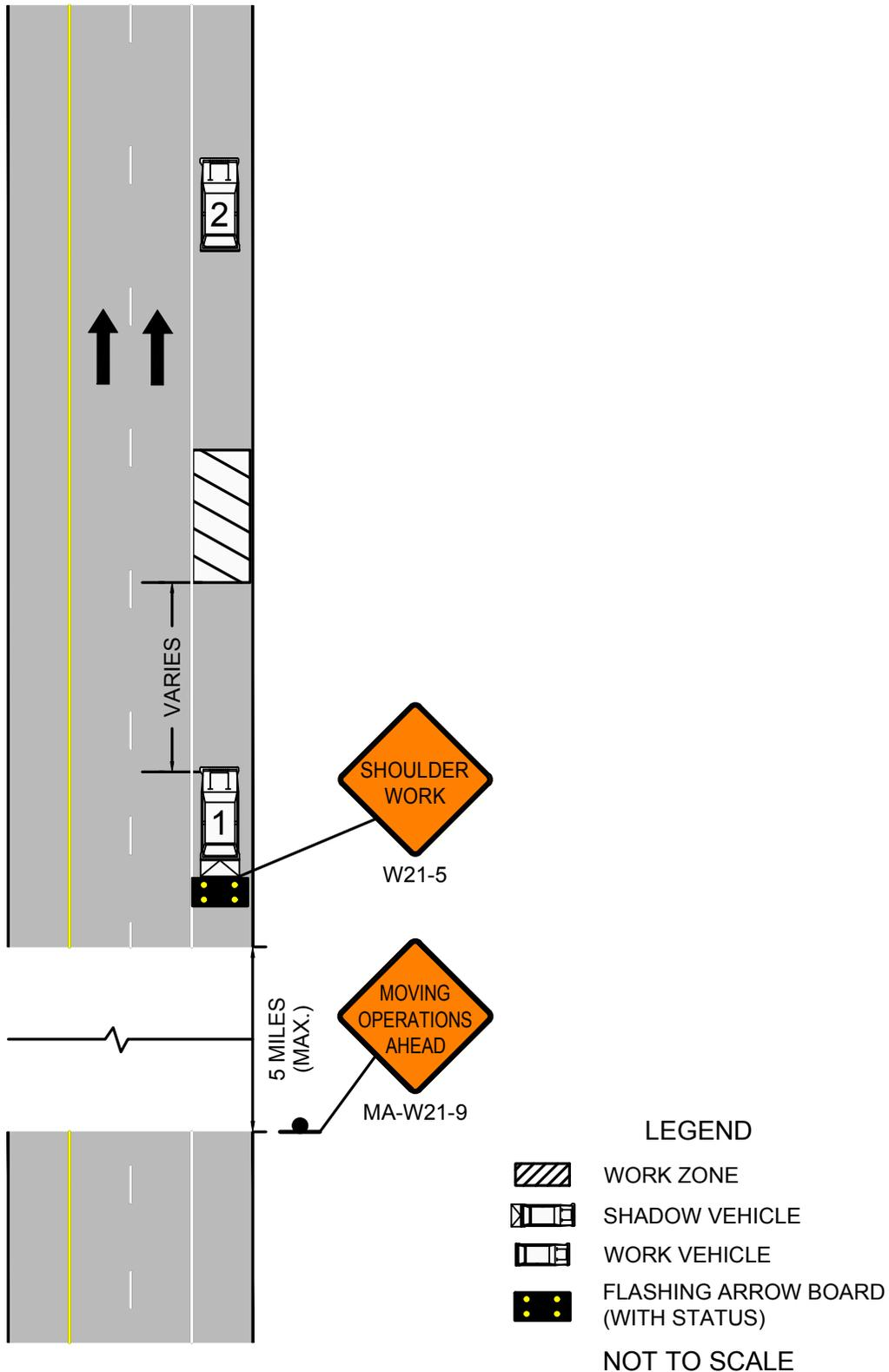

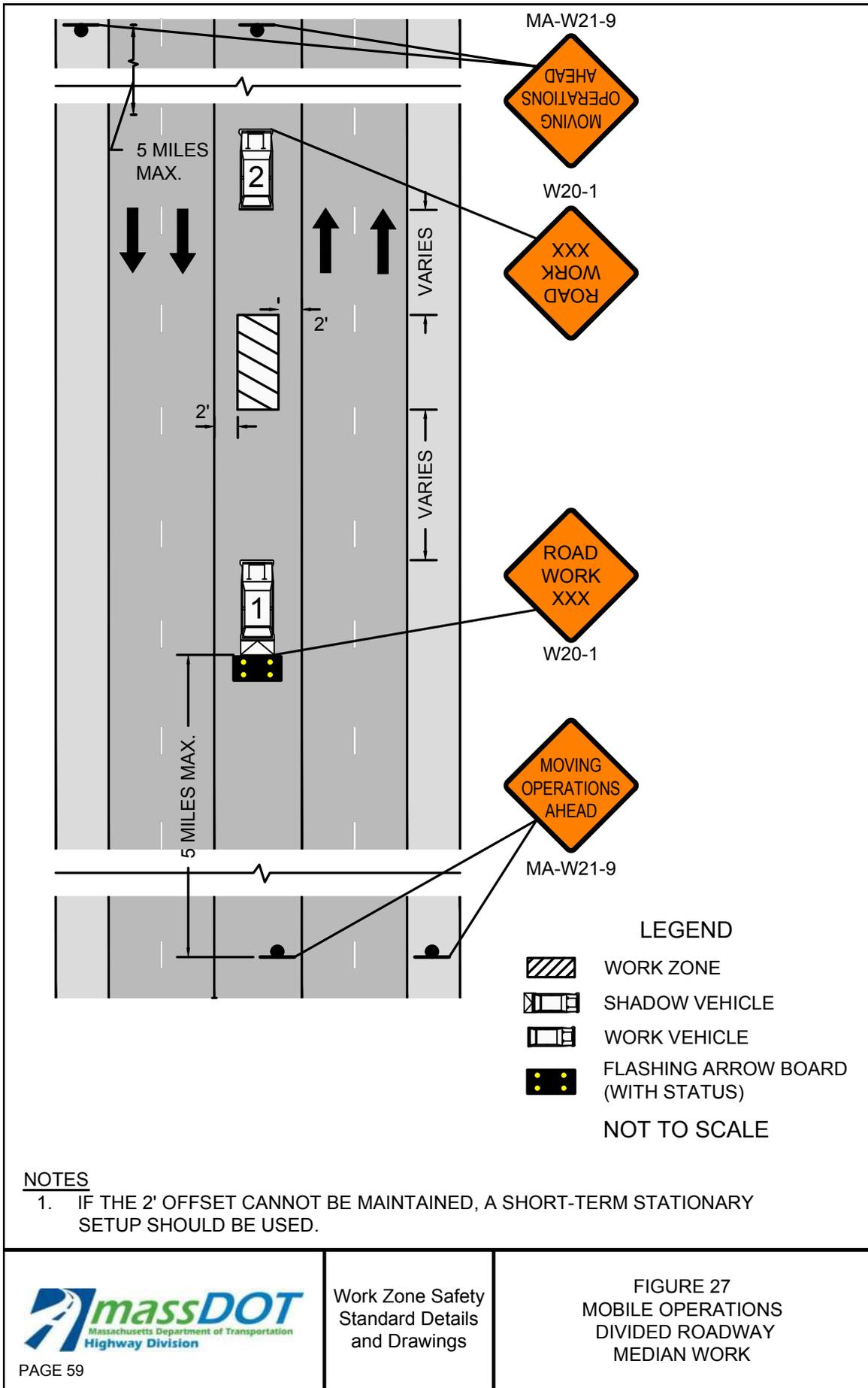
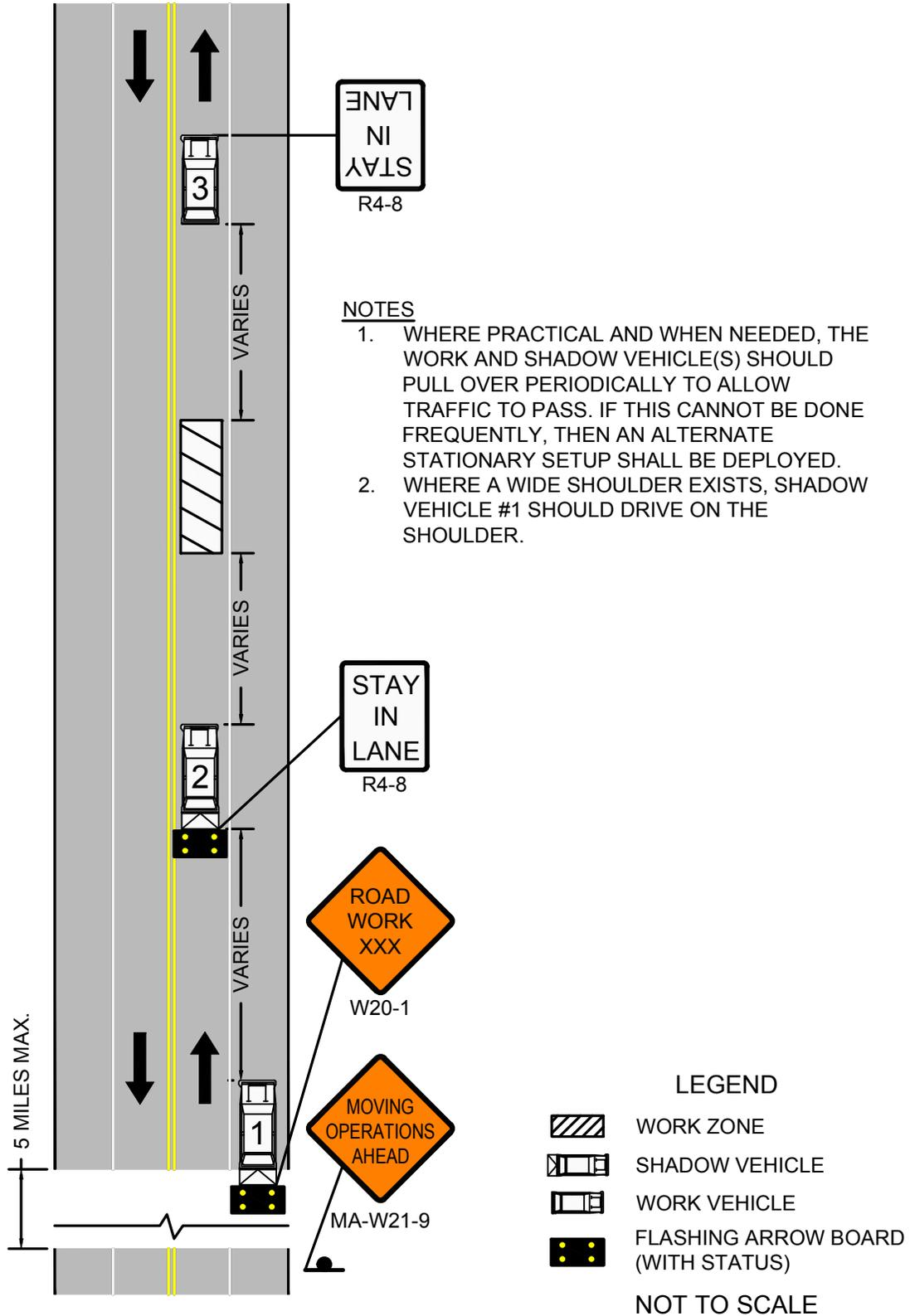



FIGURE 28
MOBILE OPERATIONS
UNDIVIDED TWO LANE ROADWAY
HALF OF ROADWAY CLOSED



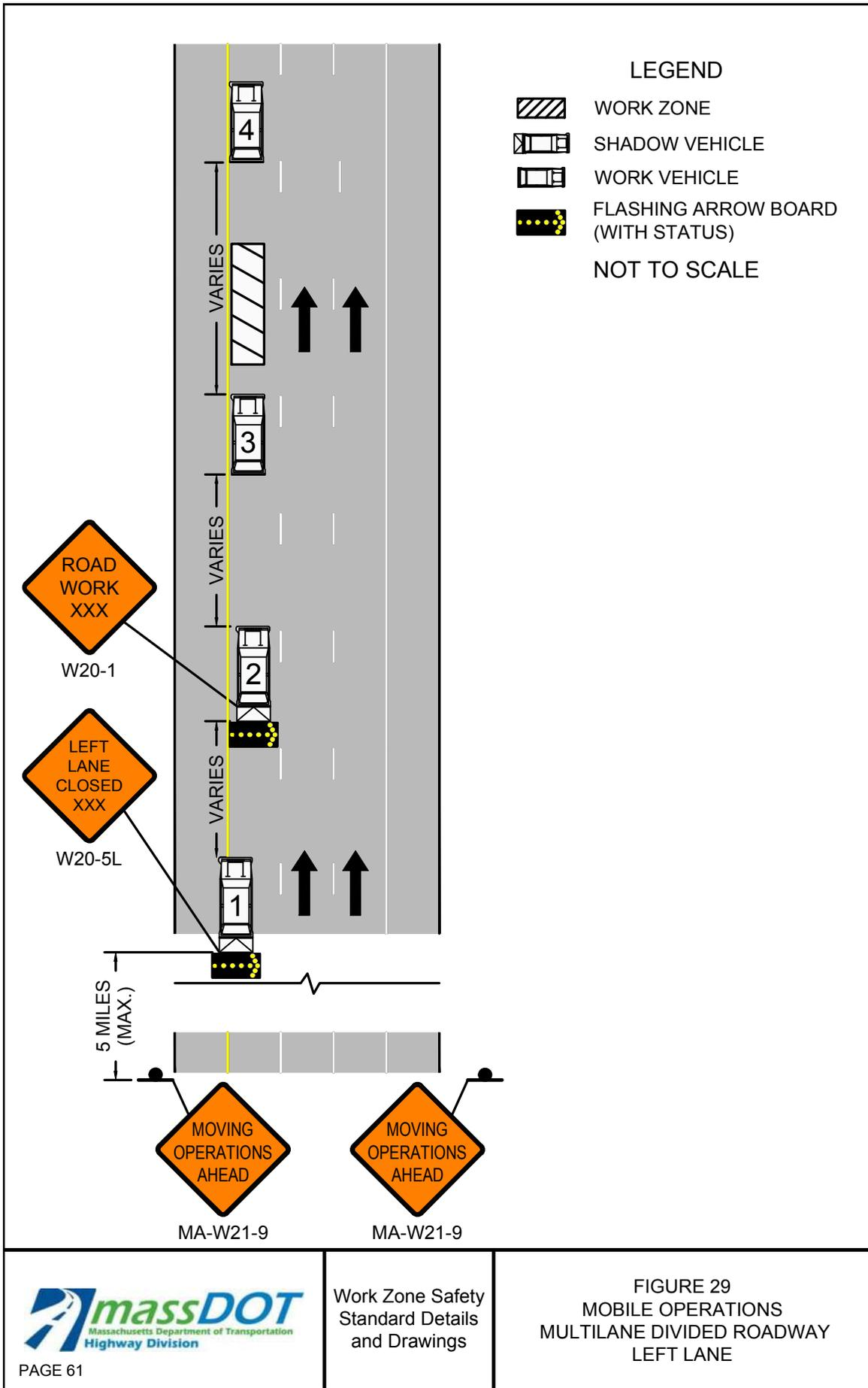
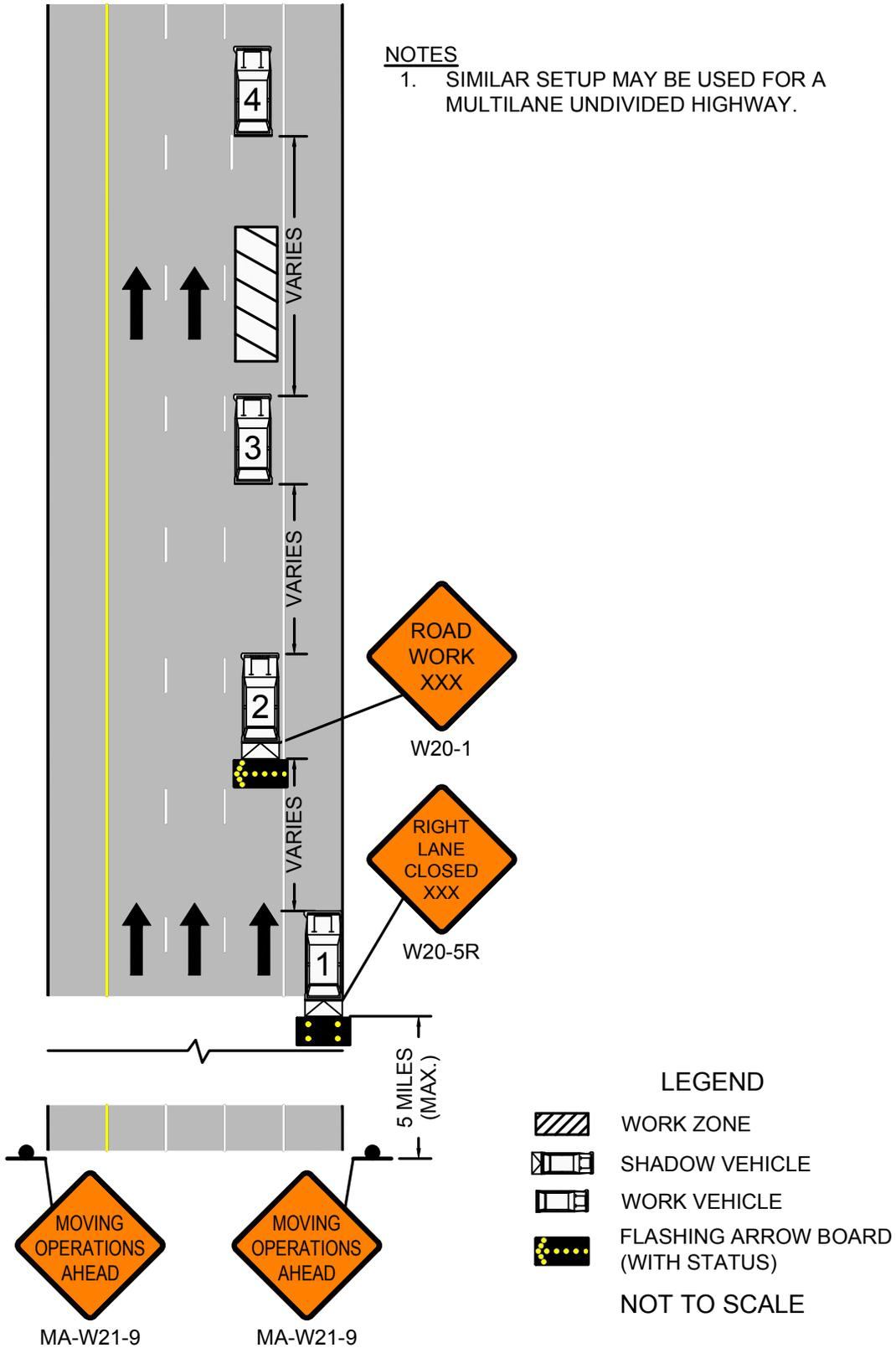
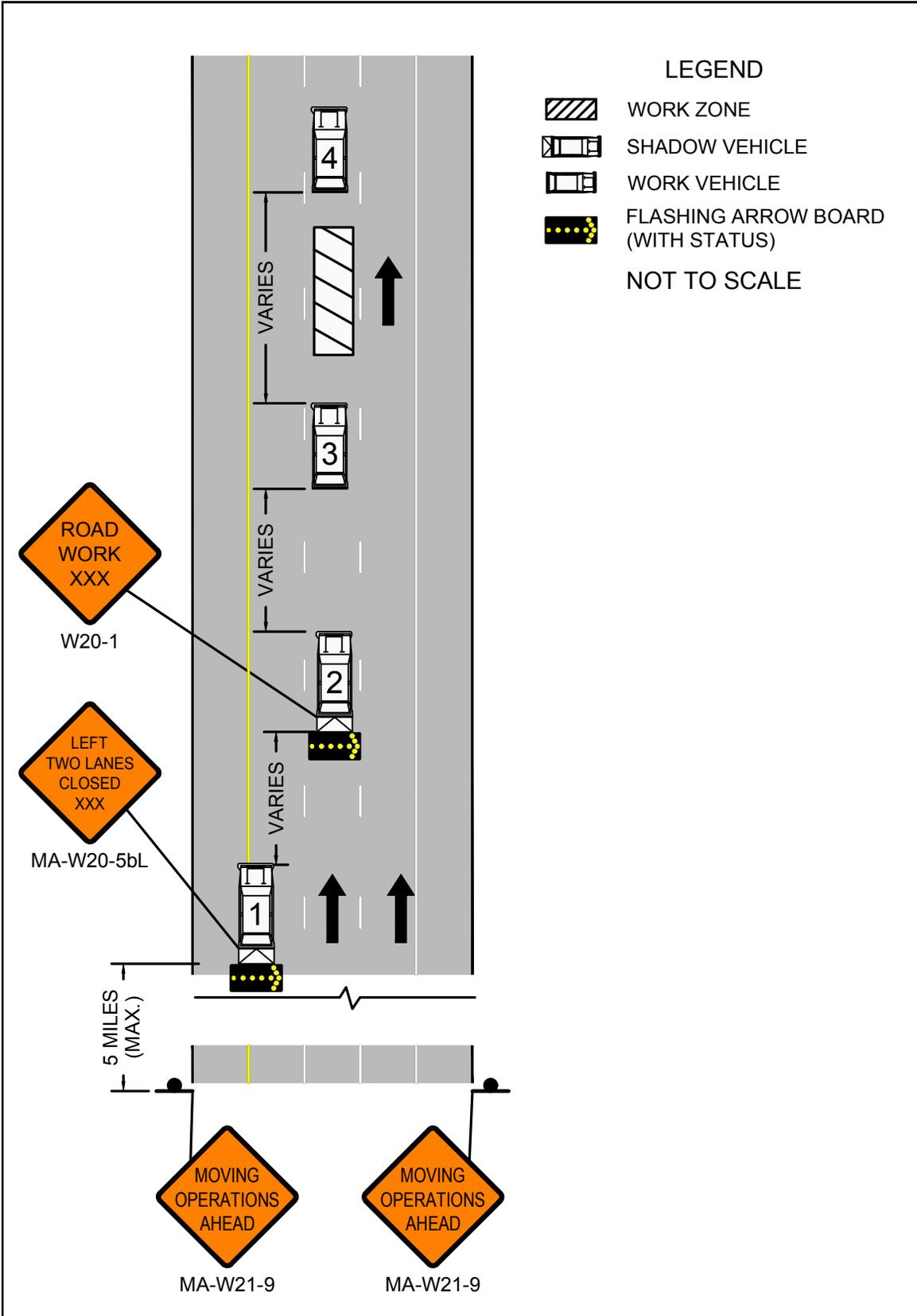
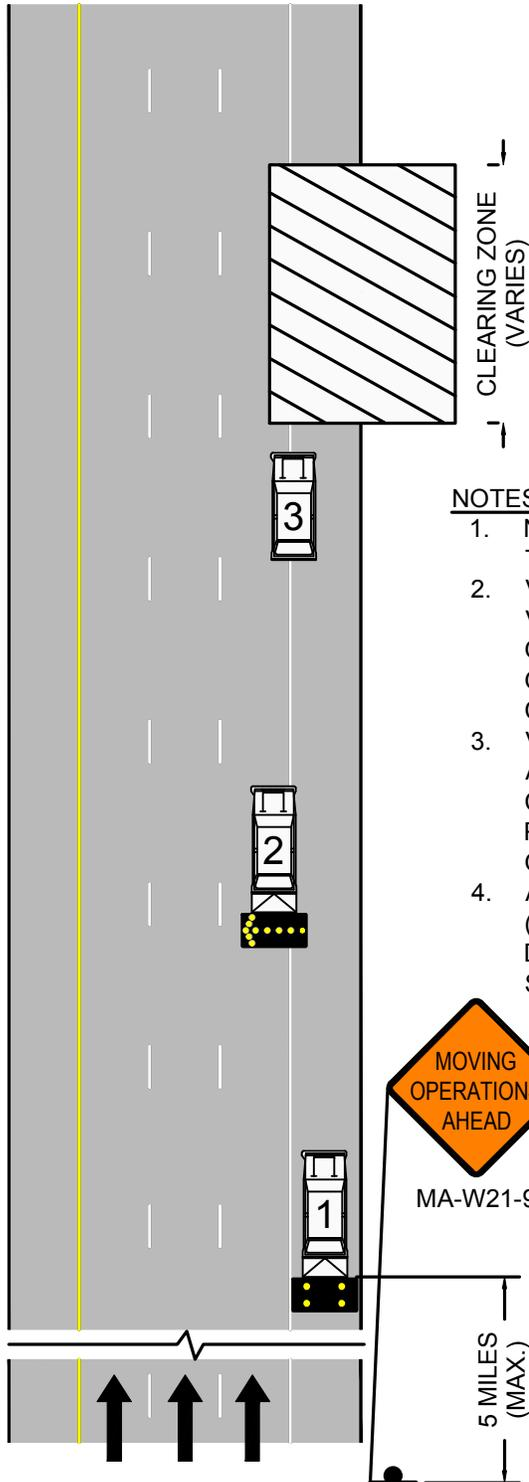



FIGURE 30
MOBILE OPERATIONS
MULTILANE DIVIDED ROADWAY
RIGHT LANE







NOTES

1. NO OTHER NOTES ARE APPLICABLE TO THIS DETAIL.
2. VEHICLE #3 IS A SNOW/DEBRIS REMOVAL VEHICLE AND SHALL ALWAYS BE AWARE OF THE SURROUNDINGS. MORE THAN ONE VEHICLE MAY BE USED IN THE CLEARING ZONE.
3. VEHICLE #1 SHOULD BE EQUIPPED WITH A PCMS, A TMA, AND STAY IN VISUAL CONTACT WITH VEHICLE #3 WHILE PROVIDING AMPLE WARNING TO ONCOMING TRAFFIC.
4. A POLICE DETAIL WITH BLUE LIGHTS (OPTIONAL) SHALL REMAIN DOWNSTREAM OF VEHICLE #1 IN THE SHOULDER.

LEGEND

-  WORK ZONE
-  SHADOW VEHICLE
-  WORK VEHICLE
-  FLASHING ARROW BOARD (WITH STATUS)

NOT TO SCALE

Notes for Traffic Emergency or Incident Operations

- The goal is to increase awareness of during traffic emergencies or incidents.
- These signs are to be used to differentiate from the traditional construction work zone and an emergency or incident.
- Upon arrival MassDOT First Responders shall assess the magnitude of the scene to determine if the incident is likely to last an hour or more in duration which would trigger the requirement to use these signs.
- Place the “Emergency Ahead” sign on the same side of the road as the incident, if possible, for up to an hour. Emergency response signs should be put up for all incidents and emergencies as soon as possible.
- Place the emergency sign 500 to 1000 feet before the first channelization devices.
- As an incident evolves this sign would be used as a secondary sign with all other emergency controls put in place.
- Only use “MERGE” signs where applicable (Not on 2 lane roads).
- Use MERGE signs on Multi-lane Roads to move traffic away from the incident and keep them in a safe lane.
- Place the MERGE sign about 500 feet before the closure.
- If additional signs are available, they should be placed accordingly as a sign informing people coming in the other direction or on the opposite side of the roadway.
- Use 12 emergency cones spaced 40 to 80 feet apart to form a taper and protect the scene.
- Sequential flashing lights/flares may be used in lieu of or to supplement cones.
- During a major incident that will last for a long duration, the EMERGENCY AHEAD sign should be moved back before an intersecting road or ramp to alert travelers and give them an option of using an alternate route. (Be sure all other devices are in place before moving this sign).

Standard Emergency Signs (36"x36" or 48"x48")



MA-W20-9

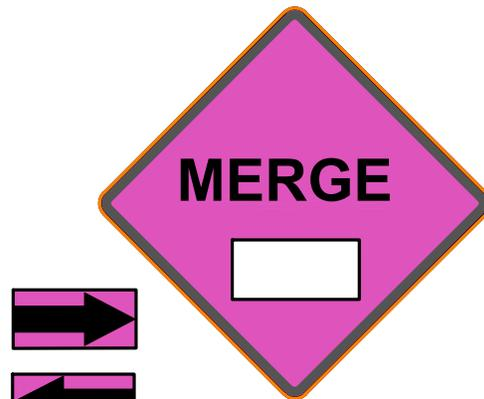

MA-W4-2aR/L

 <p>PAGE 65</p>	<p>Work Zone Safety Standard Details and Drawings</p>	<p>NOTES FOR TRAFFIC EMERGENCY/ INCIDENT OPERATIONS</p>
--	---	---

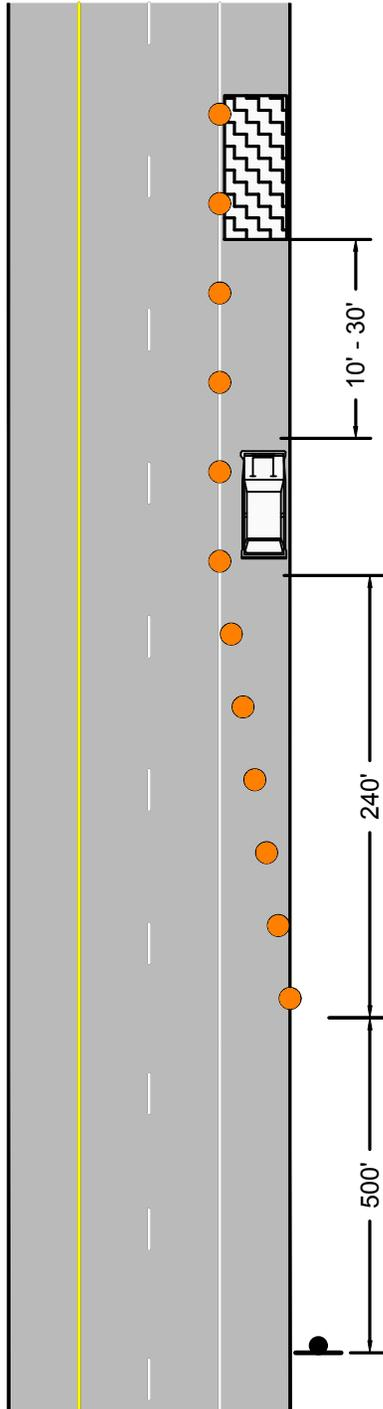

FIGURE 33
EMERGENCY RESPONSE
ANY ROADWAY
SHOULDER ENCROACHMENT

LEGEND

-  EMERGENCY AREA
-  CHANNELIZATION DEVICE
-  EMERGENCY RESPONSE VEHICLE

NOT TO SCALE



ORDER OF RESPONSE ACTIVITIES

1. ACTIVATE HAZARD WARNING LIGHTS AND FLASHERS. PULL VEHICLE OVER TO THE RIGHT EDGE OF TRAVEL LANE BEFORE STOPPING.
2. IF EMERGENCY INVOLVES AN INJURY, SKIP TO STEP 4 THEN RETURN TO STEP 3.
3. ERECT SIGNS AND PLACE TRAFFIC CONES. USE 40' SPACING BETWEEN CONES.
4. TEND TO EMERGENCY/INCIDENT.

NOTES

1. ON HILLY TERRAIN, SHARP CURVES, IN HEAVY TRAFFIC, OR WITH HIGH SPEEDS, CONE SPACING MAY BE DOUBLED TO 80'.
2. REQUEST ADDITIONAL ASSISTANCE AND/OR TRAFFIC CONTROL DEVICES, IF NEEDED.



MA-W20-9

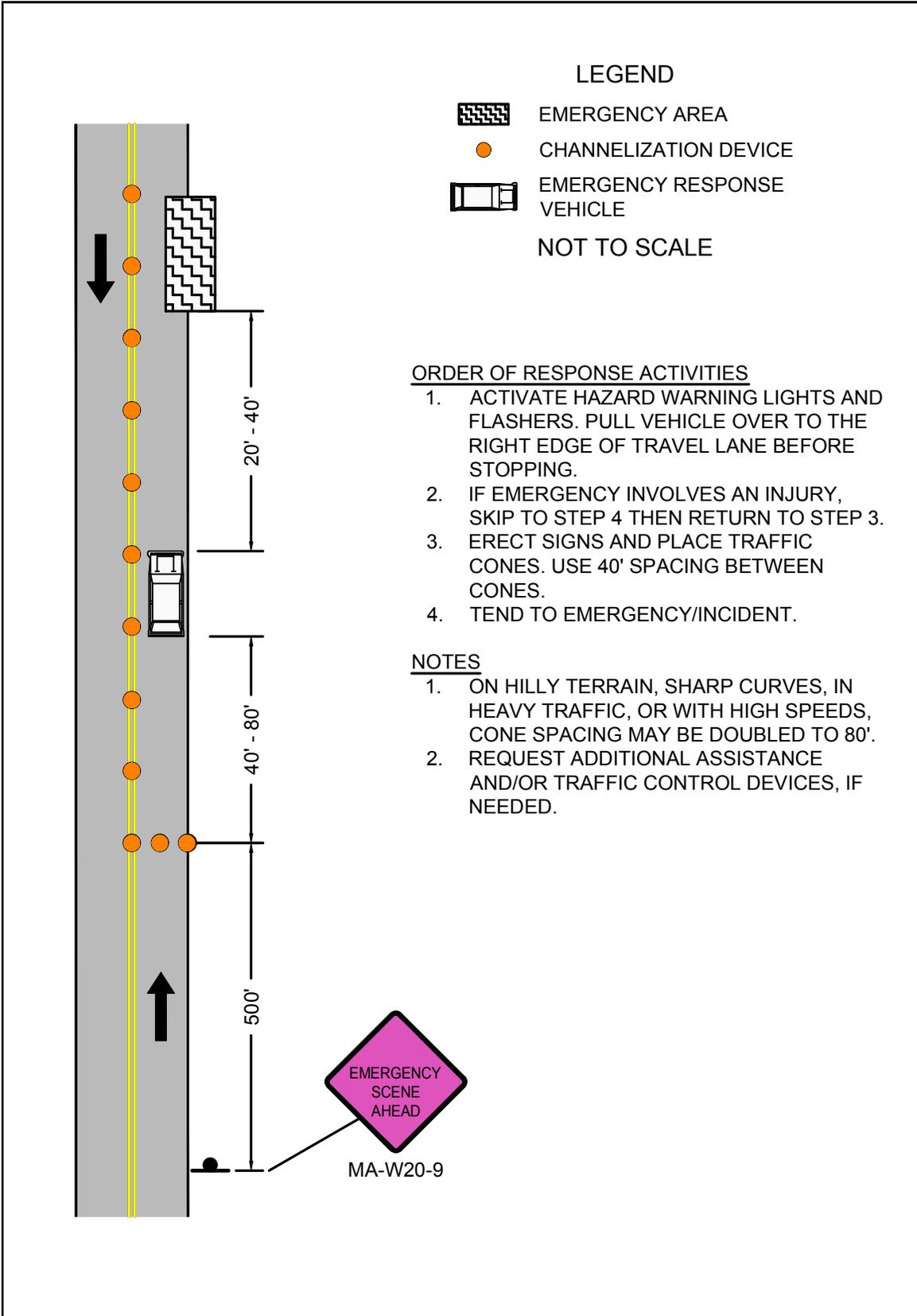

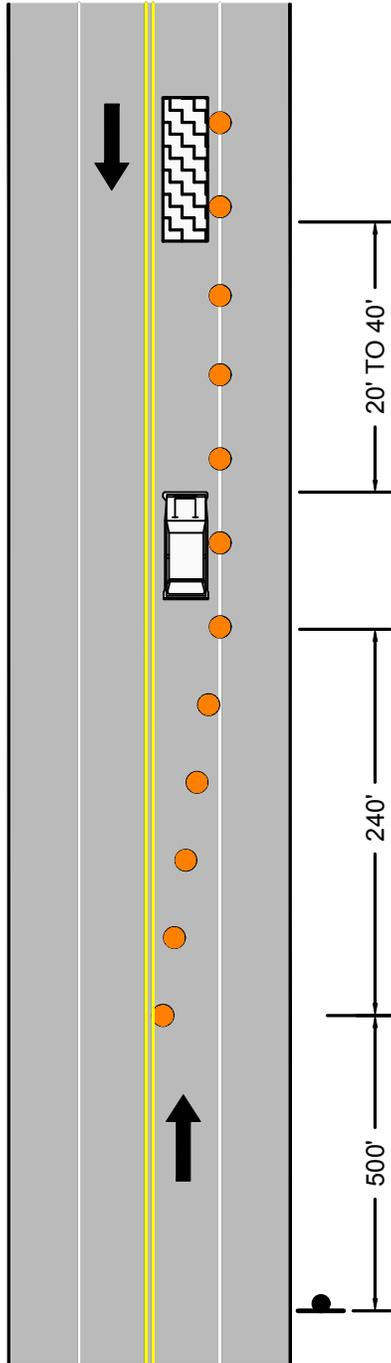

FIGURE 35
EMERGENCY RESPONSE
TWO LANE ROADWAY
TRAVERSABLE SHOULDER
SINGLE LANE ENCROACHMENT

LEGEND

-  EMERGENCY AREA
-  CHANNELIZATION DEVICE
-  EMERGENCY RESPONSE VEHICLE

NOT TO SCALE



ORDER OF RESPONSE ACTIVITIES

1. ACTIVATE HAZARD WARNING LIGHTS AND FLASHERS. PULL VEHICLE OVER TO THE LEFT EDGE OF TRAVEL LANE BEFORE STOPPING.
2. IF EMERGENCY INVOLVES AN INJURY, SKIP TO STEP 4 THEN RETURN TO STEP 3.
3. ERECT SIGNS AND PLACE TRAFFIC CONES. USE 40' SPACING BETWEEN CONES.
4. TEND TO EMERGENCY/INCIDENT.

NOTES

1. ON HILLY TERRAIN, SHARP CURVES, IN HEAVY TRAFFIC, OR WITH HIGH SPEEDS, CONE SPACING MAY BE DOUBLED TO 80'.
2. REQUEST ADDITIONAL ASSISTANCE AND/OR TRAFFIC CONTROL DEVICES, IF NEEDED.



MA-W20-9

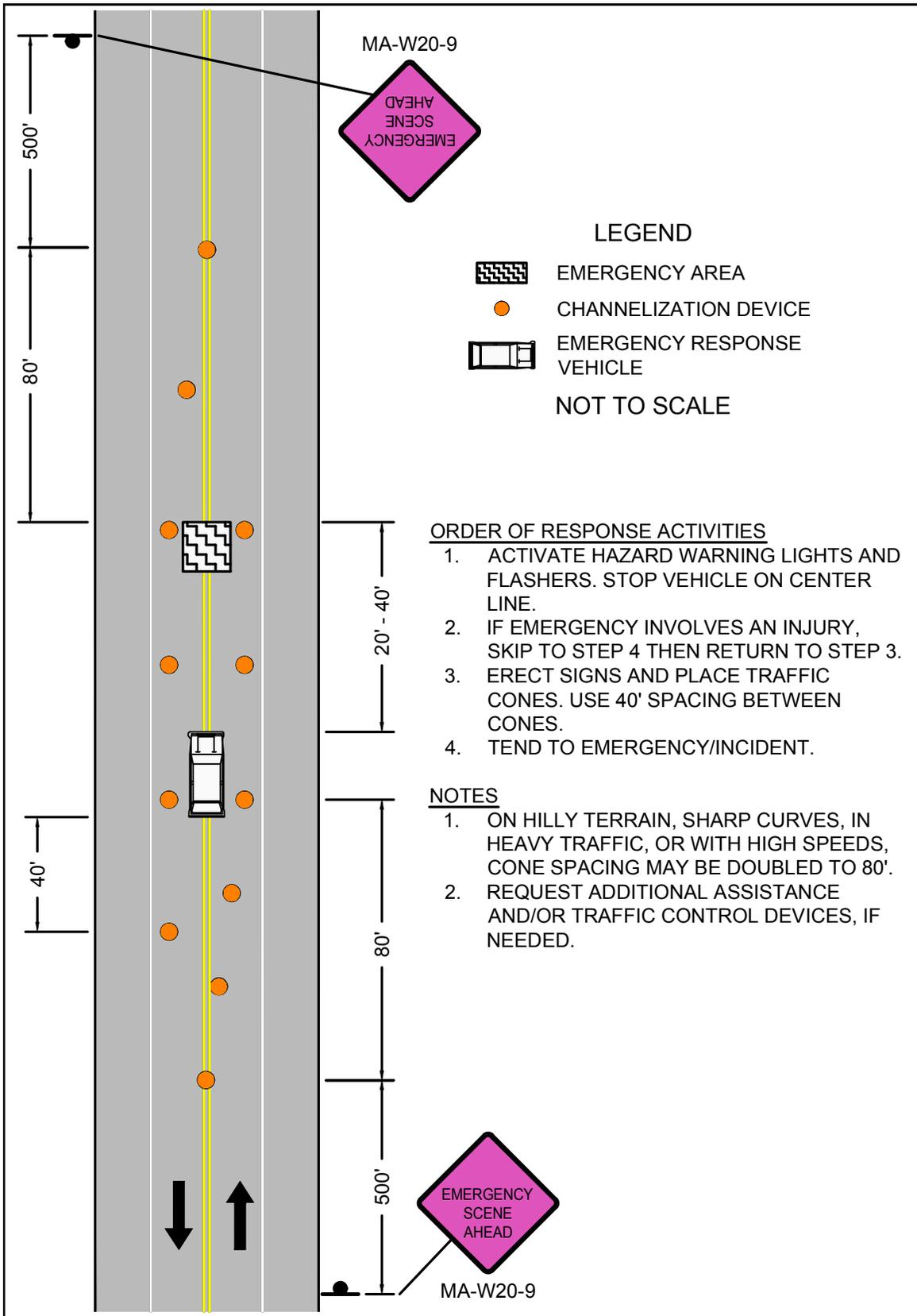

 <p>Massachusetts Department of Transportation Highway Division</p> <p>PAGE 69</p>	<p>Work Zone Safety Standard Details and Drawings</p>	<p>FIGURE 36 EMERGENCY RESPONSE TWO LANE ROADWAY TRAVERSABLE SHOULDER CENTER OF ROADWAY</p>
---	---	---



FIGURE 37
EMERGENCY RESPONSE
MULTILANE DIVIDED ROADWAY
RIGHT LANE

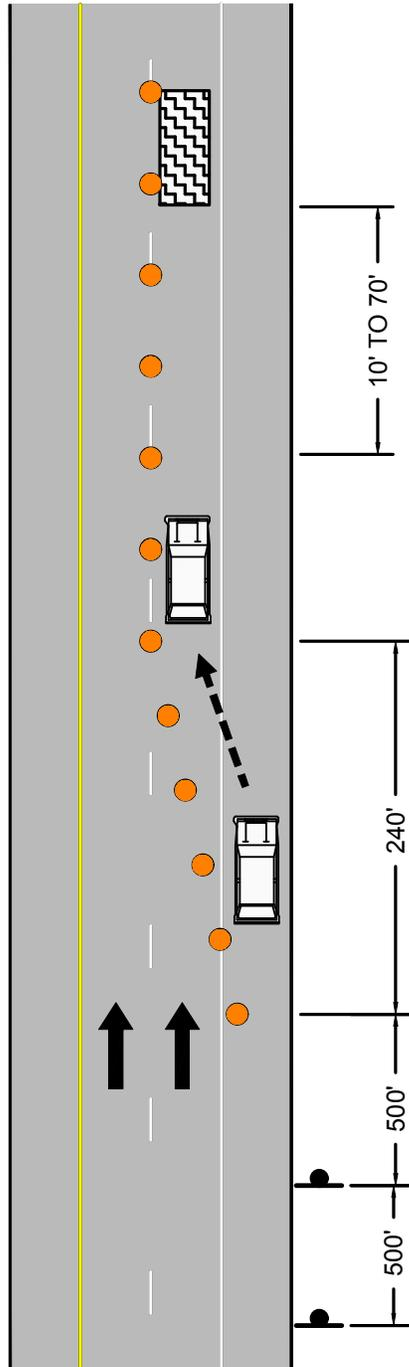

LEGEND

-  EMERGENCY AREA
-  CHANNELIZATION DEVICE
-  EMERGENCY RESPONSE VEHICLE
-  RESPONSE VEHICLE MOVEMENT

NOT TO SCALE

ORDER OF RESPONSE ACTIVITIES

1. ACTIVATE HAZARD WARNING LIGHTS AND FLASHERS. STOP VEHICLE IN BREAKDOWN LANE.
2. IF EMERGENCY INVOLVES AN INJURY, SKIP TO STEP 6 THEN RETURN TO STEP 3.
3. ERECT SIGNS AND PLACE TRAFFIC CONES. USE 40' SPACING BETWEEN CONES.
4. MOVE RESPONSE VEHICLE BEHIND EMERGENCY.
5. PLACE ADDITIONAL CONES.
6. TEND TO EMERGENCY.

NOTES

1. ON HILLY TERRAIN, SHARP CURVES, IN HEAVY TRAFFIC, OR WITH HIGH SPEEDS, CONE SPACING MAY BE DOUBLED TO 80'.
2. REQUEST ADDITIONAL ASSISTANCE AND/OR TRAFFIC CONTROL DEVICES, IF NEEDED.

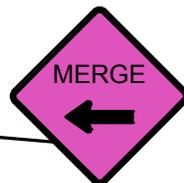

MA-W4-2aL



MA-W20-9

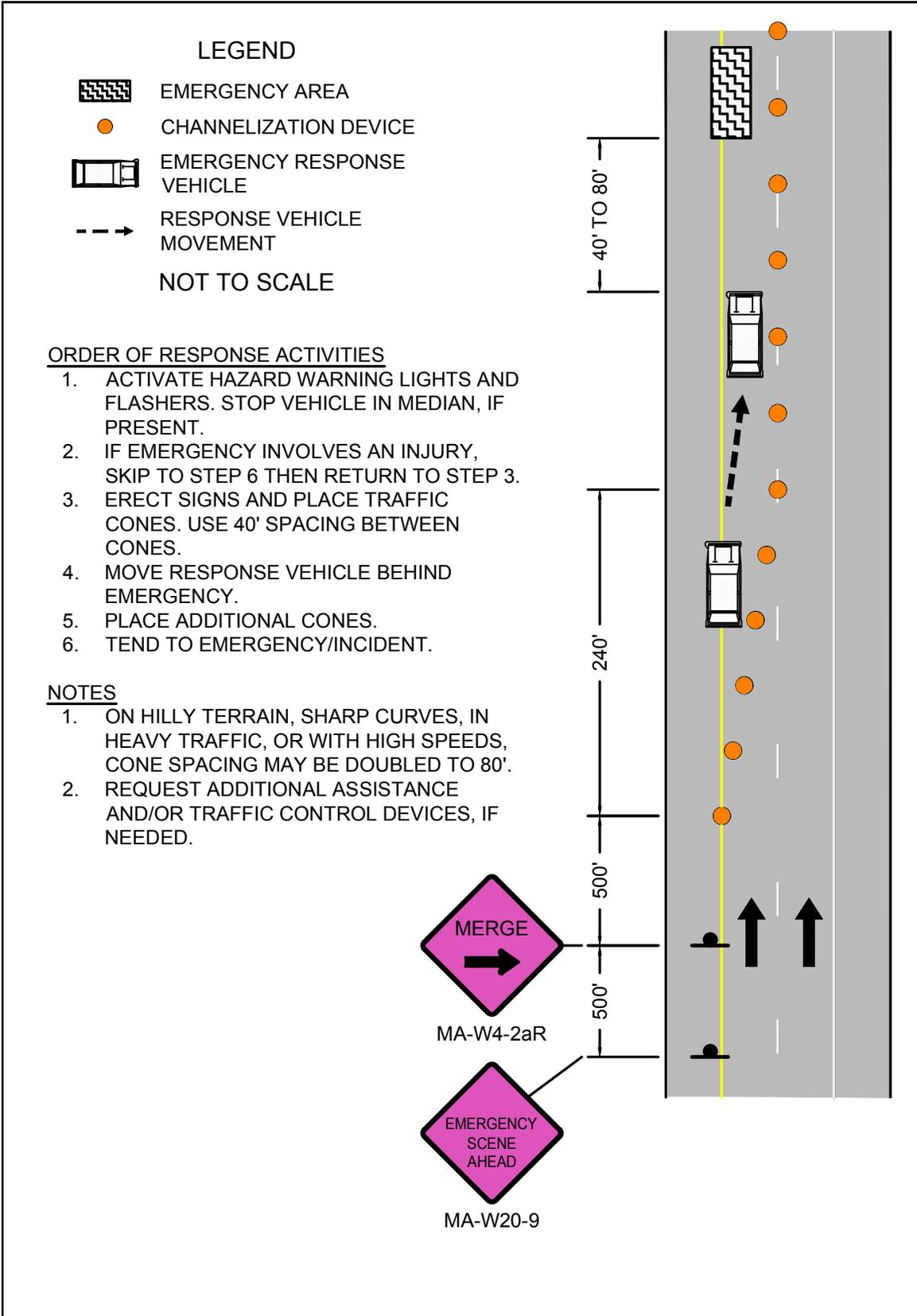
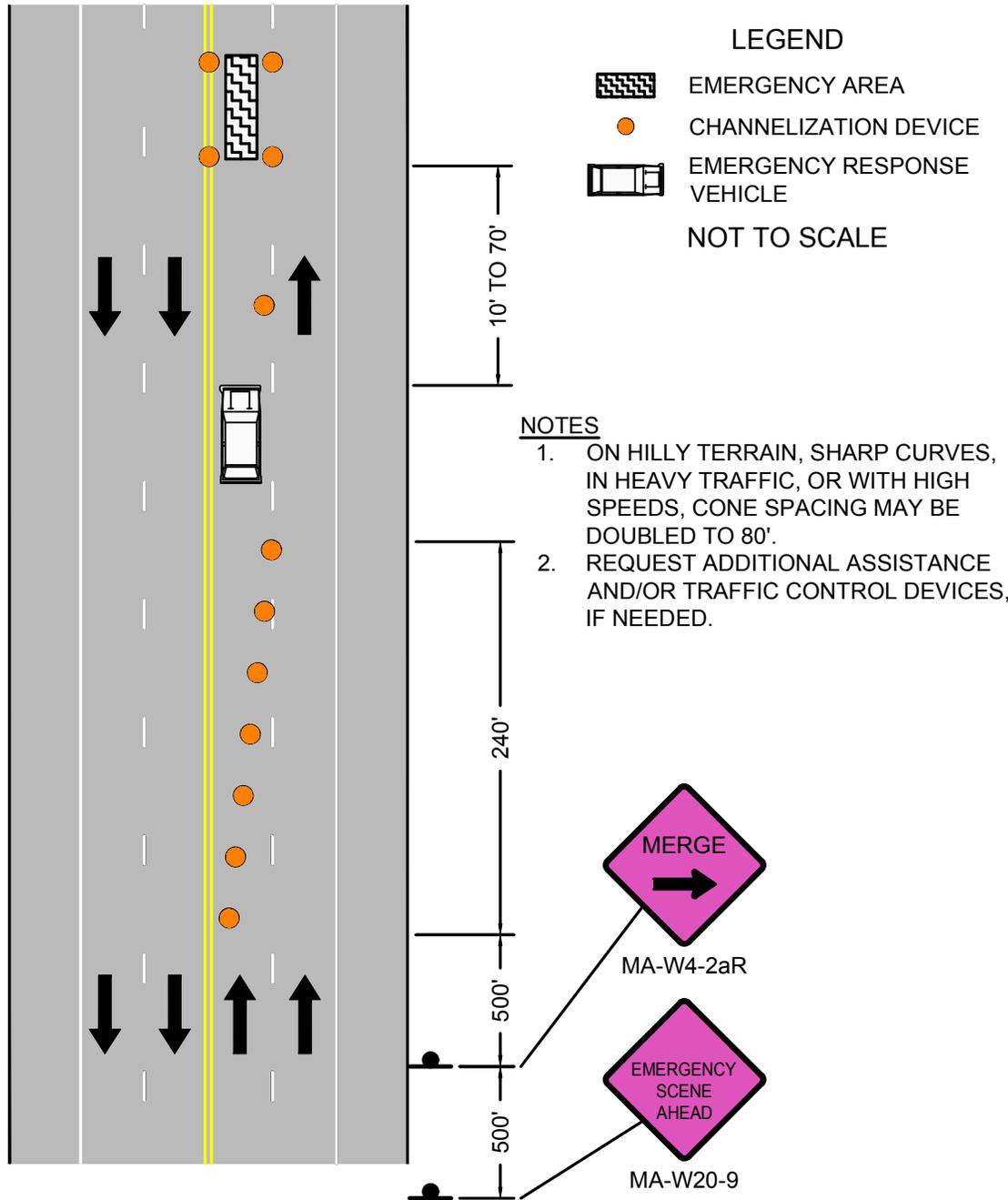

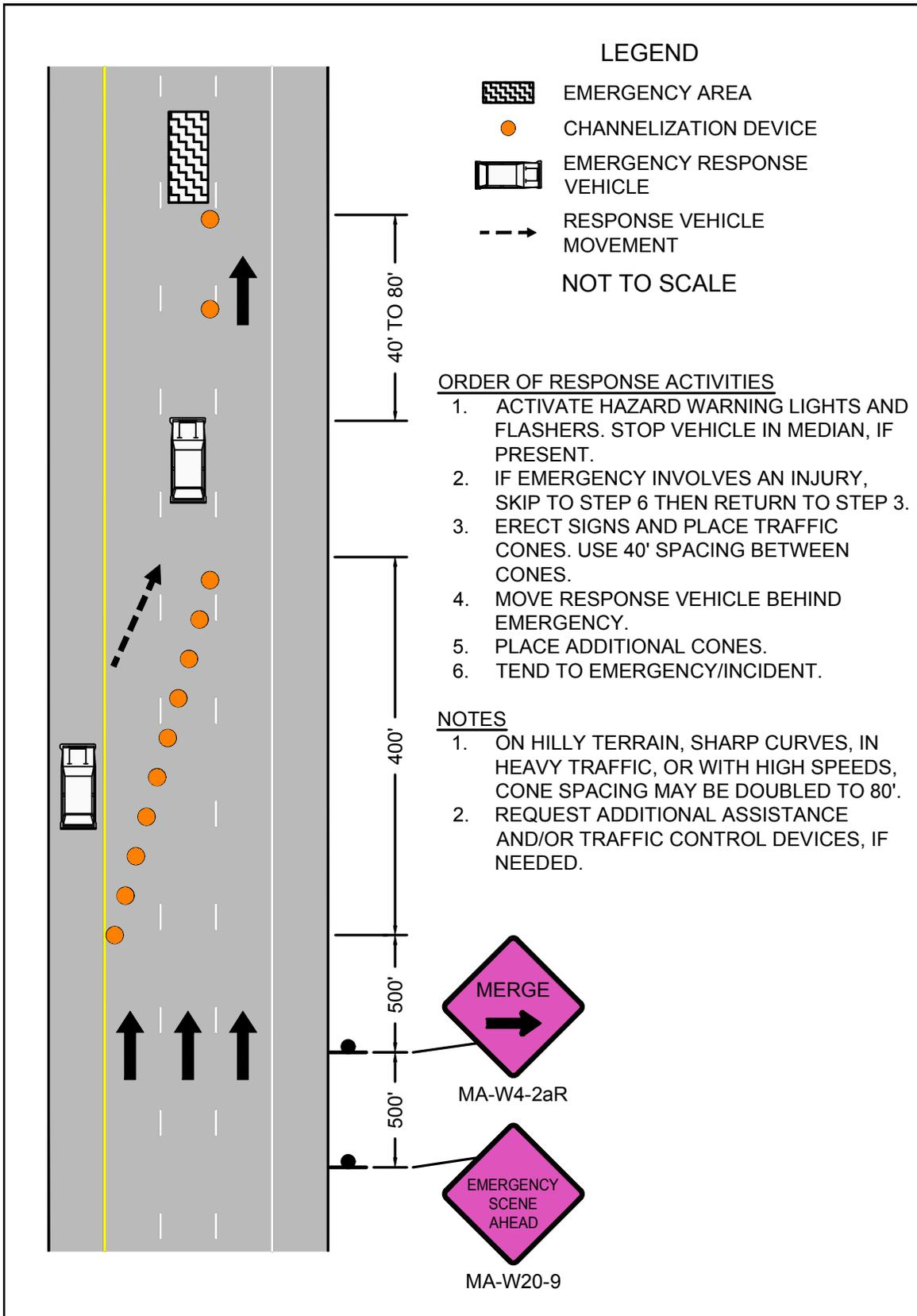

FIGURE 39
EMERGENCY RESPONSE
MULTILANE UNDIVIDED
ROADWAY
LEFT LANE



ORDER OF RESPONSE ACTIVITIES

1. ACTIVATE HAZARD WARNING LIGHTS AND FLASHERS. PULL VEHICLE OVER TO THE RIGHT EDGE OF BREAKDOWN LANE OR SHOULDER OR, IF NOT PRESENT, RIGHT EDGE OF TRAVEL LANE BEFORE STOPPING.
2. IF EMERGENCY INVOLVES AN INJURY, SKIP TO STEP 4 THEN RETURN TO STEP 3.
3. ERECT SIGNS AND PLACE TRAFFIC CONES. USE 40' SPACING BETWEEN CONES.
4. TEND TO EMERGENCY/INCIDENT.



 <p>Massachusetts Department of Transportation Highway Division</p>	<p>Work Zone Safety Standard Details and Drawings</p>	<p>FIGURE 40 EMERGENCY RESPONSE MULTILANE DIVIDED ROADWAY MIDDLE LANE APPROACH FROM LEFT</p>
--	---	---



FIGURE 41
EMERGENCY RESPONSE
MULTILANE DIVIDED ROADWAY
MIDDLE LANE
APPROACH FROM RIGHT

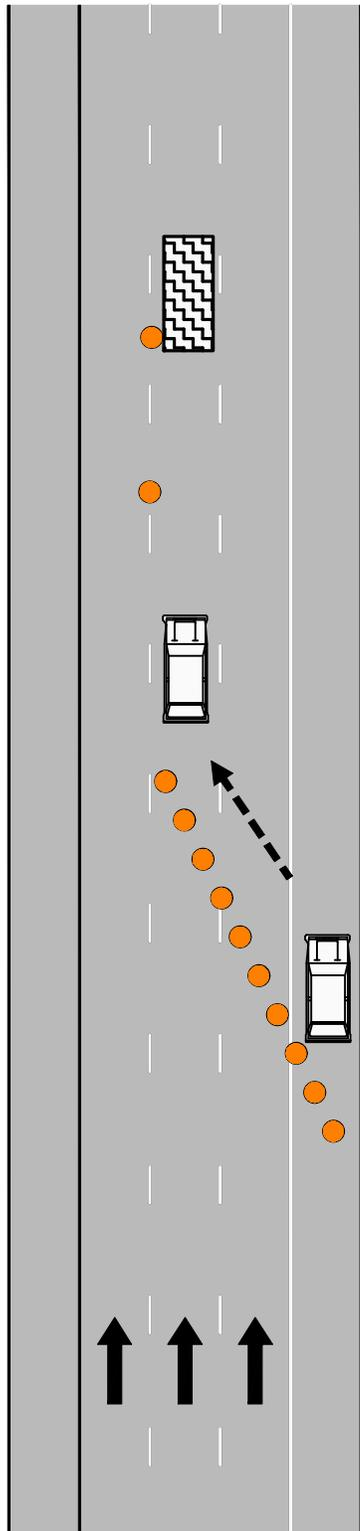

LEGEND

-  EMERGENCY AREA
-  CHANNELIZATION DEVICE
-  EMERGENCY RESPONSE VEHICLE
-  RESPONSE VEHICLE MOVEMENT

NOT TO SCALE

ORDER OF RESPONSE ACTIVITIES

1. ACTIVATE HAZARD WARNING LIGHTS AND FLASHERS. STOP VEHICLE IN BREAKDOWN LANE.
2. IF EMERGENCY INVOLVES AN INJURY, SKIP TO STEP 6 THEN RETURN TO STEP 3.
3. ERECT SIGNS AND PLACE TRAFFIC CONES. USE 40' SPACING BETWEEN CONES.
4. MOVE RESPONSE VEHICLE BEHIND EMERGENCY.
5. PLACE ADDITIONAL CONES.
6. TEND TO EMERGENCY.

NOTES

1. ON HILLY TERRAIN, SHARP CURVES, IN HEAVY TRAFFIC, OR WITH HIGH SPEEDS, CONE SPACING MAY BE DOUBLED TO 80'.
2. REQUEST ADDITIONAL ASSISTANCE AND/OR TRAFFIC CONTROL DEVICES, IF NEEDED.



MA-W4-2aL



MA-W20-9

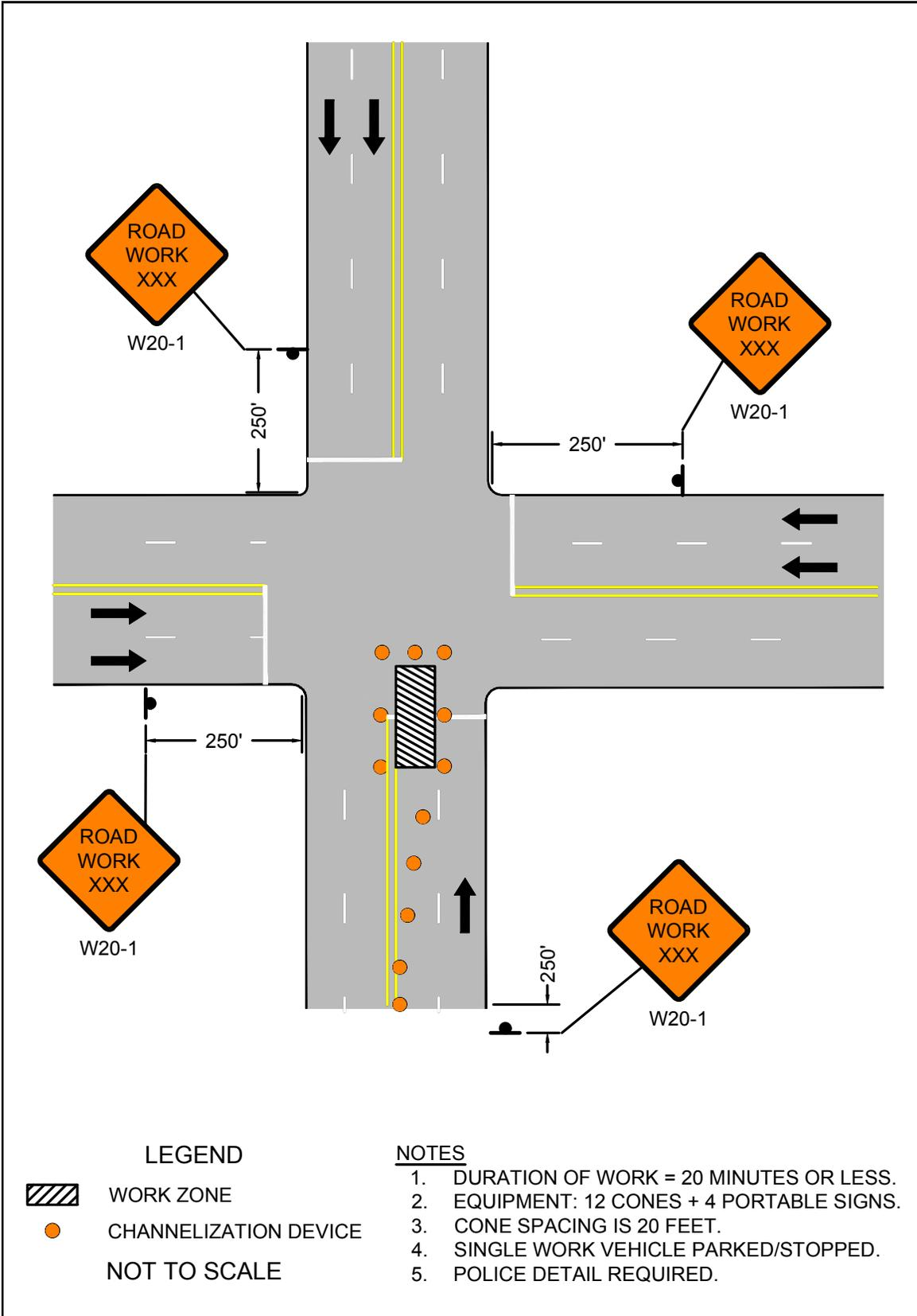



PAGE 76

Work Zone Safety Standard Details and Drawings

FIGURE 43
TRAFFIC SIGNAL REPAIR WORK
TWO LANE UNDIVIDED ROADWAY
ONE LEG OF INTERSECTION

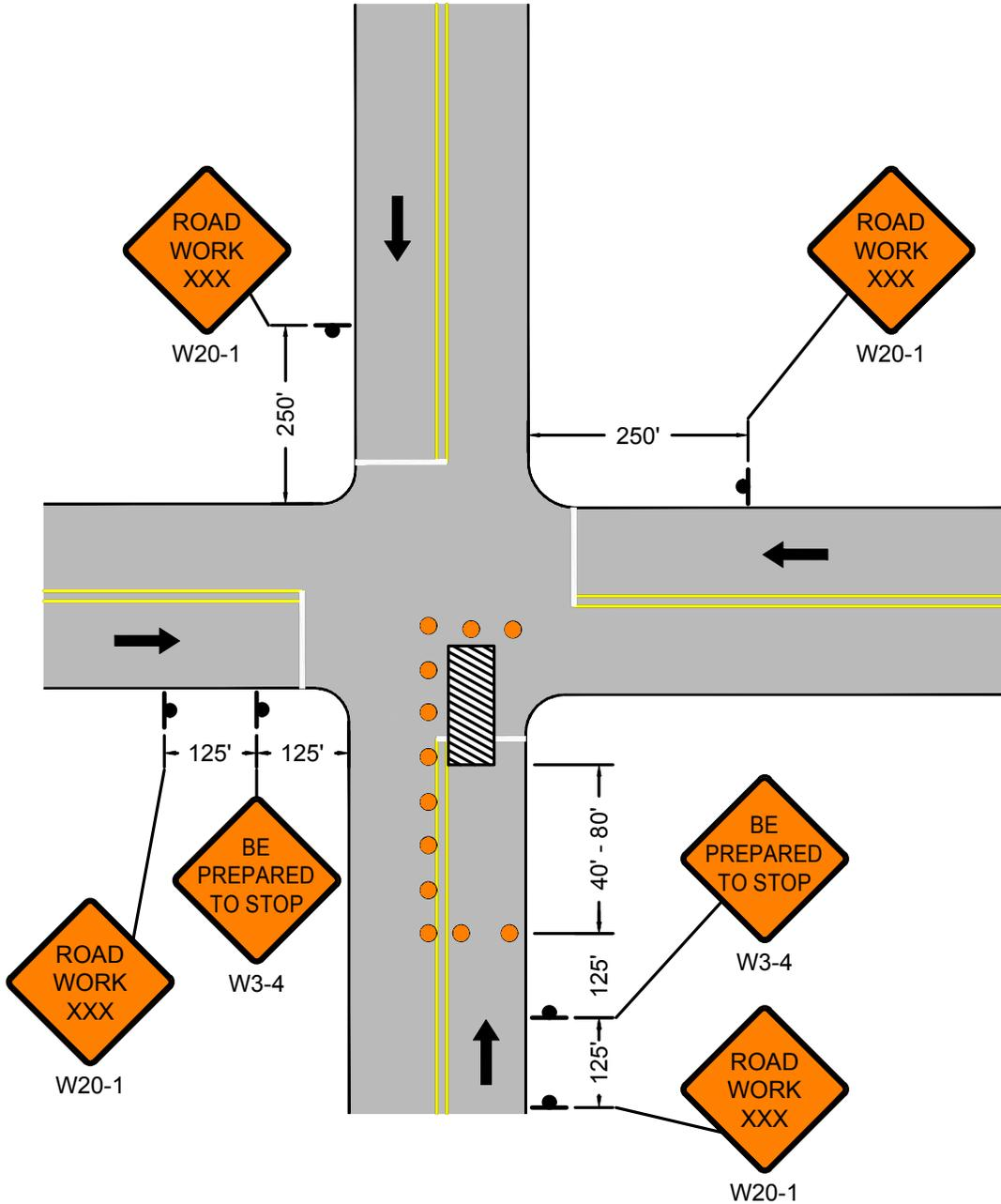

LEGEND

-  WORK ZONE
-  CHANNELIZATION DEVICE
- NOT TO SCALE

NOTES

1. DURATION OF WORK = 20 MINUTES OR LESS.
2. EQUIPMENT: 12 CONES + 6 PORTABLE SIGNS.
3. CONE SPACING IS 20 FEET.
4. SINGLE WORK VEHICLE PARKED/STOPPED.
5. POLICE DETAIL REQUIRED.

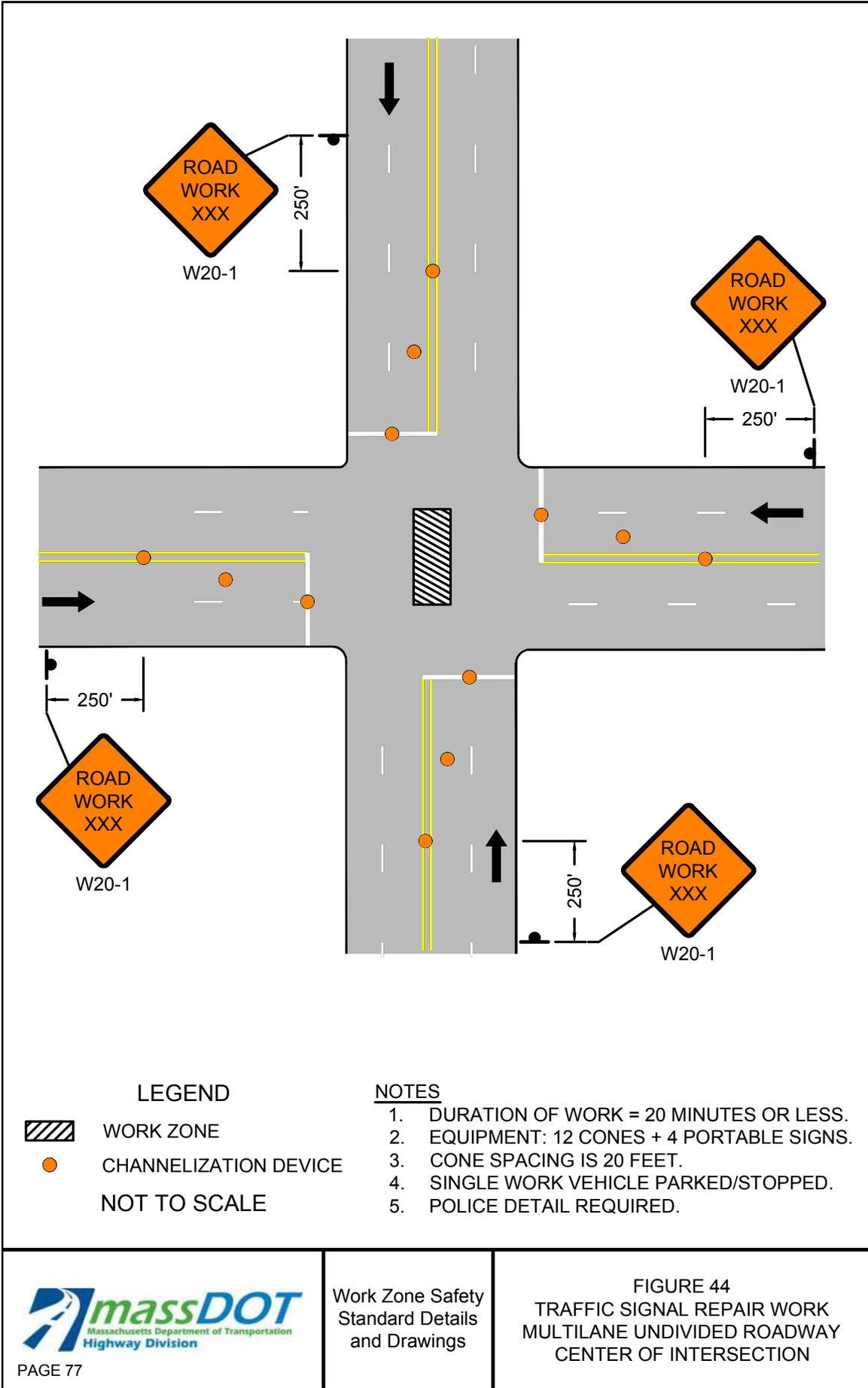
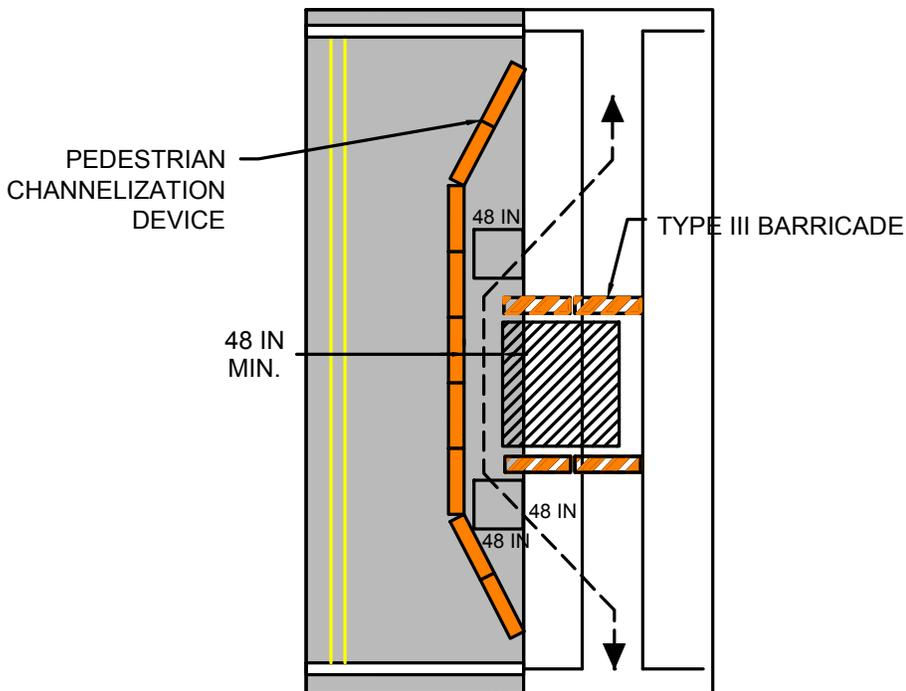

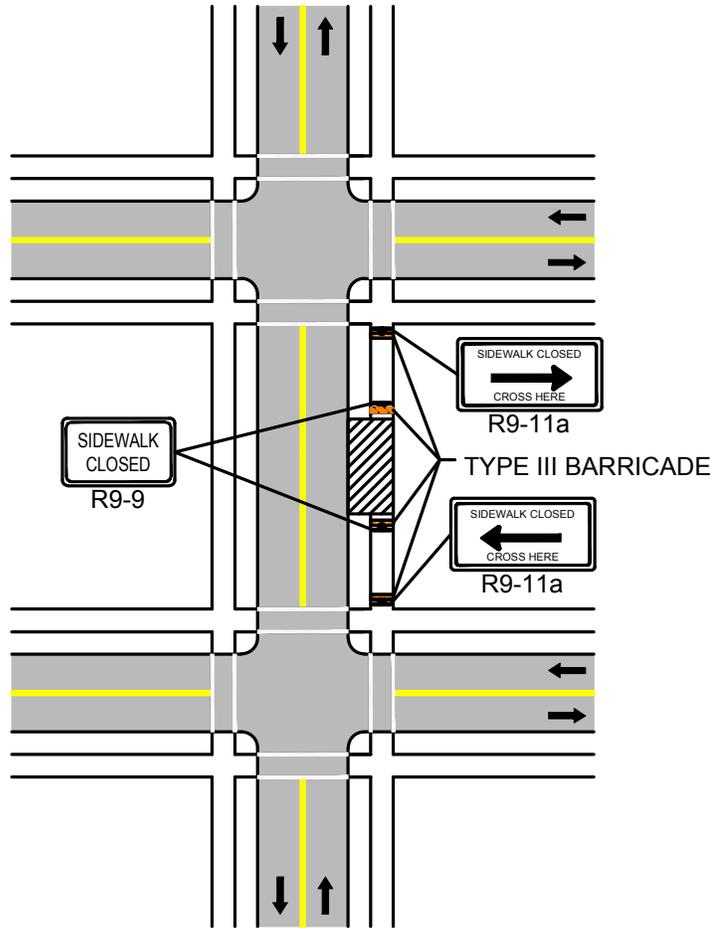

FIGURE 45
PEDESTRIAN BYPASS



NOTES:

1. WHEN EXISTING PEDESTRIAN FACILITIES ARE DISRUPTED, CLOSED, OR RELOCATED IN A TTC ZONE, TEMPORARY FACILITIES SHALL BE PROVIDED AND THEY SHALL BE DETECTABLE AND INCLUDE ACCESSIBILITY FEATURES CONSISTENT WITH THE FEATURES PRESENT IN THE EXISTING PEDESTRIAN FACILITY.
2. A PEDESTRIAN CHANNELIZATION DEVICE THAT IS DETECTABLE BY A PERSON WITH A VISUAL DISABILITY TRAVELING WITH THE AID OF A LONG CANE SHALL BE PLACED ALONG THE FULL LENGTH OF THE TEMPORARY PEDESTRIAN ROUTE.
3. WHEN USED, TEMPORARY RAMPS SHALL COMPLY WITH AMERICANS WITH DISABILITIES ACT.
4. THE ALTERNATE PATHWAY SHOULD HAVE A SMOOTH CONTINUOUS HARD SURFACE FOR THE ENTIRE LENGTH OF THE TEMPORARY PEDESTRIAN FACILITY.
5. THE TEMPORARY SIDEWALK SHOULD BE A MINIMUM OF 4 FEET WIDE. IF THE SIDEWALK EXCEEDS 200 FEET THEN A 5 FOOT BY 5 FOOT PASSING ZONE SHALL BE PROVIDED NEAR THE MID-POINT OF THE CLOSURE.
6. THE PROTECTIVE REQUIREMENTS OF A TTC WORK ZONE MAY HAVE AN IMPACT IN DETERMINING THE NEED FOR TEMPORARY TRAFFIC BARRIERS AND THEIR USE IN PROVIDING PEDESTRIAN DELINEATION SHOULD BE BASED ON ENGINEERING JUDGMENT.
7. ON-DEMAND PEDESTRIAN ASSISTANCE PERSONNEL TO ASSIST WITH NAVIGATION AROUND THE CLOSURE/WORK AREA MAY BE CONSIDERED AS AN OPTION IN PLACE OF PROVIDING ADA/AAB DEVICES FOR WORK FOR CLOSURES LASTING 4 HOURS OR LESS.
8. CONTROLS ONLY FOR PEDESTRIAN TRAFFIC ARE SHOWN; VEHICULAR TRAFFIC SHOULD BE HANDLED AS SHOWN ELSEWHERE. THESE DETAILS ARE USED IN CONJUNCTION WITH THE PROPOSED LANE CLOSURE DETAILS AND DURING CONSTRUCTION STAGING, AS DETERMINED BY THE ENGINEER.



NOTES:

1. CLOSURE OF A SIDEWALK FACILITY SHALL CONSTITUTE THE PROVISION FOR MANAGING PEDESTRIAN TRAFFIC AND ACCOMMODATING ALL USERS. IF THE EXISTING PEDESTRIAN ACCESS ROUTE(S) CAN BE TEMPORARILY RELOCATED ALONG THE EXISTING SIDEWALK , AND SAID FACILITY PROVIDES A MINIMUM WIDTH OF 48-INCHES OF SOLID, SMOOTH UNOBSTRUCTED SURFACE, THEN NO DETOURING OF THE ROUTE SHALL BE REQUIRED. DELINEATION OF THE WORK AREA IS STILL REQUIRED.
2. IF IT IS NECESSARY TO DIVERT PEDESTRIAN TRAFFIC TO AN ALTERNATE ROUTE ACROSS THE ROADWAY FROM THE EXISTING FACILITY, THE FIGURE ABOVE SHALL BE FOLLOWED TO PROVIDE ADEQUATE DIRECTION TO PEDESTRIANS. ALTERNATE ROUTE SHALL PROVIDE THE SAME LEVEL OF ACCOMMODATION AS THE FACILITY THAT IS BEING DETOURED AND RETAIN ADA COMPLIANCE IN ITS ENTIRETY.
3. FOR EMERGENCY OR SHORT-DURATION SIDEWALK CLOSURES OF 4-HOURS OR LESS, IT IS OPTIONAL TO HAVE ON-DEMAND PEDESTRIAN ASSISTANCE PERSONNEL AVAILABLE AT ALL TIMES DURING THE CLOSURE TO ASSIST THOSE MOBILITY CHALLENGED PERSONS WHO REQUIRE ADDITIONAL ASSISTANCE TO SAFELY NAVIGATE AROUND THE WORK AREA IN LIEU OF A FULL DETOUR.





PAGE 80

Work Zone Safety
Standard Details
and Drawings

STATIONARY OPERATIONS
BIKE LANE CLOSURE

POSTED SPEED LIMIT (MPH)	SPACING FOR BIKE ADVANCE WARNING SIGNS (FT) (A,B))	CHANNELIZATION DEVICES (DRUMS OR CONES)			
		TRANSITION LENGTH (L/3)	BUFFER ZONE LENGTH (FT)	DEVICE SPACING (FT)	MIN # OF DEVICES*
25-40	150 / 150	100	305	20	45
45-55	150 / 150	220	495	40	35
60-65	150 / 150	260	645	40	40

* NUMBER OF DEVICES BASED ON 400 FT WORK ZONE.

NOTES

1. DETAIL SHALL BE USED IN CONJUNCTION WITH THE PROPOSED LANE CLOSURE DETAILS. SIGNING SHOWN ONLY FOR BIKE TRAFFIC. FOLLOW ALL OTHER RELEVANT DETAILS FOR TTC DEVICES FOR VEHICULAR TRAFFIC.
2. ** SIGN SHALL BE USED ONLY IF THERE IS A MARKED BIKE LANE.
3. *** SIGN SHALL BE USED ONLY IF THERE IS NO MARKED BIKE LANE.

LEGEND

-  WORK ZONE
-  CHANNELIZATION DEVICE
-  FLASHING ARROW BOARD
-  PORTABLE CHANGEABLE MESSAGE SIGN
-  TRUCK MOUNTED ATTENUATOR
-  RADAR SPEED FEEDBACK BOARD
-  POLICE DETAIL OR UNIFORMED FLAGGER
-  TEMPORARY PORTABLE RUMBLE STRIP
-  TYPE III BARRICADE

NOT TO SCALE

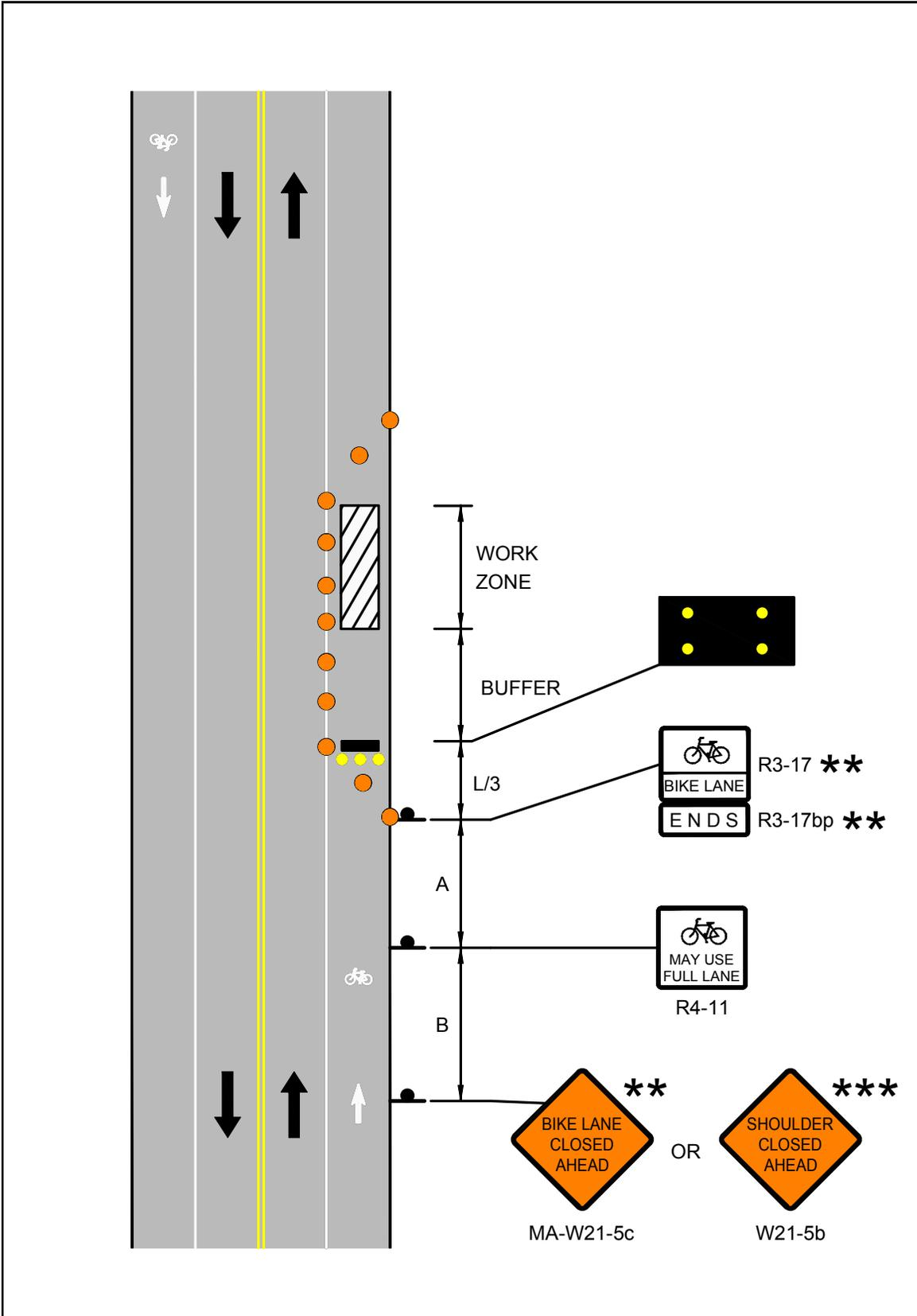

 <p>PAGE 81</p>	<p>Work Zone Safety Standard Details and Drawings</p>	<p>FIGURE 48 STATIONARY OPERATIONS BIKE LANE CLOSURE</p>
--	---	--



Safety is everyone's business

Rev. June, 2017

RUMBLE STRIP DETAILS

TYPE C
CONTINUOUS SINUSOIDAL
RUMBLE STRIP

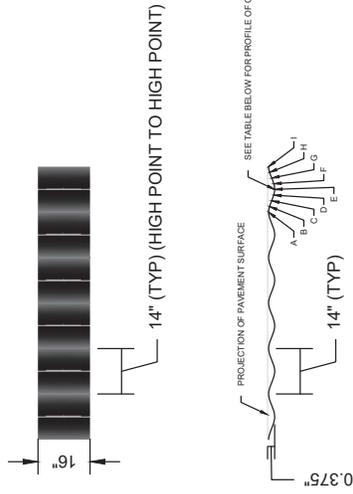

TYPE B
CYLINDER RUMBLE STRIP
(BICYCLE TRAVEL PERMITTED)

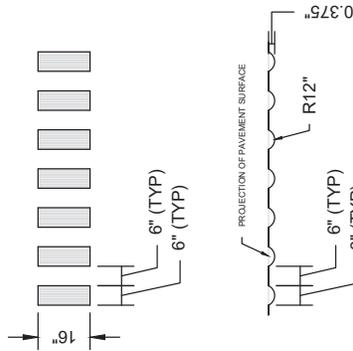

TYPE A
CYLINDER RUMBLE STRIP
(BICYCLE TRAVEL PROHIBITED)

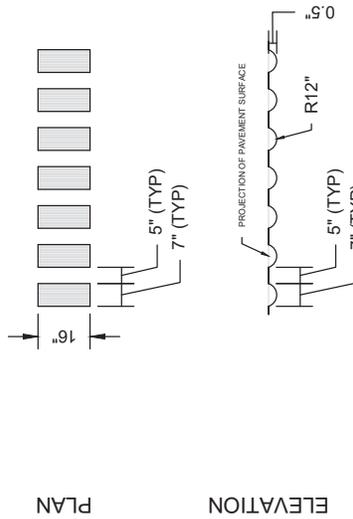

- NOTES:**
1. NOT TO SCALE. SOME LINE WORK EXAGGERATED FOR CLARITY.
 2. SEE PLANS FOR LOCATION(S) AND START AND END STATIONS FOR ALL RUMBLE STRIP INSTALLATIONS.
 3. HIGH POINT OF SINUSOIDAL RUMBLE STRIP LOCATED $\frac{1}{16}$ " BELOW PAVEMENT SURFACE.

DESIGN OF CURVE PROFILE FOR SINUSOIDAL RUMBLE STRIP

POINT	A	B	C	D	E	F	G	H	I
DEPTH FROM PAVEMENT SURFACE (IN.)	$\frac{1}{16}$	$\frac{1}{8}$	$\frac{7}{32}$	$\frac{11}{32}$	$\frac{3}{8}$	$\frac{11}{32}$	$\frac{7}{32}$	$\frac{1}{8}$	$\frac{1}{16}$
DISTANCE FROM HIGH POINT "A" (IN.)	0	1.75	3.5	5.25	7	8.75	10.5	12.25	14

massDOT
Massachusetts Department of Transportation
Highway Division

TRAFFIC & SAFETY STANDARDS
SECTION 860

RUMBLE STRIP DETAILS

D-T-E OF ISSUE: 2020

DR- ING NUMBER: **XXX.X.X**

DOCUMENT A00820

**Massachusetts Department of Transportation
Conditions of Custody**

REQUEST FOR RELEASE OF MASSDOT AUTOCAD FILES FORM

(Only to be used following award of contract)

City/Town: WEST SPRINGFIELD - CHICOPEE

Project File Number: 612097

Contract Number: 129070

Project Description: Pavement and Bridge Preservation on I-91

All AutoCAD files are provided solely as a courtesy to facilitate public access to information. MassDOT attempts to provide current and accurate information but cannot guarantee so. MassDOT provides such documents, files or other data "as is" without any warranty of any kind, either expressed or implied, including but not limited to, accuracy, reliability, omissions, completeness and currentness. The Commonwealth of Massachusetts and its Consultants shall not be liable for any claim for damages, including lost profits or other consequential, exemplary, incidental, indirect or special damages, relating in any way to the documents, files or other data accessible from this file, including, but not limited to, claims arising out of or related to electronic access or transmission of data or viruses. Because data stored on electronic media can deteriorate undetected or be modified without our knowledge, MassDOT cannot be held liable for its completeness or correctness. MassDOT makes no representation as to the compatibility of these files beyond the version of the stated CAD software.

By signing this form, I agree that it shall be my responsibility to reconcile this electronic data with the conformed contract documents, and that only the conformed contract documents shall be regarded as legal documents for this Project. I understand that this authorization does not give me the right to distribute the files. I agree to the terms above and wish to receive the AutoCAD files.

This signed form shall be emailed to the Highway Design Engineer at the MassDOT -Highway Division at the following email address:

DOTHighwayDesign@dot.state.ma.us

Attn: AutoCAD Files

Name of person requesting AutoCAD files: _____

Affiliation/Company: _____

Address: _____

Telephone number: _____

Email address: _____

Signature/Date: _____

THIS PAGE IS INTENTIONALLY LEFT BLANK

DOCUMENT A00850

MASSACHUSETTS WETLANDS PROTECTION ACT

Request for Determination

THIS PAGE INTENTIONALLY LEFT BLANK



Maura Healey, Governor
Kimberley Driscoll, Lieutenant Governor
Monica Tibbitts-Nutt, Secretary & CEO
Jonathan L. Gulliver, Highway Administrator



Return Receipt Requested

August 5, 2024

West Springfield Conservation Commission
26 Central Street #12
West Springfield, MA 01089

Re: Request for Determination of
Applicability
West Springfield/Chicopee – Interstate
Maintenance and Related Work on I-91
Project File #612097

Dear Commission Members:

Please find enclosed a Request for Determination of Applicability for *West Springfield/Chicopee – Interstate Maintenance and Related Work on I-91* in the Town of West Springfield. This project is being filed under the Massachusetts Wetlands Protection Act, M.G.L. Chapter 131 § 40, and its regulations, 310 CMR 10.00. No findings under Town Bylaws, including any Wetland Bylaws, are requested.

The MassDOT Highway Division is an agency of State Government and as such is exempt from local Conservation Commission by-laws and fees. For MassDOT to provide advertising payment, the newspaper must directly bill the Massachusetts Department of Transportation, at the address shown below.

As indicated under 310 CMR: 10:05(3)(b)1, a Determination of Applicability shall be issued within 21 days after the date of receipt of an RDA. If within the 21 days you have questions or would like to schedule a site visit, please contact Billie Li, District Environmental Engineer, at (857)-286-3311.

Sincerely,

Patricia A. Leavenworth, P.E.
District Highway Director

BL *BL*

BL/
C- PKS (w/encl.) *PKS*
DEP-WERO (w/encl.)
Encl.

811 North King Street, Northampton, MA 01060
Tel: (857) 368-2000, Fax: (857) 368-0200
mass.gov/massdot



Massachusetts Department of Environmental Protection
 Bureau of Water Resources - Wetlands

WPA Form 1- Request for Determination of Applicability West Springfield Municipality
 Massachusetts Wetlands Protection Act M.G.L. c. 131, §40

A. General Information

Important:
 When filling out forms on the computer, use only the tab key to move your cursor - do not use the return key.



1. Applicant:

<u>Patricia</u> First Name	<u>Leavenworth</u> Last Name
<u>811 N. King Street</u> Address	
<u>Northampton</u> City/Town	<u>MA</u> State
	<u>01060</u> Zip Code
<u></u> Phone Number	<u></u> Email Address

2. Property Owner (if different from Applicant):

<u></u> First Name	<u></u> Last Name
<u></u> Address	
<u></u> City/Town	<u></u> State
	<u></u> Zip Code
<u></u> Phone Number	<u></u> Email Address (if known)

3. Representative (if any)

<u>Billie</u> First Name	<u>Li</u> Last Name
<u>MassDOT - District 2</u> Company Name	
<u>811 N. King Street</u> Address	
<u>Northampton</u> City/Town	<u>MA</u> State
	<u>01060</u> Zip Code
<u>857-286-3311</u> Phone Number	<u>Billie.m.li@dot.state.ma.us</u> Email Address (if known)

B. Project Description

1. a. Project Location (use maps and plans to identify the location of the area subject to this request):

<u>I-91</u> Street Address	<u>West Springfield</u> City/Town
<u>42.13571</u> Latitude (Decimal Degrees Format with 5 digits after decimal e.g. XX.XXXXX)	<u>-72.61524</u> Longitude (Decimal Degrees Format with 5 digits after decimal e.g. -XX.XXXXX)
<u></u> Assessors' Map Number	<u></u> Assessors' Lot/Parcel Number

[How to find Latitude and Longitude](#)

[and how to convert to decimal degrees](#)

b. Area Description (use additional paper, if necessary):
See Attachment A

c. Plan and/or Map Reference(s): (use additional paper if necessary)

<u>See Plans - Attachment C</u> Title	<u>As Noted</u> Date
<u>See Maps - Attachment D</u> Title	<u>7/17/2024</u> Date



Massachusetts Department of Environmental Protection

Bureau of Water Resources - Wetlands

WPA Form 1- Request for Determination of Applicability

West Springfield

Massachusetts Wetlands Protection Act M.G.L. c. 131, §40

Municipality

B. Project Description (cont.)

2. a. Activity/Work Description (use additional paper and/or provide plan(s) of Activity, if necessary):

See Attachment A

b. Identify provisions of the Wetlands Protection Act or regulations which may exempt the applicant from having to file a Notice of Intent for all or part of the described work (use additional paper, if necessary).

See Attachment B

3. a. If this application is a Request for Determination of Scope of Alternatives for work in the Riverfront Area, indicate the one classification below that best describes the project.

- Single family house on a lot recorded on or before 8/1/96
- Single family house on a lot recorded after 8/1/96
- Expansion of an existing structure on a lot recorded after 8/1/96
- Project, other than a single-family house or public project, where the applicant owned the lot before 8/7/96
- New agriculture or aquaculture project
- Public project where funds were appropriated prior to 8/7/96
- Project on a lot shown on an approved, definitive subdivision plan where there is a recorded deed restriction limiting total alteration of the Riverfront Area for the entire subdivision
- Residential subdivision; institutional, industrial, or commercial project
- Municipal project
- District, county, state, or federal government project
- Project required to evaluate off-site alternatives in more than one municipality in an Environmental Impact Report under MEPA or in an alternatives analysis pursuant to an application for a 404 permit from the U.S. Army Corps of Engineers or 401 Water Quality Certification from the Department of Environmental Protection.

b. Provide evidence (e.g., record of date subdivision lot was recorded) supporting the classification above (use additional paper and/or attach appropriate documents, if necessary.)



Massachusetts Department of Environmental Protection
Bureau of Water Resources - Wetlands

WPA Form 1- Request for Determination of Applicability West Springfield
Massachusetts Wetlands Protection Act M.G.L. c. 131, §40 Municipality

C. Determinations

1. I request the West Springfield make the following determination(s). Check any that apply:
Conservation Commission

- a. whether the **area** depicted on plan(s) and/or map(s) referenced above is an area subject to jurisdiction of the Wetlands Protection Act.
- b. whether the **boundaries** of resource area(s) depicted on plan(s) and/or map(s) referenced above are accurately delineated.
- c. whether the **Activities** depicted on plan(s) referenced above is subject to the Wetlands Protection Act and its regulations.
- d. whether the area and/or Activities depicted on plan(s) referenced above is subject to the jurisdiction of any **municipal wetlands' ordinance** or **bylaw** of:

Name of Municipality

- e. whether the following **scope of alternatives** is adequate for Activities in the Riverfront Area as depicted on referenced plan(s).
- _____

D. Signatures and Submittal Requirements

I hereby certify under the penalties of perjury that the foregoing Request for Determination of Applicability and accompanying plans, documents, and supporting data are true and complete to the best of my knowledge.

I further certify that the property owner, if different from the applicant, and the appropriate DEP Regional Office were sent a complete copy of this Request (including all appropriate documentation) simultaneously with the submittal of this Request to the Conservation Commission.

Failure by the applicant to send copies in a timely manner may result in dismissal of the Request for Determination of Applicability.

Signatures:

I also understand that notification of this Request will be placed in a local newspaper at my expense in accordance with Section 10.05(3)(b)(1) of the Wetlands Protection Act regulations.

Patricia A. Leavenworth

Signature of Applicant

08/05/2024

Date

Billie Li

Signature of Representative (if any)

08/05/2024

Date



Maura Healey, Governor
Kimberley Driscoll, Lieutenant Governor
Monica Tibbitts-Nutt, Secretary & CEO
Jonathan L. Gulliver, Highway Administrator



Table of Attachments

Attachment A – Project Description

Attachment B – Wetlands Protection Act Provisions for Exemption

Attachment C – Design Plans

Attachment D – Maps



Maura Healey, Governor
 Kimberley Driscoll, Lieutenant Governor
 Monica Tibbits-Nutt, Secretary & CEO
 Jonathan L. Gulliver, Highway Administrator



Attachment A – Project Description

Area Description

The project is located on I-91, from Mile Marker 8.5 to 10.5 and includes the Connecticut River Bridge. The project limits within the Town of West Springfield are from the town line on the Connecticut River Bridge to Mile Marker 10.5. All proposed work is within the existing State Highway Layout. The area of work includes 200-Foot Riverfront Area, Bordering Land Subject to Flooding (FEMA Zone AE & X) and the Buffer Zone of Bordering Vegetated Wetlands.

Activity & Description of Work

The project Scope of Work includes roadway & bridge deck resurfacing, bridge deck repairs, installation of asphalt berms, cleaning of paved waterways, installation of new paved waterway connectors, clearing roadway side slopes, removal of build-up material on shoulders to restore drainage, adjusting and/or rebuilding drainage structures, and selective tree trimming. Erosion and sedimentation control measures will be installed prior to construction activities and removed upon completion and stabilization of the work areas. Items that may be included as needed include guardrail repairs, traffic striping and other incidental items required to complete the work.

Within the Buffer Zone of Bordering Vegetated Wetlands, the activities are limited to roadway resurfacing within the existing limits of pavement, clearing roadway side slopes & removal of build-up material on shoulders to restore drainage, selective tree trimming, cleaning of the paved waterway, adjusting and/or rebuilding drainage structures, and the installation of erosion and sedimentation control measures. In addition to cleaning the paved waterway, four paved channels approximately 15 feet long by 4-feet wide will be constructed connecting the edge of the road to the paved waterway in an effort to improve stormwater conveyance (See Attachment C – Design Plans, for more details). Two of these proposed connections are within the Buffer Zone. The construction of the paved connections will not result in the creation of new discharge points to the resource area.

Within the 200-Foot Riverfront Area of both the Connecticut river and Goldine Brook, the activities include roadway & bridge deck resurfacing, bridge deck repairs, selective tree trimming and vegetation cutting for safety & maintenance, adjusting and/or rebuilding drainage structures, and the use of erosion and sedimentation control measures. The 200-Foot Riverfront Area also coincides with Bordering Land Subject to

Flooding (adjacent to Connecticut River only), Bordering Vegetative Wetlands and its Buffer Zone. Within the overlapping resource areas, work will remain within the existing pavement limits and will not result in an increase to impervious area or alterations to the existing drainage system.

Work in the area that appears to be mapped as Bordering Land Subject to Flooding will include all activities occurring in the 200-foot Riverfront Area. Since the occurrence of these activities will be on the existing bridge and elevated roadway surface, no impacts to flood storage capacity of the BLSF will result. In addition, due to the limited nature of the work and the significant elevation difference between the bridge deck and the resource areas located below, it is anticipated that the work will not have any adverse effects.



Maura Healey, Governor
 Kimberley Driscoll, Lieutenant Governor
 Monica Tibbitts-Nutt, Secretary & CEO
 Jonathan L. Gulliver, Highway Administrator



Attachment B – Wetlands Protection Act Provisions for Exemption

310 CMR 10.02(2)(a) Activities Within the Areas Subject to Protection under M.G.L. c. 131, § 40.

Any activity proposed or undertaken within an area specified in 310 CMR 10.02(1), which will remove, fill, dredge or alter that area, is subject to Regulation under M.G.L. c. 131, § 40 and requires the filing of a Notice of Intent except:

1. Minor activities within the riverfront area meeting the requirement of 310 CMR 10.02(20)(b) 1. And 2.; and
2. Activities conducted to maintain, repair or replace, but not substantially change or enlarge an existing lawfully located structure or facility used in the service of the public and used to provide electric, gas, water, sewer, telephone, telegraph and other communication services, provided said work utilizes the best practical measures to avoid or minimize impacts to wetland resource areas outside the footprint of said structure or facility. A project proponent claiming that work to remove, fill, dredge or alter an area specified in 310 CMR 10.02(2) does not require the filing of a Notice of Intent has the burden of establishing that the work is not subject to Regulation under M.G.L. c. 131, § 40.

310 CMR 10.02(2)(b) Activities Within the Buffer Zone.

Any activity other than minor activities identified in 310 CMR 10.02(2)(b)2. proposed or undertaken within 100 feet of an area specified in 310 CMR 10.02(1)(a) (hereinafter called the Buffer Zone) which, in the judgment of the issuing authority, will alter an Area Subject to Protection under M.G.L. c. 131, § 40 is subject to regulation under M.G.L. c. 131, § 40 and requires the filing of a Notice of Intent. (See also 310 CMR 10.05(3)(a)2.). The areas subject to jurisdiction identified in 310 CMR 10.02(1)(b) through (f) do not have a buffer zone.

1. Minor activities, as described in 310 CMR 10.02(2)(b)2., within the buffer zone and outside any areas specified in 310 CMR 10.02(1)(a) through (e) are not otherwise subject to regulation under M.G.L. c. 131, § 40 provided that the work is performed: solely within the buffer zone, as prescribed in 310 CMR 10.02(2)(b)2.a. through q., in a manner so as to reduce the potential for any adverse impacts to the resource area during construction, and with post-construction measures implemented to stabilize any disturbed areas. Factors to consider when measuring the potential for adverse impacts to resource areas include the extent of the work, the proximity to the resource area, the need for erosion controls, and the measures employed to prevent adverse impacts to resource areas during and following the work.
2. The following minor activities, provided that they comply with 310 CMR 10.02(2)(b) 1., are not otherwise subject to regulation under M.G.L. c. 131, § 40:

...



Maura Healey, Governor
 Kimberley Driscoll, Lieutenant Governor
 Monica Tibbitts-Nutt, Secretary & CEO
 Jonathan L. Gulliver, Highway Administrator



c. Vista pruning, provided the activity is located more than 50 feet from the mean annual high water line within a Riverfront Area or from Bordering Vegetated Wetland, whichever is farther. (Pruning of landscaped areas is not subject to jurisdiction under 310 CMR 10.00);

...

g. Activities that are temporary in nature, have negligible impacts, and are necessary for planning and design purposes (e.g., installation of monitoring wells, exploratory borings, sediment sampling and surveying and percolation tests for septic systems provided that resource areas are not crossed for site access);

...

n. Vegetation cutting for road safety maintenance, limited to the following:

i. Removal of diseased or damaged trees or branches that pose an immediate and substantial threat to driver safety from falling into the roadway;

ii. Removal of shrubbery or branches to maintain clear guardrails; such removal shall extend no further than six feet from the rear of the guardrail;

iii. Removal of shrubbery or branches to maintain sight distances at existing intersections; such removal shall be no farther than five feet beyond the "sight triangles" established according to practices set forth in American Association of State Highway and Transportation Officials (AASHTO) A Policy on Geometric Design of Highways and Streets, 2011, 6th edition, and such removal is a minimum of ten feet from a resource area, other than Riverfront Area; and

iv. Removal of shrubbery, branches, or other vegetation required to maintain the visibility of road signs and signals. Cuttings of shrubs and branches from mature trees will be performed with suitable horticultural equipment and methods that do not further damage the trees. To prevent the possible export of invasive plants, cut vegetation should be chipped and evenly spread on site, provided the chips are spread outside the buffer zone, and raked to a depth not to exceed three inches, clear of all drainage ways. Alternatively, all cuttings and slash shall be removed from the site and properly disposed;

o. Installation, repair, replacement or removal of signs, signals, sign and signal posts and associated supports, braces, anchors, and foundations along existing paved roadways and their shoulders, provided that work is conducted as far from resource areas as practicable, and is located a minimum of ten feet from a resource area, any excess soil is removed from the project location, and any disturbed soils are stabilized as appropriate;

p. Pavement repair, resurfacing, and reclamation of existing roadways within the right-of-way configuration provided that the roadway and shoulders are not widened, no staging or stockpiling of materials, all disturbed road shoulders are stabilized within 72 hours of completion of the resurfacing or reclamation, and no work on the drainage system is performed, other than adjustments and/or repairs to respective structures within the roadway;



Maura Healey, Governor
Kimberley Driscoll, Lieutenant Governor
Monica Tibbitts-Nutt, Secretary & CEO
Jonathan L. Gulliver, Highway Administrator



ATTACHMENT C – Design Plans

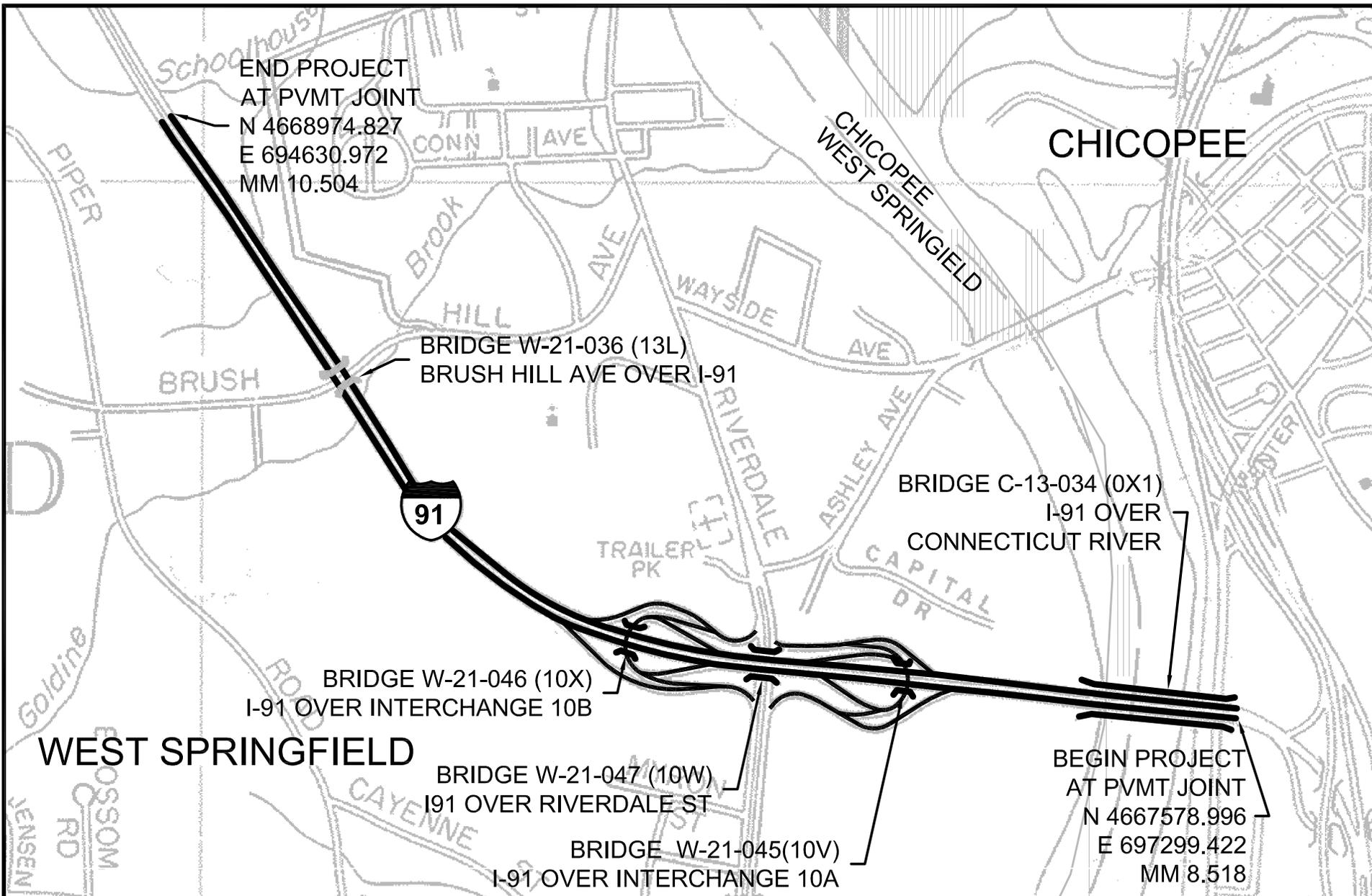

612097 LOCUS.DWG May-24



LOCUS

MM 8.518 TO 10.504
PROJECT LENGTH = 1.986 MILES

DATE:	12/27/2023
SCALE:	1" = 5'
PROJECT NO.:	612097
SHEET 1 OF 1	

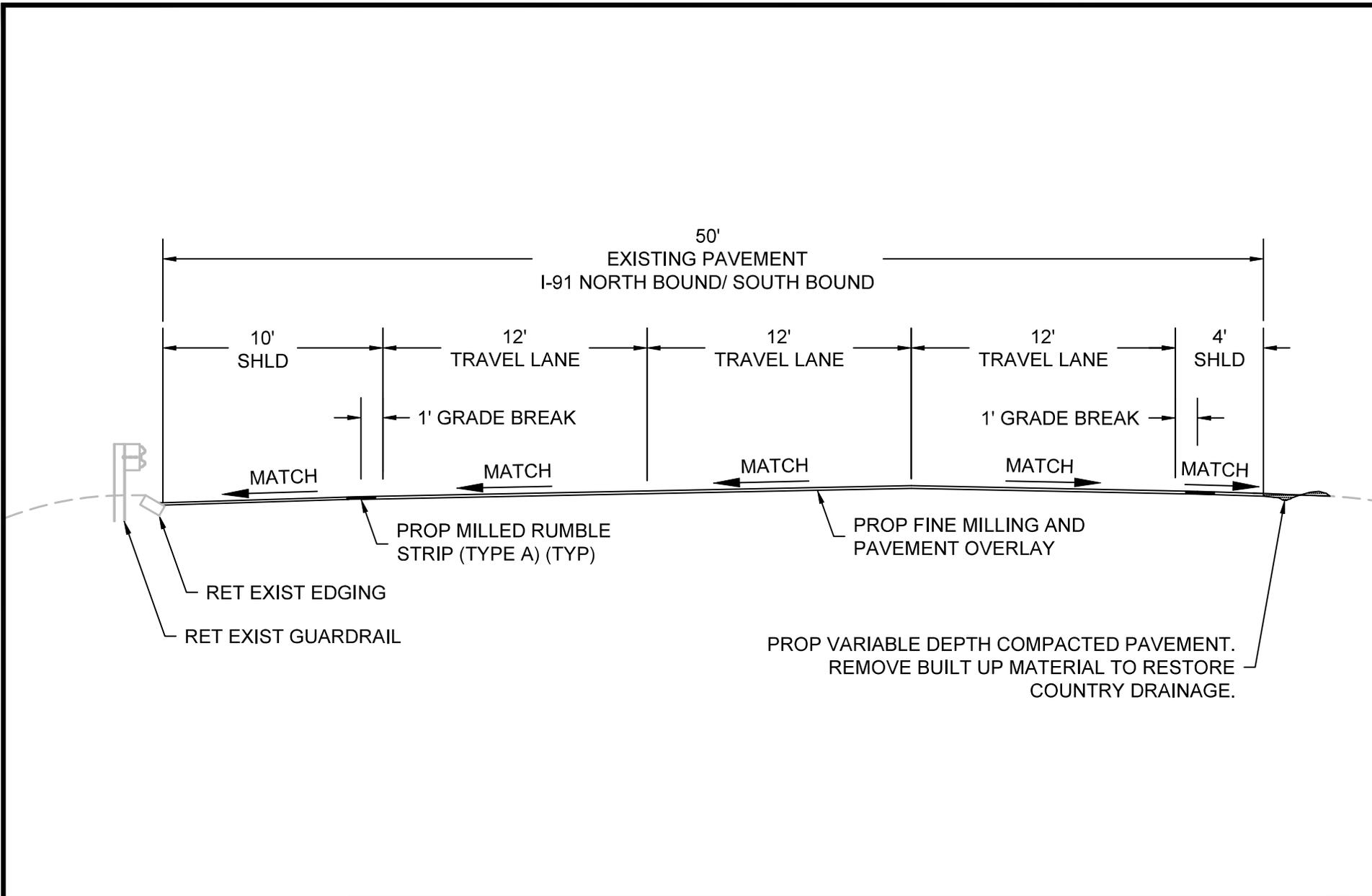

I-91 WEST SPRINGFIELD/CHICOPEE
TYPICAL SECTION - NORMAL CROWN (MM 8.518 TO 10.504)

DATE:	1/3/2023
SCALE:	NTS
PROJECT NO.:	612097
SHEET_1_OF_5	

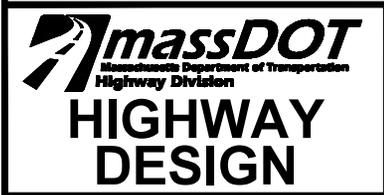
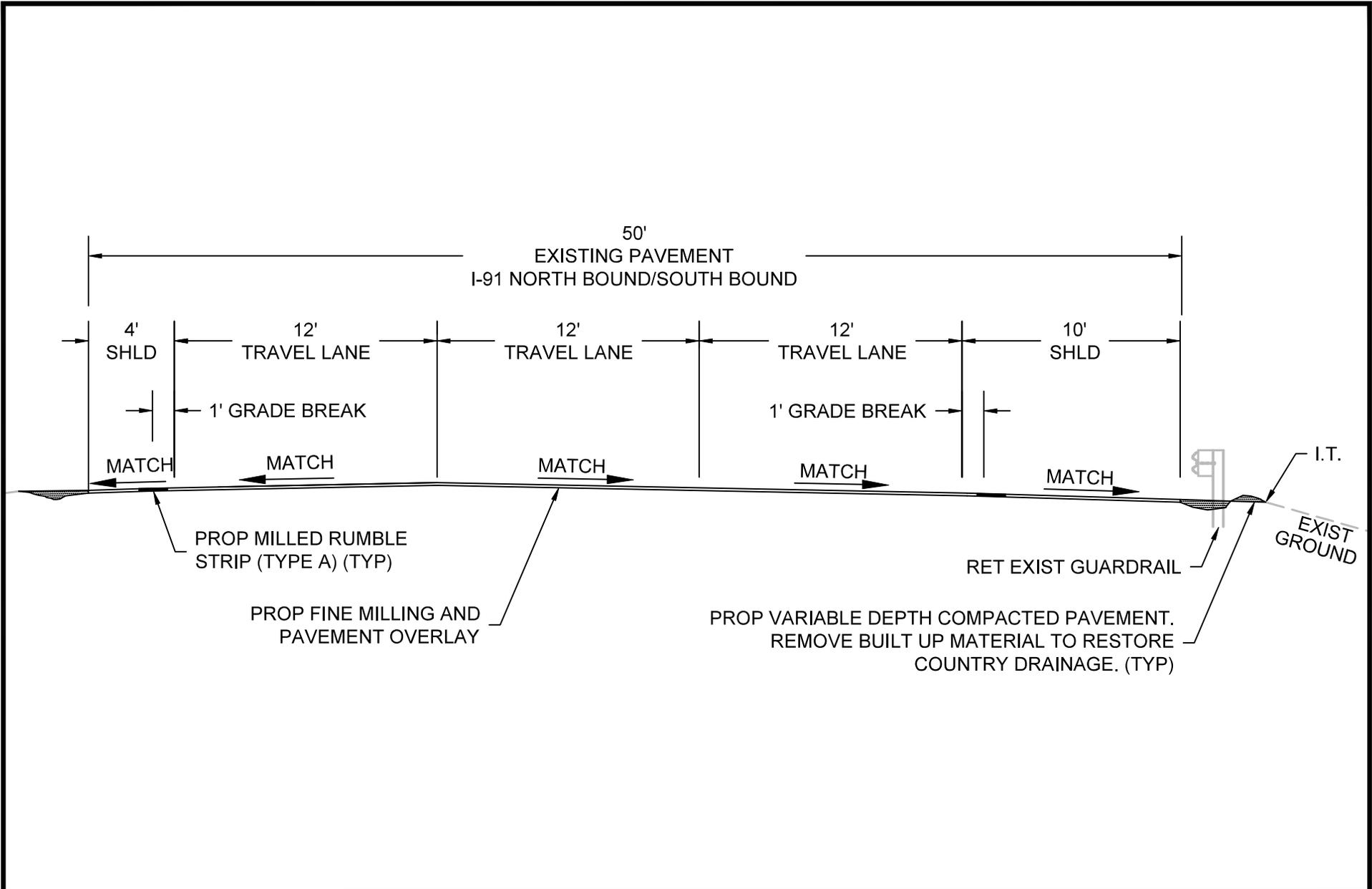

I-91 WEST SPRINGFIELD/CHICOPEE
TYPICAL SECTION - NORMAL CROWN (MM 8.518 TO 10.504)

DATE:	1/3/2023
SCALE:	NTS
PROJECT NO.:	612097
SHEET	2 OF 5

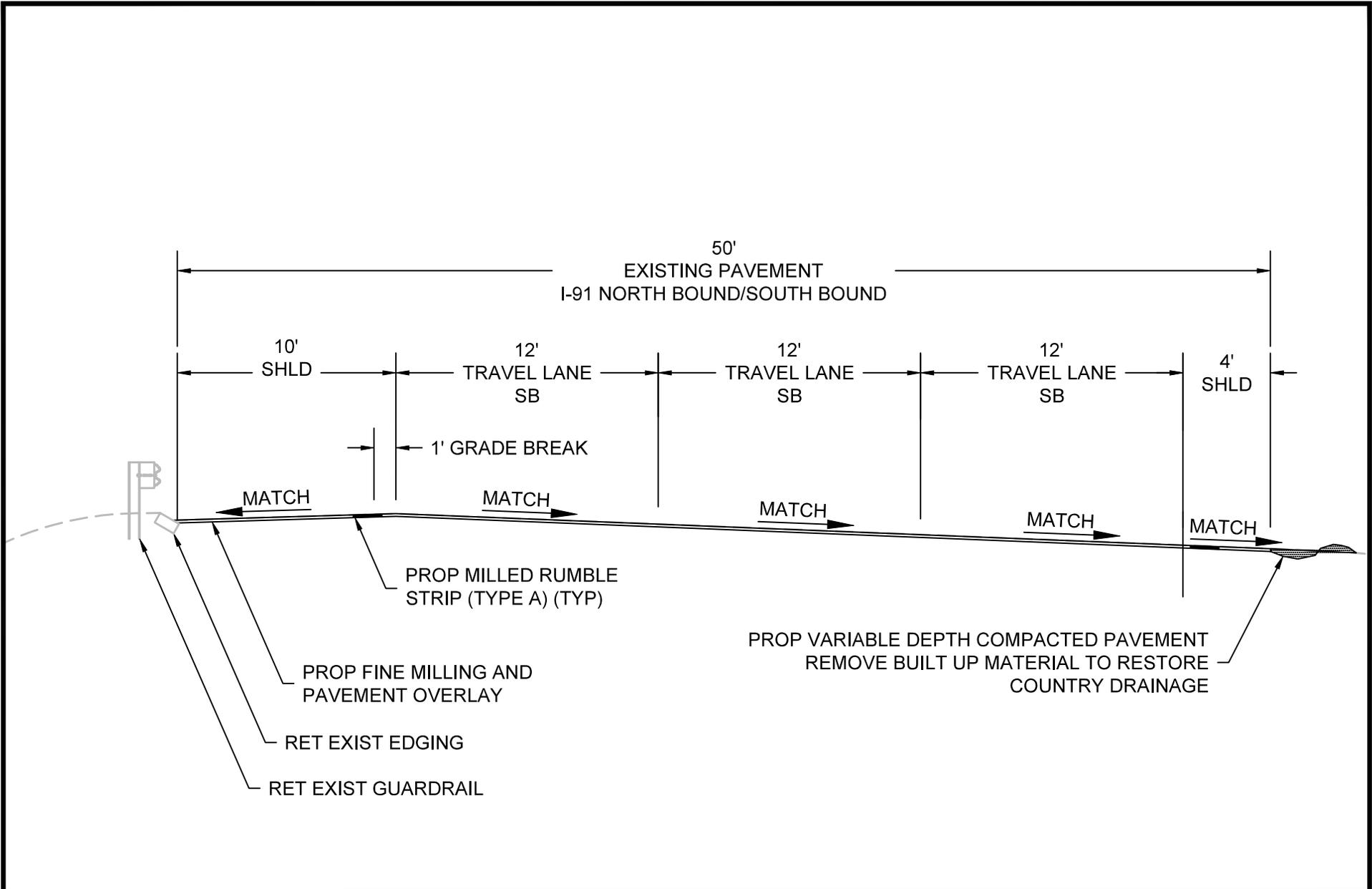

I-91 WEST SPRINGFIELD/CHICOPEE
 TYPICAL SECTION - SUPERELEVATED (MM 8.518 TO 10.504)

DATE:	1/3/2023
SCALE:	NTS
PROJECT NO.:	612097
SHEET	3_OF_5

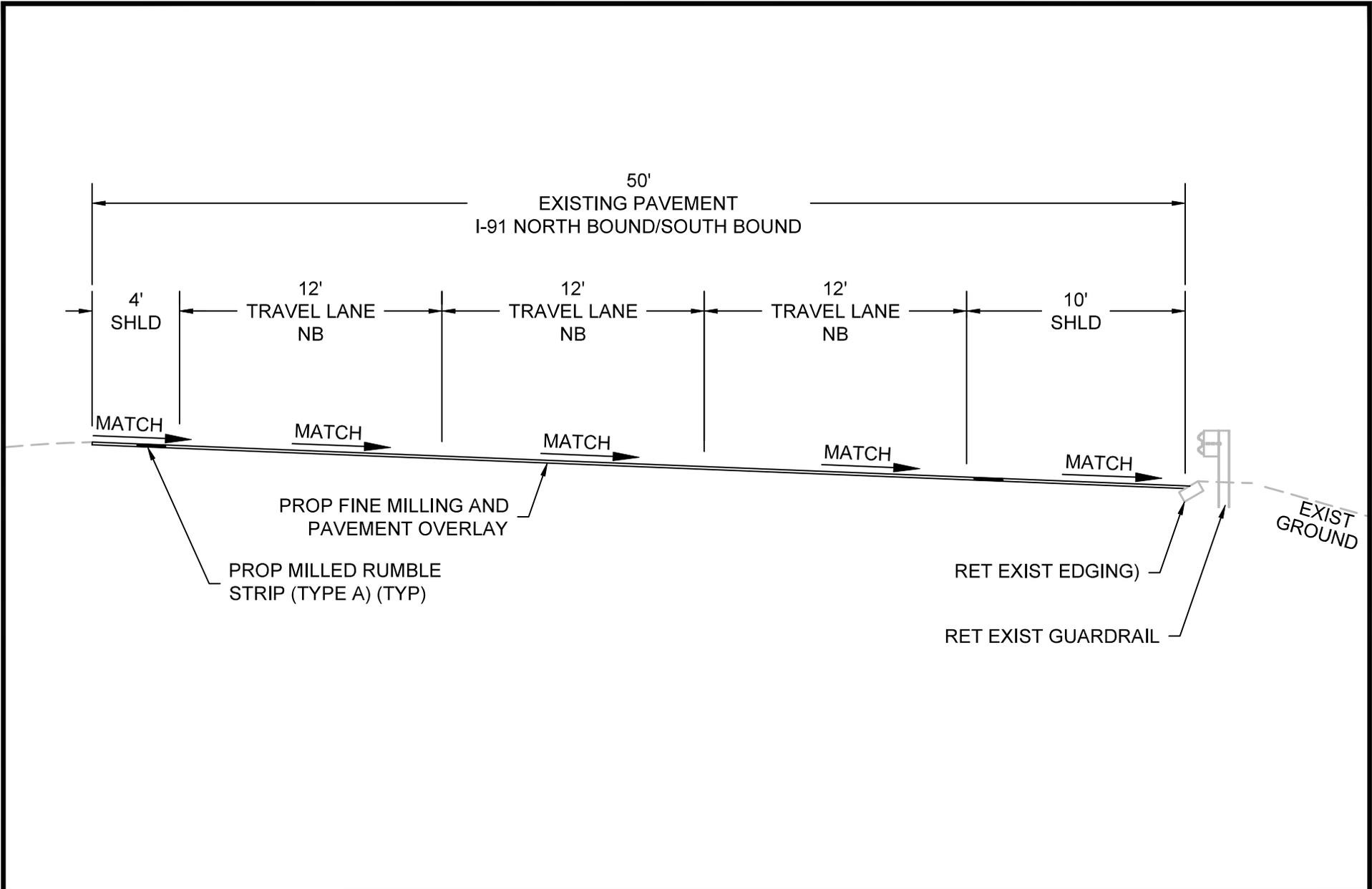

I-91 WEST SPRINGFIELD/CHICOPEE
TYPICAL SECTION - SUPERELEVATED (MM 8.518 TO 10.504)

DATE:	1/3/2023
SCALE:	NTS
PROJECT NO.:	612097
SHEET	4_OF_5

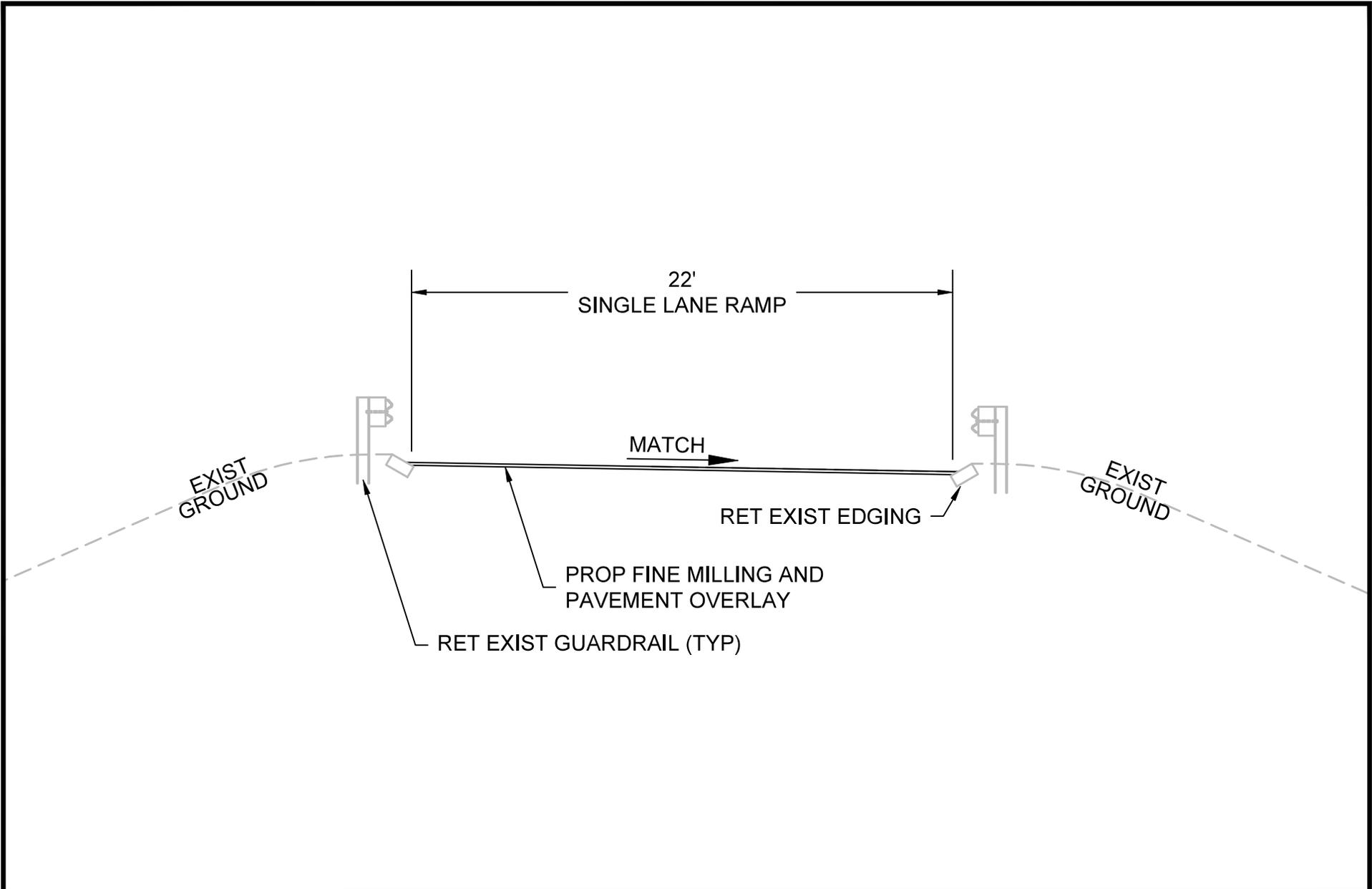

I-91 WEST SPRINGFIELD/CHICOPEE
TYPICAL SECTION (INTERCHANGE 10A AND 10B)

DATE:	1/3/2023
SCALE:	NTS
PROJECT NO.:	612097
SHEET	5_OF_5

LIMBS EXTENDING WITHIN THE LIMIT OF CLEARING AS DESIGNATED BY THE ENGINEER, SHALL BE TRIMMED FLUSH WITH TRUNK. SEE SPECIAL PROVISIONS FOR BASIS OF PAYMENT.

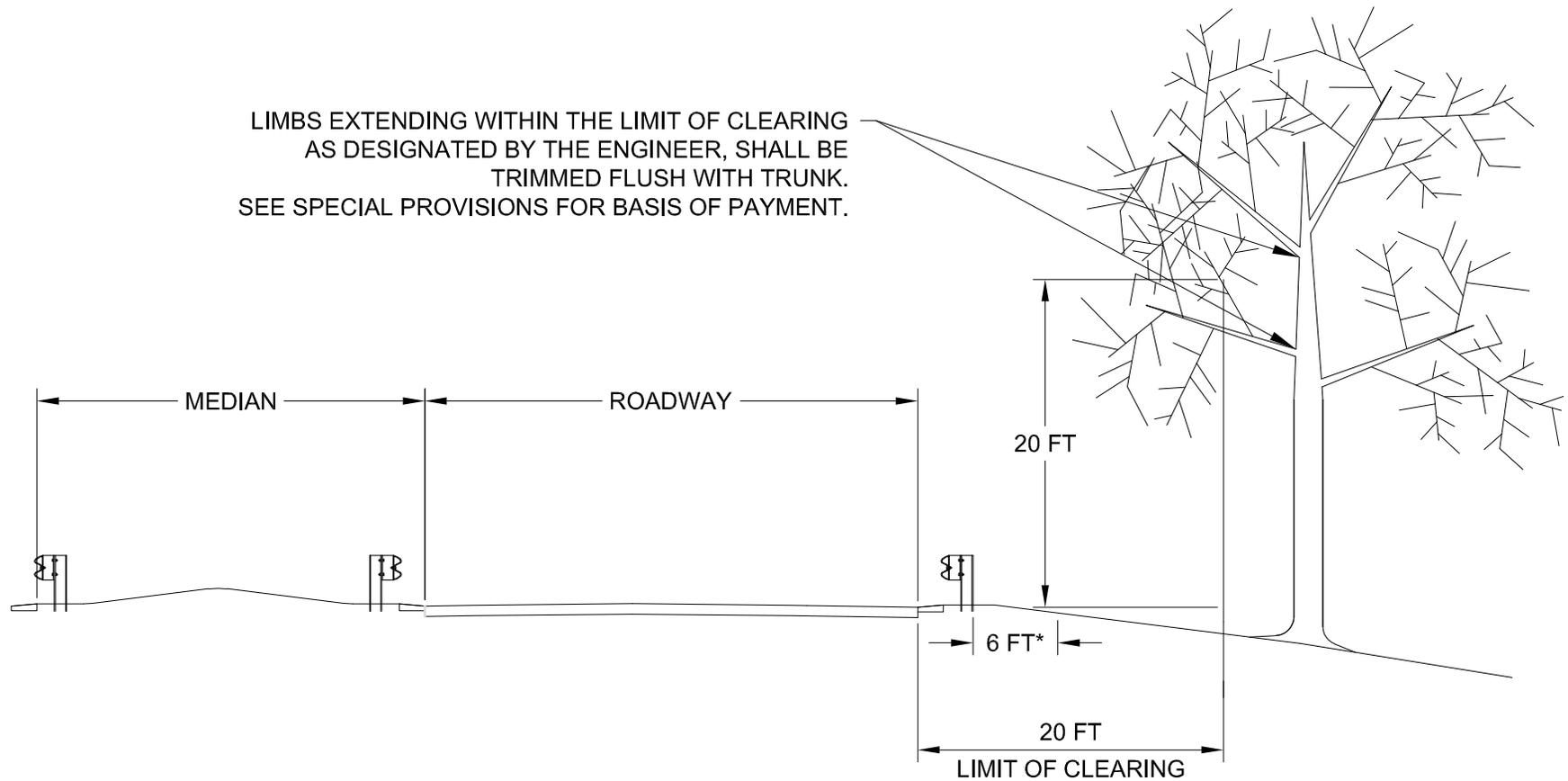

TYPICAL SECTION - ITEM 102.1
TREE TRIMMING
 NOT TO SCALE

NOTE: * WITHIN THE BUFFER ZONE OF BORDERING VEGETATED WETLANDS, TREE TRIMMING SHALL BE LIMITED TO 6 FEET BEYOND THE GUARD RAIL.



TREE TRIMMING

DATE: 12/28/23
SCALE: NTS
PROJECT NO.: 612097
SHEET 2 OF 32

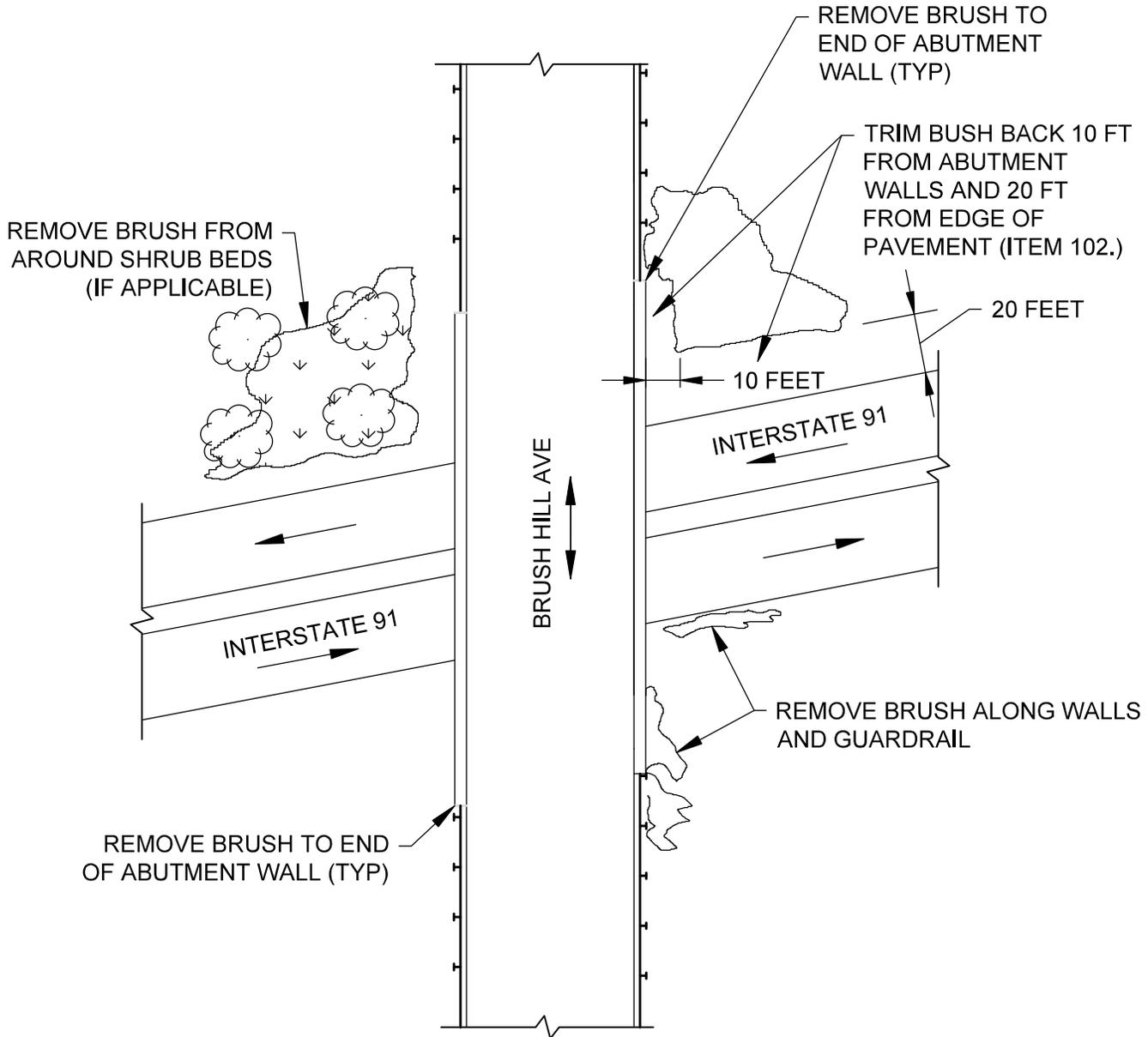

PLAN VIEW - ITEM 101.1:
CLEARING
(AT BRIDGES)
 NOT TO SCALE

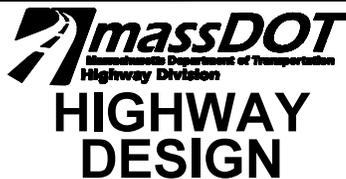

TREE CLEARING

DATE: 12/28/23
SCALE: NTS
PROJECT NO.: 612097
SHEET 4 OF 32

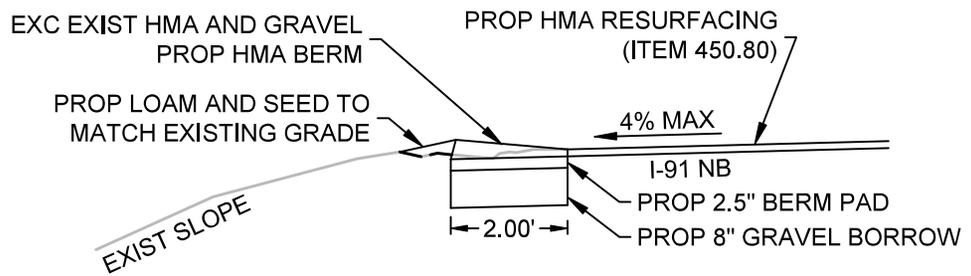
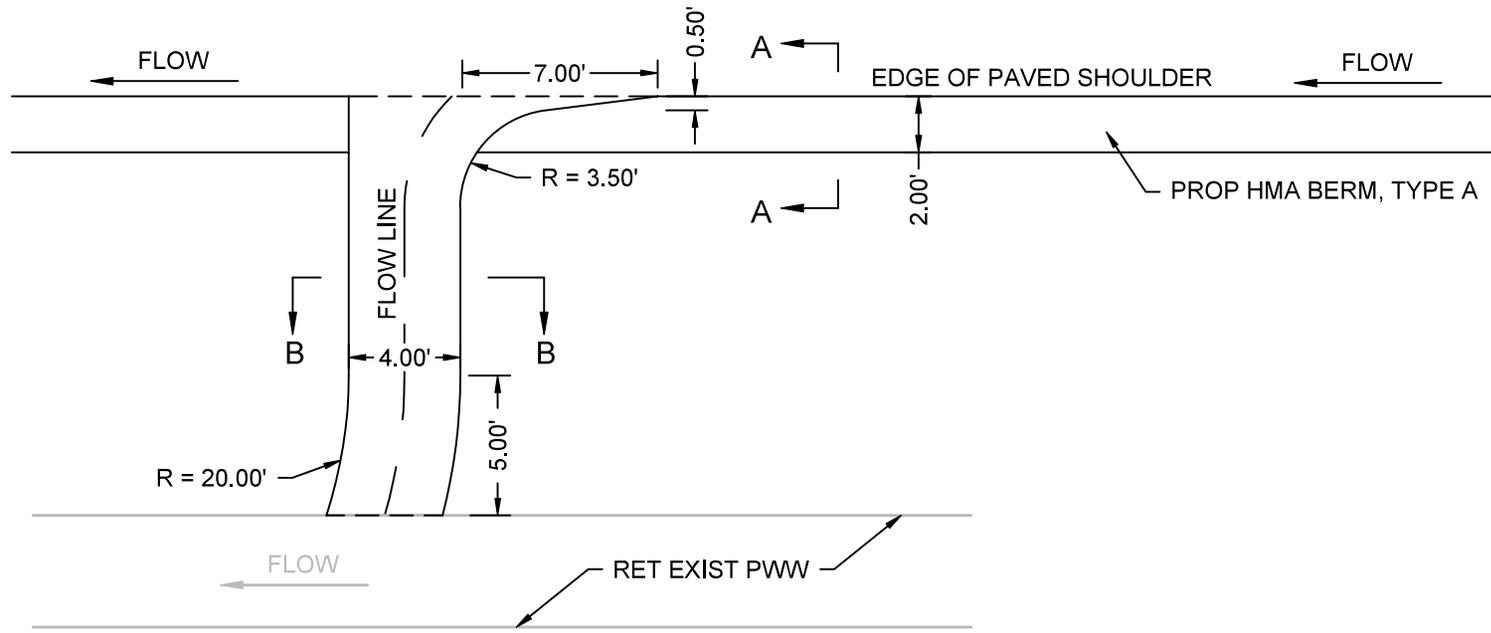

SECTION A-A

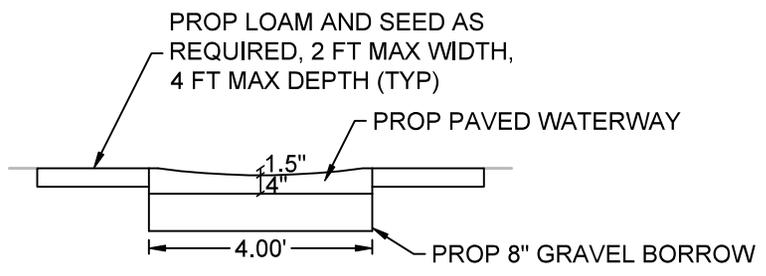

SECTION B-B



PROP PAVED WATERWAY I-91 NB SHOULDER (MM 9.68 TO 9.87)

DATE: 12/28/23
SCALE: NTS
PROJECT NO.: 612097
SHEET 8 OF 32



Maura Healey, Governor
Kimberley Driscoll, Lieutenant Governor
Monica Tibbitts-Nutt, Secretary & CEO
Jonathan L. Gulliver, Highway Administrator



ATTACHMENT D – Maps

Proposal No. 612097 - 129070
Wetland Resources Map

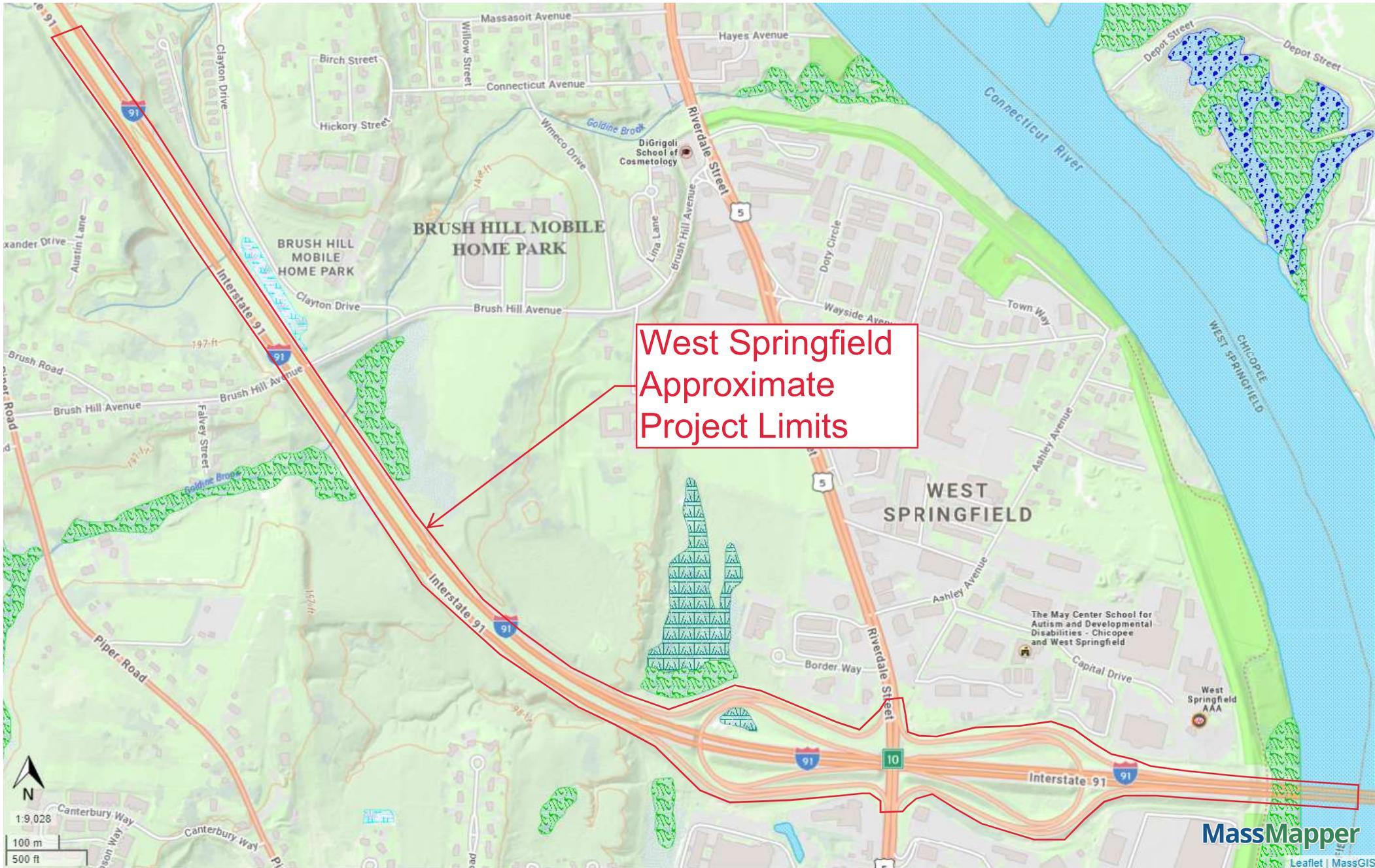

**West Springfield
 Approximate
 Project Limits**

DEP Wetlands Detailed With Outlines

- Barrier Beach System
- Barrier Beach-Deep Marsh
- Barrier Beach-Wooded Swamp Mixed Trees
- Barrier Beach-Coastal Beach
- Barrier Beach-Coastal Dune
- Barrier Beach-Marsh
- Barrier Beach-Salt Marsh
- Barrier Beach-Shrub Swamp
- Barrier Beach-Wooded Swamp Coniferous
- Barrier Beach-Wooded Swamp Deciduous
- Bog
- Coastal Bank Bluff or Sea Cliff
- Coastal Beach
- Coastal Dune
- Cranberry Bog
- Deep Marsh
- Barrier Beach-Open Water
- Open Water
- Rocky Intertidal Shore
- Salt Marsh
- Shallow Marsh Meadow or Fen
- Shrub Swamp
- Tidal Flat
- Wooded Swamp Coniferous
- Wooded Swamp Deciduous
- Wooded Swamp Mixed Trees

Bordering Land Subject to Flooding

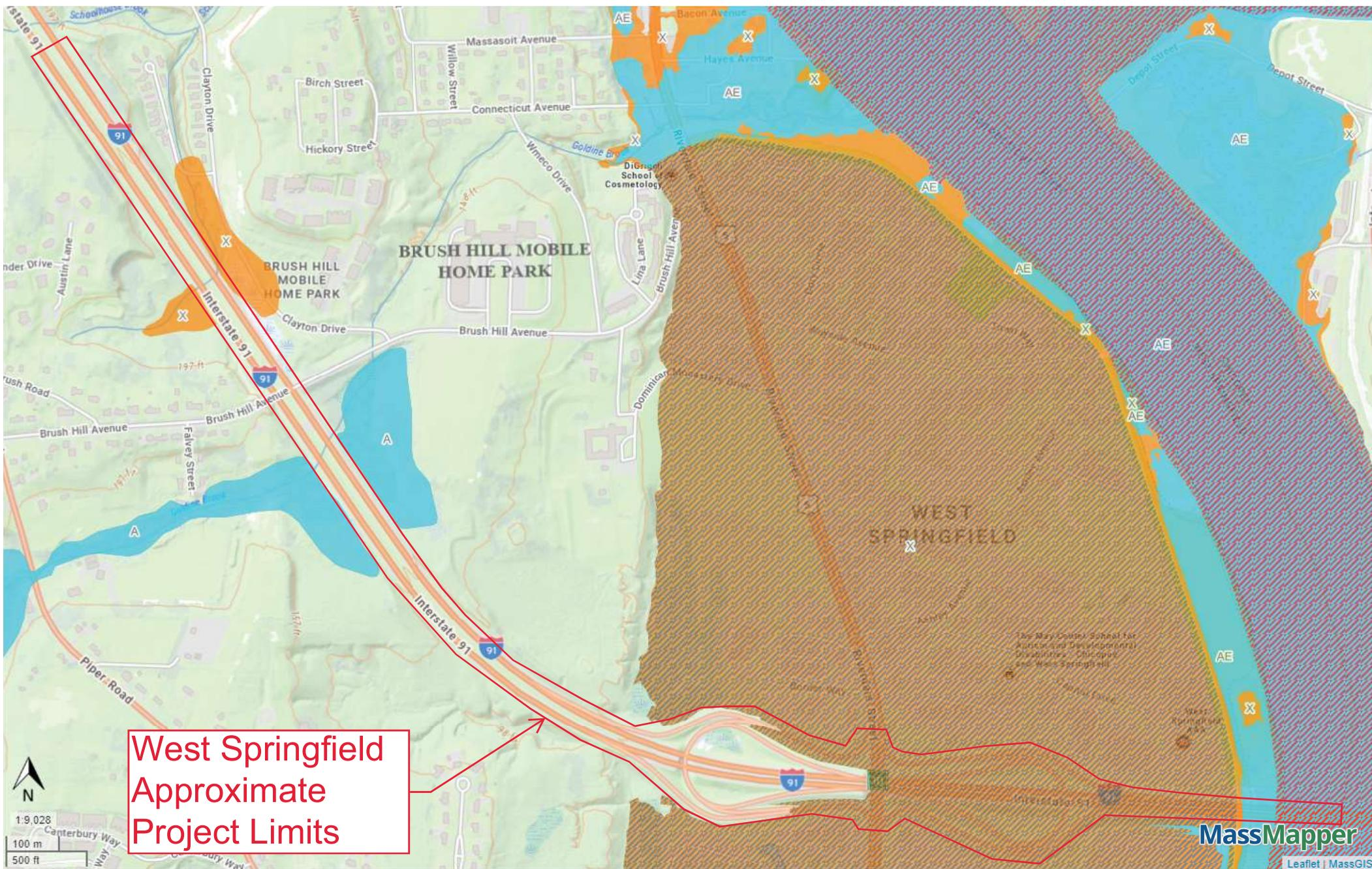

FEMA National Flood Hazard Layer Polygons

- 1% Annual Chance Flood Hazard
- Regulatory Floodway
- Area of Undetermined Flood Hazard
- 0.2% Annual Chance Flood Hazard
- Area with Reduced Risk Due to Levee
- Area Not Included

West Springfield
Approximate
Project Limits

Signature: *Paula H. Simmons*

Email: paula.simmons@dot.state.ma.us

Proposal No. 612097 - 129070

THIS PAGE IS INTENTIONALLY LEFT BLANK



Maura Healey, Governor
Kimberley Driscoll, Lieutenant Governor
Monica Tibbitts-Nutt, Secretary & CEO
Jonathan L. Gulliver, Highway Administrator



Return Receipt Requested

August 5, 2024

Chicopee Conservation Commission
Chicopee City Hall
17 Springfield Street
Chicopee, MA 01013

Re: Request for Determination of
Applicability
612097 West Springfield/Chicopee -
Interstate Maintenance and Related
Work on I-91

Dear Commission Members:

Please find enclosed a Request for Determination of Applicability for *West Springfield/Chicopee – Interstate Maintenance and Related Work on I-91* in the City of Chicopee. This project is being filed under the Massachusetts Wetlands Protection Act, M.G.L. Chapter 131 § 40, and its regulations, 310 CMR 10.00. No findings under City Bylaws, including any Wetland Bylaws, are requested.

The MassDOT Highway Division is an agency of State Government and as such is exempt from local Conservation Commission by-laws and fees. For MassDOT to provide advertising payment, the newspaper must directly bill the Massachusetts Department of Transportation, at the address shown below.

As indicated under 310 CMR: 10:05(3)(b)1, a Determination of Applicability shall be issued within 21 days after the date of receipt of an RDA. If within the 21 days you have questions or would like to schedule a site visit, please contact Billie Li, District Environmental Engineer, at (857)-286-3311.

Sincerely,

Patricia A. Leavenworth, P.E.
District Highway Director

BL *BL*

BL/
C- PKS (w/encl.) *PKS*
DEP-WERO (w/encl.)
Encl.

811 North King Street, Northampton, MA 01060
Tel: (857) 368-2000, Fax: (857) 368-0200
mass.gov/massdot



Massachusetts Department of Environmental Protection
 Bureau of Water Resources - Wetlands

WPA Form 1- Request for Determination of Applicability Chicopee

Massachusetts Wetlands Protection Act M.G.L. c. 131, §40

Municipality

A. General Information

Important:

When filling out forms on the computer, use only the tab key to move your cursor - do not use the return key.



1. Applicant:

<u>Patricia</u> First Name	<u>Leavenworth</u> Last Name
<u>811 N King Street</u> Address	
<u>Northampton</u> City/Town	<u>MA</u> State
	<u>01060</u> Zip Code
<u></u> Phone Number	<u></u> Email Address

2. Property Owner (if different from Applicant):

<u></u> First Name	<u></u> Last Name
<u></u> Address	
<u></u> City/Town	<u></u> State
	<u></u> Zip Code
<u></u> Phone Number	<u></u> Email Address (if known)

3. Representative (if any)

<u>Billie</u> First Name	<u>Li</u> Last Name
<u>MassDOT</u> Company Name	
<u>811 N. King Street</u> Address	
<u>Northampton</u> City/Town	<u>MA</u> State
	<u>01060</u> Zip Code
<u>857-286-3311</u> Phone Number	<u>Billie.m.li@dot.state.ma.us</u> Email Address (if known)

B. Project Description

1. a. Project Location (use maps and plans to identify the location of the area subject to this request):

<u>I-91</u> Street Address	<u>Chicopee</u> City/Town
<u>42.13571</u> Latitude (Decimal Degrees Format with 5 digits after decimal e.g. XX.XXXXX)	<u>-72.61524</u> Longitude (Decimal Degrees Format with 5 digits after decimal e.g. -XX.XXXXX)
<u></u> Assessors' Map Number	<u></u> Assessors' Lot/Parcel Number

b. Area Description (use additional paper, if necessary):
See Attachment A

c. Plan and/or Map Reference(s): (use additional paper if necessary)

<u>See Design Plans - Attachment C</u> Title	<u>As Noted</u> Date
<u>See Maps - Attachment D</u> Title	<u>7/17/2024</u> Date

[How to find Latitude and Longitude](#)

[and how to convert to decimal degrees](#)



Massachusetts Department of Environmental Protection
Bureau of Water Resources - Wetlands

WPA Form 1- Request for Determination of Applicability Chicopee

Massachusetts Wetlands Protection Act M.G.L. c. 131, §40

Municipality

B. Project Description (cont.)

2. a. Activity/Work Description (use additional paper and/or provide plan(s) of Activity, if necessary):

See Attachment A

- b. Identify provisions of the Wetlands Protection Act or regulations which may exempt the applicant from having to file a Notice of Intent for all or part of the described work (use additional paper, if necessary).

See Attachment B

3. a. If this application is a Request for Determination of Scope of Alternatives for work in the Riverfront Area, indicate the one classification below that best describes the project.

- Single family house on a lot recorded on or before 8/1/96
- Single family house on a lot recorded after 8/1/96
- Expansion of an existing structure on a lot recorded after 8/1/96
- Project, other than a single-family house or public project, where the applicant owned the lot before 8/7/96
- New agriculture or aquaculture project
- Public project where funds were appropriated prior to 8/7/96
- Project on a lot shown on an approved, definitive subdivision plan where there is a recorded deed restriction limiting total alteration of the Riverfront Area for the entire subdivision
- Residential subdivision; institutional, industrial, or commercial project
- Municipal project
- District, county, state, or federal government project
- Project required to evaluate off-site alternatives in more than one municipality in an Environmental Impact Report under MEPA or in an alternatives analysis pursuant to an application for a 404 permit from the U.S. Army Corps of Engineers or 401 Water Quality Certification from the Department of Environmental Protection.

- b. Provide evidence (e.g., record of date subdivision lot was recorded) supporting the classification above (use additional paper and/or attach appropriate documents, if necessary.)
-

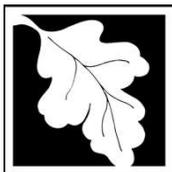

Massachusetts Department of Environmental Protection
Bureau of Water Resources - Wetlands

WPA Form 1- Request for Determination of Applicability Chicopee
Massachusetts Wetlands Protection Act M.G.L. c. 131, §40 Municipality

C. Determinations

1. I request the Chicopee make the following determination(s). Check any that apply:
Conservation Commission

- a. whether the **area** depicted on plan(s) and/or map(s) referenced above is an area subject to jurisdiction of the Wetlands Protection Act.
- b. whether the **boundaries** of resource area(s) depicted on plan(s) and/or map(s) referenced above are accurately delineated.
- c. whether the **Activities** depicted on plan(s) referenced above is subject to the Wetlands Protection Act and its regulations.
- d. whether the area and/or Activities depicted on plan(s) referenced above is subject to the jurisdiction of any **municipal wetlands' ordinance** or **bylaw** of:

Name of Municipality

- e. whether the following **scope of alternatives** is adequate for Activities in the Riverfront Area as depicted on referenced plan(s).
- _____

D. Signatures and Submittal Requirements

I hereby certify under the penalties of perjury that the foregoing Request for Determination of Applicability and accompanying plans, documents, and supporting data are true and complete to the best of my knowledge.

I further certify that the property owner, if different from the applicant, and the appropriate DEP Regional Office were sent a complete copy of this Request (including all appropriate documentation) simultaneously with the submittal of this Request to the Conservation Commission.

Failure by the applicant to send copies in a timely manner may result in dismissal of the Request for Determination of Applicability.

Signatures:

I also understand that notification of this Request will be placed in a local newspaper at my expense in accordance with Section 10.05(3)(b)(1) of the Wetlands Protection Act regulations.

Patricia A. Leavenworth

Signature of Applicant

08/05/2024

Date

Billie Li

Signature of Representative (if any)

08/05/2024

Date



Maura Healey, Governor
Kimberley Driscoll, Lieutenant Governor
Monica Tibbitts-Nutt, Secretary & CEO
Jonathan L. Gulliver, Highway Administrator



Table of Attachments

Attachment A – Project Description

Attachment B – Wetlands Protection Act Provisions for Exemption

Attachment C – Design Information

Attachment D – Maps



Maura Healey, Governor
 Kimberley Driscoll, Lieutenant Governor
 Monica Tibbitts-Nutt, Secretary & CEO
 Jonathan L. Gulliver, Highway Administrator



Attachment A – Project Description

Area Description

The project is located on I-91, from approximately Mile Marker 8.5 to 10.5 and includes the Connecticut River Bridge. The project limits within the City of Chicopee are from Mile Marker 8.5 to the city limit on the Connecticut River Bridge (approximately 800 ft). All proposed work is within the existing State Highway Layout. The area of work includes the 200-Foot Riverfront Area, and Bordering Land Subject to Flooding (FEMA Zone X & AE).

Activity & Description of Work

The portion of work within the City of Chicopee is limited to approximately 800 ft. The project scope of work includes roadway & bridge deck resurfacing, bridge deck repairs, clearing roadway side slopes, adjusting and/or rebuilding drainage structures, selective tree trimming, and the use of erosion and sedimentation control measures. Items that may be included as needed include guardrail repairs, traffic striping and other incidental items required to complete the work. For the portion of the project located within Bordering Lands Subject to Flooding, there will be no reduction in flood storage capacity as no changes in elevation are proposed. No widening of the existing roadway or its shoulders is proposed. All work will be conducted to avoid impacts to resource areas.

Within the 200-Foot Riverfront Area, the activities include roadway & bridge deck resurfacing, bridge deck repairs, selective tree trimming, adjusting and/or rebuilding drainage structures. Erosion and sedimentation control measures will be installed prior to any work and removed upon the completion of work. The work in this area will remain within the existing pavement limits. Within the area that appears to be mapped as Bordering Land Subject to Flooding, work will occur on the existing elevated roadway surface and will not have impacts to flood storage capacity of the BLSF. Because of the significant elevation difference, it is anticipated that the work will not adversely affect the resource areas below.



Maura Healey, Governor
 Kimberley Driscoll, Lieutenant Governor
 Monica Tibbitts-Nutt, Secretary & CEO
 Jonathan L. Gulliver, Highway Administrator



Attachment B – Wetlands Protection Act Provisions for Exemption

310 CMR 10.02(2)(a) Activities Within the Areas Subject to Protection under M.G.L. c. 131, § 40.

Any activity proposed or undertaken within an area specified in 310 CMR 10.02(1), which will remove, fill, dredge or alter that area, is subject to Regulation under M.G.L. c. 131, § 40 and requires the filing of a Notice of Intent except:

1. Minor activities within the riverfront area meeting the requirement of 310 CMR 10.02(2)(b)1. And 2.; and
2. Activities conducted to maintain, repair or replace, but not substantially change or enlarge an existing lawfully located structure or facility used in the service of the public and used to provide electric, gas, water, sewer, telephone, telegraph and other communication services, provided said work utilizes the best practical measures to avoid or minimize impacts to wetland resource areas outside the footprint of said structure or facility. A project proponent claiming that work to remove, fill, dredge or alter an area specified in 310 CMR 10.02(2) does not require the filing of a Notice of Intent has the burden of establishing that the work is not subject to Regulation under M.G.L. c. 131, § 40.

310 CMR 10.02(2)(b) Activities Within the Buffer Zone.

Any activity other than minor activities identified in 310 CMR 10.02(2)(b)2. proposed or undertaken within 100 feet of an area specified in 310 CMR 10.02(1)(a) (hereinafter called the Buffer Zone) which, in the judgment of the issuing authority, will alter an Area Subject to Protection under M.G.L. c. 131, § 40 is subject to regulation under M.G.L. c. 131, § 40 and requires the filing of a Notice of Intent. (See also 310 CMR 10.05(3)(a)2.). The areas subject to jurisdiction identified in 310 CMR 10.02(1)(b) through (f) do not have a buffer zone.

1. Minor activities, as described in 310 CMR 10.02(2)(b)2., within the buffer zone and outside any areas specified in 310 CMR 10.02(1)(a) through (e) are not otherwise subject to regulation under M.G.L. c. 131, § 40 provided that the work is performed: solely within the buffer zone, as prescribed in 310 CMR 10.02(2)(b)2.a. through q., in a manner so as to reduce the potential for any adverse impacts to the resource area during construction, and with post-construction measures implemented to stabilize any disturbed areas. Factors to consider when measuring the potential for adverse impacts to resource areas include the extent of the work, the proximity to the resource area, the need for erosion controls, and the measures employed to prevent adverse impacts to resource areas during and following the work.
2. The following minor activities, provided that they comply with 310 CMR 10.02(2)(b)1., are not otherwise subject to regulation under M.G.L. c. 131, § 40:

811 North King Street, Northampton, MA 01060
 Tel: (857) 368-2000, Fax: (857) 368-0200
mass.gov/massdot



Maura Healey, Governor
 Kimberley Driscoll, Lieutenant Governor
 Monica Tibbitts-Nutt, Secretary & CEO
 Jonathan L. Gulliver, Highway Administrator



...

c. Vista pruning, provided the activity is located more than 50 feet from the mean annual high water line within a Riverfront Area or from Bordering Vegetated Wetland, whichever is farther. (Pruning of landscaped areas is not subject to jurisdiction under 310 CMR 10.00);

...

n. Vegetation cutting for road safety maintenance, limited to the following:

i. Removal of diseased or damaged trees or branches that pose an immediate and substantial threat to driver safety from falling into the roadway;

ii. Removal of shrubbery or branches to maintain clear guardrails; such removal shall extend no further than six feet from the rear of the guardrail;

iii. Removal of shrubbery or branches to maintain sight distances at existing intersections; such removal shall be no farther than five feet beyond the "sight triangles" established according to practices set forth in American Association of State Highway and Transportation Officials (AASHTO) A Policy on Geometric Design of Highways and Streets, 2011, 6th edition, and such removal is a minimum of ten feet from a resource area, other than Riverfront Area; and

iv. Removal of shrubbery, branches, or other vegetation required to maintain the visibility of road signs and signals. Cuttings of shrubs and branches from mature trees will be performed with suitable horticultural equipment and methods that do not further damage the trees. To prevent the possible export of invasive plants, cut vegetation should be chipped and evenly spread on site, provided the chips are spread outside the buffer zone, and raked to a depth not to exceed three inches, clear of all drainage ways. Alternatively, all cuttings and slash shall be removed from the site and properly disposed;

o. Installation, repair, replacement or removal of signs, signals, sign and signal posts and associated supports, braces, anchors, and foundations along existing paved roadways and their shoulders, provided that work is conducted as far from resource areas as practicable, and is located a minimum of ten feet from a resource area, any excess soil is removed from the project location, and any disturbed soils are stabilized as appropriate;

p. Pavement repair, resurfacing, and reclamation of existing roadways within the right-of-way configuration provided that the roadway and shoulders are not widened, no staging or stockpiling of materials, all disturbed road shoulders are stabilized within 72 hours of completion of the resurfacing or reclamation, and no work on the drainage system is performed, other than adjustments and/or repairs to respective structures within the roadway;



Maura Healey, Governor
Kimberley Driscoll, Lieutenant Governor
Monica Tibbitts-Nutt, Secretary & CEO
Jonathan L. Gulliver, Highway Administrator



ATTACHMENT C – Design Plans

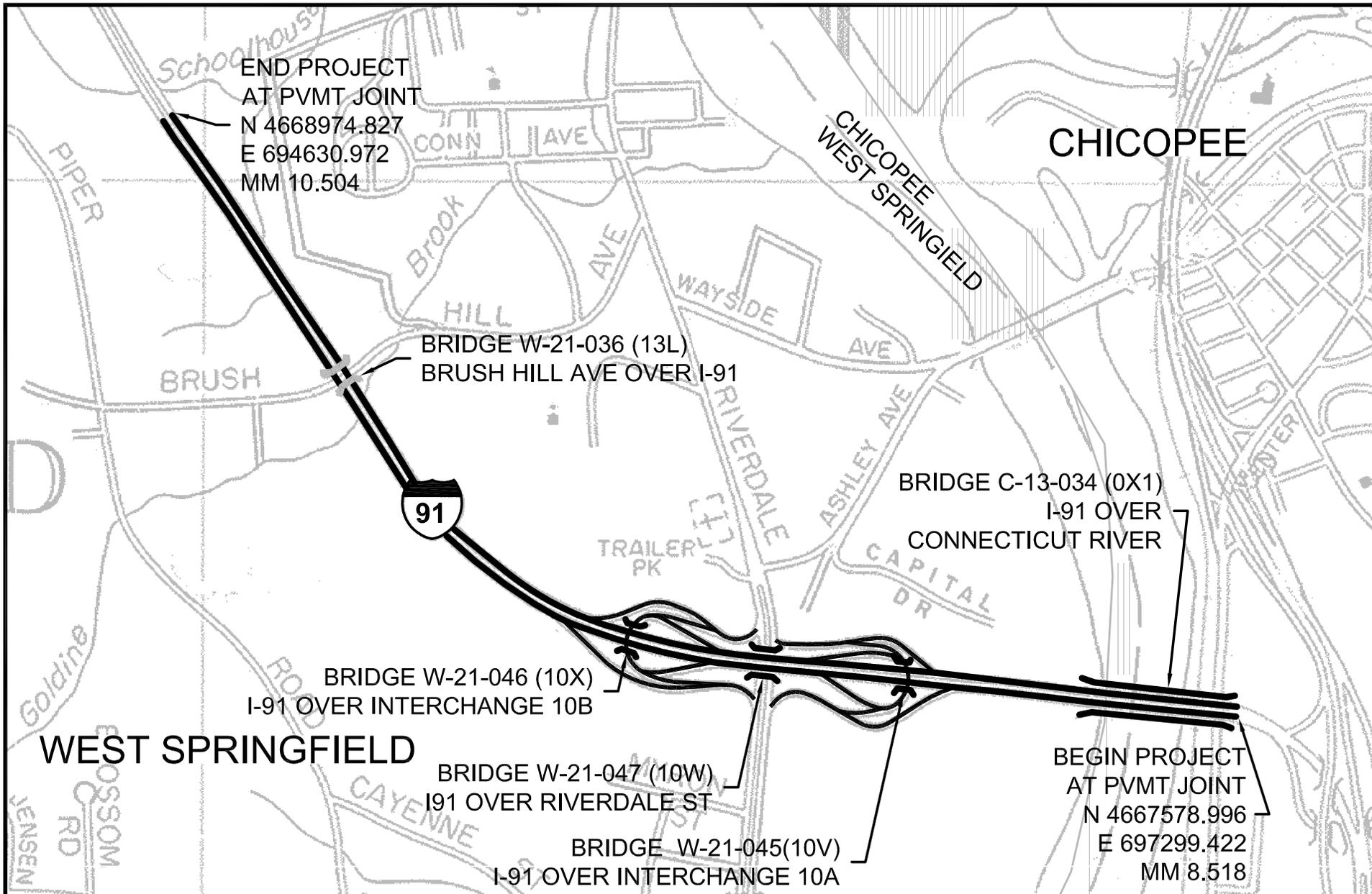

612097 LOCUS.DWG May-24

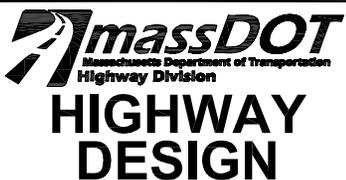

LOCUS

MM 8.518 TO 10.504
PROJECT LENGTH = 1.986 MILES

DATE:	12/27/2023
SCALE:	1" = 5'
PROJECT NO.:	612097
SHEET	1 OF 1

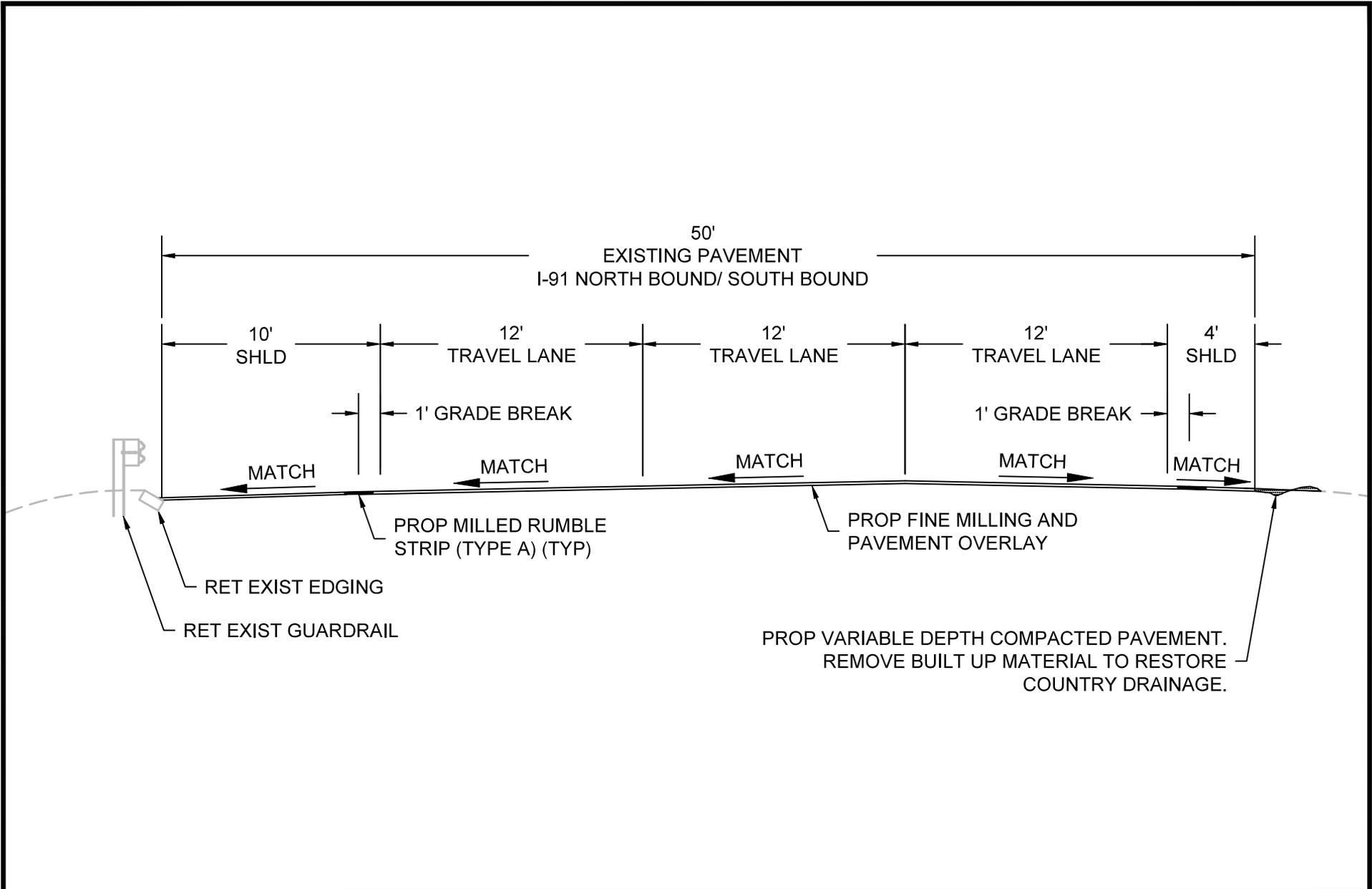

I-91 WEST SPRINGFIELD/CHICOPEE
TYPICAL SECTION - NORMAL CROWN (MM 8.518 TO 10.504)

DATE:	1/3/2023
SCALE:	NTS
PROJECT NO.:	612097
SHEET_1_OF_5	

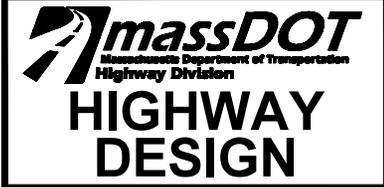
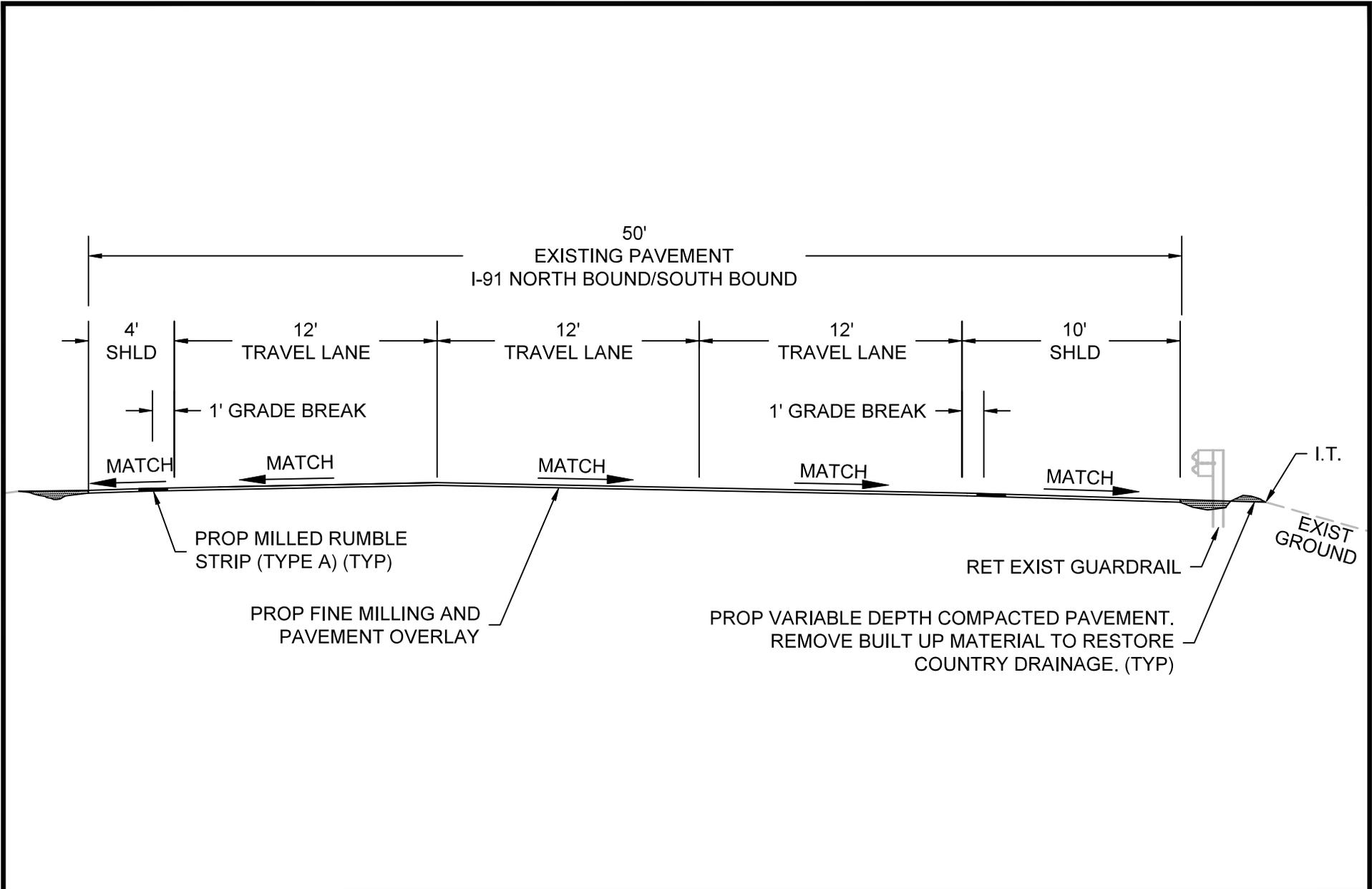

I-91 WEST SPRINGFIELD/CHICOPEE
TYPICAL SECTION - NORMAL CROWN (MM 8.518 TO 10.504)

DATE:	1/3/2023
SCALE:	NTS
PROJECT NO.:	612097
SHEET	2 OF 5

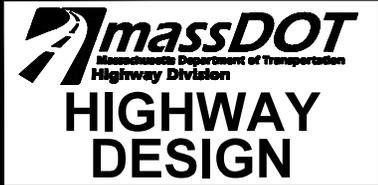
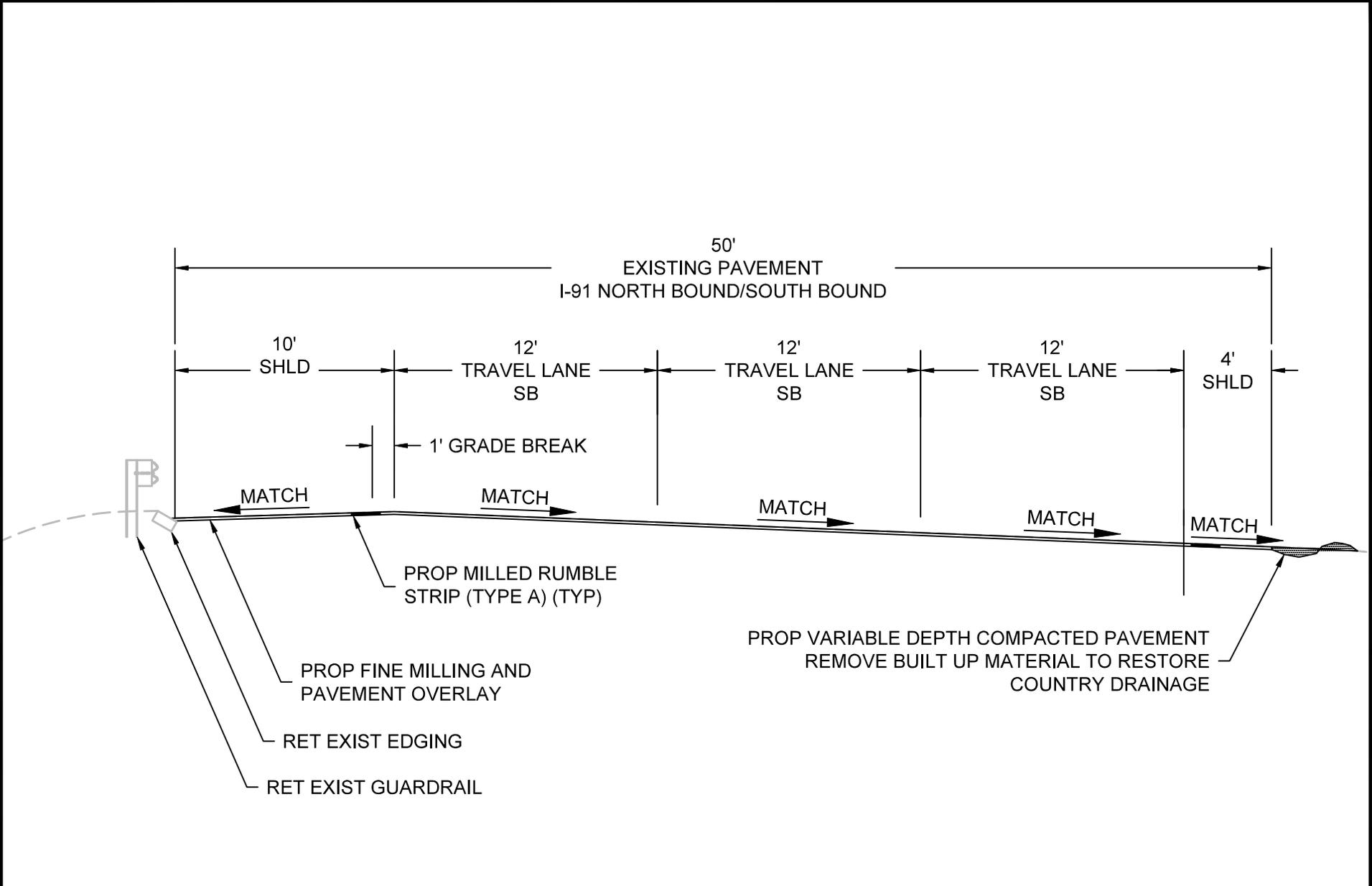

I-91 WEST SPRINGFIELD/CHICOPEE
TYPICAL SECTION - SUPERELEVATED (MM 8.518 TO 10.504)

DATE:	1/3/2023
SCALE:	NTS
PROJECT NO.:	612097
SHEET	3_OF_5

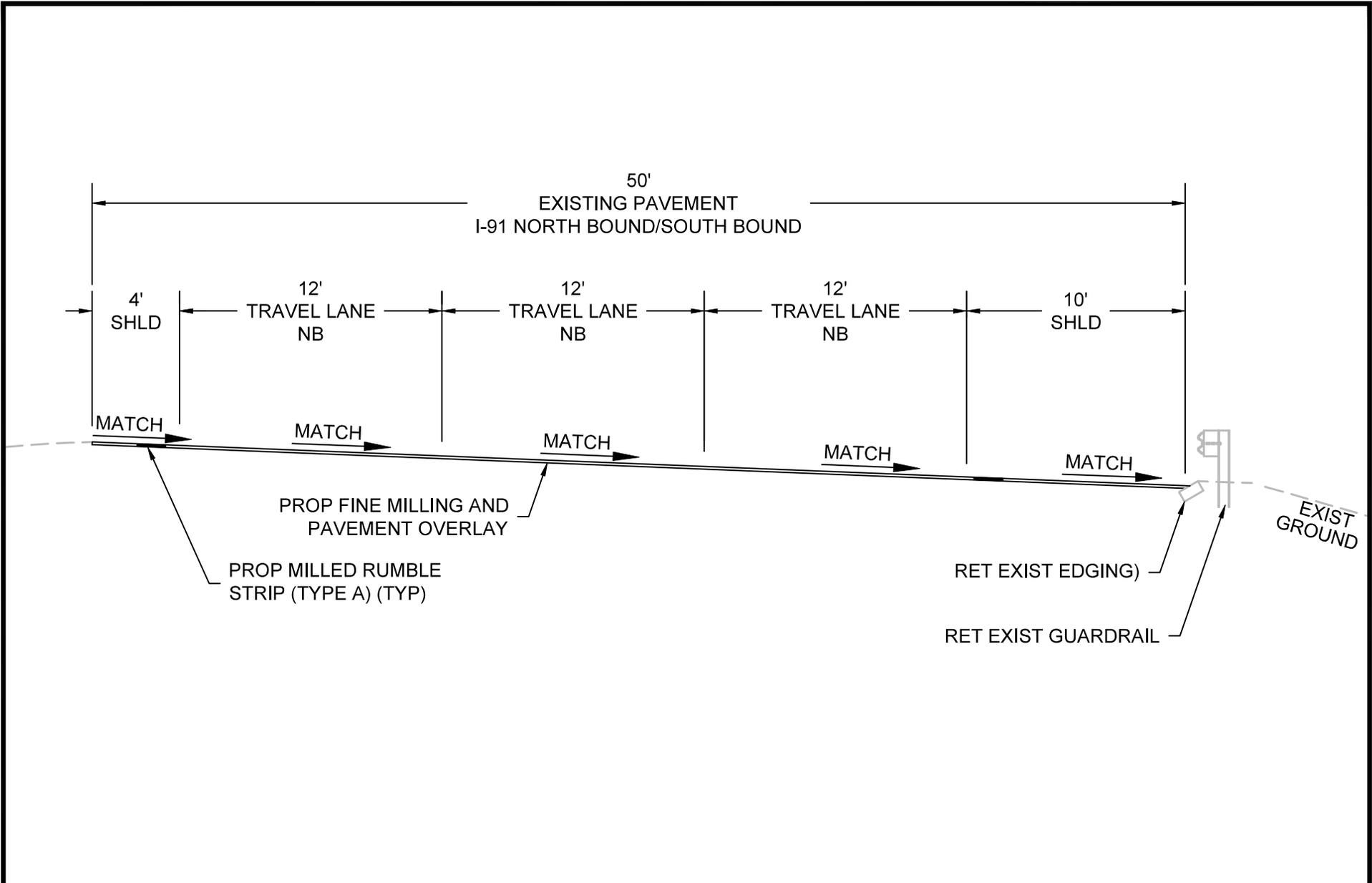

I-91 WEST SPRINGFIELD/CHICOPEE
 TYPICAL SECTION - SUPERELEVATED (MM 8.518 TO 10.504)

DATE:	1/3/2023
SCALE:	NTS
PROJECT NO.:	612097
SHEET	4 OF 5

LIMBS EXTENDING WITHIN THE LIMIT OF CLEARING AS DESIGNATED BY THE ENGINEER, SHALL BE TRIMMED FLUSH WITH TRUNK. SEE SPECIAL PROVISIONS FOR BASIS OF PAYMENT.

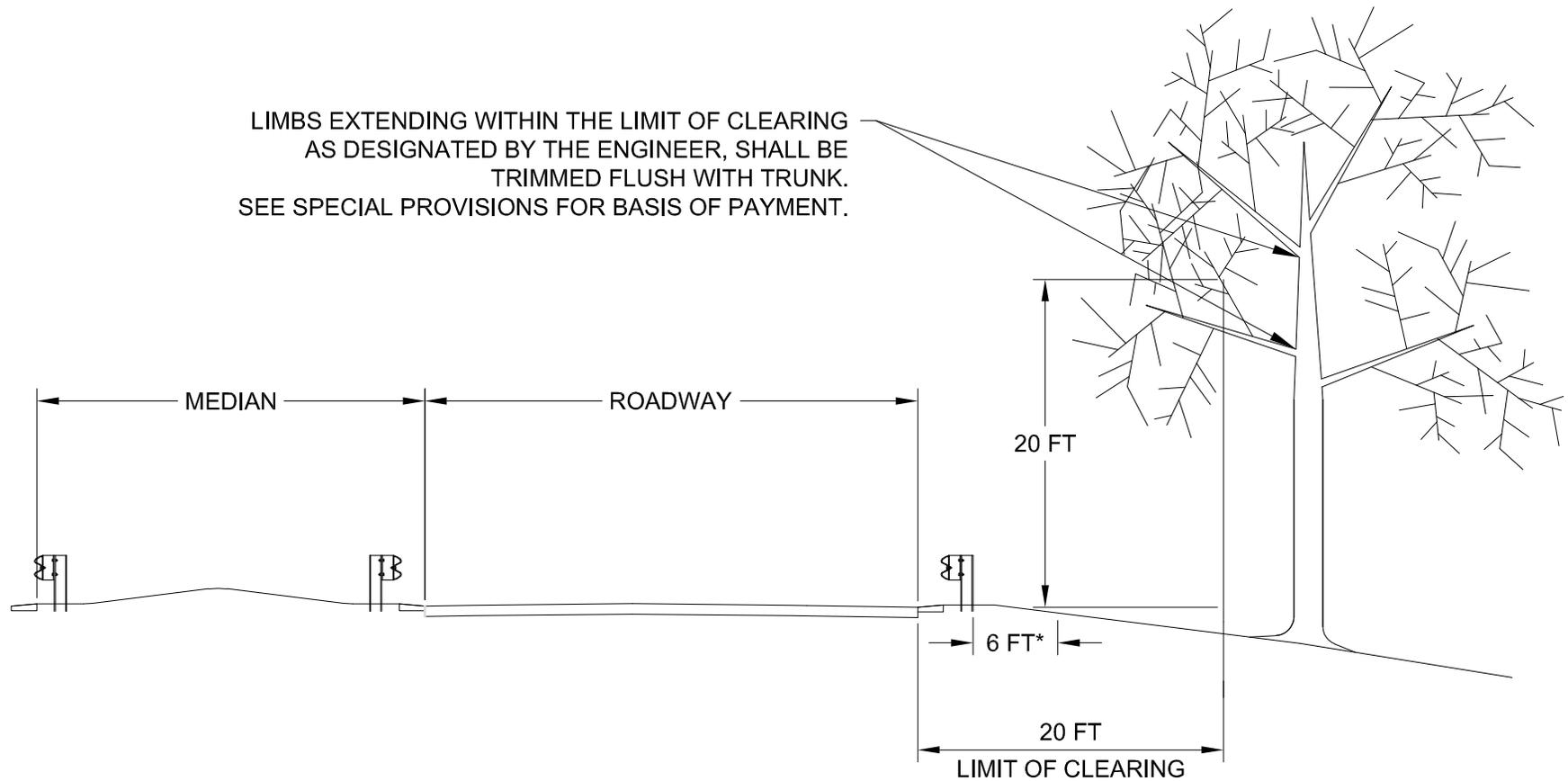

TYPICAL SECTION - ITEM 102.1
TREE TRIMMING
 NOT TO SCALE

NOTE: * WITHIN THE BUFFER ZONE OF BORDERING VEGETATED WETLANDS, TREE TRIMMING SHALL BE LIMITED TO 6 FEET BEYOND THE GUARD RAIL.



TREE TRIMMING

DATE: 12/28/23
SCALE: NTS
PROJECT NO.: 612097
SHEET 2 OF 32



Maura Healey, Governor
Kimberley Driscoll, Lieutenant Governor
Monica Tibbitts-Nutt, Secretary & CEO
Jonathan L. Gulliver, Highway Administrator



ATTACHMENT D – Maps

Proposal No. 612097 - 129070
Wetland Resources Map

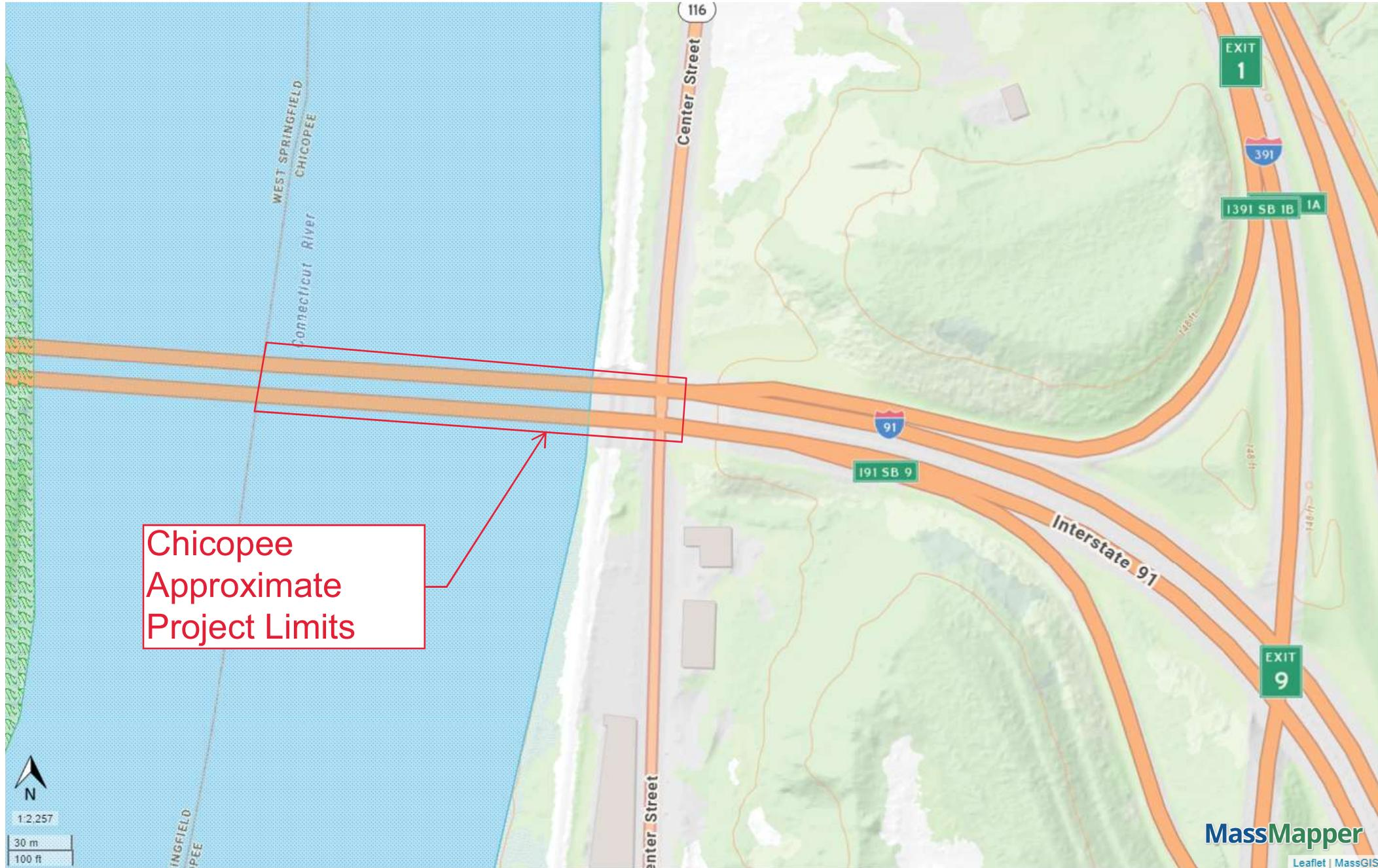

DEP Wetlands Detailed With Outlines

- Barrier Beach System
- Barrier Beach-Deep Marsh
- Barrier Beach-Wooded Swamp Mixed Trees
- Barrier Beach-Coastal Beach
- Barrier Beach-Coastal Dune
- Barrier Beach-Marsh
- Barrier Beach-Salt Marsh
- Barrier Beach-Shrub Swamp
- Barrier Beach-Wooded Swamp Coniferous
- Barrier Beach-Wooded Swamp Deciduous
- Bog
- Coastal Bank Bluff or Sea Cliff
- Coastal Beach
- Coastal Dune
- Cranberry Bog
- Deep Marsh
- Barrier Beach-Open Water
- Open Water
- Rocky Intertidal Shore
- Salt Marsh
- Shallow Marsh Meadow or Fen
- Shrub Swamp
- Tidal Flat
- Wooded Swamp Coniferous
- Wooded Swamp Deciduous
- Wooded Swamp Mixed Trees

Proposal No. 612097 - 129070
BLSF Map

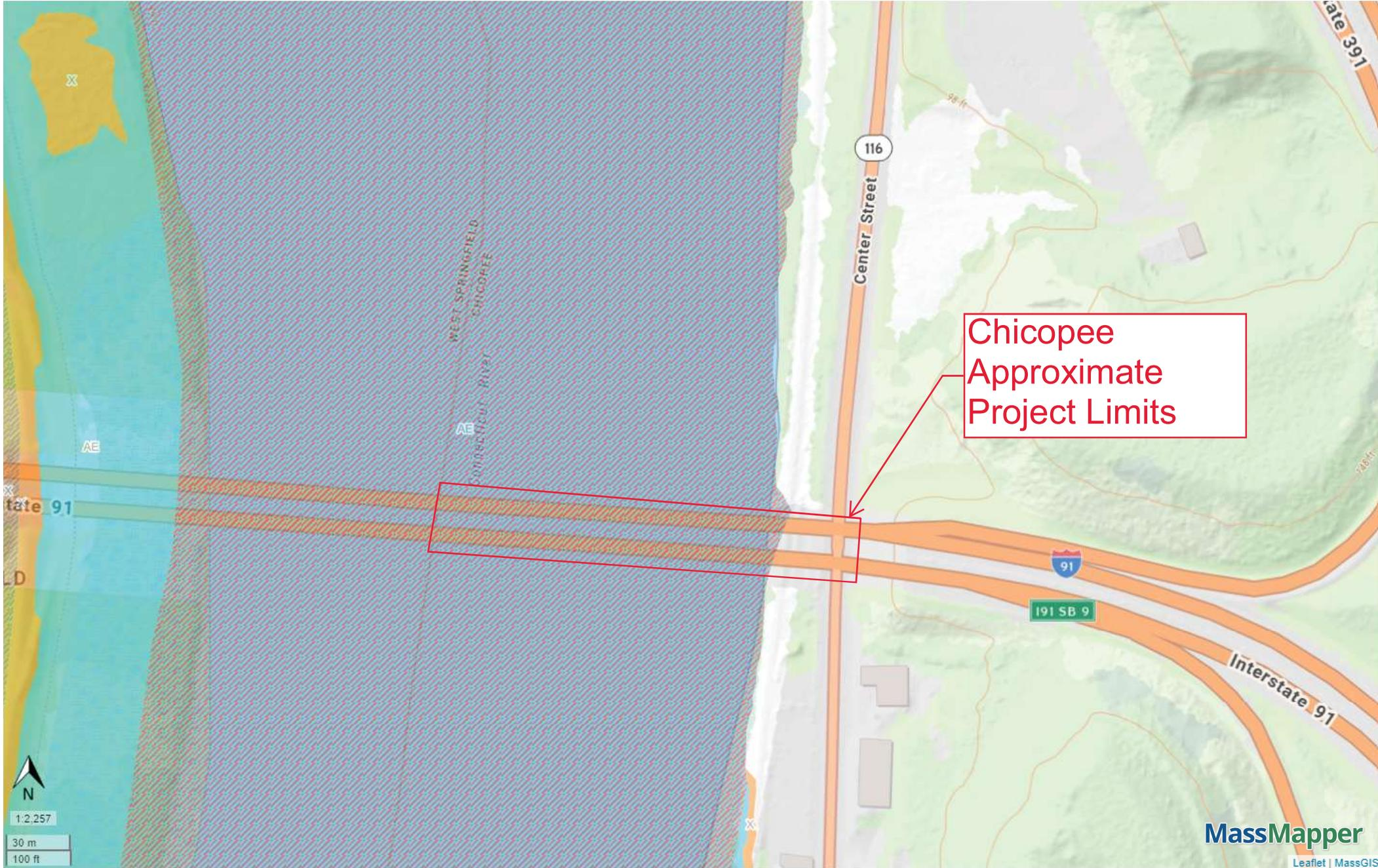

FEMA National Flood Hazard Layer Polygons

- 1% Annual Chance Flood Hazard
- Regulatory Floodway
- Area of Undetermined Flood Hazard
- 0.2% Annual Chance Flood Hazard
- Area with Reduced Risk Due to Levee
- Area Not Included

Chicopee
Approximate
Project Limits

Signature: *Paula K. Simmons*

Email: paula.simmons@dot.state.ma.us

Proposal No. 612097 - 129070

THIS PAGE IS INTENTIONALLY LEFT BLANK

DOCUMENT A00851

**MASSACHUSETTS WETLANDS
PROTECTION ACT**

DETERMINATION OF APPLICABILITY

THIS PAGE INTENTIONALLY LEFT BLANK



Massachusetts Department of Environmental Protection
 Bureau of Water Resources - Wetlands
WPA Form 2 – Determination of Applicability
 Massachusetts Wetlands Protection Act M.G.L. c. 131, §40

West
 Springfield
 Municipality

A. General Information

Important:
 When filling out forms on the computer, use only the tab key to move your cursor - do not use the return key.

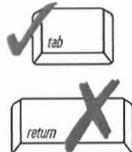

[How to find Latitude and Longitude](#)

[and how to convert to decimal degrees](#)

From:

West Springfield Conservation Commission
 Conservation Commission

To: Applicant

MassDOT District II Patricia Leaenworth,
 District Highway Director
 811 N. King Street
 Mailing Address
 Northampton MA 01060
 City/Town State Zip Code
 (413) 857-3311 (Billie Li project Manager)
 Phone Number
 Billie.m.li@dot.state.ma.us
 Email Address

Property Owner (if different from applicant):

Name
 Mailing Address
 City/Town State Zip Code
 Phone Number
 Email Address (if known)

1. Project Location:

Interstate 91 (I-91)
 Street Address
 42.13571
 Latitude (Decimal Degrees Format with 5 digits after decimal e.g. XX.XXXXX)
 NA Linear
 Assessors Map/Plat Number

West Springfield
 City/Town
 -72.61524
 Longitude (Decimal Degrees Format with 5 digits after decimal e.g. -XX.XXXXX)
 NA
 Parcel/Lot Number

2. Date Request Filed:

August 9, 2024

B. Determination

Pursuant to the authority of M.G.L. c. 131, § 40, the Conservation Commission considered your Request for Determination of Applicability, with its supporting documentation, and made the following Determination.

Project Description (if applicable):

I-91 Between mile marker 8.5 to 10.5 including Connecticut River Bridge. Project scope includes roadway & bridge deck resurfacing, bridge deck repairs, intallation of asphalt berms, cleaning of paved waterways, installation of new paved waterway connectors, clearing roadway side slopes, removal of build up material on shoulders to restore drainage, adjusting and rebuilding drainage structures and slective tree trimming.

Title and Date (or Revised Date if applicable) of Final Plans and Other Documents:

Request for Determination of Applicability package including Attachement C Design Plans	8/5/2024 Date
_____	_____
Title	Date
_____	_____
Title	Date
_____	_____



Massachusetts Department of Environmental Protection
Bureau of Water Resources - Wetlands

WPA Form 2 – Determination of Applicability

Massachusetts Wetlands Protection Act M.G.L. c. 131, §40

West
Springfield
Municipality

B. Determination (cont.)

The following Determination(s) is/are applicable to the proposed site and/or project relative to the Wetlands Protection Act and regulations:

Positive Determination

Note: No work within the jurisdiction of the Wetlands Protection Act may proceed until a final Order of Conditions (issued following submittal of a Notice of Intent or Abbreviated Notice of Intent) has been received from the issuing authority (i.e., Conservation Commission or the Department of Environmental Protection).

- 1. The area described on the referenced plan(s) is an area subject to jurisdiction under the Act. Removing, filling, dredging, or altering of the area requires the filing of a Notice of Intent.
- 2a. The boundary delineations of the following resource areas described on the referenced plan(s) are confirmed as accurate. Therefore, the resource area boundaries confirmed in this Determination are binding as to all decisions rendered pursuant to the Wetlands Protection Act and its regulations regarding such boundaries for as long as this Determination is valid.

- 2b. The boundaries of Wetlands Resource Area(s) and Buffer Zone(s) listed below are not confirmed by this Determination, regardless of whether such boundaries are contained on the plans attached to this Determination or to the Request for Determination.

- 3. The work described on referenced plan(s) and document(s) is within an area subject to jurisdiction under the Act and will remove, fill, dredge, or alter that area. Therefore, said work requires the filing of a Notice of Intent.
- 4. The work described on referenced plan(s) and document(s) is within the Buffer Zone and will alter an Area subject to jurisdiction under the Act. Therefore, said work requires the filing of a Notice of Intent
- 5. The area and/or work described on referenced plan(s) and document(s) is subject to review and approval by:

Name of Municipality

Pursuant to the following municipal wetland ordinance or bylaw:

Name

Ordinance or Bylaw Citation

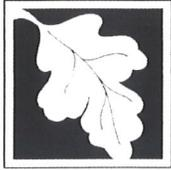

Massachusetts Department of Environmental Protection
 Bureau of Water Resources - Wetlands
WPA Form 2 – Determination of Applicability
 Massachusetts Wetlands Protection Act M.G.L. c. 131, §40

West
 Springfield
 Municipality

B. Determination (cont.)

- 6. The following area and/or work, if any, is subject to a municipal ordinance or bylaw but not subject to the Massachusetts Wetlands Protection Act:

- 7. If a Notice of Intent is filed for the work in the Riverfront Area described on referenced plan(s) and document(s), which includes all or part of the work described in the Request, the applicant must consider the following alternatives. (Refer to the wetland regulations at 10.58(4)(c) 2. for more information about the scope of alternatives requirements):

- Alternatives limited to the lot on which the project is located.
- Alternatives limited to the lot on which the project is located, the subdivided lots, and any adjacent lots formerly or presently owned by the same owner.
- Alternatives limited to the original parcel on which the project is located, the subdivided parcels, any adjacent parcels, and any other land which can reasonably be obtained within the municipality.
- Alternatives extend to any sites which can reasonably be obtained within the appropriate region of the state.

Negative Determination

Note: No further action under the Wetlands Protection Act is required by the applicant. However, if the Department is requested to issue a Superseding Determination of Applicability, work may not proceed on this project unless the Department fails to act on such request within 35 days of the date the request is post-marked for certified mail or hand delivered to the Department. Work may then proceed at the owner's risk only upon notice to the Department and to the Conservation Commission. Requirements for requests for Superseding Determinations are listed at the end of this document.

- 1. The area described in the Request is not an area subject to jurisdiction under the Act or the Buffer Zone.
- 2. The work described in the Request is within an area subject to jurisdiction under the Act, but will not remove, fill, dredge, or alter that area. Therefore, said work does not require the filing of a Notice of Intent.
- 3. The work described in the Request is within the Buffer Zone, as defined in the regulations, but will not alter an Area subject to jurisdiction under the Act. Therefore, said work does not require the filing of a Notice of Intent, subject to the following conditions (if any).

- 4. The work described in the Request is not within an Area subject to jurisdiction under the Act (including the Buffer Zone). Therefore, said work does not require the filing of a Notice of Intent, unless and until said work alters an Area subject to jurisdiction under the Act.

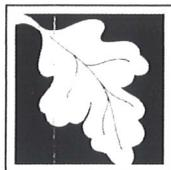

Massachusetts Department of Environmental Protection
Bureau of Water Resources - Wetlands

WPA Form 2 – Determination of Applicability

Massachusetts Wetlands Protection Act M.G.L. c. 131, §40

West
Springfield
Municipality

B. Determination (cont.)

- 5. The area described in the Request is subject to jurisdiction under the Act. Since the work described therein meets the requirements for the following exemption, as specified in the Act and the regulations, no Notice of Intent is required:

310 CMR 10.02(2)(a)1. & 2. and 310CMR 10.02(2)(b)1.&2.

Exempt Activity (site applicable statutory/regulatory provisions)

- 6. The area and/or work described in the Request is not subject to additional review and approval by:

Name of Municipality

Pursuant to a municipal wetlands' ordinance or bylaw.

Name

Ordinance or Bylaw Citation

C. Authorization

This Determination is issued to the applicant and delivered as follows:

- By hand delivery on

Date

- By certified mail, return receipt request on

SEPTEMBER 2024
Date

9171 9690 0935 0250 5669 64

Certified Mail Number

A copy of this Determination has been sent on the same date, considered the date of issuance, to the appropriate DEP Regional Office and the property owner (if not the applicant) in the manner as follows:

DEP

- By eDEP DOA Submittal Platform (Attach this form and supporting documents)

- By USPS mail

Date

- By hand delivery

Date

Property Owner (if not applicant)

- By mail

Date

- By hand delivery

Date

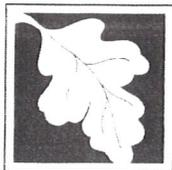

Massachusetts Department of Environmental Protection
Bureau of Water Resources - Wetlands

WPA Form 2 – Determination of Applicability

Massachusetts Wetlands Protection Act M.G.L. c. 131, §40

West
Springfield
Municipality

C. Authorization (cont.)

This Determination is valid for **three years** from the date of issuance (except Determinations for Vegetation Management Plans which are valid for the duration of the Plan). This Determination does not relieve the applicant from complying with all other applicable federal, state, or local statutes, ordinances, bylaws, or regulations.

This Determination must be signed by a majority of the Conservation Commission. As noted above, a copy must be sent to the appropriate DEP Regional Office (see <https://www.mass.gov/service-details/massdep-regional-offices-by-community>) and the property owner (if different from the applicant) on the same date that the Applicant is issued this Determination.

Issuing Authority

Signatures:

Signature

Signature

Signature

Signature

Signature

Signature

Signature

Printed Name

Printed Name

Printed Name

Printed Name

Printed Name

Printed Name

Printed Name

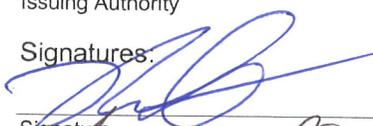
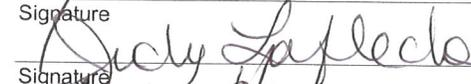
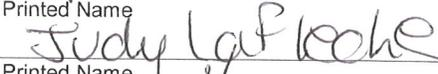
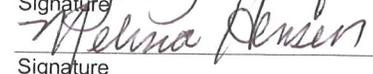
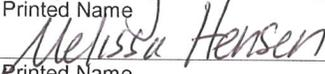
	
Signature	Printed Name
	
Signature	Printed Name
	
Signature	Printed Name
	
Signature	Printed Name
Signature	Printed Name
Signature	Printed Name

D. Appeals

The applicant, owner, any person aggrieved by this Determination, any owner of land abutting the land upon which the proposed work is to be done, or any ten residents of the city or town in which such land is located, are hereby notified of their right to request the appropriate Department of Environmental Protection Regional Office (see <https://www.mass.gov/service-details/massdep-regional-offices-by-community>) to issue a Superseding Determination of Applicability. The request must be made by certified mail or hand delivery to the Department, with the appropriate filing fee and Fee Transmittal Form (see Request for Departmental Action Fee Transmittal Form) as provided in 310 CMR 10.03(7) within ten business days from the date of issuance of this Determination. A copy of the request shall at the same time be sent by certified mail or hand delivery to the Conservation Commission and to the applicant if he/she is not the appellant. The request shall state clearly and concisely the objections to the Determination which is being appealed. To the extent that the Determination is based on a municipal ordinance or bylaw and not on the Massachusetts Wetlands Protection Act or regulations, the Department of Environmental Protection has no appellate jurisdiction.



Massachusetts Department of Environmental Protection
 Bureau of Resource Protection - Wetlands
Request for Departmental Action Fee
Transmittal Form

DEP File Number:

Provided by DEP

Massachusetts Wetlands Protection Act M.G.L. c. 131, §40

A. Request Information

1. Location of Project

a. Street Address	b. City/Town, Zip
c. Check number	d. Fee amount

2. Person or party making request (if appropriate, name the citizen group's representative):

Name

Mailing Address

City/Town State Zip Code

Phone Number Fax Number (if applicable)

3. Applicant (as shown on Determination of Applicability (Form 2), Order of Resource Area Delineation (Form 4B), Order of Conditions (Form 5), Restoration Order of Conditions (Form 5A), or Notice of Non-Significance (Form 6)):

Name

Mailing Address

City/Town State Zip Code

Phone Number Fax Number (if applicable)

4. DEP File Number:

Important:
 When filling out forms on the computer, use only the tab key to move your cursor - do not use the return key.



B. Instructions

1. When the Departmental action request is for (check one):

- Superseding Order of Conditions – Fee: \$120 (single family house projects) or \$245 (all other projects)
- Superseding Determination of Applicability – Fee: \$120
- Superseding Order of Resource Area Delineation – Fee: \$120

Send this form and check or money order, payable to the *Commonwealth of Massachusetts*, to:

Department of Environmental Protection
 Box 4062
 Boston, MA 02211

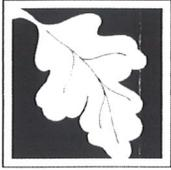

Massachusetts Department of Environmental Protection
Bureau of Resource Protection - Wetlands
Request for Departmental Action Fee
Transmittal Form

DEP File Number:

Provided by DEP

Massachusetts Wetlands Protection Act M.G.L. c. 131, §40

B. Instructions (cont.)

2. On a separate sheet attached to this form, state clearly and concisely the objections to the Determination or Order which is being appealed. To the extent that the Determination or Order is based on a municipal bylaw, and not on the Massachusetts Wetlands Protection Act or regulations, the Department has no appellate jurisdiction.
3. Send a **copy** of this form and a **copy** of the check or money order with the Request for a Superseding Determination or Order by certified mail or hand delivery to the appropriate DEP Regional Office (see <https://www.mass.gov/service-details/massdep-regional-offices-by-community>).
4. A copy of the request shall at the same time be sent by certified mail or hand delivery to the Conservation Commission and to the applicant, if he/she is not the appellant.

THIS PAGE IS INTENTIONALLY LEFT BLANK



Massachusetts Department of Environmental Protection
Bureau of Water Resources - Wetlands
WPA Form 2 – Determination of Applicability
Massachusetts Wetlands Protection Act M.G.L. c. 131, §40

Chicopee
Municipality

A. General Information

Important:
When filling out forms on the computer, use only the tab key to move your cursor - do not use the return key.

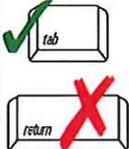

From:

Chicopee (File RDA 24-005)
Conservation Commission

To: Applicant

Patricia Leavenworth (MassDOT)
Name
811 North King Street
Mailing Address
Northampton MA 01060
City/Town State Zip Code
857-286-3311
Phone Number
Billie.m.li@dot.state.ma.us
Email Address

Property Owner (if different from applicant):

Name
Mailing Address
City/Town State Zip Code
Phone Number
Email Address (if known)

1. Project Location:

I-91
Street Address
42.13571
Latitude (Decimal Degrees Format with 5 digits after decimal e.g. XX.XXXXX)
N/A
Assessors Map/Plat Number

Chicopee
City/Town
-72.61524
Longitude (Decimal Degrees Format with 5 digits after decimal e.g. -XX.XXXXX)
N/A
Parcel/Lot Number

[How to find Latitude and Longitude](#)

[and how to convert to decimal degrees](#)

2. Date Request Filed:

August 8, 2024

B. Determination

Pursuant to the authority of M.G.L. c. 131, § 40, the Conservation Commission considered your Request for Determination of Applicability, with its supporting documentation, and made the following Determination.

Project Description (if applicable):

Work within the existing ROW for Interstate 91. Work includes roadway and bridge resurfacing, bridge deck repairs, clearing roadway side slopes, adjusting and/or rebuilding drainage structures, selective tree trimming, and the use of erosion control and sedimentation control measures. Work will occur within Riverfront Area and Bordering Land Subject to Flooding.

Title and Date (or Revised Date if applicable) of Final Plans and Other Documents:

I-91 West Springfield/Chicopee	January 3, 2023
Title	Date
_____	_____
Title	Date
_____	_____
Title	Date
_____	_____

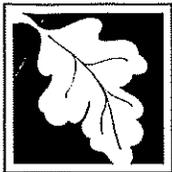

Massachusetts Department of Environmental Protection
Bureau of Water Resources - Wetlands

WPA Form 2 – Determination of Applicability

Massachusetts Wetlands Protection Act M.G.L. c. 131, §40

Chicopee
Municipality

B. Determination (cont.)

The following Determination(s) is/are applicable to the proposed site and/or project relative to the Wetlands Protection Act and regulations:

Positive Determination

Note: No work within the jurisdiction of the Wetlands Protection Act may proceed until a final Order of Conditions (issued following submittal of a Notice of Intent or Abbreviated Notice of Intent) has been received from the issuing authority (i.e., Conservation Commission or the Department of Environmental Protection).

- 1. The area described on the referenced plan(s) is an area subject to jurisdiction under the Act. Removing, filling, dredging, or altering of the area requires the filing of a Notice of Intent.
- 2a. The boundary delineations of the following resource areas described on the referenced plan(s) are confirmed as accurate. Therefore, the resource area boundaries confirmed in this Determination are binding as to all decisions rendered pursuant to the Wetlands Protection Act and its regulations regarding such boundaries for as long as this Determination is valid.

- 2b. The boundaries of Wetlands Resource Area(s) and Buffer Zone(s) listed below are not confirmed by this Determination, regardless of whether such boundaries are contained on the plans attached to this Determination or to the Request for Determination.

- 3. The work described on referenced plan(s) and document(s) is within an area subject to jurisdiction under the Act and will remove, fill, dredge, or alter that area. Therefore, said work requires the filing of a Notice of Intent.
- 4. The work described on referenced plan(s) and document(s) is within the Buffer Zone and will alter an Area subject to jurisdiction under the Act. Therefore, said work requires the filing of a Notice of Intent
- 5. The area and/or work described on referenced plan(s) and document(s) is subject to review and approval by:

Name of Municipality

Pursuant to the following municipal wetland ordinance or bylaw:

Name

Ordinance or Bylaw Citation



Massachusetts Department of Environmental Protection
 Bureau of Water Resources - Wetlands

WPA Form 2 – Determination of Applicability

Massachusetts Wetlands Protection Act M.G.L. c. 131, §40

Chicopee
 Municipality

B. Determination (cont.)

- 6. The following area and/or work, if any, is subject to a municipal ordinance or bylaw but not subject to the Massachusetts Wetlands Protection Act:

- 7. If a Notice of Intent is filed for the work in the Riverfront Area described on referenced plan(s) and document(s), which includes all or part of the work described in the Request, the applicant must consider the following alternatives. (Refer to the wetland regulations at 10.58(4)(c) 2. for more information about the scope of alternatives requirements):

- Alternatives limited to the lot on which the project is located.
- Alternatives limited to the lot on which the project is located, the subdivided lots, and any adjacent lots formerly or presently owned by the same owner.
- Alternatives limited to the original parcel on which the project is located, the subdivided parcels, any adjacent parcels, and any other land which can reasonably be obtained within the municipality.
- Alternatives extend to any sites which can reasonably be obtained within the appropriate region of the state.

Negative Determination

Note: No further action under the Wetlands Protection Act is required by the applicant. However, if the Department is requested to issue a Superseding Determination of Applicability, work may not proceed on this project unless the Department fails to act on such request within 35 days of the date the request is post-marked for certified mail or hand delivered to the Department. Work may then proceed at the owner's risk only upon notice to the Department and to the Conservation Commission. Requirements for requests for Superseding Determinations are listed at the end of this document.

- 1. The area described in the Request is not an area subject to jurisdiction under the Act or the Buffer Zone.
- 2. The work described in the Request is within an area subject to jurisdiction under the Act, but will not remove, fill, dredge, or alter that area. Therefore, said work does not require the filing of a Notice of Intent.
- 3. The work described in the Request is within the Buffer Zone, as defined in the regulations, but will not alter an Area subject to jurisdiction under the Act. Therefore, said work does not require the filing of a Notice of Intent, subject to the following conditions (if any).

- 4. The work described in the Request is not within an Area subject to jurisdiction under the Act (including the Buffer Zone). Therefore, said work does not require the filing of a Notice of Intent, unless and until said work alters an Area subject to jurisdiction under the Act.



Massachusetts Department of Environmental Protection
Bureau of Water Resources - Wetlands

WPA Form 2 – Determination of Applicability

Massachusetts Wetlands Protection Act M.G.L. c. 131, §40

Chicopee
Municipality

B. Determination (cont.)

- 5. The area described in the Request is subject to jurisdiction under the Act. Since the work described therein meets the requirements for the following exemption, as specified in the Act and the regulations, no Notice of Intent is required:

310 CMR 10.02 2 (b) 2 n,p

Exempt Activity (site applicable statutory/regulatory provisions)

- 6. The area and/or work described in the Request is not subject to additional review and approval by:

Name of Municipality

Pursuant to a municipal wetlands' ordinance or bylaw.

Name

Ordinance or Bylaw Citation

C. Authorization

This Determination is issued to the applicant and delivered as follows:

- By hand delivery on
- By certified mail, return receipt request on

Date

Date

SEPTEMBER 10, 2024

Certified Mail Number

7022 0410 0002 1871 4595

A copy of this Determination has been sent on the same date, considered the date of issuance, to the appropriate DEP Regional Office and the property owner (if not the applicant) in the manner as follows:

DEP

- By [eDEP DOA Submittal Platform](#) (Attach this form and supporting documents)

- By USPS mail
- By hand delivery

Date

Date

SEPTEMBER 10, 2024

Property Owner (if not applicant)

- By mail
- By hand delivery

Date

Date



Massachusetts Department of Environmental Protection
 Bureau of Water Resources - Wetlands

WPA Form 2 – Determination of Applicability

Massachusetts Wetlands Protection Act M.G.L. c. 131, §40

Chicopee
 Municipality

C. Authorization (cont.)

This Determination is valid for **three years** from the date of issuance (except Determinations for Vegetation Management Plans which are valid for the duration of the Plan). This Determination does not relieve the applicant from complying with all other applicable federal, state, or local statutes, ordinances, bylaws, or regulations.

This Determination must be signed by a majority of the Conservation Commission. As noted above, a copy must be sent to the appropriate DEP Regional Office (see <https://www.mass.gov/service-details/massdep-regional-offices-by-community>) and the property owner (if different from the applicant) on the same date that the Applicant is issued this Determination.

Chicopee (File RDA 24-005)

Issuing Authority

Signatures:

	Celeste Donovan
Signature	Printed Name
	Charles Payne
Signature	Printed Name
	Meghan Balakier
Signature	Printed Name
	Richard Valcourt
Signature	Printed Name
	Bianca Thomas
Signature	Printed Name
	Barbara Chamberlain
Signature	Printed Name
Signature	Sharon Balcom
Signature	Printed Name

D. Appeals

The applicant, owner, any person aggrieved by this Determination, any owner of land abutting the land upon which the proposed work is to be done, or any ten residents of the city or town in which such land is located, are hereby notified of their right to request the appropriate Department of Environmental Protection Regional Office (see <https://www.mass.gov/service-details/massdep-regional-offices-by-community>) to issue a Superseding Determination of Applicability. The request must be made by certified mail or hand delivery to the Department, with the appropriate filing fee and Fee Transmittal Form (see Request for Departmental Action Fee Transmittal Form) as provided in 310 CMR 10.03(7) within ten business days from the date of issuance of this Determination. A copy of the request shall at the same time be sent by certified mail or hand delivery to the Conservation Commission and to the applicant if he/she is not the appellant. The request shall state clearly and concisely the objections to the Determination which is being appealed. To the extent that the Determination is based on a municipal ordinance or bylaw and not on the Massachusetts Wetlands Protection Act or regulations, the Department of Environmental Protection has no appellate jurisdiction.



Massachusetts Department of Environmental Protection
Bureau of Resource Protection - Wetlands
Request for Departmental Action Fee
Transmittal Form

DEP File Number:

Provided by DEP

Massachusetts Wetlands Protection Act M.G.L. c. 131, §40

A. Request Information

1. Location of Project

a. Street Address	b. City/Town, Zip
c. Check number	d. Fee amount

2. Person or party making request (if appropriate, name the citizen group's representative):

Name

Mailing Address

City/Town	State	Zip Code
Phone Number	Fax Number (if applicable)	

3. Applicant (as shown on Determination of Applicability (Form 2), Order of Resource Area Delineation (Form 4B), Order of Conditions (Form 5), Restoration Order of Conditions (Form 5A), or Notice of Non-Significance (Form 6)):

Name

Mailing Address

City/Town	State	Zip Code
Phone Number	Fax Number (if applicable)	

4. DEP File Number:

B. Instructions

1. When the Departmental action request is for (check one):

- Superseding Order of Conditions – Fee: \$120 (single family house projects) or \$245 (all other projects)
- Superseding Determination of Applicability – Fee: \$120
- Superseding Order of Resource Area Delineation – Fee: \$120

Send this form and check or money order, payable to the *Commonwealth of Massachusetts*, to:

Department of Environmental Protection
Box 4062
Boston, MA 02211

Important:
When filling out forms on the computer, use only the tab key to move your cursor - do not use the return key.

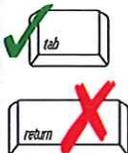



Massachusetts Department of Environmental Protection

Bureau of Resource Protection - Wetlands

**Request for Departmental Action Fee
Transmittal Form**

DEP File Number:

Provided by DEP

Massachusetts Wetlands Protection Act M.G.L. c. 131, §40

B. Instructions (cont.)

2. On a separate sheet attached to this form, state clearly and concisely the objections to the Determination or Order which is being appealed. To the extent that the Determination or Order is based on a municipal bylaw, and not on the Massachusetts Wetlands Protection Act or regulations, the Department has no appellate jurisdiction.
3. Send a **copy** of this form and a **copy** of the check or money order with the Request for a Superseding Determination or Order by certified mail or hand delivery to the appropriate DEP Regional Office (see <https://www.mass.gov/service-details/massdep-regional-offices-by-community>).
4. A copy of the request shall at the same time be sent by certified mail or hand delivery to the Conservation Commission and to the applicant, if he/she is not the appellant.

THIS PAGE IS INTENTIONALLY LEFT BLANK

DOCUMENT A00870

**UNITED STATES DEPARTMENT OF THE INTERIOR
FISH AND WILDLIFE SERVICE**

CONSISTENCY LETTER

THIS PAGE IS INTENTIONALLY LEFT BLANK



United States Department of the Interior



FISH AND WILDLIFE SERVICE
New England Ecological Services Field Office
70 Commercial Street, Suite 300
Concord, NH 03301-5094
Phone: (603) 223-2541 Fax: (603) 223-0104

In Reply Refer To:

06/26/2024 14:43:15 UTC

Project code: 2024-0108439

Project Name: 612097 - WEST SPRINGFIELD- CHICOPEE- INTERSTATE MAINTENANCE AND RELATED WORK ON I-91

Subject: Consistency letter for the '612097 - WEST SPRINGFIELD- CHICOPEE- INTERSTATE MAINTENANCE AND RELATED WORK ON I-91' project under the amended February 5, 2018, FHWA, FRA, FTA Programmatic Biological Opinion (dated March 23, 2023) for Transportation Projects within the Range of the Indiana Bat and Northern Long-eared Bat (NLEB).

To whom it may concern:

The U.S. Fish and Wildlife Service (Service) has received your request dated June 26, 2024 to verify that the **612097 - WEST SPRINGFIELD- CHICOPEE- INTERSTATE MAINTENANCE AND RELATED WORK ON I-91** (Proposed Action) may rely on the amended February 5, 2018, FHWA, FRA, FTA Programmatic Biological Opinion (dated March 23, 2023) for Transportation Projects within the Range of the Indiana Bat and Northern Long-eared Bat (PBO) to satisfy requirements under section 7(a)(2) of the Endangered Species Act of 1973 (ESA) (87 Stat.884, as amended; 16 U.S.C. 1531 *et seq.*).

Based on the information you provided (Project Description shown below), you have determined that the Proposed Action will have no effect on the endangered Indiana bat (*Myotis sodalis*) or the endangered northern long-eared bat (*Myotis septentrionalis*). If the Proposed Action is not modified, **no consultation is required for these two species**. If the Proposed Action is modified, or new information reveals that it may affect the Indiana bat and/or northern long-eared bat in a manner or to an extent not considered in the PBO, further review to conclude the requirements of ESA section 7(a)(2) may be required.

For Proposed Actions that include bridge/culvert or structure removal, replacement, and/or maintenance activities:

If your initial bridge/culvert or structure assessment failed to detect Indiana bats and/or NLEBs use or occupancy, yet later detected prior to, or during construction, please submit the Post Assessment Discovery of Bats at Bridge/Culvert or Structure Form (User Guide Appendix E) to this Service Office within 2 working days of the incident. In these instances, potential incidental

take of Indiana bats and/or NLEBs may be exempted provided that the take is reported to the Service.

If the Proposed Action may affect any other federally-listed or proposed species and/or designated critical habitat, additional consultation between the lead Federal action agency and this Service Office is required. If the proposed action has the potential to take bald or golden eagles, additional coordination with the Service under the Bald and Golden Eagle Protection Act may also be required. In either of these circumstances, please advise the lead Federal action agency accordingly.

The following species may occur in your project area and **are not** covered by this determination:

- Monarch Butterfly *Danaus plexippus* Candidate
- Tricolored Bat *Perimyotis subflavus* Proposed Endangered

PROJECT DESCRIPTION

The following project name and description was collected in IPaC as part of the endangered species review process.

NAME

612097 - WEST SPRINGFIELD- CHICOPEE- INTERSTATE MAINTENANCE AND RELATED WORK ON I-91

DESCRIPTION

612097 - WEST SPRINGFIELD- CHICOPEE- INTERSTATE MAINTENANCE AND RELATED WORK ON I-91

Pavement preservation on a section of I-91 in West Springfield and Chicopee. Related work includes the preservation of other assets within the project limits.

Monarch Butterfly: Candidate Species only, no conservation measures at this time.

Tricolor Bat: Proposed Endangered Species only, no conservation measures at this time.

The approximate location of the project can be viewed in Google Maps: <https://www.google.com/maps/@42.1385427,-72.63477222229372,14z>

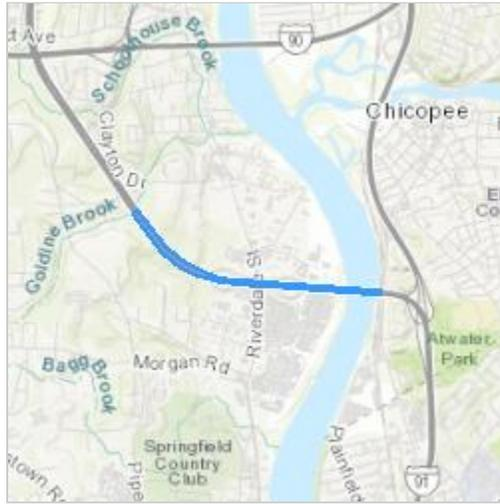

DETERMINATION KEY RESULT

Based on the information you provided, you have determined that the Proposed Action will have no effect on the endangered Indiana bat and/or the endangered northern long-eared bat.

Therefore, no consultation with the U.S. Fish and Wildlife Service pursuant to Section 7(a)(2) of the Endangered Species Act of 1973 (ESA) (87 Stat. 884, as amended 16 U.S.C. 1531 *et seq.*) is required for these two species.

QUALIFICATION INTERVIEW

1. Is the project within the range of the Indiana bat^[1]?

[1] See [Indiana bat species profile](#)

Automatically answered

No

2. Is the project within the range of the northern long-eared bat^[1]?

[1] See [northern long-eared bat species profile](#)

Automatically answered

Yes

3. [Semantic] Does your proposed action intersect an area where Indiana bats and northern long-eared bats are not likely to occur?

Automatically answered

Yes

DETERMINATION KEY DESCRIPTION: FHWA, FRA, FTA PROGRAMMATIC CONSULTATION FOR TRANSPORTATION PROJECTS AFFECTING NLEB OR INDIANA BAT

This key was last updated in IPaC on October 30, 2023. Keys are subject to periodic revision.

This decision key is intended for projects/activities funded or authorized by the Federal Highway Administration (FHWA), Federal Railroad Administration (FRA), and/or Federal Transit Administration (FTA), which may require consultation with the U.S. Fish and Wildlife Service (Service) under Section 7 of the Endangered Species Act (ESA) for the endangered **Indiana bat** (*Myotis sodalis*) and the endangered **northern long-eared bat** (NLEB) (*Myotis septentrionalis*).

This decision key should only be used to verify project applicability with the Service's [amended February 5, 2018, FHWA, FRA, FTA Programmatic Biological Opinion \(dated March 23, 2023\) for Transportation Projects](#). The programmatic biological opinion covers limited transportation activities that may affect either bat species, and addresses situations that are both likely and not likely to adversely affect either bat species. This decision key will assist in identifying the effect of a specific project/activity and applicability of the programmatic consultation. The programmatic biological opinion is not intended to cover all types of transportation actions. Activities outside the scope of the programmatic biological opinion, or that may affect ESA-listed species other than the Indiana bat or NLEB, or any designated critical habitat, may require additional ESA Section 7 consultation.

IPAC USER CONTACT INFORMATION

Agency: Massachusetts Department of Transportation

Name: Ian Battles

Address: 10 Park Plaza

City: Boston

State: MA

Zip: 02116

Email: ian.h.battles@dot.state.ma.us

Phone: 8572623378

LEAD AGENCY CONTACT INFORMATION

Lead Agency: Federal Highway Administration

THIS PAGE IS INTENTIONALLY LEFT BLANK

DOCUMENT A00875

**POLICY DIRECTIVE P-22-001
AND
POLICY DIRECTIVE P-22-002**

THIS PAGE INTENTIONALLY LEFT BLANK

zoned property, schools, daycare facilities, playgrounds, parks, recreational areas, hospitals, elderly housing and convalescent facilities.

Temporary off-site storage of excavated soil from a MassDOT project is only permissible at a location approved and permitted by MassDOT. The temporary storage location should be located within the same municipality where the soil was excavated, where possible. Stockpiled soil must be securely covered, and appropriate measures must be taken to minimize fugitive dust and erosion.

Signs indicating the source of the soil, the date the soil was generated, and contact information must be erected and maintained until the stockpiled soils are transported to a disposal facility or reused on the project site.

Implementation Procedures

To ensure that off-site storage of excavated soils is managed properly on MassDOT projects, this policy requires the following:

1. Off-Site Stockpile Storage Locations

- a. The Contractor shall provide proposed off-site storage locations to the Engineer for approval at least 30 days prior to transporting soil off site. Off-site storage locations should be in the same municipality as the work site.
- b. The Contractor shall keep excavated soil on site until adequately characterized to the satisfaction of the Engineer.
- c. The Contractor shall provide notification of the approved off-site storage location to the local Board of Health and the Town Manager's/Mayor's Office at least 7-days prior to transporting soil off site.
- d. The Contractor shall provide the Engineer with at least 3-days' notice prior to transporting soil off site.
- e. For off-site storage locations on MassDOT property, the Contractor is required to obtain an Access Permit through the District Permits Office prior to storage of soil or other materials. MassDOT will issue these permits at no cost to the Contractor. Information to be submitted by the Contractor as part of the permit application shall include:
 - i. A description of material to be stored off-site, including available analytical data;
 - ii. A figure of the location with distances to residences and residential receptors; and
 - iii. Anticipated duration of temporary storage.
- f. Stockpile locations should not be within 500 feet of residential receptors (e.g., residential dwellings, residentially zoned property, schools, daycare facilities, playgrounds, parks, recreational areas, hospitals, elderly housing and convalescent facilities).
 - i. If the stockpile location must be within 500 feet of residential receptors, then soil must be less than RCS-1 (per 310 CMR 40.1600) and free of potentially hazardous or regulated items.

- g. For off-site storage locations on non-MassDOT property, the Contractor must notify the property owner(s) at least 7 days prior to transporting material.
- h. Exceptions to these rules will be reviewed by MassDOT and may be approved by the District Highway Director on a case-by-case basis.

2. Off-Site Stockpile Management

- a. The Contractor shall keep soil stockpiles on impermeable surfaces (e.g., asphalt or concrete) or on 10-mil polyethylene sheeting.
- b. The Contractor shall cover soil stockpiles with 10-mil polyethylene sheeting and surround with a berm made of hay bales, straw wattles, or similar.
 - i. Piles that are actively being worked on must be covered and re-secured at the end of the work shift.
- c. The Contractor shall label stockpiles with signs, including:
 - i. Location of origin (including any Release Tracking Numbers)
 - ii. Stockpile ID number (including MassDOT District office-assigned tracking ID, if different)
 - iii. Date of initial accumulation
 - iv. Applicable telephone numbers for the Contractor and MassDOT.
- d. The Contractor shall mitigate fugitive dust at storage locations under the direction of an appropriately trained/certified environmental professional.
- e. The Contractor shall remedy noncompliance with this policy within 48 hours.
- f. The Contractor shall remedy noncompliance with this policy on the SAME DAY for potentially hazardous material, as determined by the Engineer.
- g. The Contractor shall handle excavated soil according to federal, state, and local regulations.
- h. The Contractor shall use appropriate shipping documents for all movements of excavated soil on public roadways (e.g., Bill of Lading, Material Shipping Record, Manifest, Asbestos Waste Shipment Record, etc.).

THIS PAGE INTENTIONALLY LEFT BLANK



Number: P-22-002
Date: 9/23/22

POLICY DIRECTIVE

Jonathan Gulliver (signature on original)

HIGHWAY ADMINISTRATOR

Use of MassDOT Property for Staging and other Construction-Related Operations

Purpose

This Policy Directive is intended to address the use of MassDOT property by MassDOT Contractors for construction staging and other construction-related operations that are not specifically defined in the construction contract. Such use of MassDOT property will only be allowed if permitted by the District Office in accordance with 700 CMR 13.00, Approval of Access to MassDOT Highways and Other Property. This includes the use of MassDOT property for staging, laydown, and storage of equipment and materials, including soil excavated from a project site.

This Policy Directive requires the Contractor/applicant to obtain a Non-Vehicular Access Permit from MassDOT to use MassDOT property for these purposes.

This Policy Directive is effective immediately and applies to all MassDOT construction projects.

General Permit Considerations and Conditions

In addition to other normal MassDOT Access Permit procedures, MassDOT shall consider the following during the application, review, implementation and monitoring processes of Access Permits required by this Policy Directive:

- Storage and placement of the Contractor’s equipment and materials should not be allowed within the clear zone of the roadway.
- Stockpiled soils should not be located within 500 feet of residential receptors, as defined herein to include, but not be limited to, residential dwellings, residentially zoned property, schools, daycare facilities, playgrounds, parks, recreational areas, hospitals, elderly housing and convalescent facilities.
- The Contractor/applicant shall identify the access/egress locations of the proposed storage areas. MassDOT will only approve locations determined to be safe for roadway users, construction workers and the general public.
- The Contractor may be required to submit a Traffic Management Plan and/or Lighting Plan for MassDOT review and approval as part of the permit application, depending on the proposed use of the area.

- The Contractor shall submit the permit application through MassDOT's online State Highway Access Permit System (SHAPS).
- MassDOT will waive the permit application fee for any application received from a MassDOT Contractor for any permit required by this Policy Directive and will waive any subsequent amendment and extension fees that may otherwise be required.
- MassDOT will review the permit application in accordance with applicable standard procedures and will apply standard permit terms and conditions, as necessary.
- The Resident Engineer will verify that the permit is approved before allowing the Contractor to use the affected area for the requested purpose.
- Areas permitted are for use by the approved applicant only and are not to be shared with or used by other vendors. Subcontractors specifically engaged with the applicant working on the specific MassDOT project will be allowed to use the area in accordance with the terms of the permit.
- Permits are issued on an annual basis and will require the Contractor to file for an extension each year to continue use.

Exemptions from Permit Requirements

Equipment and materials being used for active construction operations and located within the work zone of the construction contract are exempt from this permit requirement, provided they do not interfere with the safety or operation of the roadway or the work zone. Examples of these types of exempt uses are:

- Equipment and materials parked or stored within a protected (barriered) work zone.
- Materials placed in the work zone prior to same-day installation or use.
- Soils excavated temporarily and scheduled to be replaced, such as for trenching operations or for installation of drainage structures.

DOCUMENT B00420

PROPOSAL

WEST SPRINGFIELD - CHICOPEE

For: **Pavement and Bridge Preservation on I-91**

COMMONWEALTH OF MASSACHUSETTS

LOCATION

The work referred to herein is in the Cities of WEST SPRINGFIELD – CHICOPEE in Hampden County, in the Commonwealth of Massachusetts, and is shown by the locus map (Document 00331) in the Proposal Pamphlet, the work locations extend as follows:

I-91

Beginning – MM 8.518, Chicopee

Ending –MM 10.504, West Springfield

The contract prices shall include the furnishing of all materials (except as otherwise herein specified), the performing of all the labor requisite or proper, the providing of all necessary machinery, tools, apparatus and other means of construction, the doing of all the abovementioned work in the manner set forth, described and shown in the specifications and on the drawings for the work, and in the form of contract, and the completion thereof within **590 CALENDAR DAYS** upon receipt of a Notice to Proceed, except that if the completion date falls between December 1 and March 15 then the same number of days beyond December 1st will be extended after March 15th.

The Work of this project is described by the following Items and quantities.

THIS PAGE INTENTIONALLY LEFT BLANK

Project # 612097		Contract # 129070		
Location : CHICOPEE - WEST SPRINGFIELD				
Description : Pavement and Bridge Preservation on I-91				
ITEM #	QUANTITY	ITEM WITH UNIT BID PRICE WRITTEN IN WORDS	UNIT PRICE	AMOUNT
101.1	0.5	CLEARING AT _____ PER ACRE		
102.1	6,000	TREE TRIMMING AT _____ PER FOOT		
106.15	1	BLEEDER (BRIDGE DECK) PVC AT _____ EACH		
106.151	1	PVC DRAIN PIPE EXTENSIONS AT _____ EACH		
120.	220	EARTH EXCAVATION AT _____ PER CUBIC YARD		
127.1	15	REINFORCED CONCRETE EXCAVATION AT _____ PER CUBIC YARD		
127.4	475	REINFORCED CONCRETE DECK EXCAVATION (FULL DEPTH) AT _____ PER SQUARE YARD		
127.41	70	REINFORCED CONCRETE DECK EXCAVATION (PARTIAL DEPTH) AT _____ PER CUBIC YARD		
129.6	2,895	BRIDGE PAVEMENT EXCAVATION AT _____ PER SQUARE YARD		

Project # 612097 Contract # 129070

Location : CHICOPEE - WEST SPRINGFIELD

Description : Pavement and Bridge Preservation on I-91

ITEM #	QUANTITY	ITEM WITH UNIT BID PRICE WRITTEN IN WORDS	UNIT PRICE	AMOUNT
141.	15	CLASS A TRENCH EXCAVATION AT _____ PER CUBIC YARD		
141.1	5	TEST PIT FOR EXPLORATION AT _____ PER CUBIC YARD		
150.	5	ORDINARY BORROW AT _____ PER CUBIC YARD		
151.	70	GRAVEL BORROW AT _____ PER CUBIC YARD		
170.	265	FINE GRADING AND COMPACTING - SUBGRADE AREA AT _____ PER SQUARE YARD		
180.01	1	ENVIRONMENTAL HEALTH AND SAFETY PROGRAM AT _____ LUMP SUM		
180.02	8	PERSONAL PROTECTION LEVEL C UPGRADE AT _____ PER HOUR		
180.03	40	LICENSED SITE PROFESSIONAL SERVICES AT _____ PER HOUR		
181.11	204	DISPOSAL OF UNREGULATED SOIL AT _____ PER TON		

Project # 612097		Contract # 129070		
Location : CHICOPEE - WEST SPRINGFIELD				
Description : Pavement and Bridge Preservation on I-91				
ITEM #	QUANTITY	ITEM WITH UNIT BID PRICE WRITTEN IN WORDS	UNIT PRICE	AMOUNT
181.12	26	DISPOSAL OF REGULATED SOIL - IN-STATE FACILITY AT _____ PER TON		
181.13	26	DISPOSAL OF REGULATED SOIL - OUT-OF-STATE FACILITY AT _____ PER TON		
181.14	1	DISPOSAL OF HAZARDOUS WASTE AT _____ PER TON		
184.1	0.5	DISPOSAL OF TREATED WOOD PRODUCTS AT _____ PER TON		
220.	81	DRAINAGE STRUCTURE ADJUSTED AT _____ EACH		
220.2	105	DRAINAGE STRUCTURE REBUILT AT _____ PER FOOT		
221.1	1	FRAME AND COVER - SECURED AT _____ EACH		
222.	1	FRAME AND GRATE - MASSDOT BAR TYPE AT _____ EACH		
223.2	2	FRAME AND GRATE (OR COVER) REMOVED AND DISCARDED AT _____ EACH		

Project # 612097 Contract # 129070

Location : CHICOPEE - WEST SPRINGFIELD

Description : Pavement and Bridge Preservation on I-91

ITEM #	QUANTITY	ITEM WITH UNIT BID PRICE WRITTEN IN WORDS	UNIT PRICE	AMOUNT
227.3	105	REMOVAL OF DRAINAGE STRUCTURE SEDIMENT AT _____ PER CUBIC YARD		
227.31	500	REMOVAL OF DRAINAGE PIPE SEDIMENT AT _____ PER FOOT		
280.	30	HOT MIX ASPHALT WATERWAY AT _____ PER SQUARE YARD		
280.2	505	CLEANING PAVED WATERWAYS AT _____ PER SQUARE YARD		
402.14	60	PAVEMENT MILLING MULCH FOR SHOULDERS AT _____ PER TON		
415.2	130,940	PAVEMENT FINE MILLING AT _____ PER SQUARE YARD		
415.4	14,445	BRIDGE PAVEMENT MILLING AT _____ PER SQUARE YARD		
450.231	3,480	SUPERPAVE SURFACE COURSE - 12.5 POLYMER (SSC - 12.5 - P) AT _____ PER TON		
451.	235	HMA FOR PATCHING AT _____ PER TON		

Project # 612097 Contract # 129070

Location : CHICOPEE - WEST SPRINGFIELD

Description : Pavement and Bridge Preservation on I-91

ITEM #	QUANTITY	ITEM WITH UNIT BID PRICE WRITTEN IN WORDS	UNIT PRICE	AMOUNT
452.	13,320	ASPHALT EMULSION FOR TACK COAT AT _____ PER GALLON		
453.	82,365	HMA JOINT ADHESIVE AT _____ PER FOOT		
457.2	2,270	SUPERPAVE WATERPROOFING SURFACE COURSE - 12.5 (SSC-W-12.5) AT _____ PER TON		
458.2	8,310	SUPERPAVE HIGH PERFORMANCE SURFACE COURSE (HP-12.5) AT _____ PER TON		
470.	40	HOT MIX ASPHALT BERM AT _____ PER TON		
472.	100	TEMPORARY ASPHALT PATCHING AT _____ PER TON		
477.	31,500	MILLED RUMBLE STRIP (TYPE A) AT _____ PER FOOT		
482.31	685	SAWING AND SEALING JOINTS IN ASPHALT PAVEMENT AT BRIDGES AT _____ PER FOOT		
504.	10	GRANITE CURB TYPE VA4 - STRAIGHT AT _____ PER FOOT		

Project # 612097		Contract # 129070		
Location : CHICOPEE - WEST SPRINGFIELD				
Description : Pavement and Bridge Preservation on I-91				
ITEM #	QUANTITY	ITEM WITH UNIT BID PRICE WRITTEN IN WORDS	UNIT PRICE	AMOUNT
504.2	4	GRANITE CURB TYPE VA4 - SPLAYED END AT _____ EACH		
509.	35	GRANITE TRANSITION CURB FOR PEDESTRIAN CURB RAMPS - STRAIGHT AT _____ PER FOOT		
511.1	10	GRANITE EDGING TYPE SB - STRAIGHT AT _____ PER FOOT		
580.	20	CURB REMOVED AND RESET AT _____ PER FOOT		
583.	50	EDGING REMOVED AND RESET AT _____ PER FOOT		
594.	10	CURB REMOVED AND DISCARDED AT _____ PER FOOT		
597.	65	EDGING REMOVED AND DISCARDED AT _____ PER FOOT		
620.13	240	GUARDRAIL, TL-3 (SINGLE FACED) AT _____ PER FOOT		
626.321	1	MAINTENANCE OF STEEL THRIE BEAM BRIDGE RAIL RETROFIT AT _____ LUMP SUM		

Project # 612097 Contract # 129070

Location : CHICOPEE - WEST SPRINGFIELD

Description : Pavement and Bridge Preservation on I-91

ITEM #	QUANTITY	ITEM WITH UNIT BID PRICE WRITTEN IN WORDS	UNIT PRICE	AMOUNT
626.322	10	BRIDGE RAIL RETROFIT BLOCK OUT REPLACEMENT AT _____ EACH		
627.1	3	TRAILING ANCHORAGE AT _____ EACH		
627.83	1	GUARDRAIL TANGENT END TREATMENT, TL-3 AT _____ EACH		
628.21	3	TRANSITION TO NCHRP 350 GUARDRAIL AT _____ EACH		
628.25	1	TRANSITION TO THRIE BEAM AT _____ EACH		
630.2	825	HIGHWAY GUARD REMOVED AND DISCARDED AT _____ PER FOOT		
632.	30	GUARDRAIL POST - STEEL AT _____ EACH		
633.	30	GUARDRAIL OFFSET BLOCK - W BEAM AT _____ EACH		
633.1	8	GUARDRAIL OFFSET BLOCK - THRIE BEAM AT _____ EACH		

Project # 612097		Contract # 129070		
Location : CHICOPEE - WEST SPRINGFIELD				
Description : Pavement and Bridge Preservation on I-91				
ITEM #	QUANTITY	ITEM WITH UNIT BID PRICE WRITTEN IN WORDS	UNIT PRICE	AMOUNT
634.	30	W BEAM GUARD PANEL AT _____ EACH		
634.1	4	THRIE BEAM GUARD PANEL AT _____ EACH		
701.2	4	CEMENT CONCRETE PEDESTRIAN CURB RAMP AT _____ PER SQUARE YARD		
722.3	1	SCHEDULE OF OPERATIONS (TYPE C) - FIXED PRICE \$60,000 AT Sixty Thousand Dollars LUMP SUM	\$60,000.00	\$60,000.00
740.	20	ENGINEER'S FIELD OFFICE AND EQUIPMENT (TYPE A) AT _____ PER MONTH		
748.	1	MOBILIZATION AT _____ LUMP SUM		
748.11	5	MOBILIZATION FOR EMERGENCY REPAIRS AT _____ EACH		
751.	45	LOAM FOR ROADSIDES AT _____ PER CUBIC YARD		
765.	425	SEEDING AT _____ PER SQUARE YARD		

Project # 612097 Contract # 129070

Location : CHICOPEE - WEST SPRINGFIELD

Description : Pavement and Bridge Preservation on I-91

ITEM #	QUANTITY	ITEM WITH UNIT BID PRICE WRITTEN IN WORDS	UNIT PRICE	AMOUNT
767.121	1,500	SEDIMENT CONTROL BARRIER AT _____ PER FOOT		
769.	825	PAVEMENT MILLING MULCH UNDER GUARD RAIL AT _____ PER FOOT		
819.907	2	INSTALL 3 LANE CLASSIFICATION TRAFFIC DATA STATION AT _____ EACH		
832.	25	WARNING-REGULATORY AND ROUTE MARKER - ALUMINUM PANEL (TYPE A) AT _____ PER SQUARE FOOT		
833.5	70	DEMOUNTABLE REFLECTORIZED DELINEATOR - GUARD RAIL AT _____ EACH		
833.7	25	DELINEATION FOR GUARD RAIL TERMINI AT _____ EACH		
834.	5	DEMOUNTABLE REFLECTORIZED REFERENCE LOCATION SIGN AT _____ EACH		
836.5	10	DEMOUNTABLE REFLECTORIZED STATION MARKER AT _____ EACH		
847.1	2	SIGN SUP (N/GUIDE)+RTE MKR W/1 BRKWAY POST ASSEMBLY - STEEL AT _____ EACH		

Project # 612097 Contract # 129070

Location : CHICOPEE - WEST SPRINGFIELD

Description : Pavement and Bridge Preservation on I-91

ITEM #	QUANTITY	ITEM WITH UNIT BID PRICE WRITTEN IN WORDS	UNIT PRICE	AMOUNT
848.1	2	SIGN SUP (N/GUIDE)+RTE MKR W/2 BRKWAY POST ASSEMBLIES-STEEL AT _____ EACH		
851.1	260	TRAFFIC CONES FOR TRAFFIC MANAGEMENT AT _____ PER DAY		
852.	1,145	SAFETY SIGNING FOR TRAFFIC MANAGEMENT AT _____ PER SQUARE FOOT		
853.403	390	TRUCK MOUNTED ATTENUATOR AT _____ PER DAY		
853.8	260	TEMPORARY ILLUMINATION FOR WORK ZONE AT _____ PER DAY		
854.016	81,370	TEMPORARY PAVING MARKINGS - 6 INCH (PAINTED) AT _____ PER FOOT		
854.036	4,900	TEMPORARY PAVING MARKINGS - 6 INCH (TAPE) AT _____ PER FOOT		
854.6	390	TEMPORARY PORTABLE RUMBLE STRIP AT _____ PER DAY		
856.	390	ARROW BOARD AT _____ PER DAY		

Project # 612097 Contract # 129070

Location : CHICOPEE - WEST SPRINGFIELD

Description : Pavement and Bridge Preservation on I-91

ITEM #	QUANTITY	ITEM WITH UNIT BID PRICE WRITTEN IN WORDS	UNIT PRICE	AMOUNT
856.11	390	PORTABLE SPEED FEEDBACK SIGN AT _____ PER DAY		
856.12	390	PORTABLE CHANGEABLE MESSAGE SIGN AT _____ PER DAY		
859.	3,900	REFLECTORIZED DRUM AT _____ PER DAY		
859.1	390	REFLECTORIZED DRUMS WITH SEQUENTIAL FLASHING WARNING LIGHTS AT _____ PER DAY		
862.506	45,175	FAST DRY MULTI-COMPONENT PAVEMENT MARKINGS, RECESSED, WET REFLECTIVE (6 INCH WHITE LINE) AT _____ PER FOOT		
862.512	2,225	FAST DRY MULTI-COMPONENT PAVEMENT MARKINGS, RECESSED, WET REFLECTIVE (12 INCH WHITE LINE) AT _____ PER FOOT		
862.524	615	FAST DRY MULTI-COMPONENT PAVEMENT MARKINGS, RECESSED, WET REFLECTIVE (24 INCH WHITE LINE) AT _____ PER FOOT		
863.506	33,970	FAST DRY MULTI-COMPONENT PAVEMENT MARKINGS, RECESSED, WET REFLECTIVE (6 INCH YELLOW LINE) AT _____ PER FOOT		
864.04	465	PAVEMENT ARROWS AND LEGENDS REFLECTORIZED WHITE (THERMOPLASTIC) AT _____ PER SQUARE FOOT		

Project # 612097 Contract # 129070

Location : CHICOPEE - WEST SPRINGFIELD

Description : Pavement and Bridge Preservation on I-91

ITEM #	QUANTITY	ITEM WITH UNIT BID PRICE WRITTEN IN WORDS	UNIT PRICE	AMOUNT
864.31	365	SLOTTED PAVEMENT MARKER ONE-WAY WHITE AT _____ EACH		
864.33	530	SLOTTED PAVEMENT MARKER TWO-WAY WHITE/RED AT _____ EACH		
864.34	295	SLOTTED PAVEMENT MARKER TWO-WAY YELLOW/RED AT _____ EACH		
874.41	2	TRAFFIC SIGN REMOVED AND DISCARDED AT _____ EACH		
905.	1	4000 PSI, 3/8 INCH, 660 CEMENT CONCRETE AT _____ PER CUBIC YARD		
909.3	180	RAPID SETTING LOW PERMEABILITY CONCRETE AT _____ PER CUBIC YARD		
910.1	200	STEEL REINFORCEMENT FOR STRUCTURES - EPOXY COATED AT _____ PER POUND		
912.	50	DRILLING AND GROUTING DOWELS AT _____ EACH		
973.1	410	PRE-COMPRESSED JOINT SEAL WITH POLYURETHANE RESIN CONCRETE HEADERS AT _____ PER FOOT		

Project # 612097		Contract # 129070		
Location : CHICOPEE - WEST SPRINGFIELD				
Description : Pavement and Bridge Preservation on I-91				
ITEM #	QUANTITY	ITEM WITH UNIT BID PRICE WRITTEN IN WORDS	UNIT PRICE	AMOUNT
973.2	555	PRE-COMPRESSED JOINT SEAL AT _____ PER FOOT		
994.1	4,770	TEMPORARY PROTECTIVE SHIELDING AT _____ PER SQUARE FOOT		
Total Qty:		487,764		

THIS PAGE IS INTENTIONALLY LEFT BLANK

DOCUMENT B00853

SCHEDULE OF PARTICIPATION BY DISADVANTAGED BUSINESS ENTERPRISES (DBES)

PRIME BIDDER: _____

DATE OF BID OPENING: _____ PROJECT NO.: 612097

FEDERAL AID PROJECT NO. NHP(IM)/HIP(BR)-0912(310)X

PROJECT LOCATION: WEST SPRINGFIELD - CHICOPEE

Name, Address, and Phone Number(s) of DBE	Name of Activity	(a)† DBE Contractor Activity Amount <i>Construction Work</i>	(b) DBE Other Business Amount <i>Services, Supplies, Material</i>	(c) Total amount eligible for credit under rules in Section 6 of Document 00719 - DBE Special Provisions
Total Bid Amount	TOTALS:	\$	\$	\$
\$	DBE Percentage of Total Bid:	%	%	%

†Column (a) must be at least one-half of the DBE participation goal. Attach additional sheets as necessary.

Is MassDOT Document B00855 (Joint Check Approval) being submitted for any of the above? Yes No

Not Known at This Time

Will any of the contractors listed above be using a third party (i.e. manufacturer) to deliver materials or perform any portion of work by a third party? Yes No

CERTIFICATION: I HEREBY DECLARE, TO THE BEST OF MY KNOWLEDGE, THAT I HAVE READ THE SPECIAL PROVISIONS FOR PARTICIPATION BY DISADVANTAGED BUSINESS ENTERPRISES - DOCUMENT 00719. BOTH THIS SCHEDULE AND THE RELEVANT AND ACCOMPANYING LETTER(S) OF INTENT ARE IN FULL COMPLIANCE WITH THE PROVISIONS OF, AND IN ACCORDANCE WITH, TITLE 49 CODE OF FEDERAL REGULATIONS, PART 26 (49 CFR Part 26).

SIGNATURE: _____ DATE _____

NAME AND TITLE (PRINT): _____

EMAIL ADDRESS: _____ TEL NO.: _____

*** END OF DOCUMENT ***

THIS PAGE INTENTIONALLY LEFT BLANK



DOCUMENT B00854

DISADVANTAGED BUSINESS ENTERPRISES (DBE) PARTICIPATION LETTER OF INTENT

(To be completed by the DBE – Page 1 of 2)

TO: _____ (Prime Bidder)

FROM: _____ (DBE Firm)

RE: PROJECT NO.: 612097 FEDERAL AID PROJECT NO.: NHP(IM)/HIP(BR)-0912(310)X

PROJECT LOCATION: WEST SPRINGFIELD - CHICOPEE

DATE OF BID OPENING: _____

I, _____, authorized signatory of the above-referenced DBE firm hereby declare:
Print Name

1. My company is currently certified as a Disadvantaged Business Enterprise (DBE) by the Massachusetts Supplier Diversity Office ("SDO"), formerly known as the State Office of Minority and Women Business Assistance (SOMWBA), as a: (check all applicable, see Section 1 of the Special Provisions For Participation By Disadvantaged Business Enterprises, MassDOT Document 00719 additional guidance is available at Title 49, Code of Federal Regulations, Part 26.55 (49 CFR Part 26.55)):

- () CONTRACTOR () REGULAR DEALER () BROKER
() MANUFACTURER () TRUCKING OPERATIONS () PROFESSIONAL SERVICES

2. My firm has the ability to manage, supervise and perform the activity described on page 2 of this Letter of Intent. If you are awarded the contract, my company intends to enter into a contract with your firm to perform the items of work or other activity described on the following sheet for the prices indicated.

3. There have been no changes affecting the ownership, control or independence of my company since my last certification review on _____, 20___. If any such change is planned or occurs prior to my company's completion of this proposed work, I will give prior written notification to your firm and to the Massachusetts Department of Transportation ("MassDOT") Office of Civil Rights and SDO.

4. I have read the MassDOT proposal for the Project which may be entitled "Project Contract Documents and Special Provisions" or the draft "Contract" which includes MassDOT Document 00719, and acknowledge that my company will comply with that document and the requirements of 49 CFR Part 26.

5. For the purpose of obtaining subcontractor approval from MassDOT, my firm will provide to you:

A. The following construction work:

- (i) a resume, stating the qualifications and experience, of the superintendent or foreperson who will supervise on site-work;
(ii) a list of equipment owned or leased by my firm for use on this project; and
(iii) a list of all projects (public or private) upon which my firm is currently performing, is committed to perform, or intends to make a commitment to perform. I shall also include, for each project: the name and telephone number of a contact person for the contracting authority, person, or organization; the dollar value of the work; a description of the work; and my firm's work schedule for the project.

B. The following services, materials or supplies:

- (i) a written agreement and invoices for the materials or supplies, and any other documents evidencing the terms of providing such items;
(ii) information concerning brokers fees and commissions for providing services or materials; and
(iii) a statement concerning whether my firm intends or will be required to use a joint check arrangement; and any other documents that may be required by MassDOT.

DBE Company Authorized Signature _____ Date _____

DISADVANTAGED BUSINESS ENTERPRISES (DBE) PARTICIPATION
LETTER OF INTENT
(To be completed by the DBE – Page 2 of 2)

DATE OF BID OPENING: _____

PROJECT NUMBER: 612097

FEDERAL AID PROJECT NUMBER: XXX

PROJECT LOCATION: WEST SPRINGFIELD - CHICOPEE

PRIME BIDDER: _____

DBE COMPANY NAME: _____

<u>Item number</u> if applicable	<u>NAICS</u> <u>Code</u>	<u>Description of Activity</u> with notations such as Services, or Brokerage, Installation Only, Material Only, or Complete	<u>Quantity</u>	<u>Unit Price</u>	<u>Amount</u>
				TOTAL AMOUNT:	

Please give full explanations, attach additional sheets if necessary.

I HEREBY VERIFY THAT _____ WILL SOLELY
(DBE company name)
PERFORM THE WORK, OR PROVIDE THE SERVICES OR MATERIALS, AS DESCRIBED ABOVE.

DBE AUTHORIZED SIGNATURE: _____

NAME AND TITLE (PRINT): _____

TELEPHONE NUMBER: _____ FAX NUMBER: _____

EMAIL ADDRESS: _____

*** END OF DOCUMENT ***

Rev'd 9/20/19

DOCUMENT B00855

DBE JOINT CHECK ARRANGEMENT APPROVAL FORM

(to be submitted by Prime Contractor)

Contract No: 129070 Project No. 612097 Federal Aid No.: NHP(IM)/HIP(BR)-0912(310)X

Location: WEST SPRINGFIELD - CHICOPEE Bid Opening Date:

Project Description: Pavement and Bridge Preservation on I-91

We have received the attached request for the use of a joint check arrangement from _____, a DBE on the above- referenced Contract and _____, a Material Supplier/Vendor for the subject Contract. The DBE has complied with the requirements of 49 CFR Part 26.55(c)(1). In particular, the DBE has:

- a written agreement with the material supplier/vendor;
• applied for credit with the subject material supplier and has supplied the vendor's response;
• shown that it will place all orders to the subject material supplier/vendor;
• made and retains all decision-making responsibilities concerning the materials; and
• provided a Joint Check Agreement that is acceptable to MassDOT;

As the Contractor for the Project, we agree to issue joint checks (made payable to the Material Supplier/Vendor and the DBE) for payment of sums due pursuant to invoices from the Supplier/Vendor and DBE.

Contractor:

Company Name Signature Duly Authorized
Printed Name
Date Title

SubContractor:

Company Name Signature - Duly Authorized
Printed Name
Date Title

*** END OF DOCUMENT ***

THIS PAGE INTENTIONALLY LEFT BLANK

DOCUMENT B00856

JOINT VENTURE AFFIDAVIT
(All Firms)

- All Information Requested By This Schedule Must Be Answered. Additional Sheets May Be Attached.
- If, there is any change in the information submitted, the Joint Venture parties must inform MassDOT Pre-Qualifications Office (and, if one of the companies is a DBE, the Director of Contract Compliance, Office of Civil Rights) *prior* to such change, in writing, either directly or through the Prime Contractor if the Joint Venture is a subcontractor.
- If the Joint Venture Entity will be the bidder on a prime Contract, it must bid and submit all required documents (insurance, worker’s compensation, bonds, etc.) in the name of the Joint Venture Entity.

I. Name of Joint Venture: _____

Type of Entity if applicable (Corp., LLC): _____ Filing State _____

Address of joint venture: _____

Phone No(s) for JV Entity: _____ E-mail: _____

Contact Person(s) _____

Tax ID/EIN of Joint Venture: _____ Vendor Code: _____

II. Identify each firm or party to the Joint Venture:

Name of Firm: _____

Address: _____

Phone : _____ E-mail: _____

Contact person(s) _____

Name of Firm: _____

Address: _____

Phone: _____ E-mail: _____

Contact Person(s) _____

III. Describe the role(s) of the each party to the Joint Venture:

IV. Attach a copy of the Joint Venture Agreement. The proposed Joint Venture Agreement should include specific details including, but not limited to: (1) the contributions of capital and equipment; (2) work items to be performed by each company’s forces, (3) work items to be performed under the supervision of any DBE Venturer; (4) the commitment of management, supervisory and operative personnel employed by the DBE to be dedicated to the performance of the Project; and (5) warranty, guaranty, and indemnification clauses.

V. Attach any applicable Corporate or LLC Votes, Authorizations, etc.

VI. Ownership of the Joint Venture:

A. What is the percentage(s) of each company’s ownership in the Joint Venture?

ownership percentage(s): _____

ownership percentage(s): _____

B. Specify percentages for each of the following (provide narrative descriptions and other detail as applicable):

1. Sharing of profit and loss: _____

2. Capital contributions:

(a) Dollar amounts of initial contribution: _____

(b) Dollar amounts of anticipated on-going contributions: _____

(c) Contributions of equipment (specify types, quality and quantities of equipment to be provided by each firm): _____

4. Other applicable ownership interests, including ownership options or other agreements, which restrict or limit ownership and/or control:

5. Provide copies of all other written agreements between firms concerning bidding and operation of this Project or projects or contracts.

6. Identify all current contracts and contracts completed during the past two (2) years by either of the Joint Venture partners to this Joint Venture:

VII. Control of and Participation in the Joint Venture. Identify by name and firm those individuals who are, or will be, responsible for and have the authority to engage in the following management functions and policy decisions. (Indicate any limitations to their authority such as dollar limits and co-signatory requirements.):

A. Joint Venture check signing:

B. Authority to enter Contracts on behalf of the Joint Venture:

C. Signing, co-signing and/or collateralizing loans:

D. Acquisition of lines of credit:

E. Acquisition and indemnification of payment and performance bonds:

F. Negotiating and signing labor agreements:

G. Management of contract performance. *(Identify by name and firm only):*

1. Supervision of field operations: _____
2. Major purchases: _____
3. Estimating: _____
4. Engineering: _____

VIII. Financial Controls of Joint Venture:

A. Which firm and/or individual will be responsible for keeping the books of account?

B. Identify the "Managing Partner," if any, and describe the means and measure of their compensation:

C. What authority does each firm have to commit or obligate the other to insurance and bonding companies, financing institutions, suppliers, subcontractors, and/or other parties participating in the performance of this Contract or the work of this Project?

IX. Personnel of Joint Venture: State the approximate number of personnel (by trade) needed to perform the Joint Venture's work under this Contract. Indicate whether they will be employees of the majority firm, DBE firm, or the Joint Venture.

	Firm 1 (number)	Firm 2 (number)	Joint Venture (number)
Trade			
Professional			
Administrative/Clerical			
Unskilled Labor			

Will any personnel proposed for this Project be employees of the Joint Venture?: _____

If so, who: _____

A. Are any proposed Joint Venture employees currently employed by either firm?

Employed by Firm 1: _____ Employed by firm 2 _____

B. Identify by name and firm the individual who will be responsible for Joint Venture hiring: _____

X. Additional Information. Please state any material facts and additional information pertinent to the control and structure of this Joint Venture.

XI. AFFIDAVIT OF JOINT VENTURE PARTIES. The undersigned affirm that the foregoing statements and attached documents are correct and include all material information necessary to identify and explain the terms and operations of our Joint Venture and the intended participation of each firm in the undertaking. Further, the undersigned covenant and agree to provide to MassDOT current, complete and accurate information regarding actual Joint Venture work, payments, and any proposed changes to any provisions of the Joint Venture, or the nature, character of each party to the Joint Venture. We understand that any material misrepresentation will be grounds for terminating any Contract awarded and for initiating action under Federal or State laws concerning false statements.

Firm 1

Firm 2

Signature
Duly Authorized

Signature
Duly Authorized

Printed Name and Title

Printed Name and Title

Date

Date

*** END OF DOCUMENT ***